

CROSS SECTION
(25' SPAN)

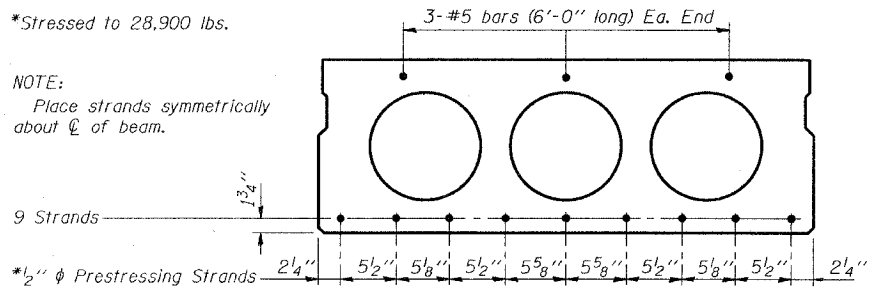

CROSS SECTION
(30' SPAN)

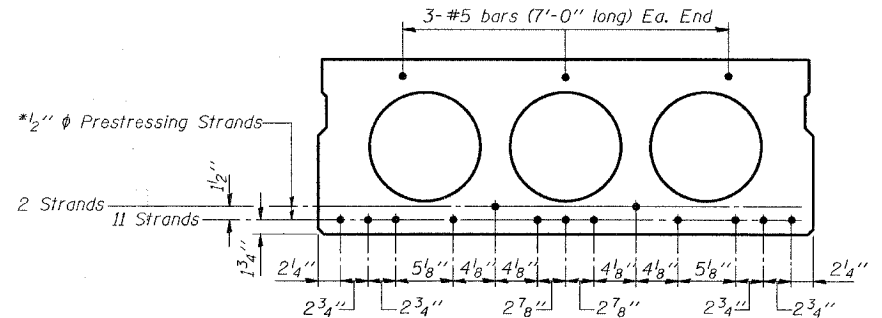

CROSS SECTION
(35' SPAN)

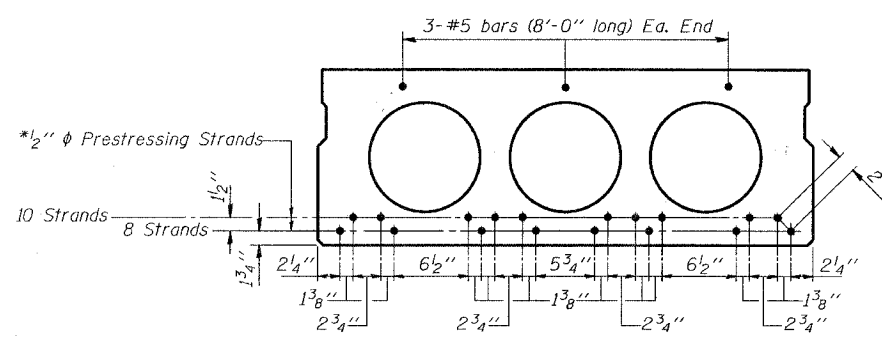

CROSS SECTION
(40' SPAN)

Illinois Department of Transportation
 PASSED NOVEMBER 1, 1995
 Approved by: *Gregory J. Kasper*
 Engineer of Bridge Design
 APPROVED NOVEMBER 1, 1995
 Approved by: *Walsh E. Anderson*
 Engineer of Bridges and Structures

NOTE
 The std. reinf. shown on the 25' span cross section is typical for all spans, except as shown.

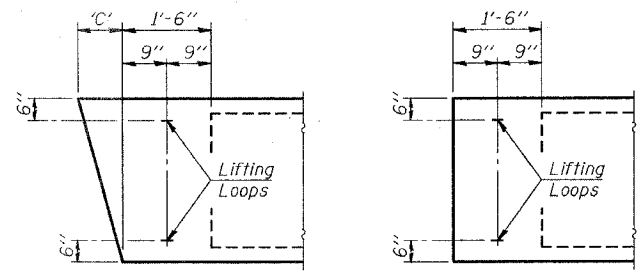

END BLOCK DETAILS

Each beam shall have four Lifting Loops, two at each end of beam cast in locations shown above. Loops shall be burned off after beams have been erected.

DIMENSION 'C'

Skew Angle 'D'	0°	5°	10°	15°	20°	25°	30°
Dimension 'C' (Inches)	0	4 1/4	8 1/2	12 7/8	17 1/2	22 3/8	27 3/4

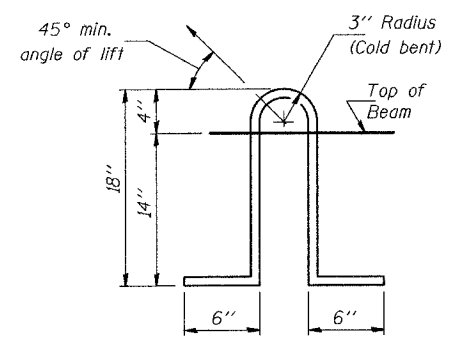

LIFTING LOOP DETAIL

Lifting loops shall be 2. 1/2 inch diameter 270 ksi strands, as shown. Alternate approved lifting devices are also acceptable.

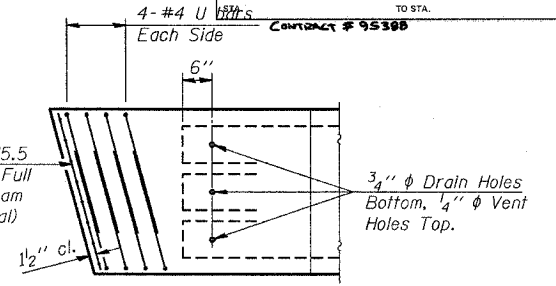

END REINFORCEMENT
(SKEWED)

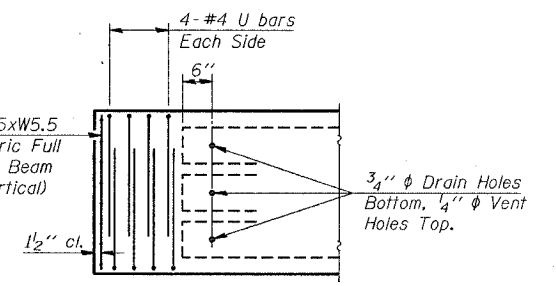

END REINFORCEMENT
(RIGHT ANGLE)

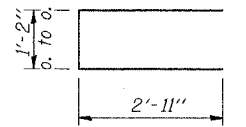

BAR U

NOTES

- Prestressing steel shall be uncoated high strength, stress relieved 7-wire strand, Grade 270.
- The nominal diameter shall be 1/2 inch and the nominal cross-sectional area shall be 0.153 square inches.
- Reinforcement bars shall conform to AASHTO M-31, M-42 or M-53, Grade 60.
- Rail Post anchor devices shall be cast into outside beam as elsewhere specified.
- When Waterproofing Membrane System is specified, the top surface of the beams shall be finished in accordance with Article 504.06 of the Standard Specifications except that the surface shall not be roughened by brooming. The finished surface shall be free of depressions or high spots with sharp corners, and the top edge of keys shall be rounded or chamfered a minimum of 1/4 inch.
- Low-relaxation strands may be substituted for the stress relieved strands. The initial prestressing force applied to each strand shall be the same as for the stress relieved strands (28,900 lbs.).
- Keyway surfaces shall be cleaned to remove form oil or other bond breaking material prior to shipment of the beams. Cleaning shall be done by sandblasting the keyway areas between the top of the beam and the bottom edge of the key.

DESIGN STRESSES

$f'_c = 5,000$ p.s.i.
 f'_{ci} = (See Required Release Strength Table)
 $f'_s = 270,000$ p.s.i. (1/2 inch diameter Strand)
 $f_{si} = 189,000$ p.s.i. (1/2 inch diameter Strand)
 $f_y = 60,000$ p.s.i.

REQUIRED RELEASE STRENGTH

Span	f'_{ci} (psi)
25'	4,000
30'	4,000
35'	4,200
40'	4,700

P.P.C. DECK BEAM DETAILS
 24' ROADWAY | 17" x 48" BEAMS
 STANDARD CB-2417-48