

ELEVATION

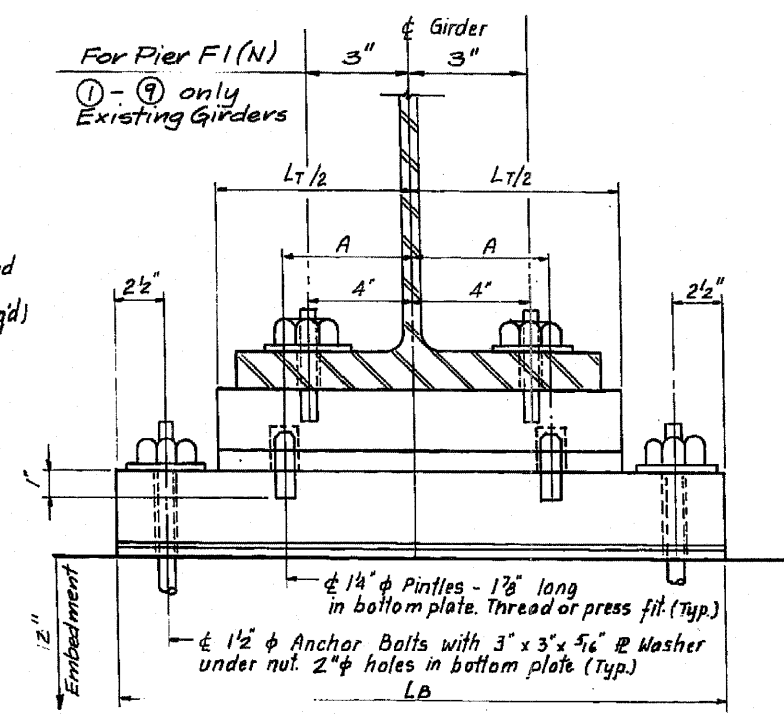

SECTION A-A

FIXED BEARING SCHEDULE - TYPE F1

STRUCTURE NO.	PIER LOCATION	GIRDER NO.	BRG TYPE	NO. REQ'D	T _T "	L _T "	T _B "	L _B "	A"	H"
016-1050	74 (N)	GG 21	F1	1	2 1/2	17	2	27	4 1/2	4 5/8

* H - height does not include Shim PL.

FIXED BEARING - TYPE F1
 f = Surface finish shall have ANSI surface roughness value not exceeding 250.

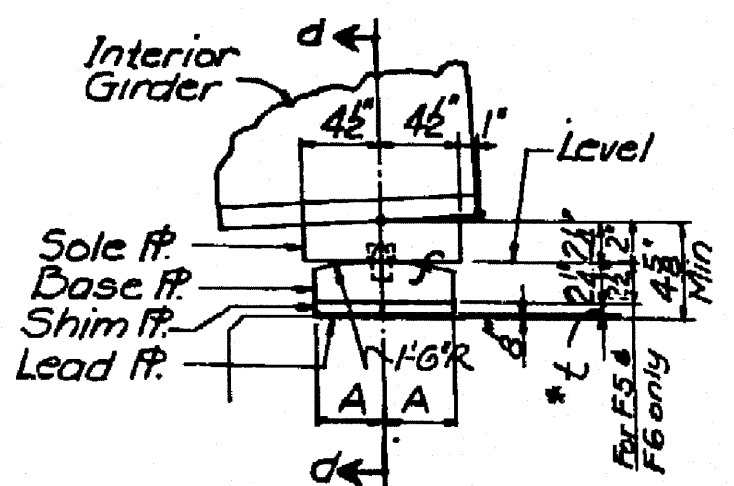

* Shim plate if required for t see schedule
 f = Finish

SECTION C-C

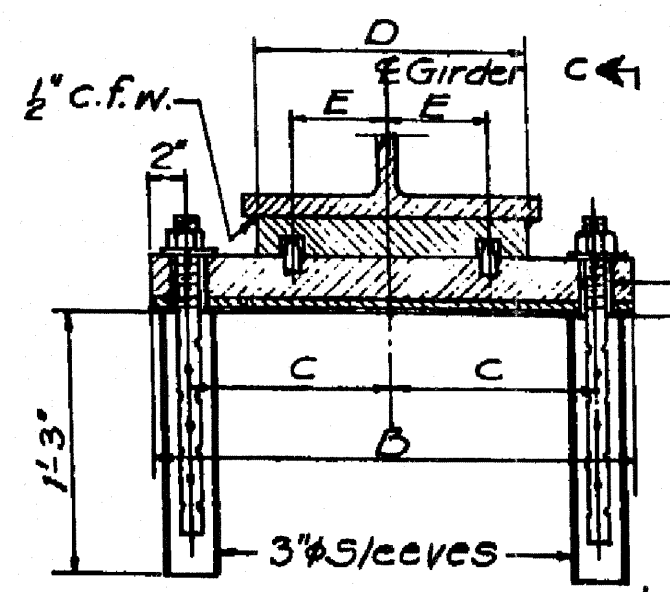

SECTION D-D

(1 1/2" Holes for 1 1/2" x 1-8" Swedge Anch. Bolts, Hex. Nuts & 2 1/2" x 2 1/2" x 5/16" Plate Washers.)

FIXED BEARING SCHEDULE						
MARK	DIMENSIONS					REMARKS
	A	B	C	D	E	
F	4"	2'-3"	1 1/2"	1'-3"	5 1/2"	Typical for 16" flange

FIXED BEARING DETAILS