

RAMPS A, B, & C
EXISTING TYPICAL SECTION

- LEGEND
- ① EXISTING SUBBASE GRANULAR MATERIAL, TYPE A, 6"
 - ② EXISTING PCC PAVEMENT, 9"±
 - ③ EXISTING COMBINATION CONCRETE CURB AND GUTTER
 - ④ EXISTING PCC MEDIAN
 - ⑤ EXISTING CORRUGATED MEDIAN
 - ⑥ EXISTING STABILIZED SUBBASE, 4"
 - ⑦ EXISTING TOP SOIL AND SODDING
 - ⑧ PROPOSED MEDIAN REMOVAL, PARTIAL DEPTH
 - ⑨ PROPOSED PCC SURFACE REMOVAL, VARIABLE DEPTH
 - ⑩ PROPOSED HMA SURFACE COURSE, MIX "D", N70, 1-1/2"
 - ⑪ PROPOSED POLYMERIZED LEVELING BINDER (MACHINE METHOD), IL-4.75, N50, 1"
 - ⑫ PROPOSED PARTIAL DEPTH REMOVAL, 3"
 - ⑬ PROPOSED HMA BINDER COURSE, IL-19.0, N70, 3"
(NOTE: SEE DETAIL ON SHEET #5)

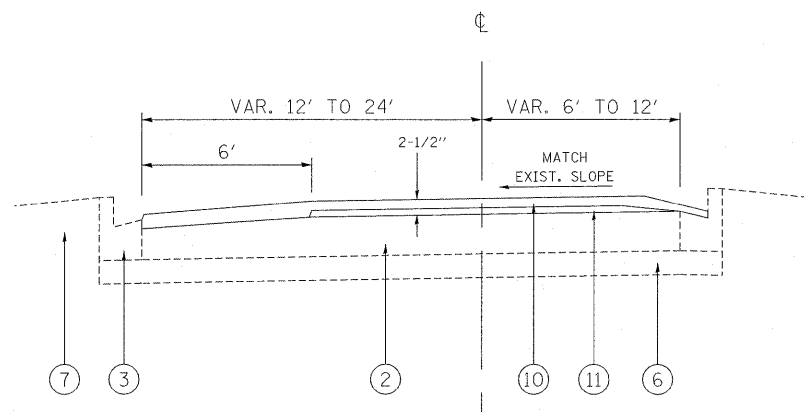

RAMPS A, B, & C
PROPOSED TYPICAL SECTION

FILE NAME =	USER NAME = tarisqfm	DESIGNED -	REVISED -	STATE OF ILLINOIS DEPARTMENT OF TRANSPORTATION	IL 171 - 1st AVE. FRONTAGE ROAD (JOLIET RD. TO 47TH ST.) EXISTING AND PROPOSED TYPICAL SECTIONS	F.A.P. RTE.	SECTION	COUNTY	TOTAL SHEETS	SHEET NO.	
ct\pw_work\pwidot\tarisqfm\251775\0132	11-shr-plan.dgn	DRAWN -	REVISED -			372	2010-155-RS	COOK	27	7	
PLOT SCALE = 50.0000' / IN.	CHECKED -	REVISED -	REVISED -			CONTRACT NO. 60N59					
PLOT DATE = 4/7/2011	DATE -	REVISED -	REVISED -			ILLINOIS FED. AID PROJECT					
					SCALE:	SHEET NO.	OF	SHEETS	STA.	TO STA.	