

EXISTING TYPICAL SECTION  
ILL 171  
STA. 264+00 TO STA. 376+74.48

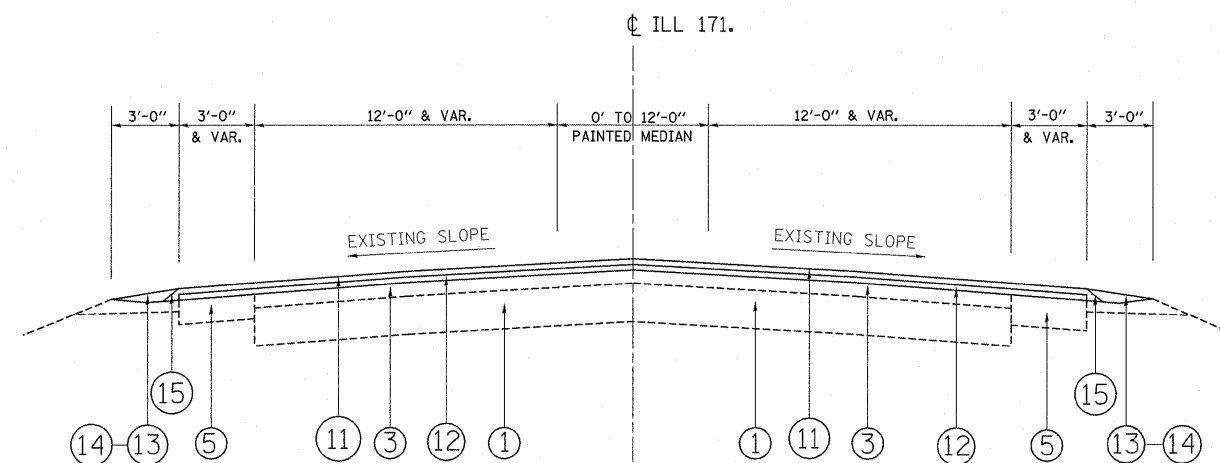

PROPOSED TYPICAL SECTION  
ILL 171  
STA. 264+00 TO STA. 376+74.48

**LEGEND**

- ① EXISTING P.C.C. PAVEMENT, ±10"
- ② EXISTING P.C.C. PAVEMENT, ±9"
- ③ EXISTING HOT-MIX ASPHALT AFTER MILLING, ±5/4"
- ④ EXISTING HOT-MIX ASPHALT AFTER MILLING, ±3/4" \*
- ⑤ EXISTING HOT-MIX ASPHALT SHOULDER
- ⑥ EXISTING AGGREGATE SHOULDER
- ⑦ EXISTING COMBINATION CONCRETE CURB & GUTTER, TYPE B-6.12 & B-6.24
- ⑧ EXISTING MEDIAN
- ⑨ PROPOSED HOT-MIX ASPHALT SURFACE REMOVAL, 2 1/4"
- ⑩ PROPOSED HOT-MIX ASPHALT SURFACE REMOVAL, 1 1/2"
- ⑪ PROPOSED HOT-MIX ASPHALT SURFACE COURSE, MIX "D", N70, 1 1/2"
- ⑫ PROPOSED POLY. LEVELING BINDER (MACHINE METHOD), IL-4.75, N50, 3/4"
- ⑬ PROPOSED AGGREGATE WEDGE SHOULDER, TYPE B
- ⑭ PROPOSED GRADING AND SHAPING SHOULDER
- ⑮ PROPOSED SAFETY EDGE WHEN HMA SHOULDER < 3 FT (30°, 5" DEPTH MAX)

FILE NAME =	USER NAME = midyja	DESIGNED -	REVISED -	<b>STATE OF ILLINOIS DEPARTMENT OF TRANSPORTATION</b>	<b>ILL 171 EXISTING &amp; PROPOSED TYPICAL SECTIONS</b>		F.A.P. RTE. 577	SECTION D-RS-7	COUNTY WILL	TOTAL SHEETS 38	SHEET NO. 7	
ct:\pw\work\pwidot\midyja\0248692\013301-ahst-pln.dgn		DRAWN -	REVISED -		SCALE:	SHEET NO. 1 OF 1 SHEETS	STA. +	TO STA. +	CONTRACT NO. 60N60			
		CHECKED -	REVISED -		FED. ROAD DIST. NO. 1 (ILLINOIS) FED. AID PROJECT							
		DATE -	REVISED -									