

F.A.P. RTE.	SECTION	COUNTY	TOTAL SHEETS	SHEET NO.
303	129K-1	WINNEBAGO	401	1
FED. ROAD DIST. NO. 2		ILLINOIS	CONTRACT NO. 64987	

STATE OF ILLINOIS
DEPARTMENT OF TRANSPORTATION
DIVISION OF HIGHWAYS

**PROPOSED
HIGHWAY PLANS**

FAP ROUTE 303 (IL 173)
SECTION 129K-1
PROJECT: NHF-0303 (053)
ROADWAY RECONSTRUCTION AND
INTERSECTION IMPROVEMENTS
WINNEBAGO COUNTY

D-92-034-04

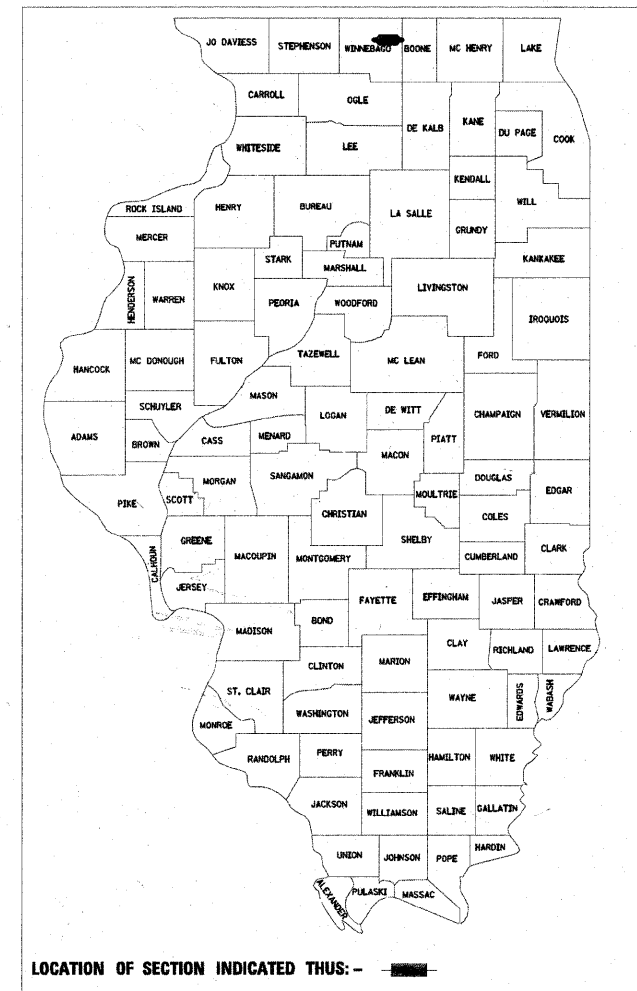

FOR INDEX OF SHEETS, SEE SHEET NO. 2
FOR LIST OF STANDARDS, SEE SHEET NO. 2

DESIGN DESIGNATION:

IL 173 - 3490 (25) PRINCIPAL ARTERIAL 6.03 (PCC-40)
IL 251 - 2715 (25) PRINCIPAL ARTERIAL 6.03 (PCC-40)

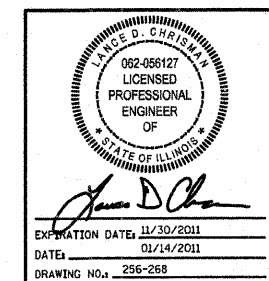
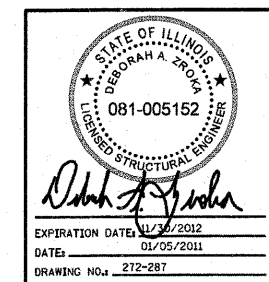
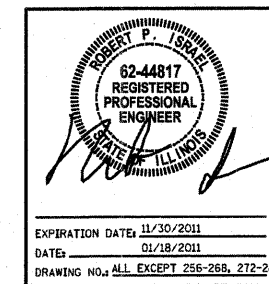
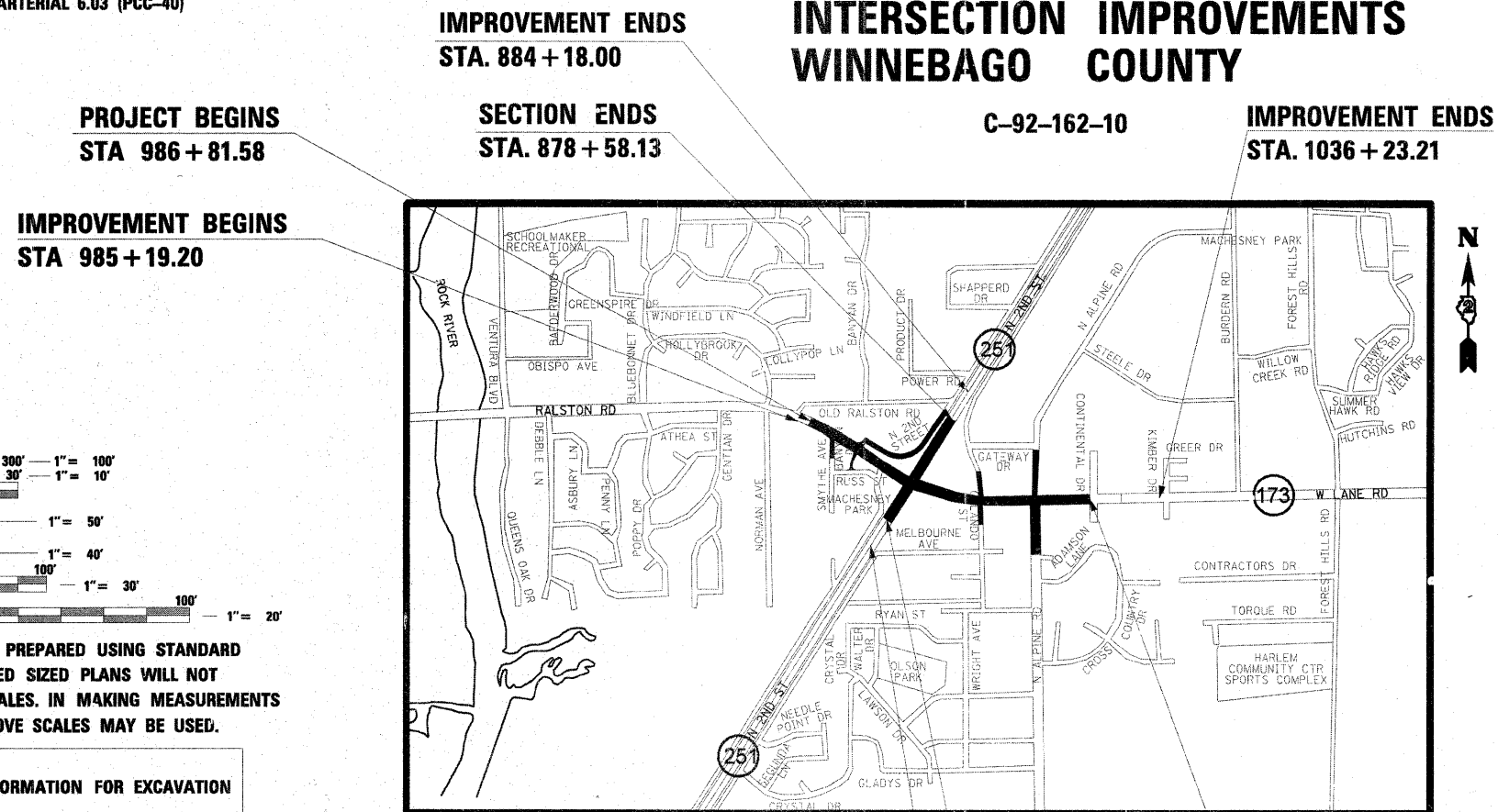

STATE OF ILLINOIS
DEPARTMENT OF TRANSPORTATION
DIVISION OF HIGHWAYS

SUBMITTED JAN 20 20 11

DEPUTY DIRECTOR OF HIGHWAYS, REGION ENGINEER

May 13 20 11

Scott E. Skutt, P.E. I.E.

ENGINEER OF DESIGN AND ENVIRONMENT

May 13 20 11

Christine M. Reed, I.E.

DIRECTOR OF HIGHWAYS, CHIEF ENGINEER

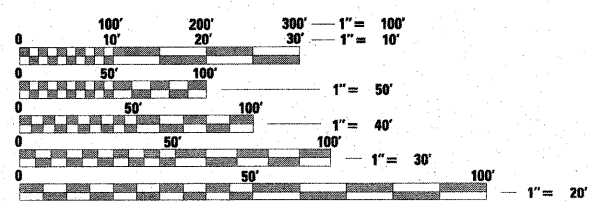

FULL SIZE PLANS HAVE BEEN PREPARED USING STANDARD ENGINEERING SCALES. REDUCED SIZED PLANS WILL NOT CONFORM TO STANDARD SCALES. IN MAKING MEASUREMENTS ON REDUCED PLANS, THE ABOVE SCALES MAY BE USED.

J.U.L.I.E.
JOINT UTILITY LOCATION INFORMATION FOR EXCAVATION
1-800-892-0123
OR 811

PROJECT ENGINEER: MASOOD AHMAD (815) 284-5510
PROJECT MANAGER: TRACI HELFRICH (815) 284-5932
(EMAIL: traci.helfrich@illinois.gov)
ENGINEERING CONSULTANT: ROBERT ISRAEL (773) 693-6030
CONTRACT NO. 64987

SECTION 17, 18, 19, 20
HARLEM TOWNSHIP

FAP ROUTE 303 (IL 173) SECTION 129K-1

IMPROVEMENT BEGINS STA. 857 + 37.46
SECTION BEGINS STA. 862 + 93.96
PROJECT ENDS STA. 1028 + 00.00

GROSS LENGTH = 4118.42 FT. = 0.780 MILE
NET LENGTH = 4118.42 FT. = 0.780 MILE
GROSS LENGTH (IL 251) = 1564.17 FT. = 0.296 MILE
NET LENGTH (IL 251) = 1564.17 FT. = 0.296 MILE

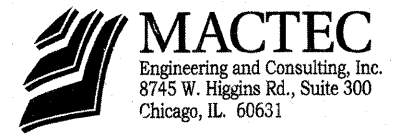

PRINTED BY THE AUTHORITY
OF THE STATE OF ILLINOIS

INDEX OF SHEETS

1 COVER SHEET
 2 INDEX OF SHEETS AND LIST OF STANDARDS
 3-4 GENERAL NOTES AND COMMITMENTS
 5-13 SUMMARY OF QUANTITIES
 14-24 TYPICAL SECTIONS
 25 SCHEDULES OF QUANTITIES
 26-27 EARTHWORK SCHEDULE
 28 SCHEDULE OF QUANTITIES
 29 PAVEMENT SCHEDULE
 30 SCHEDULE OF QUANTITIES
 31-36 DRAINAGE SCHEDULE
 37 SCHEDULE OF QUANTITIES
 38 ADJUSTING SERVICE LINES SCHEDULE
 39-49 SCHEDULE OF QUANTITIES
 50-54 HORIZONTAL AND VERTICAL CONTROL
 55-60 EXISTING AND REMOVAL PLAN
 61-72 PLAN AND PROFILE
 73-74 ROADWAY DETAILS
 75 GRADING PLAN
 76-154 STAGING AND TRAFFIC CONTROL
 155-224 STORM WATER POLLUTION PREVENTION PLAN
 & TEMPORARY DRAINAGE
 225-230 RIGHT OF WAY PLAN
 231-240 DRAINAGE AND UTILITY PLAN
 241-248 INTERSECTION DETAILS
 249-255 PAVEMENT MARKING PLAN
 256-268 TRAFFIC SIGNAL PLANS
 269-271 CHANNEL WALL DETAILS
 272-287 BOX CULVERT PLANS
 288 CATCH BASIN OR INLETS TO BE ADJUSTED OR RECONSTRUCTED (17.4)
 GRADING AROUND WINGWALLS (20.4)
 HOT-MIX ASPHALT SHOULDER (23.4A)
 THRUST BLOCK DETAILS (34.4)
 289 DELINEATOR AND POST ORIENTATION (37.4)
 REQUIRED COLD MILLED SURFACE TEXTURE (43.4)
 INLET SPECIAL NO. 3 (79.4)
 INLET SPECIAL NO. 5 (79.4B)
 290 INLET SPECIAL NO. 7 (79.4D)
 INLET SPECIAL NO. 8 (79.4E)
 NOSE TYPE FOR INLET TOP SLAB (79.4F)
 INLET SPECIAL NO. 3, 4, 5, 6 REINFORCEMENT DETAIL (79.4G)
 291 INLET SPECIAL NO. 7 AND 8 REINFORCEMENT DETAIL (79.4H)
 TYPICAL MARKING FOR PAINTED ISLANDS (93.4)
 TYPICAL MEDIAN CROSSOVER CLOSURE (98.4)
 292 STANDARD INLET FOR CURB AND GUTTER TYPE B-6.24 (21.2)
 WITNESS MARKER FOR PERMANENT SURVEY MARKERS TYPE II (66.2)
 293 NAME PLATE FOR CULVERTS (88.2)
 TRAFFIC CONTROL AND PROTECTION AT TURN BAYS (TO REMAIN OPEN TO TRAFFIC) (94.2)
 294 MAILBOX TURNOUT IN CURB AND GUTTER SECTION (3.1)
 295 HOT-MIX ASPHALT AND MAILBOX RETURNS (20.1)
 296 ENTRANCE APPROACHES - URBAN AREAS (25.1)
 297 SEWER AND WATER MAIN CROSSINGS (32.1)
 298 TRAFFIC CONTROL FOR ROAD CLOSURE (40.1)
 299 TYPICAL PAVEMENT MARKINGS SHEET 1 OF 3 (41.1)
 300 TYPICAL PAVEMENT MARKINGS SHEET 2 OF 3 (41.1)
 301 TYPICAL PAVEMENT MARKINGS SHEET 3 OF 3 (41.1)

INDEX OF SHEETS CONTINUED

302 SLOTTED DRAIN PIPE (68.1)
 303 BEVELED PIPE & GUARD DETAIL FOR MEDIAN CROSS OVER (86.1)
 304 DETAILS OF PLANTING AND BRACING TREES (92.1)
 305 CROSS SECTIONS KEY PLAN
 306-401 CROSS SECTIONS

LIST OF IDOT STANDARDS

STANDARD NO. DESCRIPTION
 000001-06 STANDARD SYMBOLS, ABBREVIATIONS AND PATTERNS
 001001-02 AREAS OF REINFORCEMENT BARS
 001006 DECIMAL OF AN INCH AND OF A FOOT
 280001-05 TEMPORARY EROSION CONTROL SYSTEMS
 353001-04 PCC BASE COURSE WITH HMA BINDER AND SURFACE COURSES
 420001-07 PAVEMENT JOINTS
 420101-04 24' (7.2 m) JOINTED PCC PAVEMENT
 420106-04 36' (10.8 m) JOINTED PCC PAVEMENT
 420111-03 PCC PAVEMENT ROUNDOUTS
 483001-04 PCC SHOULDER
 542201-02 REINFORCED CONCRETE END SECTIONS FOR PIPE CULVERTS 15" THRU 36" DIA.
 SKEWED WITH ROADWAY
 602301-03 INLET - TYPE A
 602306-03 INLET - TYPE B
 602401-03 MANHOLE TYPE A
 602406-04 MANHOLE TYPE A 6' (1.8 m) DIAMETER
 602411-02 MANHOLE TYPE A 7' (2.1 m) DIAMETER
 602601-02 PRECAST REINFORCED CONCRETE FLAT SLAB TOP
 602701-02 MANHOLE STEPS
 604001-03 FRAME AND LIDS TYPE 1
 604051-03 FRAME AND GRATE TYPE 11
 604091-02 FRAME AND GRATE TYPE 24
 606001-04 CONCRETE CURB TYPE B AND COMBINATION CONCRETE CURB AND GUTTER
 606006-02 OUTLETS FOR CONCRETE CURB AND GUTTER, TYPE B-6.24 (B-15.60)
 606301-04 PC CONCRETE ISLANDS AND MEDIANS
 606306-03 CORRUGATED PC CONCRETE MEDIANS

LIST OF IDOT STANDARDS

STANDARD NO. DESCRIPTION
 630001-09 STEEL PLATE BEAM GUARDRAIL
 630101-09 GUARDRAIL MOUNTED ON EXISTING CULVERTS
 630201-06 PCC/HMA STABILIZATION AT STEEL PLATE BEAM GUARDRAIL
 630301-05 SHOULDER WIDENING FOR TYPE 1 (SPECIAL) GUARDRAIL TERMINALS
 631011-07 TRAFFIC BARRIER TERMINAL, TYPE 2
 635001-01 DELINEATORS
 635006-03 REFLECTOR AND TERMINAL MARKER PLACEMENT
 635011-02 REFLECTOR MARKER AND MOUNTING DETAILS
 701006-03 OFF-RD OPERATIONS, 2L, 2W, 15' (4.5 m) TO 24" (600 mm) FROM PAVEMENT EDGE
 701101-02 OFF-RD OPERATIONS, MULTILANE, 15' (4.5 m) TO 24" (600 mm) FROM PAVEMENT EDGE
 701106-02 OFF-RD OPERATIONS, MULTILANE, MORE THAN 15' (4.5m) AWAY
 701201-04 LANE CLOSURE, 2L, 2W, DAY ONLY, FOR SPEEDS ≥ 45 MPH
 701206-03 LANE CLOSURE, 2L, 2W, NIGHT ONLY, FOR SPEEDS ≥ 45 MPH
 701301-04 LANE CLOSURE, 2L, 2W, SHORT TIME OPERATIONS
 701306-03 LANE CLOSURE, 2L, 2W, SLOW MOVING OPERATIONS DAY ONLY, FOR SPEEDS ≥ 45 MPH
 701422-03 LANE CLOSURE, MULTILANE, FOR SPEEDS ≥ 45 MPH TO 55 MPH
 701426-04 LANE CLOSURE, MULTILANE, INTERMITTENT OR MOVING OPER., FOR SPEEDS ≥ 45 MPH
 701606-07 URBAN LANE CLOSURE, MULTILANE, 2W WITH MOUNTABLE MEDIAN
 701701-07 URBAN LANE CLOSURE, MULTILANE INTERSECTION
 701901-01 TRAFFIC CONTROL DEVICES
 704001-06 TEMPORARY CONCRETE BARRIER
 720001-01 SIGN PANEL MOUNTING DETAILS
 720006-02 SIGN PANEL ERECTION DETAILS
 720011-01 METAL POSTS FOR SIGNS, MARKERS AND DELINEATORS
 720016-02 MAST ARM MOUNTED STREET NAME SIGNS
 728001-01 TELESCOPING STEEL SIGN SUPPORT
 729001-01 APPLICATIONS OF TYPES A & B METAL POSTS (FOR SIGNS & MARKERS)
 780001-02 TYPICAL PAVEMENT MARKINGS
 781001-03 TYPICAL APPLICATIONS RAISED REFLECTIVE PAVEMENT MARKERS
 805001-01 ELECTRICAL SERVICE INSTALLATION DETAILS
 814001-02 HANDHOLES
 814006-02 DOUBLE HANDHOLES
 857001-01 STANDARD PHASE DESIGNATION DIAGRAMS AND PHASE SEQUENCES
 873001-02 TRAFFIC SIGNAL GROUNDING & BONDING
 877011-04 STEEL COMBINATION MAST ARM ASSEMBLY AND POLE 16' THROUGH 55'
 877012-01 STEEL COMBINATION MAST ARM ASSEMBLY AND POLE 56' THROUGH 75'
 878001-08 CONCRETE FOUNDATION DETAILS
 880001-01 SPAN WIRE MOUNTED SIGNALS AND FLASHING BEACON INSTALLATION
 880006-01 TRAFFIC SIGNAL MOUNTING DETAILS

- SEE CROSS SECTIONS FOR SPECIAL DITCHES AND BACKSLOPES.
- THE FINAL TOP 4" OF SOIL IN ANY RIGHT-OF-WAY AREA DISTURBED BY THE CONTRACTOR MUST BE CAPABLE OF SUPPORTING VEGETATION. THE SOIL MUST BE FROM THE A HORIZON (ZERO TO 2" DEEP) OF SOIL PROFILES OF LOCAL SOILS.
- THE REMOVAL OF BITUMINOUS SURFACING NOT ON A RIGID TYPE BASE REMOVED IN CONJUNCTION WITH THE BASE SHALL BE REMOVED AS EARTH EXCAVATION. THE REMOVAL OF BITUMINOUS SURFACING ON A RIGID TYPE BASE REMOVED IN CONJUNCTION WITH THE BASE SHALL BE INCLUDED IN THE CONTRACT UNIT PRICE FOR PAVEMENT REMOVAL OF THE TYPE SPECIFIED.
- ALL BORROW/WASTE/USE SITES MUST BE APPROVED BY THE DEPARTMENT PRIOR TO REMOVING ANY MATERIAL FROM THE PROJECT OR INITIATING ANY EARTH MOVING ACTIVITIES, INCLUDING TEMPORARY STOCKPILING OUTSIDE THE LIMITS OF CONSTRUCTION.
- THE CONTRACTOR SHALL SEED ALL DISTURBED AREAS WITHIN THE PROJECT LIMITS. SEEDING CLASS 4 OR 2A SHALL BE USED, EXCEPT IN FRONT OF PROPERTIES WHERE THE GRASS WILL BE MOWED, THEN USE SEEDING, CLASS 1. CLASS 2A SHALL BE USED ON FRONT SLOPES AND DITCH BOTTOMS. CLASS 4 SHALL BE USED BEHIND TYPE A GUTTER, ON ALL BACKSLOPES AND AREAS BEHIND THE BACKSLOPE, AND BEYOND THE TOE OF FRONT SLOPE ON FILL SECTIONS WITHOUT DITCHES.
- PREVIOUSLY PUGMILLED STOCKPILES OF "TYPE A" OLDER THAN 1 MONTH WILL NOT BE APPROVED FOR USE UNTIL A MOISTURE CHECK IS RUN TO VERIFY MOISTURE CONTENT. MATERIAL SHIPPED TO PROJECTS WITHOUT BEING TESTED WILL NOT BE ACCEPTED.
- PLACEMENT AND COMPACTION OF THE BACKFILL FOR PROPOSED ACROSS ROAD CULVERTS AND EXISTING ACROSS ROAD CULVERTS THAT ARE REMOVED SHALL CONFORM TO SECTION 502.10 OF THE STANDARD SPECIFICATIONS, EXCEPT THAT THE MATERIAL SHALL CONFORM TO ARTICLE 208.02 OF THE STANDARD SPECIFICATIONS, AND SHALL BE COMPACTED TO A MINIMUM OF 95% OF THE STANDARD LABORATORY DENSITY. ANY MATERIAL CONFORMING TO THE REQUIREMENTS OF ARTICLE 1003.04 OR 1004.05 WHICH HAS BEEN EXCAVATED FROM THE TRENCHES SHALL BE USED FOR BACKFILLING THE TRENCHES. THE ENTIRE EXCAVATION, WITHIN 2 FEET OUTSIDE OF EACH SHOULDER, SHALL BE BACKFILLED WITH TRENCH BACKFILL MATERIAL TO THE BOTTOM OF THE PROPOSED SUBGRADE. THIS TRENCH BACKFILL MATERIAL WILL NOT BE MEASURED FOR PAYMENT, BUT SHALL BE INCLUDED IN THE CONTRACT UNIT PRICE FOR THE CLASS OF CONCRETE INVOLVED OR OTHER UNIT PRICE ITEM OF THE WORK FOR WHICH IT IS REQUIRED.
- EXCEPT FOR THE TOP 3", ALL AGGREGATE BASES AND SUBBASES 12" IN THICKNESS SHALL BE CONSTRUCTED OF AGGREGATE GRADATION CA-2. IF THE SPECIFIED THICKNESS EXCEEDS 12", THE BASES OR SUBBASES SHALL BE CONSTRUCTED OF TOPSIZE 6" BREAKER-RUN CRUSHED STONE WITH 70% TO 90% BY WEIGHT, PASSING THE 4" SIEVE AND 15% TO 40% BY WEIGHT, PASSING THE 2" SIZE SIEVE, EXCEPT FOR THE TOP 3". THE BREAKER-RUN CRUSHED STONE SHALL BE REASONABLY UNIFORMLY GRADED FROM COARSE TO FINE AND BE TAKEN FROM A QUARRY LEDGE CAPABLE OF PRODUCING CLASS "D" QUALITY AGGREGATE. THE TOP 3" SHALL BE GRADATION CA-6 OR CA 10 REGARDLESS OF THICKNESS. THE WATER NECESSARY TO ACHIEVE COMPACTION IN ALL BUT THE TOP 3" LAYER MAY BE ADDED AFTER THE SUBBASE OR BASE COURSE IS PLACED ON THE GRADE.
- ALL EMBANKMENT CONSTRUCTED OF COHESIVE SOIL SHALL BE CONSTRUCTED WITH NOT MORE THAN 110% OF OPTIMUM MOISTURE CONTENT, DETERMINED BY THE STANDARD PROCTOR TEST. COHESIVE SOIL SHALL BE DEFINED AS ANY SOIL WHICH CONTAINS GREATER THAN 10% PARTICLES BY WEIGHT PASSING THE #200 SIEVE. THE 110% OF OPTIMUM MOISTURE LIMIT MAY BE WAIVED IN FREE-DRAINING GRANULAR MATERIAL WHEN APPROVED BY THE ENGINEER.
- THE EXISTING HOT-MIX ASPHALT ON PRIVATE AND COMMERCIAL ENTRANCES SHALL BE BLADED OFF OR MILLED AND DISPOSED OF OUTSIDE THE PROJECT LIMITS. THIS COULD BE THE ENTIRE ENTRANCE OR TAPERED AT THE END DEPENDING ON IF THE MAINLINE IS RESURFACED OR MILLED AND RESURFACED. THE COST OF THE BLADING, MILLING, ROLLING, AND DISPOSAL IS INCLUDED IN THE CONTRACT UNIT PRICE FOR INCIDENTAL HOT-MIX ASPHALT SURFACING.
- MILLING MACHINES ON THIS PROJECT SHALL BE CAPABLE OF REMOVING A LAYER OF BITUMINOUS A MINIMUM 6' WIDE AND 1-1/2 INCHES IN DEPTH IN A SINGLE PASS.

12. THE FOLLOWING MIXTURE REQUIREMENTS ARE APPLICABLE FOR THIS PROJECT:

MIXTURE USES(S):	IL 173/ALPINE RD			SMYTHE RD, BANYAN DR/N 2ND ST RUSS ST HMA OVERLAY, TEMP PAVEMENT		
	P SURFACE CSE	P LEV BINDER CSE	P BINDER CSE	SURFACE CSE	LEVEL BINDER CSE	BINDER CSE
PG:	SBS PG 70-22	SBS PG 70-22	SBS 70-22	PG 64-22	PG 64-22	PG 64-22
DESIGN AIR VOIDS	4.0% @ N70	4.0% @ N70	4.0% @ N70	4.0% @ N50	4.0% @ N50	4.0% @ N50
MIXTURE COMPOSITION (GRADATION MIXTURE)	IL 9.5 OR 12.5	IL 9.5	IL 19.0	IL 9.5 OR 12.5	IL 9.5	IL 19.0
FRICTION AGGREGATE	E	N/A	N/A	C	N/A	N/A
20 YEAR ESAL	4.2	4.2	4.2	0.7 MAX	0.2	0.7
MIX UNIT WEIGHT	119 LBS/SY/IN			112 LBS/SY/IN		

MIXTURE USES(S):	HMA SHOULDER/HMA MEDIAN	
	TOP	BOTTOM
PG:	PG 58-22	PG 58-22
DESIGN AIR VOIDS	3.0% @ N50	2.0% @ N50
MIXTURE COMPOSITION (GRADATION MIXTURE)	IL 9.5 OR 12.5	BAM
FRICTION AGGREGATE	C	N/A
20 YEAR ESAL	N/A	N/A
MIX UNIT WEIGHT	112 LBS/SY/IN	

- THE CONTRACTOR SHALL PLACE TEMPORARY HOT-MIX ASPHALT TAPERS ALONG ALL SIDES OF THE UTILITY STRUCTURES PROTRUDING ABOVE THE MILLED SURFACE. THE TEMPORARY TAPERS SHALL EXTEND 2" OUTSIDE OF THE CASTINGS, EXCEPT FOR THE APPROACH SIDE TO TRAFFIC SHALL HAVE A 4FT TAPER LENGTH. HOT-MIX ASPHALT MEETING THE APPROVAL OF THE ENGINEER SHALL BE USED, NO COLD MILLINGS WILL BE ALLOWED. THE COST OF THE MATERIAL, PLACEMENT, MAINTENANCE, REMOVAL AND DISPOSAL OF SAID WORK WILL BE INCLUDED IN THE PAY ITEM FOR HOT-MIX ASPHALT SURFACE REMOVAL.
- THE AREA TO BE PRIMED SHALL BE LIMITED TO THAT WHICH CAN BE COVERED WITH HMA THE SAME DAY, UNLESS OTHERWISE PERMITTED BY THE ENGINEER.
- 10' TRANSITIONS SHALL BE USED TO MATCH PROPOSED ITEMS OF WORK TO EXISTING ITEMS IN THE FIELD, UNLESS OTHERWISE SHOWN. THE TRANSITIONS SHALL BE PAID FOR AT THE CONTRACT UNIT PRICE FOR THE PROPOSED ITEM OF WORK SPECIFIED.
- ALL TEMPORARY SHEET PILING NECESSARY FOR THE PLACEMENT OF STORM SEWER, SANITARY SEWER AND WATERMAIN SHALL BE INCLUDED IN THE COST OF THE ITEM BEING INSTALLED.
- A NATIONWIDE 404 PERMIT HAS BEEN ISSUED FOR THIS PROJECT AND THE CONDITIONS OF THAT PERMIT MUST BE ADHERED TO.
- CULVERT FLOWS MUST BE MAINTAINED THROUGHOUT THE PROJECT. NORMAL FLOW SHALL BE ALLOWED TO PASS AT THE RATE IT ENTERS THE JOBSITE. HIGH FLOWS SHALL BE ALLOWED TO PASS WITHOUT CAUSING DAMAGE TO UPSTREAM PROPERTIES.
- THE BORING LOGS FOR THIS STRUCTURE INDICATE THAT GROUNDWATER LEVELS MAY ENCRONCH ON THE CONSTRUCTION LIMITS OF THIS CULVERT. IT SHALL BE THE RESPONSIBILITY OF THE CONTRACTOR TO CONTROL THE GROUND WATER AND DIVERT THE STREAM FLOW DURING CONSTRUCTION IN ORDER TO KEEP THE CONSTRUCTION AREA FREE OF WATER. THE METHOD OF CONTROLLING THE WATER SHALL BE SUBJECT TO APPROVAL OF THE ENGINEER AND THE COST SHALL BE INCLUDED IN THE CONTRACT UNIT PRICE FOR PRECAST CONCRETE BOX CULVERTS.
- THE CONTRACTOR SHALL INSTALL A 18" DIAMETER FORMED OPENING IN THE CONCRETE MEDIAN SURFACE OF THE ISLAND AS DIRECTED BY THE ENGINEER. ALSO, A 4" DIAMETER FORMED OPENING SHALL BE INSTALLED IN EACH CORNER OF THE ISLAND 1 FOOT BEHIND THE BACK OF CURB. ALL EXISTING PAVEMENT SURFACES OF OTHER EXISTING OBSTRUCTIONS BENEATH THESE OPENINGS SHALL BE REMOVED BY THE CONTRACTOR. AFTER THE MEDIAN IS IN PLACE THE 18" OPENING SHALL BE CORED DOWN 4' AND FILLED WITH DIRT. ALL COSTS INCURRED SHALL BE INCLUDED IN THE CONTRACT UNIT PRICE PER SQUARE FOOT FOR CONCRETE MEDIAN SURFACE, 4 INCH.
- THE PROPOSED PIPES FOR ENTRANCES AND SIDE ROADS SHALL BE PLACED IN LINE WITH THE EXISTING OR PROPOSED DITCH LINE.
- NOSES OF CURBED CORNER ISLANDS NOTED AS 1 & 2 ON HIGHWAY STANDARD 606301 SHALL BE RAMPED UNLESS THE CURB FUNCTION IS FOR THE PROTECTION OF PEDESTRIANS, SIGNALS, LIGHT STANDARDS OR SIGN TRUSS SUPPORTS.

- THE ISLANDS ON THIS PROJECT ARE INTERMEDIATE ISLANDS AS SHOWN ON THE INTERSECTION LAYOUT DETAILS.
- THE CONTRACTOR SHALL INSTALL 18" DIAMETER FORMED OPENINGS IN THE CONCRETE MEDIAN SURFACE, SPACED AT INTERVALS NO GREATER THAN 250 FEET, AND/OR AS DIRECTED BY THE ENGINEER. ALL EXISTING PAVEMENT SURFACES OR OTHER EXISTING OBSTRUCTIONS BENEATH THESE OPENINGS SHALL BE REMOVED BY THE CONTRACTOR. AFTER THE MEDIAN IS IN PLACE, CORE EACH OPENING DOWN 4' AND FILL WITH DIRT. ALL COSTS INCURRED SHALL BE INCLUDED IN THE CONTRACT UNIT PRICE PER SQUARE FOOT FOR P.C. CONCRETE MEDIAN SURFACE, 4 INCH.
- ALL FRAMES AND GRATES OF DRAINAGE STRUCTURES TO BE REMOVED OR FILLED SHALL BE CAREFULLY SALVAGED AND SHALL REMAIN THE PROPERTY OF CONTRACTOR.
- THE COST OF MAKING SEWER CONNECTIONS TO EXISTING DRAINAGE STRUCTURES SHALL BE INCLUDED IN THE VARIOUS CONTRACT UNIT PRICES FOR STORM SEWER.
- NOT USED
- FOR ALL DRAINAGE STRUCTURES IN CURB: 1) HORIZONTAL LOCATION OF STRUCTURE IS TO THE FACE OF CURB 2) ELEVATIONS ARE GIVEN AT THE EDGE OF PAVEMENT

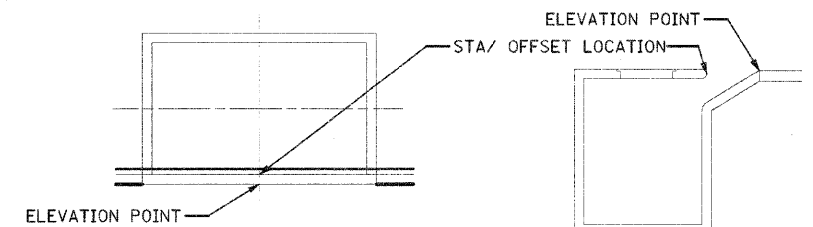

- THE NEW MANHOLE LIDS ON THIS PROJECT SHALL HAVE THE WORD "STORM", "SANITARY", OR "WATER" ON THE LID. THE WORD TO BE USED IS NOTED ON THE PLANS. IT WILL BE THE CONTRACTOR'S RESPONSIBILITY TO DETERMINE THE WORD TO BE USED ON OTHER LIDS NOT NOTED ON THE PLANS. NO ADDITIONAL COMPENSATION WILL BE ALLOWED FOR THIS WORK.
- ALL PROPOSED MANHOLES ON THIS PROJECT SHALL BE CAST IN PLACE OR PRECAST. THIS WORK WILL BE PAID FOR AT THE CONTRACT UNIT PRICE EACH FOR MANHOLE OF THE TYPE AND SIZE SPECIFIED.
- THE CONTRACTOR SHALL DETERMINE FLOW LINES OF EXISTING SEWER LINES WHICH ARE SHOWN ON THE PLANS AS ESTIMATED OR UNKNOWN. THIS INFORMATION IS NECESSARY BEFORE ORDERING INLETS AND MANHOLES.
- THE CONTRACTOR SHALL SUPPLY THE RESIDENT ENGINEER WITH THE MANUFACTURER'S INSTALLATION REQUIREMENTS FOR THE TYPE OF STEEL PLATE BEAM GUARDRAIL TERMINAL TYPE 1 SPECIAL (TANGENT) OR STEEL PLATE BEAM GUARDRAIL TERMINAL TYPE I SPECIAL (FLARED).
- DELINEATORS SHALL BE PLACED AT THE ENDS OF APPROACH GUARDRAIL TERMINAL SECTIONS, AND AT EACH HEADWALL OR END SECTION OF AR CULVERTS. THIS WORK WILL BE PAID FOR AT THE CONTRACT UNIT PRICE EACH FOR DELINEATORS.
- PAVEMENT MARKING SHALL BE DONE ACCORDING TO STANDARD 780001, EXCEPT AS FOLLOWS:
 - ALL WORDS, SUCH AS 'ONLY', SHALL BE 8 FEET HIGH.
 - ALL NON-FREEWAY ARROWS SHALL BE THE LARGE SIZE.
 - THE DISTANCE BETWEEN YELLOW NO-PASSING LINES SHALL BE (8'), NOT 7' AS SHOWN IN THE DETAIL OF TYPICAL LANE AND EDGE LINES.
- THE CONTRACTOR SHALL SUBMIT TO THE ENGINEER A DESCRIPTION OF LOCATION, ELEVATION, AND COORDINATES FOR EACH PERMANENT SURVEY MARKER. THE HORIZONTAL AND VERTICAL COORDINATES MUST BE DERIVED BY GPS AND THE ELEVATION DERIVED BY A CLOSED LEVEL CIRCUIT. THE ENGINEER SHALL SUBMIT THIS INFORMATION TO THE SURVEY CREW.
- PERMANENT SURVEY MARKERS, TYPE II SHALL BE CAST-IN-PLACE AS SHOWN ON DISTRICT STANDARD 66.2. THE BOTTOM OF THE MARKER SHALL BE 5'-0" BELOW THE GROUND SURFACE.

36. THE CONTRACTOR SHALL BE RESPONSIBLE FOR PROTECTING UTILITY PROPERTY DURING CONSTRUCTION OPERATIONS AS OUTLINED IN ARTICLE 107.31 OF THE STANDARD SPECIFICATIONS. A MINIMUM OF 48 HOURS ADVANCE NOTICE IS REQUIRED FOR NON-EMERGENCY WORK. THE JULIE NUMBER IS 800-892-0123. THE FOLLOWING LISTED UTILITIES LOCATED WITHIN THE PROJECT LIMITS OR IMMEDIATELY ADJACENT TO THE PROJECT CONSTRUCTION LIMITS ARE LISTED BELOW.

ROCK RIVER WATER RECLAMATION DISTRICT (SANITARY SEWER)
P.O. BOX 7480
3333 KISHWAUKEE
ROCKFORD, IL. 61126
815-387-7400

NICOR GAS CO.
1844 FERRY ROAD
NAPERVILLE, IL. 60563-9600
630-983-8676

VILLAGE OF MACHESNEY PARK (STORM SEWER)
300 MACHESNEY ROAD
MACHESNEY PARK, IL. 61115
815-877-5432

COMMONWEALTH EDISON
123 ENERGY AVENUE
ROCKFORD, IL. 61109
815-966-2757

NORTH PARK PUBLIC WATER DISTRICT (WATER)
1350 TURREY DRIVE
MACHESNEY PARK, IL. 61115
815-633-5461

COMCAST COMMUNICATIONS
4450 KISHWAUKEE STREET
ROCKFORD, IL. 61109
815-395-8977

AT&T
2404 8TH AVENUE
ROCKFORD, IL. 61108
815-394-7297

37. THE UTILITIES WHICH ARE NOT MEMBERS OF JULIE AND SHOULD BE NOTIFIED INDIVIDUALLY BY THE CONTRACTOR.
38. THE APPLICABLE PORTIONS OF ARTICLE 105.07 OF THE STANDARD SPECIFICATION SHALL APPLY EXCEPT FOR THE FOLLOWING: THE CONTRACTOR SHALL BE RESPONSIBLE TO LOCATE THE VERTICAL DEPTHS OF THE UNDERGROUND UTILITIES WHICH MAY INTERFERE WITH CONSTRUCTION OPERATIONS. THIS WORK WILL NOT BE MEASURED OR PAID FOR SEPARATELY, BUT SHALL BE CONSIDERED AS INCLUDED IN THE UNIT BID PRICE FOR THE ITEM OF CONSTRUCTION INVOLVED.
39. PER SB 699 (90 DAY UTILITY RELOCATION LAW), ONCE RIGHT-OF-WAY IS CLEAR TO AWARD THE PROJECT, A NOTICE WILL BE SENT TO THE UTILITY COMPANIES INSTRUCTING THEM TO HAVE THEIR FACILITIES RELOCATED WITHIN 90 DAYS. ESTIMATED DATE RELOCATION COMPLETE = LETTING DATE + 135 DAYS.
40. TIE BARS SHALL BE INSTALLED TO TIE PCC APPURTENANCE TO ADJACENT EXISTING CONCRETE PAVEMENT.

TIE THE FOLLOWING TO THE EXISTING CONCRETE PAVEMENT	LENGTH, SIZE, AND SPACING OF TIE BARS	
GUTTER OR CURB & GUTTER OR CONCRETE MEDIAN	STD. 606001	24" LONG NO. 20 (NO. 6) @ 24" CENTERS
PCC BASE COURSE	STD. 353001	24" LONG NO. 20 (NO. 6) @ 30" CENTERS
PCC PAVEMENT	STD. 420101	24" LONG NO. 20 (NO. 6) @ 30" CENTERS

41. TIE BARS TO BE INSTALLED IN ACCORDANCE WITH THE APPLICABLE PORTIONS OF ARTICLE 420.05(B) OF THE STANDARD SPECIFICATIONS. SEE HIGHWAY STANDARD 420001 FOR DETAIL ON LONGITUDINAL CONSTRUCTION JOINT GROUTED IN PLACE TIE BAR. THE COST OF THE TIE BARS TO BE INCLUDED IN THE COST OF THE PCC APPURTENANCE ADJACENT TO THE EXISTING PAVEMENT.
42. CADD DATA WILL BE AVAILABLE TO CONTRACTORS AND CONSULTANTS WORKING ON THIS PROJECT. THIS INFORMATION WILL BE PROVIDED UPON REQUEST AS MICROSTATION CADD FILES AND GEOPAK COORDINATE GEOMETRY FILES ONLY. IF DATA IS REQUIRED IN OTHER FORMATS IT WILL BE THE CONTRACTOR'S RESPONSIBILITY TO MAKE THESE CONVERSIONS. IF ANY DISCREPANCY OR INCONSISTENCY ARISES BETWEEN THE ELECTRONIC DATA AND THE INFORMATION ON THE HARD COPY, THE INFORMATION ON THE HARD COPY SHOULD BE USED. CONTACT THE DISTRICT'S PROJECT ENGINEER TO REQUEST THESE FILES.
43. IT SHALL BE THE CONTRACTOR'S RESPONSIBILITY TO CONTACT THE RRWRD/NPPWD TO DETERMINE APPROVED METHODS OF UTILITY STRUCTURE ADJUSTMENT. UTILITY STRUCTURES MAY INCLUDE, BUT ARE NOT LIMITED TO, MANHOLES, WATER VALVES, HANDHOLES, ETC. ALL MATERIALS AND WORK NECESSARY TO COMPLETE ADJUSTMENTS PER MUNICIPALITY REQUIREMENTS SHALL BE CONSIDERED INCLUDED IN THE COST OF THE ASSOCIATED ADJUSTMENT PAY ITEM.

44. THE SUBGRADE ON THIS PROJECT, EXCLUSIVE OF ROCK CUT AREAS IS SCHEDULED TO BE IMPROVED TO A 12" DEPTH ACCORDING TO MECHANISTIC PAVEMENT DESIGN. THE AREAS SCHEDULED TO BE IMPROVED TO A DEPTH GREATER THAN 12" ARE ESTIMATED BASED ON THE ORIGINAL GEOTECHNICAL INVESTIGATION. THE SUBGRADE SHALL BE PROCESSED IN ACCORDANCE WITH ARTICLE 301.03 OF THE STANDARD SPECIFICATIONS BEFORE THE ENGINEER SHALL DETERMINE THE LIMITS AND THE ADDITIONAL THICKNESS OF IMPROVEMENT REQUIRED, IF ANY. ANY ADDITIONAL UNDERCUTTING REQUIRED AFTER THIS EVALUATION SHALL BE PAID FOR AS EARTH EXCAVATION.
45. THE CONTRACTOR WILL BE REQUIRED TO FURNISH 5 1/2" HIGH BRASS STENCILS AS APPROVED BY THE ENGINEER AND INSTALL STATIONING AT 250' INTERVALS, STATIONING SHALL BE PLACED ON BOTH LANES OF 2-LANE HIGHWAYS AND ON THE OUTSIDE LANES IN BOTH DIRECTIONS ON 4-LANE HIGHWAYS. THE STATIONS SHALL BE PLACED 6" INSIDE THE PAVEMENT MARKING EDGE SO THEY CAN BE READ FROM THE SHOULDER. THIS WORK WILL BE INCLUDED IN THE COST OF THE FINAL PAVEMENT SURFACE.
46. ONE 16D GALVANIZED NAIL SHALL BE USED TO TOE NAIL THE WOOD BLOCK OUT TO THE WOOD POST ON ALL TRAFFIC BARRIER TERMINAL TYPE I SPECIALS.
47. DELINEATORS SHALL BE INSTALLED AS SHOWN IN STANDARD 635001, EXCEPT THAT THE POST SHALL BE ROTATED 180° AND ONLY METAL-BACKED DELINEATORS SHALL BE PERMITTED.
48. PERMANENT SURVEY MARKERS, TYPE II, SHALL BE SET AT INTERVALS OF 1 MILE OR AS DIRECTED BY THE ENGINEER. BRIDGE OR CULVERT PROJECTS SHALL HAVE ONE SURVEY MARKER PLACED NEAR THE STRUCTURE. ESTIMATED: 3 EACH
49. TREE PLANTING LAYOUT SHALL BE PERFORMED BY THE DISTRICT LANDSCAPE ARCHITECT. MULCH SHALL BE PLACED 4" THICK AND TO THE DIAMETER AROUND THE TREE AS SHOWN ON DISTRICT STANDARD 92.1. THE MULCH SHALL BE HARDWOOD WOOD CHIPS PLACED ON WEED BARRIER FABRIC. THIS WORK SHALL BE INCLUDED IN THE COST OF THE TREE.
50. ALL GUTTER OUTLETS SHALL BE EXTENDED TO DITCH FLOW AS DIRECTED BY THE ENGINEER.
51. THE CONTRACTOR SHALL PLACE CONTRACTION JOINT IN PROLONGATION WITH JOINTS IN THE EXISTING PAVEMENT. THE JOINT SHALL BE A SAWED CONTRACTION JOINT WITH DOWEL BAR ASSEMBLY AS SHOWN ON HIGHWAY STANDARD 420001. THE COST FOR THIS WORK SHALL BE INCLUDED IN THE CONTRACT UNIT PRICE FOR THE P.C.C. BASE COURSE.
52. SMYTHE AVENUE/RUSS STREET EXISTING PAVEMENT SHALL BE OVERLAYED BETWEEN SMYTHE AVENUE RECONSTRUCTION LIMIT (STA 42+30) AND SERVICE ROAD. THE FOLLOWING ITEMS SHALL BE USED FOR THIS WORK: 1.5" HMA SURFACE COURSE, MIX "C", N50 - 163 TON. 0.75" LEVELING BINDER (HAND METHOD), N50 - 112 TON. BITUMINOUS MATERIAL (PRIME COAT) - 0.6 TON. AGGREGATE (PRIME COAT) - 2.9 TON.
53. EXISTING TRAFFIC SIGNS SHALL BE CAREFULLY REMOVED AND SHALL REMAIN THE PROPERTY OF IDOT. REMOVED SIGNS SHALL BE STORED AS DIRECTED BY THE ENGINEER. THIS WORK SHALL NOT BE PAID SEPERATELY BUT WILL BE INCLUDED IN THE COST OF APPLICABLE TRAFFIC CONTROL AND PROTECTION STANDARDS.
54. TEMPORARY IMPACT ATTENUATORS THAT HAVE BEEN FURNISHED AND PLACED COULD BE RELOCATED ON THE SAME PROJECT. THE ATTENUATORS RELOCATED, FROM ONE STAGE TO ANOTHER, FROM THE PROJECT TO AN OFFSITE LOCATION, OR FROM THE OFFSITE LOCATION BACK TO THE PROJECT, WILL BE PAID FOR AT THE CONTRACT UNIT PRICE PER EACH FOR IMPACT ATTENUATORS RELOCATE OF THE PARTICULAR TYPE SPECIFIED.
55. TEMPORARY CONCRETE BARRIER THAT HAS BEEN FURNISHED AND PLACED COULD BE RELOCATED ON THE SAME PROJECT. THE TEMPORARY CONCRETE BARRIER RELOCATED, FROM ONE STAGE TO ANOTHER, FROM THE PROJECT TO AN OFFSITE LOCATION, OR FROM THE OFFSITE LOCATION BACK TO THE PROJECT, WILL BE PAID FOR AT THE CONTRACT UNIT PRICE PER FOOT FOR RELOCATE TEMPORARY CONCRETE BARRIER.
56. IT IS THE CONTRACTOR'S RESPONSIBILITY TO CONTACT MR. STEVE BUELOW OF THE ROCK RIVER WATER RECLAMATION DISTRICT (RRWRD) WHEN UTILITY WORK INVOLVES SANITARY MANHOLES AND THAT SANITARY CASTINGS AND LIDS SHALL BE REPLACED AS DETERMINED BY THE RRWRD. THE NEW CASTINGS AND LIDS WILL BE PROVIDED TO THE CONTRACTOR BY THE RRWRD AND THE EXISTING CASTINGS AND LIDS SHALL REMAIN THE PROPERTY OF THE RRWRD.
57. EXISTING PAVEMENT CORES WILL BE AVAILABLE TO CONTRACTORS AT THE DISTRICT. CONTACT THE DISTRICT'S PROJECT ENGINEER TO REQUEST THESE FILES.
58. THE CONTRACTOR MAY NOT PARK VEHICLES IN TEMPORARY EASEMENT (TE) AREAS. TE AREAS ARE TO BE UTILIZED ONLY WHEN CONSTRUCTION IS BEING DONE IN THE IMMEDIATE AREA.

COMMITMENTS

TREES CLOSE TO THE CONSTRUCTION LIMITS SHALL BE PROTECTED WITH TREE TRUNK PROTECTION PER STANDARD SPECIFICATION 201.10(c) (1).

ALL TREES REMOVED FROM THE PROJECT AREA FOR CONSTRUCTION OR MAINTENANCE PURPOSES WILL BE REPLACED WITH DECIDUOUS TREE SPECIES WHICH ARE NATIVE TO DISTRICT 2 AREA.

TREES WILL BE REPLACED ACCORDING TO IDOT DEPARTMENT POLICY D & E-18.

THE LOCATION OF THE REPLACEMENT TREES SHALL BE DETERMINED BY THE DISTRICT 2 LANDSCAPE ARCHITECT.

ACCORDING TO IDOT BDE PROCEDURE MEMORANDUM 99-34 AND OPERATIONS POLICY 5-1800, ALL UNMOWED AREAS SHOULD BE DESIGNATED IN THE PLANS AND SEEDED WITH THE APPROPRIATE NATIVE SEEDING SELECTIONS FROM CLASS 4.

THE VILLAGE IS INTERESTED IN HAVING IT'S CREW ON THE SITE TO TAKE APPROXIMATELY 50 BLOCKS DURING REMOVAL OF THE CHANNEL RETAINING WALLS. TO COORDINATE THIS ACTIVITY THE CONTRACTOR SHALL CONTACT CHRIS DOPKINS (815-636-9590) OR PAUL SHEPPARD (815-877-5432) PRIOR BEGINING OF RETAINING WALL REMOVAL.

FILE NAME = D264987-ahg-gemnote-003.dgn	USER NAME = 320209077	DESIGNED - LOM	REVISIONS -	STATE OF ILLINOIS DEPARTMENT OF TRANSPORTATION	GENERAL NOTES AND COMMITMENTS				F.A.P. RTE. 303	SECTION 129K-1	COUNTY WINNEBAGO	TOTAL SHEETS 401	SHEET NO. 4
		DRAWN - MD	REVISED -		SCALE:	SHEET NO.	OF	SHEETS	STA.	TO STA.	CONTRACT NO. 64987		
		CHECKED - PDK	REVISED -		FED. ROAD DIST. NO. 2 ILLINOIS FED. AID PROJECT								
		DATE 03-16-2011	REVISED -										

SUMMARY OF QUANTITIES

← LABEL → * STPCL → * STBAL →

CONSTRUCTION CODE

CODE NO.	ITEM	UNIT	TOTAL QUANTITY	80% FED	80% FED	80% FED	80% FED	80% FED	80% FED	80% FED	75% STATE	100% VILLAGE	100% FPD	100% RRWRD	100% NPPWD	
				20% STATE	20% STATE	20% STATE	20% STATE	20% STATE	20% STATE	10% COUNTY	25% VILLAGE		100% VILLAGE	100% FPD	100% RRWRD	100% NPPWD
				SN. 101-2051	SN. 101-2052	SN. 101-2052	SN. 101-2004	SN. 101-2004	SN. 101-2004	SN. 101-2004	SN. 101-2004		SN. 101-2004	SN. 101-2004	SN. 101-2004	SN. 101-2004
				ROADWAY	BOX CULVERT	BOX CULVERT	BOX CULVERT	RET WALL	TRAFF SIGNALS	TRAFF SIGNALS	TRAFF SIGNALS	ROADWAY	TRAFF SIGNALS	UTILITY	UTILITY	
				0003	0040	0040	0040	0040	0021	0021	0021	0021	0021	0043	0043	
				URBAN	URBAN	URBAN	URBAN	URBAN	URBAN	URBAN	URBAN	URBAN	URBAN	URBAN	URBAN	
20100110	TREE REMOVAL (6 TO 15 UNITS DIAMETER)	UNIT	765	765												
20100210	TREE REMOVAL (OVER 15 UNITS DIAMETER)	UNIT	287	287												
20101100	TREE TRUNK PROTECTION	EACH	36	36												
20200100	EARTH EXCAVATION	CU YD	45,079	45,079												
20201200	REMOVAL AND DISPOSAL OF UNSUITABLE MATERIAL	CU YD	10,909	10,909												
20400800	FURNISHED EXCAVATION	CU YD	2,477	2,477												
20800150	TRENCH BACKFILL	CU YD	3,520	3,520												
* 21101615	TOPSOIL FURNISH AND PLACE, 4"	SQ YD	60,975	60,975												
* 25000210	SEEDING, CLASS 2A	ACRE	8.50	8.50												
* 25000314	SEEDING, CLASS 4B	ACRE	0.50	0.50												
* 25000400	NITROGEN FERTILIZER NUTRIENT	POUND	988	988												
* 25000500	PHOSPHORUS FERTILIZER NUTRIENT	POUND	988	988												
* 25000600	POTASSIUM FERTILIZER NUTRIENT	POUND	988	988												
** 25000750	MOWING	ACRE	9.00	9												
* 25100115	MULCH, METHOD 2	ACRE	9.00	9.00												
* 25100630	EROSION CONTROL BLANKET	SQ YD	88,943	88,943												
* 25100900	TURF REINFORCEMENT MAT	SQ YD	2,611	2,611												
* 25200110	SODDING, SALT TOLERANT	SQ YD	17,603	17,603												
* 25200200	SUPPLEMENTAL WATERING	UNIT	158	158												
28000250	TEMPORARY EROSION CONTROL SEEDING	POUND	1,838	1,838												
28000305	TEMPORARY DITCH CHECKS	FOOT	588	588												
28000400	PERIMETER EROSION BARRIER	FOOT	23,790	23,790												
28000500	INLET AND PIPE PROTECTION	EACH	152	152												
28100105	STONE RIPRAP, CLASS A3	SQ YD	136	136												
28100109	STONE RIPRAP, CLASS A5	SQ YD	600	600												
28200200	FILTER FABRIC	SQ YD	600	600												
28500400	ARTICULATED BLOCK REVETMENT MAT	SQ YD	408	408												
31100910	SUBBASE GRANULAR MATERIAL, TYPE A 12"	SQ YD	72,665	72,665												
31100950	SUBBASE GRANULAR MATERIAL, TYPE A 21"	SQ YD	13,622	13,622												

* SPECIALTY ITEMS ** NON-PARTICIPATING ITEMS (100% STATE)

SUMMARY OF QUANTITIES

CODE NO.	ITEM	UNIT	TOTAL QUANTITY	CONSTRUCTION CODE														
				80% FED 20% STATE	80% FED 20% STATE SN. 101-2051	80% FED 20% STATE SN. 101-2052	80% FED 20% STATE SN. 101-2004	80% FED 20% STATE	80% FED 20% STATE	80% FED 10% COUNTY 10% VILLAGE	75% STATE 25% VILLAGE	100% VILLAGE	100% FPD	100% RRWRD	100% NPPWD			
				ROADWAY 0003 URBAN	BOX CULVERT 0040 URBAN	BOX CULVERT 0040 URBAN	BOX CULVERT 0040 URBAN	RET WALL 0040 URBAN	TRAFF SIGNALS 0021 URBAN	TRAFF SIGNALS 0021 URBAN	TRAFF SIGNALS 0021 URBAN	ROADWAY 0021 URBAN	TRAFF SIGNALS 0021 URBAN	UTILITY 0043 URBAN	UTILITY 0043 URBAN			
35102000	AGGREGATE BASE COURSE, TYPE B 8"	SQ YD	1,384	1,384														
35300500	PORTLAND CEMENT CONCRETE BASE COURSE 10"	SQ YD	84	84														
40201000	AGGREGATE FOR TEMPORARY ACCESS	TON	162	162														
40300200	BITUMINOUS MATERIALS (PRIME COAT)	TON	13.1	13.1														
40600215	POLYMERIZED BITUMINOUS MATERIALS (PRIME COAT)	TON	7.0	7.0														
40600300	AGGREGATE (PRIME COAT)	TON	23	23														
40600525	LEVELING BINDER (HAND METHOD), N50	TON	112	112														
40600837	POLYMERIZED LEVELING BINDER (MACHINE METHOD), N70	TON	153	153														
40600990	TEMPORARY RAMP	SQ YD	279	279														
40603080	HOT-MIX ASPHALT BINDER COURSE, IL-19.0, N50	TON	1,419	1,419														
40603235	POLYMERIZED HOT-MIX ASPHALT BINDER COURSE, IL-19.0, N70	TON	2,425	2,425														
40603310	HOT-MIX ASPHALT SURFACE COURSE, MIX "C", N50	TON	1,004	1,004														
40603565	POLYMERIZED HOT-MIX ASPHALT SURFACE COURSE, MIX "E", N70	TON	598	598														
40800050	INCIDENTAL HOT-MIX ASPHALT SURFACING	TON	182	182														
42000306	PORTLAND CEMENT CONCRETE PAVEMENT 8 1/4" (JOINTED)	SQ YD	2,559	2,559														
42000411	PORTLAND CEMENT CONCRETE PAVEMENT 9 1/2" (JOINTED)	SQ YD	59,782	59,782														
42300300	PORTLAND CEMENT CONCRETE DRIVEWAY PAVEMENT, 7 INCH	SQ YD	913	913														
44000100	PAVEMENT REMOVAL	SQ YD	52,956	52,956														
44000155	HOT-MIX ASPHALT SURFACE REMOVAL, 1 1/2"	SQ YD	259	259														
44000158	HOT-MIX ASPHALT SURFACE REMOVAL, 2 1/4"	SQ YD	2,664	2,664														
44000200	DRIVEWAY PAVEMENT REMOVAL	SQ YD	1,370	1,370														
44000500	COMBINATION CURB AND GUTTER REMOVAL	FOOT	12,001	12,001														
44003100	MEDIAN REMOVAL	SQ FT	10,151	10,151														
44004000	PAVED DITCH REMOVAL	FOOT	523	523														
44004250	PAVED SHOULDER REMOVAL	SQ YD	6,314	6,314														
48203021	HOT-MIX ASPHALT SHOULDERS, 6"	SQ YD	115	115														
48300410	PORTLAND CEMENT CONCRETE SHOULDERS 9 1/2"	SQ YD	3,594	3,594														
50100300	REMOVAL OF EXISTING STRUCTURES NO. 1	EACH	1			1												
50100400	REMOVAL OF EXISTING STRUCTURES NO. 2	EACH	1				1											

* SPECIALTY ITEMS ** NON-PARTICIPATING ITEMS		FILE NAME = 0264987-shl 500 001.dgn		USER NAME = 320209071		DESIGNED - LOM		REVISED -		STATE OF ILLINOIS DEPARTMENT OF TRANSPORTATION		SUMMARY OF QUANTITIES		F.A.P. RTE. 303		SECTION 129K-1		COUNTY WINNEBAGO		TOTAL SHEETS 401		SHEET NO. 6	
PLOT SCALE = 100.0000' / IN.		PLOT DATE = 3/16/2011		DRAWN - MD		CHECKED - PDK		DATE - 03-16-2011		SCALE:		SHEET NO. OF SHEETS STA.		TO STA.		FED. ROAD DIST. NO. 2		ILLINOIS FED. AID PROJECT		CONTRACT NO. 64987			

SUMMARY OF QUANTITIES

CODE NO.	ITEM	UNIT	TOTAL QUANTITY	CONSTRUCTION CODE													
				80% FED 20% STATE	80% FED 20% STATE SN. 101-2051	80% FED 20% STATE SN. 101-2052	80% FED 20% STATE SN. 101-2004	80% FED 20% STATE	80% FED 20% STATE	80% FED 10% COUNTY 10% VILLAGE	75% STATE 25% VILLAGE	100% VILLAGE	100% FPD	100% RRWRD	100% NPPWD		
				ROADWAY 0003 URBAN	BOX CULVERT 0040 URBAN	BOX CULVERT 0040 URBAN	BOX CULVERT 0040 URBAN	RET WALL 0040 URBAN	TRAFF SIGNALS 0021 URBAN	TRAFF SIGNALS 0021 URBAN	TRAFF SIGNALS 0021 URBAN	TRAFF SIGNALS 0021 URBAN	ROADWAY 0021 URBAN	TRAFF SIGNALS 0021 URBAN	UTILITY 0043 URBAN	UTILITY 0043 URBAN	
50102400	CONCRETE REMOVAL	CU YD	67.3	55.0			12.3										
50104400	CONCRETE HEADWALL REMOVAL	EACH	2	2													
50105220	PIPE CULVERT REMOVAL	FOOT	3,710	3,710													
50200100	STRUCTURE EXCAVATION	CU YD	1,988					1,988									
50800105	REINFORCEMENT BARS	POUND	65,360		26,230	22,490	16,640										
50800205	REINFORCEMENT BARS, EPOXY COATED	POUND	440		220	110	110										
51500100	NAME PLATES	EACH	2		1	1											
54002020	EXPANSION BOLTS 3/4 INCH	EACH	90				90										
54003000	CONCRETE BOX CULVERTS	CU YD	368		162.1	139.2	67.0										
54011106	PRECAST CONCRETE BOX CULVERTS 11' X 6'	FOOT	1,060		664	396											
54213657	PRECAST REINFORCED CONCRETE FLARED END SECTIONS 12"	EACH	13	13													
54213660	PRECAST REINFORCED CONCRETE FLARED END SECTIONS 15"	EACH	5	5													
54213663	PRECAST REINFORCED CONCRETE FLARED END SECTIONS 18"	EACH	3	3													
54213669	PRECAST REINFORCED CONCRETE FLARED END SECTIONS 24"	EACH	3	3													
54213675	PRECAST REINFORCED CONCRETE FLARED END SECTIONS 30"	EACH	1	1													
550A0050	STORM SEWERS, CLASS A, TYPE 1 12"	FOOT	1,950	1,950													
550A0070	STORM SEWERS, CLASS A, TYPE 1 15"	FOOT	914	914													
550A0090	STORM SEWERS, CLASS A, TYPE 1 18"	FOOT	198	198													
550A0110	STORM SEWERS, CLASS A, TYPE 1 21"	FOOT	331	331													
550A0120	STORM SEWERS, CLASS A, TYPE 1 24"	FOOT	565	565													
550A0140	STORM SEWERS, CLASS A, TYPE 1 30"	FOOT	278	278													
550A0160	STORM SEWERS, CLASS A, TYPE 1 36"	FOOT	25	25													
550A0340	STORM SEWERS, CLASS A, TYPE 2 12"	FOOT	599	599													
550A0360	STORM SEWERS, CLASS A, TYPE 2 15"	FOOT	157	157													
550A0380	STORM SEWERS, CLASS A, TYPE 2 18"	FOOT	125	125													
550A0400	STORM SEWERS, CLASS A, TYPE 2 21"	FOOT	700	700													
550A0410	STORM SEWERS, CLASS A, TYPE 2 24"	FOOT	162	162													
550A0430	STORM SEWERS, CLASS A, TYPE 2 30"	FOOT	118	118													
550A0450	STORM SEWERS, CLASS A, TYPE 2 36"	FOOT	117	117													

SUMMARY OF QUANTITIES

CODE NO.	ITEM	UNIT	TOTAL QUANTITY	CONSTRUCTION CODE													
				80% FED 20% STATE	80% FED 20% STATE SN. 101-2051	80% FED 20% STATE SN. 101-2052	80% FED 20% STATE SN. 101-2004	80% FED 20% STATE	80% FED 20% STATE	80% FED 10% COUNTY 10% VILLAGE	75% STATE 25% VILLAGE	100% VILLAGE	100% FPD	100% RRWRD	100% NPPWD		
				ROADWAY 0003 URBAN	BOX CULVERT 0040 URBAN	BOX CULVERT 0040 URBAN	BOX CULVERT 0040 URBAN	RET WALL 0040 URBAN	TRAFF SIGNALS 0021 URBAN	TRAFF SIGNALS 0021 URBAN	TRAFF SIGNALS 0021 URBAN	ROADWAY 0021 URBAN	TRAFF SIGNALS 0021 URBAN	UTILITY 0043 URBAN	UTILITY 0043 URBAN		
550A0480	STORM SEWERS, CLASS A, TYPE 2 48"	FOOT	798	798													
56100700	WATER MAIN 8"	FOOT	125														125
56105000	WATER VALVES 8"	EACH	1														1
56400100	FIRE HYDRANTS TO BE MOVED	EACH	2	1													1
56400500	FIRE HYDRANTS TO BE REMOVED	EACH	2														2
56400810	FIRE HYDRANT EXTENSION	FOOT	20	10													10
56400820	FIRE HYDRANT WITH AUXILIARY VALVE AND VALVE BOX	EACH	2	1													1
56500600	DOMESTIC WATER SERVICE BOXES TO BE ADJUSTED	EACH	2														2
56500700	DOMESTIC WATER SERVICE BOXES TO BE REMOVED	EACH	3														3
60218400	MANHOLES, TYPE A, 4'-DIAMETER, TYPE 1 FRAME, CLOSED LID	EACH	4	4													
60219300	MANHOLES, TYPE A, 4'-DIAMETER, TYPE 11 FRAME AND GRATE	EACH	3	3													
60221700	MANHOLES, TYPE A, 5'-DIAMETER, TYPE 8 GRATE	EACH	1	1													
60223700	MANHOLES, TYPE A, 6'-DIAMETER, TYPE 1 FRAME, OPEN LID	EACH	1	1													
60224446	MANHOLES, TYPE A, 7'-DIAMETER, TYPE 1 FRAME, CLOSED LID	EACH	1	1													
60224449	MANHOLES, TYPE A, 7'-DIAMETER, TYPE 24 FRAME AND GRATE	EACH	1	1													
60236200	INLETS, TYPE A, TYPE 8 GRATE	EACH	3	3													
60236800	INLETS, TYPE A, TYPE 11 FRAME AND GRATE	EACH	1	1													
60240215	INLETS, TYPE B, TYPE 1 FRAME, CLOSED LID	EACH	1	1													
60240310	INLETS, TYPE B, TYPE 11 FRAME AND GRATE	EACH	8	8													
60255500	MANHOLES TO BE ADJUSTED	EACH	7	7													
60260100	INLETS TO BE ADJUSTED	EACH	6	6													
60265700	VALVE VAULTS TO BE ADJUSTED	EACH	2														2
60266100	VALVE VAULTS TO BE RECONSTRUCTED	EACH	3														3
60266600	VALVE BOXES TO BE ADJUSTED	EACH	14	3													11
60500040	REMOVING MANHOLES	EACH	7	7													
60500060	REMOVING INLETS	EACH	35	35													
60500070	REMOVING MANHOLES TO MAINTAIN FLOW	EACH	1													1	
60600095	CLASS SI CONCRETE (OUTLET)	CU YD	15	15													
60603500	COMBINATION CONCRETE CURB AND GUTTER, TYPE B-6.06	FOOT	844	844													
60603800	COMBINATION CONCRETE CURB AND GUTTER, TYPE B-6.12	FOOT	3,305	3,305													

SUMMARY OF QUANTITIES

CONSTRUCTION CODE

CODE NO.	ITEM	UNIT	TOTAL QUANTITY	CONSTRUCTION CODE														
				80% FED 20% STATE	80% FED 20% STATE SN. 101-2051	80% FED 20% STATE SN. 101-2052	80% FED 20% STATE SN. 101-2004	80% FED 20% STATE	80% FED 20% STATE	80% FED 10% COUNTY 10% VILLAGE	75% STATE 25% VILLAGE	100% VILLAGE	100% FPD	100% RRWRD	100% NPPWD			
				ROADWAY 0003 URBAN	BOX CULVERT 0040 URBAN	BOX CULVERT 0040 URBAN	BOX CULVERT 0040 URBAN	RET WALL 0040 URBAN	TRAFF SIGNALS 0021 URBAN	TRAFF SIGNALS 0021 URBAN	TRAFF SIGNALS 0021 URBAN	TRAFF SIGNALS 0021 URBAN	ROADWAY 0021 URBAN	TRAFF SIGNALS 0021 URBAN	UTILITY 0043 URBAN	UTILITY 0043 URBAN		
60604400	COMBINATION CONCRETE CURB AND GUTTER, TYPE B-6.18	FOOT	2,605	2,605														
60605000	COMBINATION CONCRETE CURB AND GUTTER, TYPE B-6.24	FOOT	16,913	16,913														
60608600	COMBINATION CONCRETE CURB AND GUTTER, TYPE M-6.06	FOOT	456	456														
60610400	COMBINATION CONCRETE CURB AND GUTTER, TYPE M-6.24	FOOT	622	622														
60618208	HOT-MIX ASPHALT MEDIAN	SQ FT	20,887	20,887														
60618300	CONCRETE MEDIAN SURFACE, 4 INCH	SQ FT	465	465														
60619200	CONCRETE MEDIAN, TYPE SB-6.06	SQ FT	378	378														
60624600	CORRUGATED MEDIAN	SQ FT	1,629	1,629														
* 63000001	STEEL PLATE BEAM GUARDRAIL, TYPE A, 6 FOOT POSTS	FOOT	475.0	475.0														
* 63000025	STEEL PLATE BEAM GUARDRAIL, ATTACHED TO STRUCTURES	FOOT	112.5	112.5														
* 63100045	TRAFFIC BARRIER TERMINAL, TYPE 2	EACH	2	2														
* 63100169	TRAFFIC BARRIER TERMINAL, TYPE 1 (SPECIAL) FLARED	EACH	2	2														
63200310	GUARDRAIL REMOVAL	FOOT	1,218	1,218														
63500105	DELINEATORS	EACH	8	8														
66700305	PERMANENT SURVEY MARKERS, TYPE II	EACH	3	3														
67000400	ENGINEER'S FIELD OFFICE, TYPE A	CAL MO	24	24														
67100100	MOBILIZATION	L SUM	1	1														
70100320	TRAFFIC CONTROL AND PROTECTION, STANDARD 701422	L SUM	1	1														
70102625	TRAFFIC CONTROL AND PROTECTION, STANDARD 701606	L SUM	1	1														
70102635	TRAFFIC CONTROL AND PROTECTION, STANDARD 701701	L SUM	1	1														
70103815	TRAFFIC CONTROL SURVEILLANCE	CAL DA	128	128														
70106800	CHANGEABLE MESSAGE SIGN	CAL MO	84	84														
70300100	SHORT TERM PAVEMENT MARKING	FOOT	2,000	2,000														
70300210	TEMPORARY PAVEMENT MARKING LETTERS AND SYMBOLS	SQ FT	6,057	6,057														
70300220	TEMPORARY PAVEMENT MARKING - LINE 4"	FOOT	207,627	207,627														
70300250	TEMPORARY PAVEMENT MARKING - LINE 8"	FOOT	23,572	23,572														
70300280	TEMPORARY PAVEMENT MARKING - LINE 24"	FOOT	3,801	3,801														
70301000	WORK ZONE PAVEMENT MARKING REMOVAL	SQ FT	45,940	45,940														

SUMMARY OF QUANTITIES

CONSTRUCTION CODE

CODE NO.	ITEM	UNIT	TOTAL QUANTITY	80% FED 20% STATE	80% FED 20% STATE SN. 101-2051	80% FED 20% STATE SN. 101-2052	80% FED 20% STATE SN. 101-2004	80% FED 20% STATE	80% FED 20% STATE	80% FED 10% COUNTY 10% VILLAGE	75% STATE 25% VILLAGE	100% VILLAGE	100% FPD	100% RRWRD	100% NPPWD
				ROADWAY 0003 URBAN	BOX CULVERT 0040 URBAN	BOX CULVERT 0040 URBAN	BOX CULVERT 0040 URBAN	RET WALL 0040 URBAN	TRAFF SIGNALS 0021 URBAN	TRAFF SIGNALS 0021 URBAN	TRAFF SIGNALS 0021 URBAN	ROADWAY 0021 URBAN	TRAFF SIGNALS 0021 URBAN	UTILITY 0043 URBAN	UTILITY 0043 URBAN
70400100	TEMPORARY CONCRETE BARRIER	FOOT	3,075.0	3,075.0											
70400200	RELOCATE TEMPORARY CONCRETE BARRIER	FOOT	8,712.5	8,712.5											
72000100	SIGN PANEL - TYPE 1	SQ FT	91						81	10					
78008200	POLYUREA PAVEMENT MARKING TYPE I - LETTERS AND SYMBOLS	SQ FT	2,813.2	2,813.2											
78008210	POLYUREA PAVEMENT MARKING TYPE I - LINE 4"	FOOT	26,060	26,060											
78008230	POLYUREA PAVEMENT MARKING TYPE I - LINE 6"	FOOT	3,212	3,212											
78008240	POLYUREA PAVEMENT MARKING TYPE I - LINE 8"	FOOT	17,495	17,495											
78008250	POLYUREA PAVEMENT MARKING TYPE I - LINE 12"	FOOT	2,551	2,551											
78008270	POLYUREA PAVEMENT MARKING TYPE I - LINE 24"	FOOT	1,269	1,269											
78100100	RAISED REFLECTIVE PAVEMENT MARKER	EACH	793	793											
78200410	GUARDRAIL MARKERS, TYPE A	EACH	26	26											
78201000	TERMINAL MARKER - DIRECT APPLIED	EACH	2	2											
78300100	PAVEMENT MARKING REMOVAL	SQ FT	3,955	3,955											
81012500	CONDUIT IN TRENCH, 1 1/2" DIA., PVC	FOOT	96						79	17					
81012700	CONDUIT IN TRENCH, 2 1/2" DIA., PVC	FOOT	1,517						1474	43					
81013000	CONDUIT IN TRENCH, 4" DIA., PVC	FOOT	406						125	281					
81018600	CONDUIT PUSHED, 2 1/2" DIA., GALVANIZED STEEL	FOOT	398						398						
81018900	CONDUIT PUSHED, 4" DIA., GALVANIZED STEEL	FOOT	2,082						1948	134					
81400100	HANDHOLE	EACH	32						29	3					
81400300	DOUBLE HANDHOLE	EACH	4						3	1					
81702110	ELECTRIC CABLE IN CONDUIT, 600V (XLP-TYPE USE) 1/C NO. 10	FOOT	7,936						6,066	1,870					
81900200	TRENCH AND BACKFILL FOR ELECTRICAL WORK	FOOT	2,019						1678	341					
82102400	LUMINAIRE, SODIUM VAPOR, HORIZONTAL MOUNT, 400 WATT	EACH	4						12	4					
82102250	LUMINAIRE, SODIUM VAPOR, HORIZONTAL MOUNT, 250 WATT	EACH	12												
85700300	FULL-ACTUATED CONTROLLER AND TYPE V CABINET	EACH	4						3	1					
86000100	MASTER CONTROLLER	EACH	1						1						
87100110	FIBER OPTIC CABLE IN CONDUIT, NO. 62.5/125, 6F	FOOT	1,891						1,891						
87301225	ELECTRIC CABLE IN CONDUIT, SIGNAL NO. 14 3C	FOOT	4,455						3,497	958					
87301245	ELECTRIC CABLE IN CONDUIT, SIGNAL NO. 14 5C	FOOT	21,263						19,127	2,136					
87301255	ELECTRIC CABLE IN CONDUIT, SIGNAL NO. 14 7C	FOOT	2,402						1,414	988					

SUMMARY OF QUANTITIES

CODE NO.	ITEM	UNIT	TOTAL QUANTITY	CONSTRUCTION CODE													
				80% FED 20% STATE	80% FED 20% STATE SN. 101-2051	80% FED 20% STATE SN. 101-2052	80% FED 20% STATE SN. 101-2004	80% FED 20% STATE	80% FED 20% STATE	80% FED 10% COUNTY 10% VILLAGE	75% STATE 25% VILLAGE	100% VILLAGE	100% FPD	100% RRWRD	100% NPPWD		
				ROADWAY 0003 URBAN	BOX CULVERT 0040 URBAN	BOX CULVERT 0040 URBAN	BOX CULVERT 0040 URBAN	RET WALL 0040 URBAN	TRAFF SIGNALS 0021 URBAN	TRAFF SIGNALS 0021 URBAN	TRAFF SIGNALS 0021 URBAN	ROADWAY 0021 URBAN	TRAFF SIGNALS 0021 URBAN	UTILITY 0043 URBAN	UTILITY 0043 URBAN		
* 87301295	ELECTRIC CABLE IN CONDUIT, SIGNAL NO. 20 3C	FOOT	4,455							3497	958						
* 87301815	ELECTRIC CABLE IN CONDUIT, SERVICE, NO. 6 3 C	FOOT	96							79	17						
* 87301900	ELECTRIC CABLE IN CONDUIT, EQUIPMENT GROUNDING CONDUCTOR, NO. 6 1C	FOOT	4,518							3,894	624						
* 87800100	CONCRETE FOUNDATION, TYPE A	FOOT	36							36							
* 87800200	CONCRETE FOUNDATION, TYPE D	FOOT	12							9	3						
* 87800400	CONCRETE FOUNDATION, TYPE E 30-INCH DIAMETER	FOOT	10							10							
* 87800415	CONCRETE FOUNDATION, TYPE E 36-INCH DIAMETER	FOOT	184							162	22						
* 87800420	CONCRETE FOUNDATION, TYPE E 42-INCH DIAMETER	FOOT	67							21	46						
* 88040070	SIGNAL HEAD, POLYCARBONATE, LED, 1-FACE, 3-SECTION, BRACKET MOUNTED	EACH	35							31	4						
* 88040090	SIGNAL HEAD, POLYCARBONATE, LED, 1-FACE, 3-SECTION, MAST ARM MOUNTED	EACH	51							45	6						
* 88040120	SIGNAL HEAD, POLYCARBONATE, LED, 1-FACE, 4-SECTION, MAST ARM MOUNTED	EACH	2								2						
* 88040150	SIGNAL HEAD, POLYCARBONATE, LED, 1-FACE, 5-SECTION, BRACKET MOUNTED	EACH	2							2							
* 88040160	SIGNAL HEAD, POLYCARBONATE, LED, 1-FACE, 5-SECTION, MAST ARM MOUNTED	EACH	4							2	2						
* 88200100	TRAFFIC SIGNAL BACKPLATE	EACH	57							47	10						
* 89000100	TEMPORARY TRAFFIC SIGNAL INSTALLATION	EACH	4							4							
* 89000105	TEMPORARY TRAFFIC SIGNAL INSTALLATION (SPECIAL)	EACH	1							1							
* 89501300	RELOCATE EXISTING MAST ARM ASSEMBLY AND POLE	EACH	1							1							
* 89502375	REMOVE EXISTING TRAFFIC SIGNAL EQUIPMENT	EACH	4							4							
* 89502380	REMOVE EXISTING HANDHOLE	EACH	23							23							
* 89502382	REMOVE EXISTING DOUBLE HANDHOLE	EACH	3							3							
* 89502385	REMOVE EXISTING CONCRETE FOUNDATION	EACH	24							24							
** Z0005300	BOX CULVERTS TO BE CLEANED	EACH	1	1													
Z0007601	BUILDING REMOVAL NO. 1	LSUM	1	1													
Z0007602	BUILDING REMOVAL NO. 2	LSUM	1	1													
Z0007603	BUILDING REMOVAL NO. 3	LSUM	1	1													
Z0013302	SEGMENTAL CONCRETE BLOCK WALL	SQ FT	9,452.5						9,452.5								
Z0013798	CONSTRUCTION LAYOUT	LSUM	1	1													
** Z0014700	CULVERT TO BE CLEANED	EACH	3	3													
Z0019500	DRYWELL	EACH	2	2													
Z0022800	FENCE REMOVAL	FOOT	252	252													

* SPECIALTY ITEMS ** NON-PARTICIPATING ITEMS (100% STATE)

SUMMARY OF QUANTITIES

CODE NO.	ITEM	UNIT	TOTAL QUANTITY	CONSTRUCTION CODE														
				80% FED 20% STATE	80% FED 20% STATE SN. 101-2051	80% FED 20% STATE SN. 101-2052	80% FED 20% STATE SN. 101-2004	80% FED 20% STATE	80% FED 20% STATE	80% FED 10% COUNTY 10% VILLAGE	75% STATE 25% VILLAGE	100% VILLAGE	100% FPD	100% RRWRD	100% NPPWD			
				ROADWAY 0003 URBAN	BOX CULVERT 0040 URBAN	BOX CULVERT 0040 URBAN	BOX CULVERT 0040 URBAN	RET WALL 0040 URBAN	TRAFF SIGNALS 0021 URBAN	TRAFF SIGNALS 0021 URBAN	TRAFF SIGNALS 0021 URBAN	ROADWAY 0021 URBAN	TRAFF SIGNALS 0021 URBAN	UTILITY 0043 URBAN	UTILITY 0043 URBAN			
Z0024476	FLEXIBLE DELINEATOR MAINTENANCE	EACH	8	8														
Z0025500	FURNISHING AND INSTALLING PROPERTY MARKERS	EACH	88	88														
Z0026346	NIGHTTIME WORK ZONE LIGHTING	LSUM	1	1														
Z0026407	TEMPORARY SHEET PILING	SQ FT	1,521	1,521														
Z0028415	GEOTECHNICAL REINFORCEMENT	SQ YD	81,692	81,692														
Z0030250	IMPACT ATTENUATORS, TEMPORARY (NON- REDIRECTIVE), TEST LEVEL 3	EACH	2	2														
Z0030260	IMPACT ATTENUATORS, TEMPORARY (FULLY REDIRECTIVE, NARROW), TEST LEVEL 3	EACH	3	3														
Z0030280	IMPACT ATTENUATORS, TEMPORARY (SEVERE USE, NARROW), TEST LEVEL 3	EACH	3	3														
Z0030330	IMPACT ATTENUATORS, RELOCATE (FULLY REDIRECTIVE), TEST LEVEL 3	EACH	5	5														
Z0030350	IMPACT ATTENUATORS, RELOCATE (NON- REDIRECTIVE), TEST LEVEL 3	EACH	6	6														
Z0030370	IMPACT ATTENUATORS, RELOCATE (SEVERE USE, NARROW), TEST LEVEL 3	EACH	10	10														
Z0033072	VIDEO VEHICLE DETECTION SYSTEM	EACH	4							3	1							
Z0056648	STORM SEWERS, TYPE 1, WATER MAIN QUALITY PIPE, 12"	FOOT	248	248														
Z0056668	STORM SEWERS, TYPE 2, WATER MAIN QUALITY PIPE, 12"	FOOT	93	93														
Z0056672	STORM SEWERS, TYPE 2, WATER MAIN QUALITY PIPE, 24"	FOOT	103	103														
Z0062456	TEMPORARY PAVEMENT	SQ YD	28,977	28,977														
Z0065753	SLOTTED DRAIN 15" WITH 6" SLOT	FOOT	30	30														
Z0073002	TEMPORARY SOIL RETENTION SYSTEM	SQ FT	1,376		1,376													
X5610700	WATER MAIN REMOVAL	FOOT	125															125
Z0077700	WOOD FENCE TO BE REMOVED AND RE-ERECTED	FOOT	292	292														
A2000114	TREE, ACER X FREEMANII AUTUMN BLAZE (AUTUMN BLAZE FREEMAN MAPLE), 1-3/4" CALIPER, BALLED AND BURLAPPED	EACH	15	15														
A2001714	TREE, ACER SACCHARUM (SUGAR MAPLE), 1-3/4" CALIPER, BALLED AND BURLAPPED	EACH	20	20														
A2006714	TREE, QUERCUS MACROCARPA (BUR OAK), 1-3/4" CALIPER, BALLED AND BURLAPPED	EACH	9	9														
B2002614	TREE, MALUS ADAMS (ADAMS CRABAPPLE), 1-3/4" CALIPER, TREE FORM, BALLED AND BURLAPPED	EACH	15	15														
B2004814	TREE, MALUS SARGENTII (SARGENT CRABAPPLE), 1-3/4" CALIPER, TREE FORM, BALLED AND BURLAPPED	EACH	17	17														
XZ127900	RETAINING WALL REMOVAL	FOOT	1,450	1,450														
X0322936	REMOVE EXISTING FLARED END SECTION	EACH	3	3														
X5610748	WATER MAIN LINE STOP 8"	EACH	1															1
X0324102	EMERGENCY VEHICLE SIGNAL CONTROL SYSTEM	EACH	4											4				
X5610006	DUCTILE IRON WATER MAIN FITTINGS, MECHANICAL JOINT 8" X 6" HYDRANT TEE	EACH	1															1

SUMMARY OF QUANTITIES

CODE NO.	ITEM	UNIT	TOTAL QUANTITY	CONSTRUCTION CODE																		
				80% FED 20% STATE	80% FED 20% STATE SN. 101-2051	80% FED 20% STATE SN. 101-2052	80% FED 20% STATE SN. 101-2004	80% FED 20% STATE	80% FED 20% STATE	80% FED 10% COUNTY 10% VILLAGE	75% STATE 25% VILLAGE	100% VILLAGE	100% FPD	100% RRWRD	100% NPPWD							
				ROADWAY 0003 URBAN	BOX CULVERT 0040 URBAN	BOX CULVERT 0040 URBAN	BOX CULVERT 0040 URBAN	RET WALL 0040 URBAN	TRAFF SIGNALS 0021 URBAN	TRAFF SIGNALS 0021 URBAN	TRAFF SIGNALS 0021 URBAN	ROADWAY 0021 URBAN	TRAFF SIGNALS 0021 URBAN	UTILITY 0043 URBAN	UTILITY 0043 URBAN							
X0327068	PAVEMENT COLOR AND TEXTURE (SPECIAL)	SQ YD	2,321	2,321																		
X4201000	HIGH-EARLY-STRENGTH PORTLAND CEMENT CONCRETE PAVEMENT 9 1/2" (JOINTED)	SQ YD	1,238	1,238																		
X4400110	TEMPORARY PAVEMENT REMOVAL	SQ YD	28,315	28,315																		
X4402805	ISLAND REMOVAL	SQ FT	4,333	4,333																		
X4404000	PARKING LOT PAVEMENT REMOVAL	SQ YD	2,654	2,654																		
X6022820	MANHOLES, SANITARY, 5'-DIAMETER, TYPE 1 FRAME, CLOSED LID	EACH	1																			1
X6024246	INLETS, SPECIAL, NO. 3	EACH	5	5																		
X6024250	INLETS, SPECIAL, NO. 5	EACH	58	58																		
X6024254	INLETS, SPECIAL, NO. 7	EACH	1	1																		
X6024256	INLETS, SPECIAL, NO. 8	EACH	1	1																		
X6026050	SANITARY MANHOLES TO BE ADJUSTED	EACH	8																			8
X6026051	SANITARY MANHOLES TO BE RECONSTRUCTED	EACH	3																			3
X7010216	TRAFFIC CONTROL AND PROTECTION, (SPECIAL)	LSUM	1	1																		
* X7200105	SIGN PANEL - TYPE 1 (SPECIAL)	SQ FT	150								135	15										
* X7200205	SIGN PANEL - TYPE 2 (SPECIAL)	SQ FT	52								26	26										
* X8050095	SERVICE INSTALLATION (SPECIAL)	EACH	4								3	1										
* X8250505	LIGHTING CONTROLLER, SPECIAL	EACH	4								3	1										
* X8410102	TEMPORARY LIGHTING SYSTEM	LSUM	1	1																		
* X8770125	STEEL COMBINATION MAST ARM ASSEMBLY AND POLE 28 FT. (SPECIAL)	EACH	1																			1
* X8770134	STEEL COMBINATION MAST ARM ASSEMBLY AND POLE 34 FT. (SPECIAL)	EACH	1																			1
* X8770136	STEEL COMBINATION MAST ARM ASSEMBLY AND POLE 36 FT. (SPECIAL)	EACH	1																			1
* X8770142	STEEL COMBINATION MAST ARM ASSEMBLY AND POLE 50 FT. (SPECIAL)	EACH	1																			1
* X8770151	STEEL COMBINATION MAST ARM ASSEMBLY AND POLE 55 FT. (SPECIAL)	EACH	5																			5
* X8770152	STEEL COMBINATION MAST ARM ASSEMBLY AND POLE 52 FT. (SPECIAL)	EACH	2																			2
* X8770154	STEEL COMBINATION MAST ARM ASSEMBLY AND POLE 54 FT. (SPECIAL)	EACH	1																			1
* X8770156	STEEL COMBINATION MAST ARM ASSEMBLY AND POLE 56 FT. (SPECIAL)	EACH	1																			1
* X8770158	STEEL COMBINATION MAST ARM ASSEMBLY AND POLE 58 FT. (SPECIAL)	EACH	1																			1
* X8770168	STEEL COMBINATION MAST ARM ASSEMBLY AND POLE 68 FT. (SPECIAL)	EACH	1																			1
* X8770240	STEEL COMBINATION MAST ARM WITH DUAL MAST ARMS, 28 FT. AND 55 FT., (SPECIAL)	EACH	1																			1
* X8750005	TRAFFIC SIGNAL POST, 14 FT., (SPECIAL)	EACH	12																			12

EXISTING LEGEND:

- ① HMA OVERLAY, 5.7"
- ② PCC PAVEMENT, 7.6"
- ③ COMBINATION CONCRETE CURB AND GUTTER
- ④ CONCRETE MEDIAN
- ⑤ HMA SHOULDER

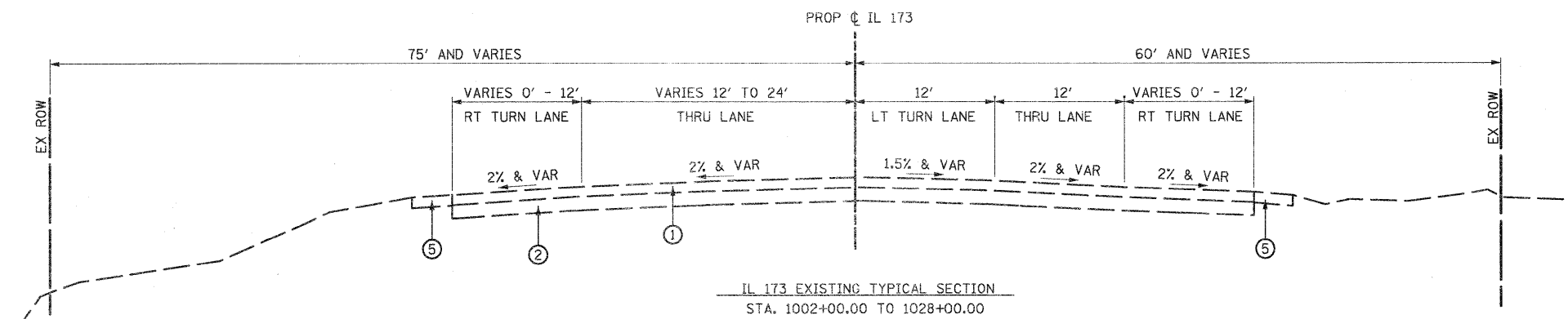
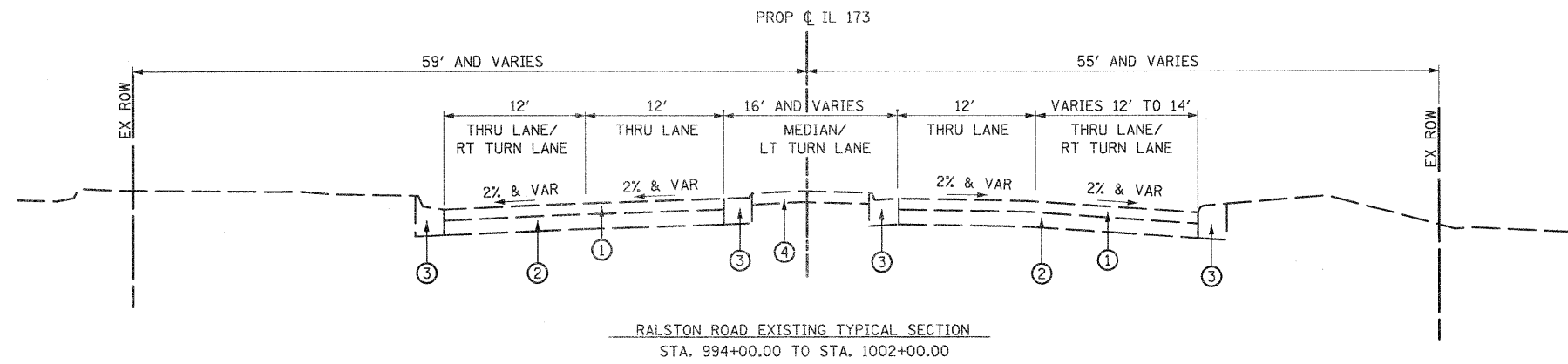
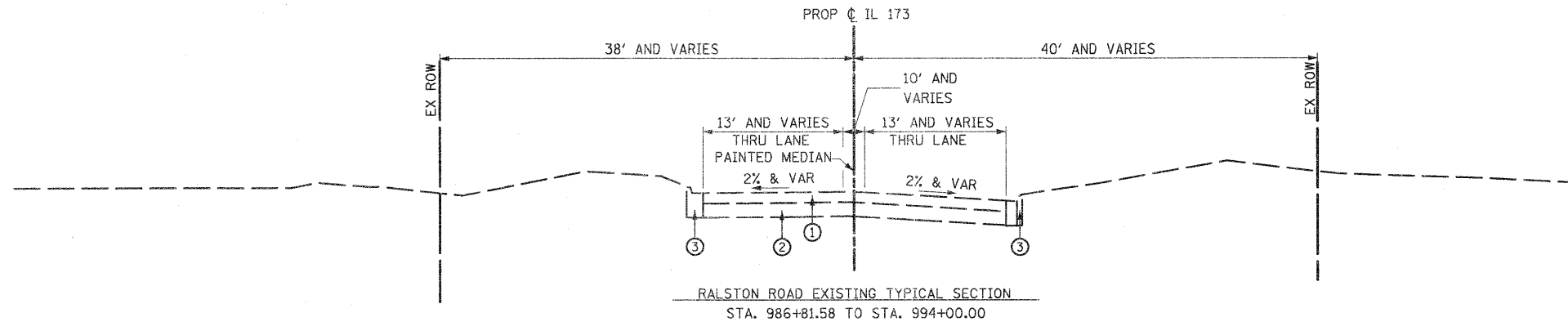

FILE NAME =
D264987-shr-typical-EX01.dgn

USER NAME = 3202000971

DESIGNED - LOM

REVISED -

DRAWN - MD

REVISED -

PLOT SCALE = NTS

CHECKED - PDK

REVISED -

PLOT DATE = 1/18/2011

DATE - 01-19-2011

REVISED -

STATE OF ILLINOIS
DEPARTMENT OF TRANSPORTATION

EXISTING TYPICAL SECTIONS
RALSTON ROAD \ ILLINOIS ROUTE 173

SCALE: NTS SHEET NO. OF SHEETS STA. TO STA.

F.A.P. RTE.	SECTION	COUNTY	TOTAL SHEETS	SHEET NO.
303	129K-1	WINNEBAGO	401	14
CONTRACT NO. 64987				
FED. ROAD DIST. NO. 2 ILLINOIS FED. AID PROJECT				

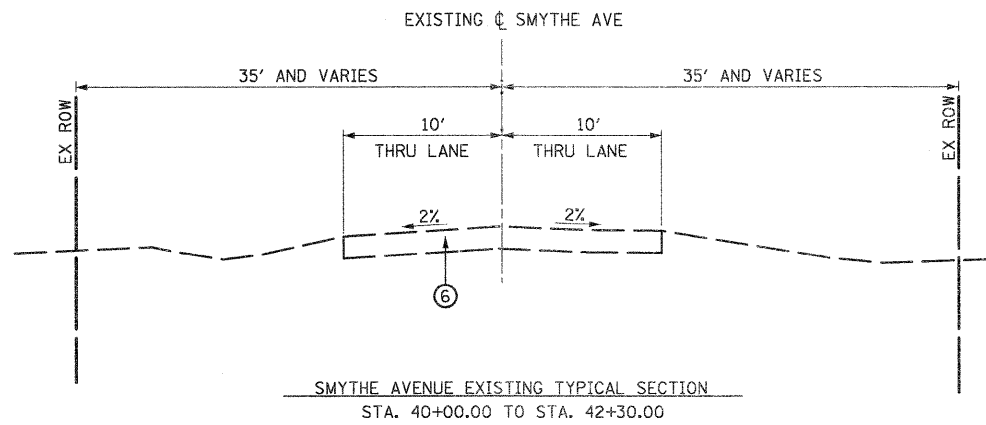

EXISTING LEGEND:

- ① HMA OVERLAY
- ② PCC PAVEMENT
- ③ COMBINATION CONCRETE CURB AND GUTTER
- ④ CONCRETE MEDIAN
- ⑤ HMA SHOULDER
- ⑥ HMA PAVEMENT

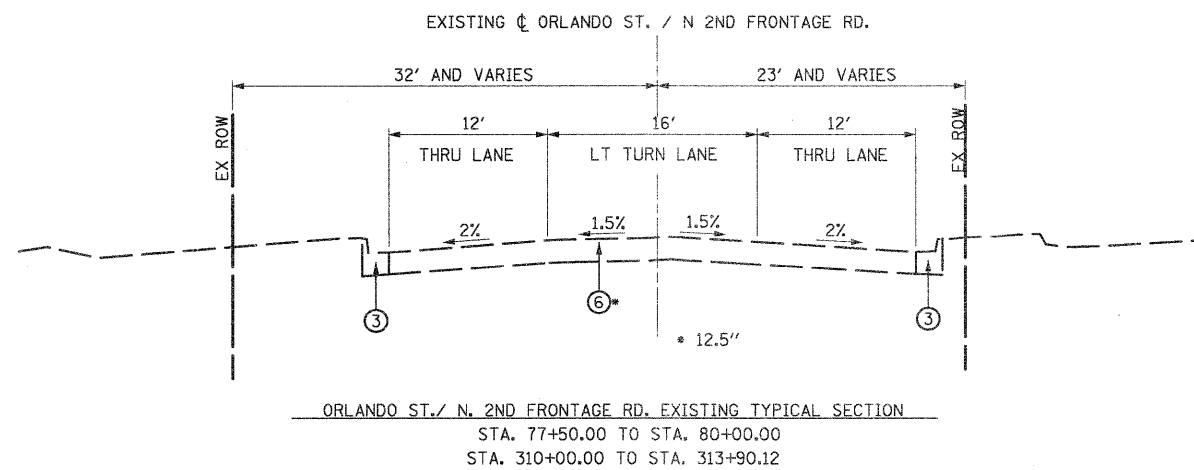
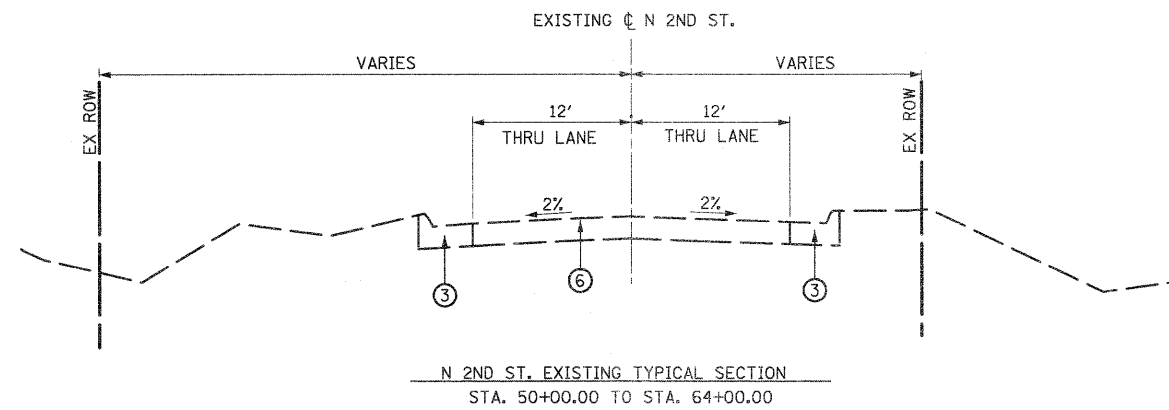

FILE NAME =
D264987-shr-typical-EX02.dgn

USER NAME = 3282090971
PLOT SCALE = NTS
PLOT DATE = 1/18/2011

DESIGNED - LOM
DRAWN - MD
CHECKED - PDK
DATE - 01-19-2011

REVISED -
REVISED -
REVISED -
REVISED -

STATE OF ILLINOIS
DEPARTMENT OF TRANSPORTATION

EXISTING TYPICAL SECTIONS
SMYTHE AVE \ N. 2ND ST \ ORLANDO ST \ N 2ND FRONTAGE RD
SCALE: NTS SHEET NO. OF SHEETS STA. TO STA.

F.A.P. RTE.	SECTION	COUNTY	TOTAL SHEETS	SHEET NO.
303	129K-1	WINNEBAGO	401	15
CONTRACT NO. 64987				
FED. ROAD DIST. NO. 2 ILLINOIS FED. AID PROJECT				

EXISTING LEGEND:

- ① HMA OVERLAY, 5.5"
- ② PCC PAVEMENT, 9"
- ③ COMBINATION CONCRETE CURB AND GUTTER
- ④ CONCRETE MEDIAN
- ⑤ HMA SHOULDER

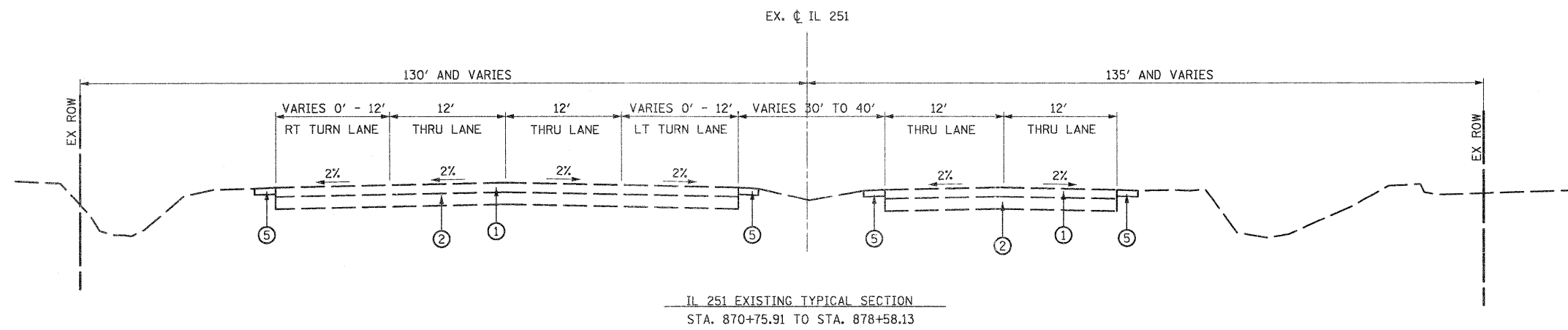
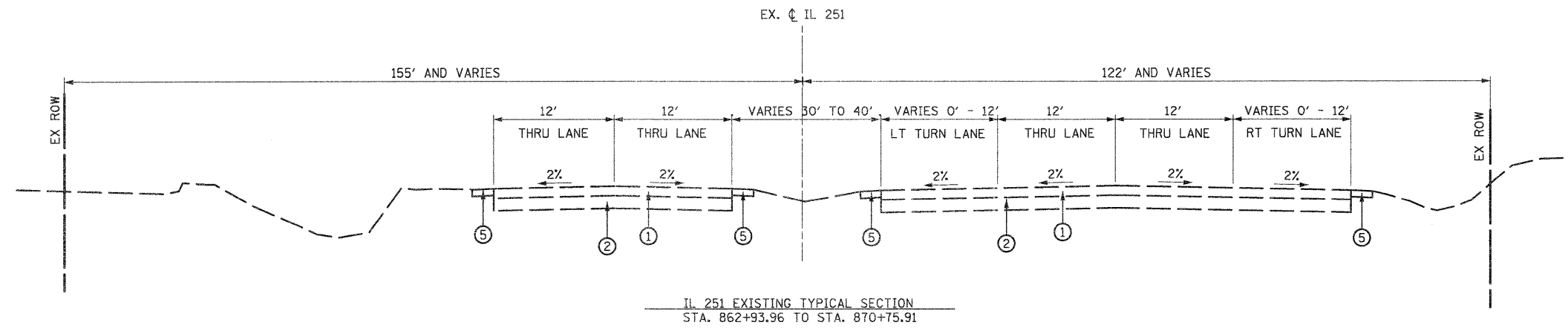

FILE NAME =
0264987-shr-typical-EX03.dgn

USER NAME = 32020909/1
PLOT SCALE = NTS
PLOT DATE = 1/18/2011

DESIGNED - LOM
DRAWN - MD
CHECKED - PDK
DATE - 01-19-2011

REVISED -
REVISED -
REVISED -
REVISED -

**STATE OF ILLINOIS
DEPARTMENT OF TRANSPORTATION**

**EXISTING TYPICAL SECTIONS
ILLINOIS ROUTE 251**

SCALE: NTS SHEET NO. OF SHEETS STA. TO STA.

F.A.P. RTE.	SECTION	COUNTY	TOTAL SHEETS	SHEET NO.
303	129K-1	WINNEBAGO	401	16
CONTRACT NO. 64987				

FED. ROAD DIST. NO. 2 ILLINOIS FED. AID PROJECT

EXISTING LEGEND:

- ① HMA OVERLAY
- ② PCC PAVEMENT
- ③ COMBINATION CONCRETE CURB AND GUTTER
- ④ CONCRETE MEDIAN
- ⑤ HMA SHOULDER

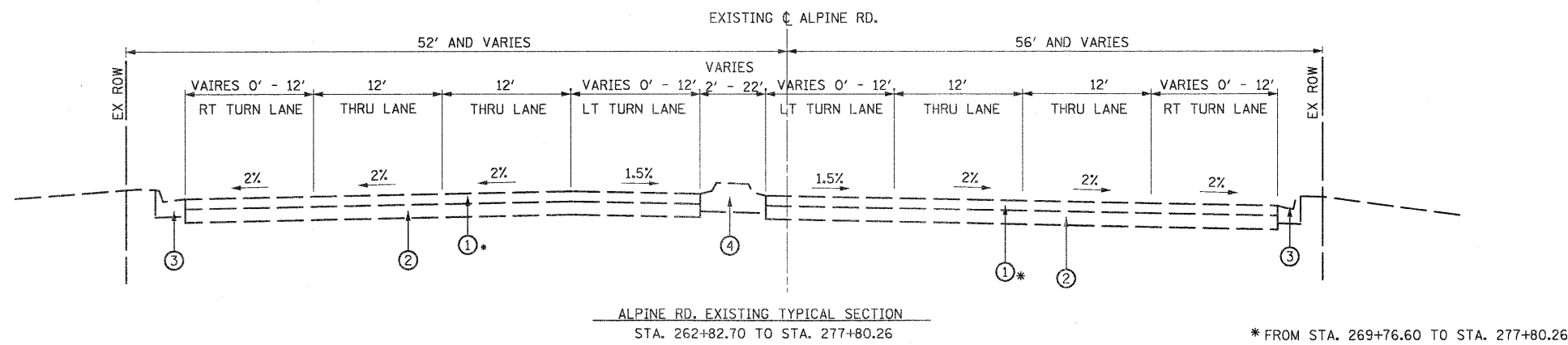
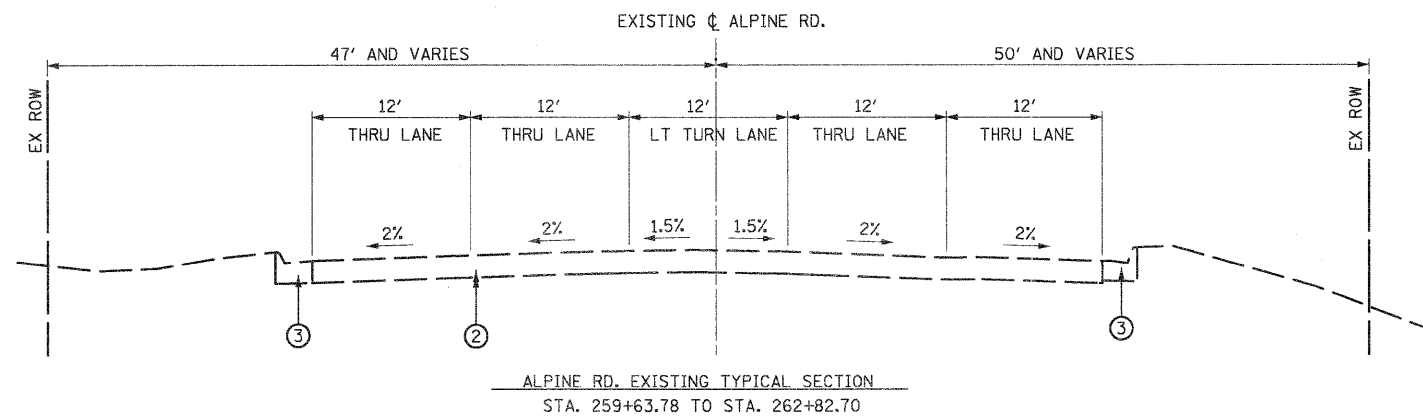

FILE NAME =
D264987-shr-typical-EX04.dgn

USER NAME = 3282290971
PLOT SCALE = NTS
PLOT DATE = 1/18/2011

DESIGNED - LOM
DRAWN - MD
CHECKED - PDK
DATE - 01-19-2011

REVISED -
REVISED -
REVISED -
REVISED -

**STATE OF ILLINOIS
DEPARTMENT OF TRANSPORTATION**

**EXISTING TYPICAL SECTIONS
ALPINE ROAD**

SCALE: NTS SHEET NO. OF SHEETS STA. TO STA.

F.A.P. RTE.	SECTION	COUNTY	TOTAL SHEETS	SHEET NO.
303	129K-1	WINNEBAGO	401	17
CONTRACT NO. 64987				
FED. ROAD DIST. NO. 2 ILLINOIS FED. AID PROJECT				

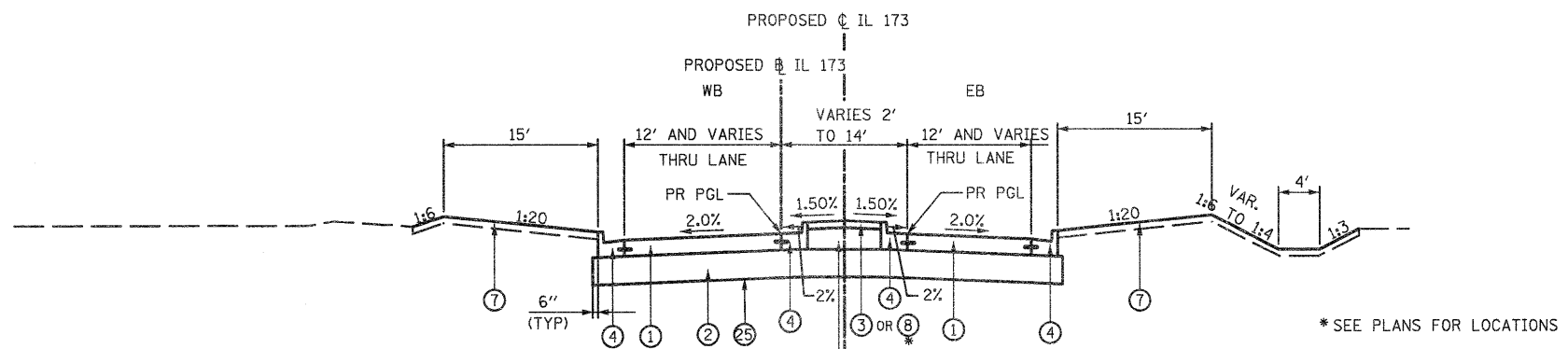

RALSTON ROAD PROPOSED TYPICAL SECTION
STA. 986+81.58 TO STA. 989+30.78

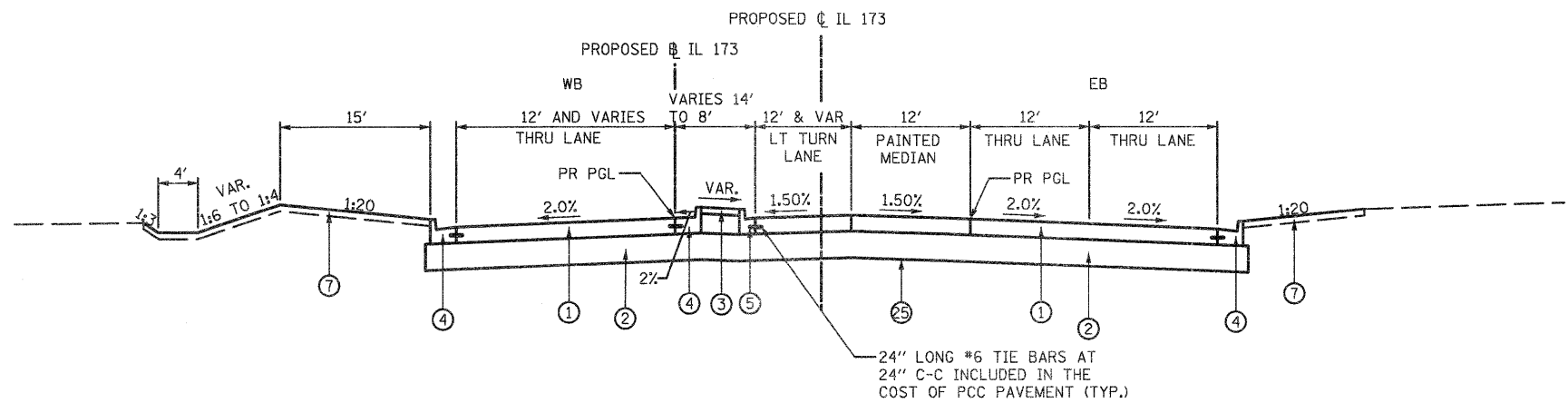

RALSTON ROAD PROPOSED TYPICAL SECTION
STA. 989+30.78 TO STA. 992+94.01

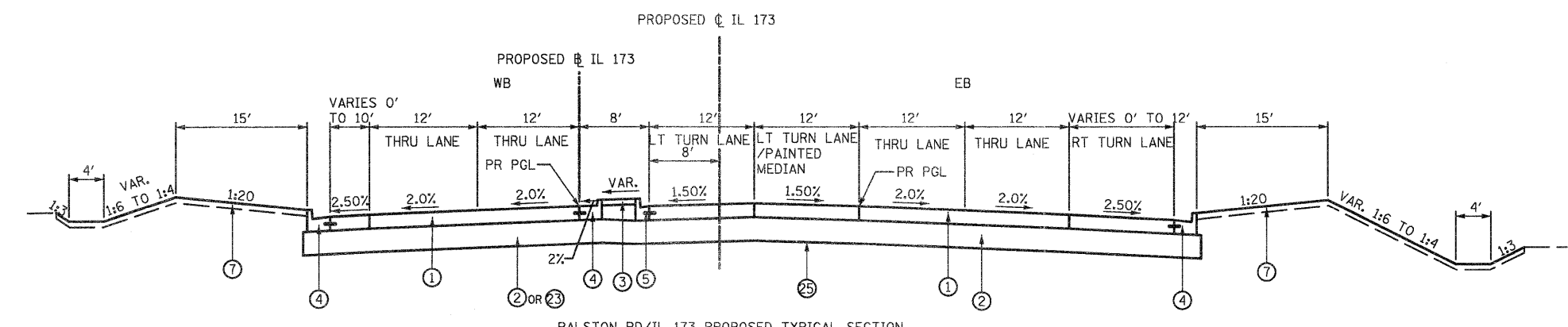

RALSTON RD/IL 173 PROPOSED TYPICAL SECTION

CHANNEL WALLS FROM STA. 1009+60.89 TO STA. 1011+56.29 AND FROM STA. 1017+72.57 TO STA. 1018+47.09, LEFT. SEE DETAILS NEXT SHEET.

NOTE: PROFILE GRADE LINE (PGL) CORRESPONDS TO BASELINE SHOWN ON THE PLANS.

PROPOSED LEGEND:

- ① PORTLAND CEMENT CONCRETE PAVEMENT (JOINTED), SEE TABLE THIS SHEET FOR THICKNESS
- ② SUB-BASE GRANULAR MATERIAL, TYPE A, 12"
- ③ HOT-MIX ASPHALT MEDIAN WITH PAVEMENT COLOR AND TEXTURE (SPECIAL)
- ④ COMBINATION CONCRETE CURB AND GUTTER B-6.24
- ⑤ COMBINATION CONCRETE CURB AND GUTTER B-6.12
- ⑥ PORTLAND CEMENT CONCRETE SHOULDER, 9.5"
- ⑦ TOPSOIL FURNISH AND PLACE, 4"
- ⑧ CORRUGATED MEDIAN
- ⑨ COMBINATION CONCRETE CURB AND GUTTER B-6.18
- ⑩ COMBINATION CONCRETE CURB AND GUTTER B-6.06
- ⑪ CONCRETE MEDIAN, TYPE SB-6.06
- ⑫ 2" POLYMERIZED HOT-MIX ASPHALT SURFACE COURSE, MIX "E" N70
- ⑬ 10.75" POLYMERIZED HOT-MIX ASPHALT BINDER COURSE, IL-19.0, N70
- ⑭ BITUMINOUS MATERIAL (PRIME COAT)
- ⑮ 4.75" HOT-MIX ASPHALT BINDER COURSE, IL-19.0, N50
- ⑯ 6.5" HOT-MIX ASPHALT BINDER COURSE, IL-19.0, N50
- ⑰ #6 TIE BARS (FOR MORE INFO SEE GENERAL NOTES SHEETS)
- ⑱ PORTLAND CEMENT CONCRETE BASE COURSE, 10"
- ⑲ HOT-MIX ASPHALT SURFACE REMOVAL, 2.25"
- ⑳ 1.5" POLYMERIZED HOT-MIX ASPHALT SURFACE COURSE, MIX "E", N70
- ㉑ 0.75" POLYMERIZED LEVELING BINDER (MACHINE METHOD), N70
- ㉒ 2" HOT-MIX ASPHALT SURFACE COURSE, MIX "C" N50
- ㉓ SUB-BASE GRANULAR MATERIAL, TYPE A, 21" (STA. 993+00 TO STA. 1002+50 AND STA. 1021+50 TO STA. 1022+20.19)
- ㉔ POLYMERIZED BITUMINOUS MATERIAL (PRIME COAT)
- ㉕ GEOTECHNICAL REINFORCEMENT

PCC PAVEMENT THICKNESS TABLE

ROADWAY	THICKNESS
RALSTON RD /IL 173	9.5"
IL 251	9.5"
ALPINE RD	9.5"
ORLANDO ST/N 2ND FRONTAGE RD	8.25"

IL 173 / RALSTON PCC PAVEMENT

STRUCTURAL DESIGN TRAFFIC:	YEAR 2021	
PV= 39655	SU= 1035	MU= 665
ROAD/STREET CLASSIFICATION:	CLASS I	
P= 32%	S= 45%	M= 45%
TRAFFIC FACTOR:	ACTUAL TF= 6.03	AC TYPE= N/A
	MINIMUM TF=	
PG GRADE: BINDER=	N/A	SURFACE= N/A
SUBGRADE SUPPORT RATING:		
SSR= POOR	(STA. 986+81.58 TO 1022+20.19)	
SSR=	(STA. TO TO)	

FILE NAME =
D264987-sh-typical-PR01.dgn

USER NAME = 3282870971
PLOT SCALE = NTS
PLOT DATE = 1/18/2011

DESIGNED - LOM
DRAWN - MD
CHECKED - PDK
DATE - 01-19-2011

REVISED -
REVISED -
REVISED -
REVISED -

STATE OF ILLINOIS
DEPARTMENT OF TRANSPORTATION

PROPOSED TYPICAL SECTIONS
RALSTON ROAD \ ILLINOIS ROUTE 173

SCALE: NTS SHEET NO. OF SHEETS STA. TO STA.

F.A.P. RTE.	SECTION	COUNTY	TOTAL SHEETS	SHEET NO.
303	129K-1	WINNEBAGO	401	18

CONTRACT NO. 64987
FED. ROAD DIST. NO. 2 ILLINOIS FED. AID PROJECT

NOTE: PROFILE GRADE LINE (PGL) CORRESPONDS TO BASELINE SHOWN ON THE PLANS.

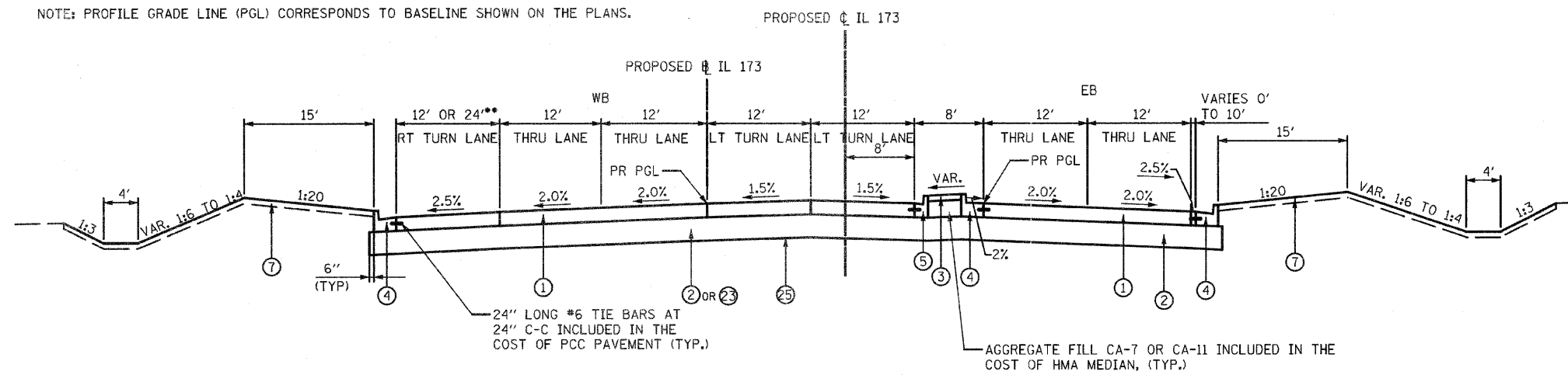

CHANNEL WALL FROM STA. 1012+85.74 TO STA. 1014+55.65, LEFT. SEE SINGLE CHANNEL WALL DETAIL THIS SHEET.

RALSTON RD/IL 173 PROPOSED TYPICAL SECTION
 STA. 994+52.77 TO STA. 996+29.85
 STA. 1002+68.09 TO STA. 1006+48.89
 STA. 1012+26.19 TO STA. 1014+55.65

** DUAL RT TURN LANE AT IL 251

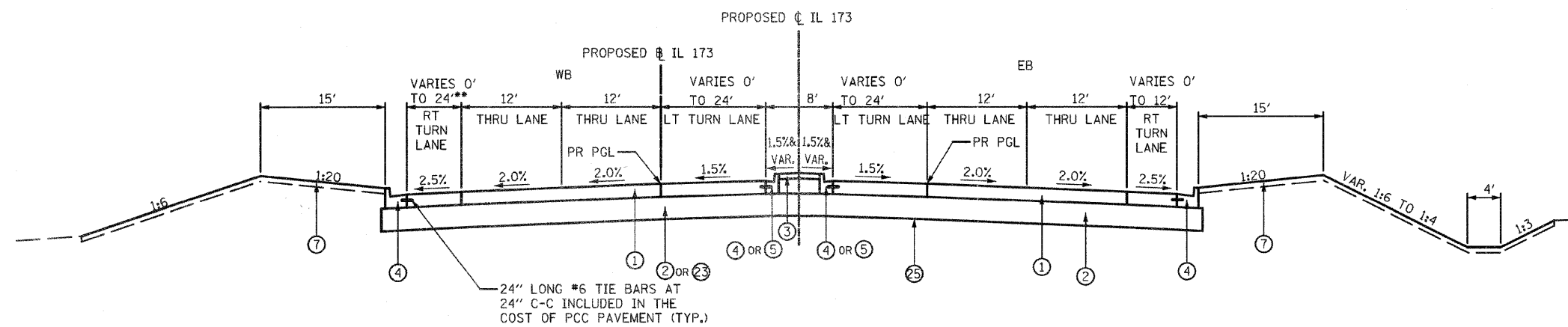

CHANNEL WALLS FROM STA. 1009+48.32 TO STA. 1009+60.89 AND FROM STA. 1014+55.65 TO STA. 1017+72.57, LEFT. SEE DETAILS THIS SHEET.

RALSTON RD/IL 173 PROPOSED TYPICAL SECTION
 STA. 996+29.85 TO STA. 999+41.85
 STA. 1006+48.89 TO STA. 1009+60.89
 STA. 1014+55.65 TO STA. 1017+72.57

PROPOSED LEGEND:

- ① PORTLAND CEMENT CONCRETE PAVEMENT (JOINTED), SEE TABLE THIS SHEET FOR THICKNESS
- ② SUB-BASE GRANULAR MATERIAL, TYPE A, 12"
- ③ HOT-MIX ASPHALT MEDIAN WITH PAVEMENT COLOR AND TEXTURE (SPECIAL)
- ④ COMBINATION CONCRETE CURB AND GUTTER B-6.24
- ⑤ COMBINATION CONCRETE CURB AND GUTTER B-6.12
- ⑥ PORTLAND CEMENT CONCRETE SHOULDER, 9.5"
- ⑦ TOPSOIL FURNISH AND PLACE, 4"
- ⑧ CORRUGATED MEDIAN
- ⑨ COMBINATION CONCRETE CURB AND GUTTER B-6.18
- ⑩ COMBINATION CONCRETE CURB AND GUTTER B-6.06
- ⑪ CONCRETE MEDIAN, TYPE SB-6.06
- ⑫ 2" POLYMERIZED HOT-MIX ASPHALT SURFACE COURSE, MIX "E" N70
- ⑬ 10.75" POLYMERIZED HOT-MIX ASPHALT BINDER COURSE, IL-19.0, N70
- ⑭ BITUMINOUS MATERIAL (PRIME COAT)
- ⑮ 4.75" HOT-MIX ASPHALT BINDER COURSE, IL-19.0, N50
- ⑯ 6.5" HOT-MIX ASPHALT BINDER COURSE, IL-19.0, N50
- ⑰ #6 TIE BARS (FOR MORE INFO SEE GENERAL NOTES SHEETS)
- ⑱ PORTLAND CEMENT CONCRETE BASE COURSE, 10"
- ⑲ HOT-MIX ASPHALT SURFACE REMOVAL, 2.25"
- ⑳ 1.5" POLYMERIZED HOT-MIX ASPHALT SURFACE COURSE, MIX "E", N70
- ㉑ 0.75" POLYMERIZED LEVELING BINDER (MACHINE METHOD), N70
- ㉒ 2" HOT-MIX ASPHALT SURFACE COURSE, MIX "C" N50
- ㉓ SUB-BASE GRANULAR MATERIAL, TYPE A, 21" (STA. 993+00 TO STA. 1002+50 AND STA. 1021+50 TO STA. 1022+20.19)
- ㉔ POLYMERIZED BITUMINOUS MATERIAL (PRIME COAT)
- ㉕ GEOTECHNICAL REINFORCEMENT

PCC PAVEMENT THICKNESS TABLE

ROADWAY	THICKNESS
RALSTON RD /IL 173	9.5"
IL 251	9.5"
ALPINE RD	9.5"
ORLANDO ST/N 2ND FRONTAGE RD	8.25"

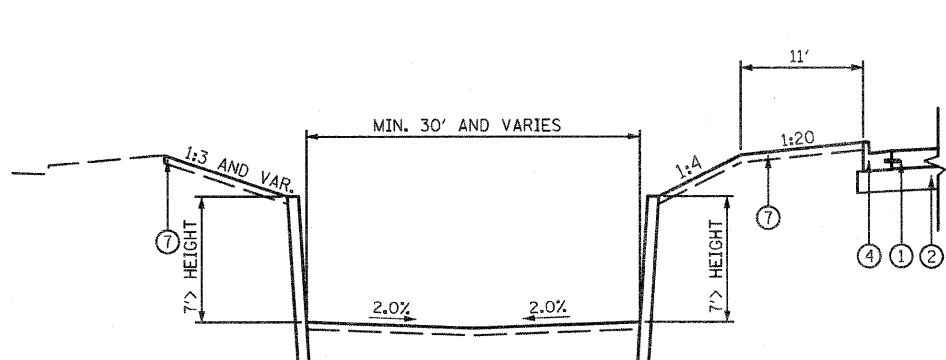

DOUBLE CHANNEL WALL
 STA. 1009+48.32 TO STA. 1011+56.29, LEFT.

NOTE:
 FOR MORE CHANNEL WALLS INFO SEE CHANNEL WALLS DETAILS SHEETS.

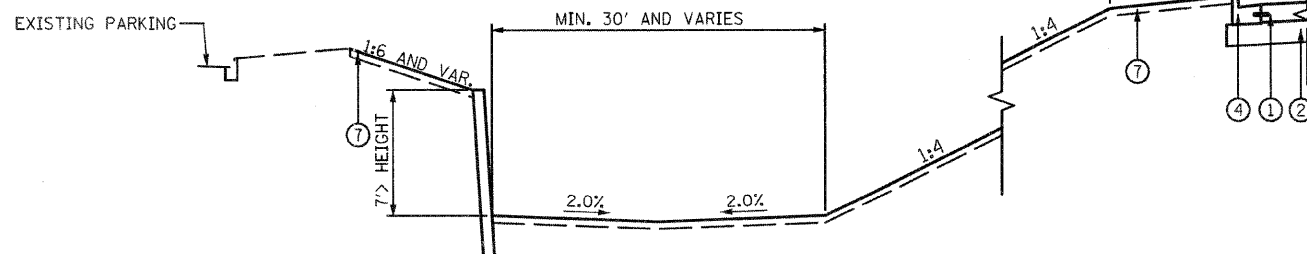

SINGLE CHANNEL WALL
 STA. 1012+85.74 TO STA. 1018+43.09, LEFT.

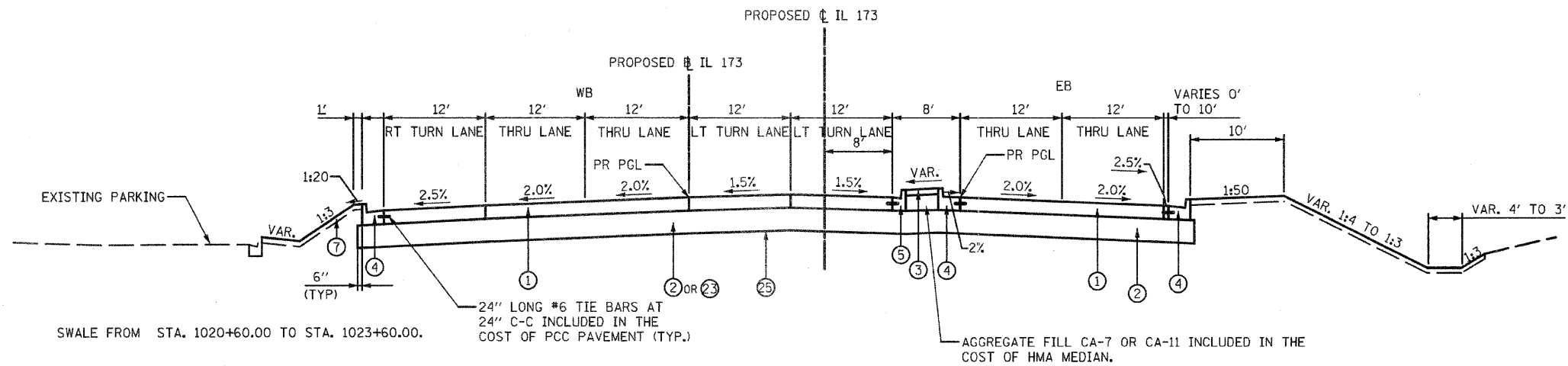

RALSTON RD/IL 173 PROPOSED TYPICAL SECTION
STA. 1019+59.17 TO STA. 1022+20.19

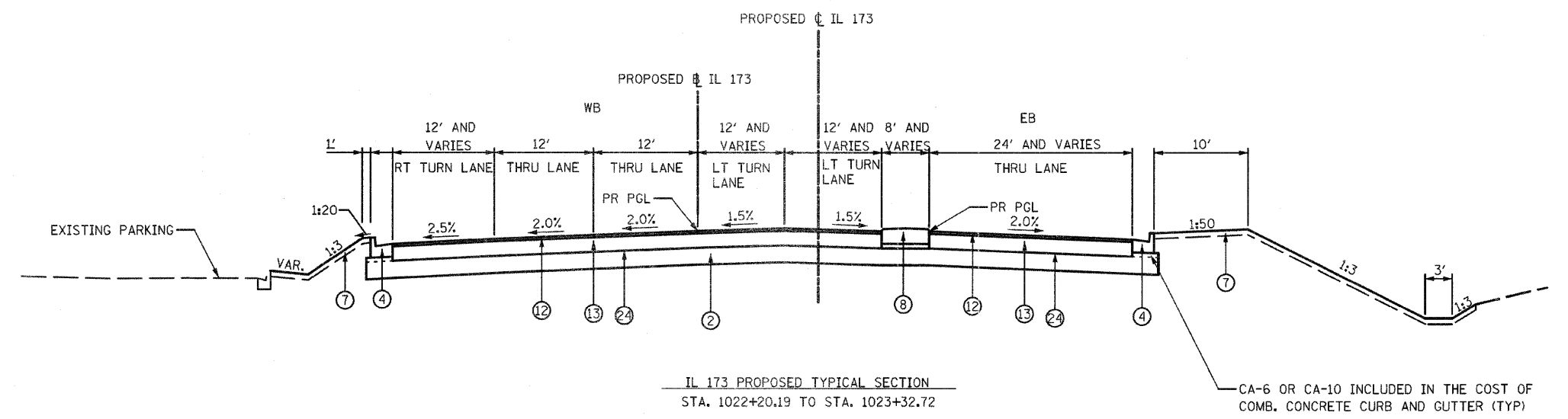

IL 173 PROPOSED TYPICAL SECTION
STA. 1022+20.19 TO STA. 1023+32.72

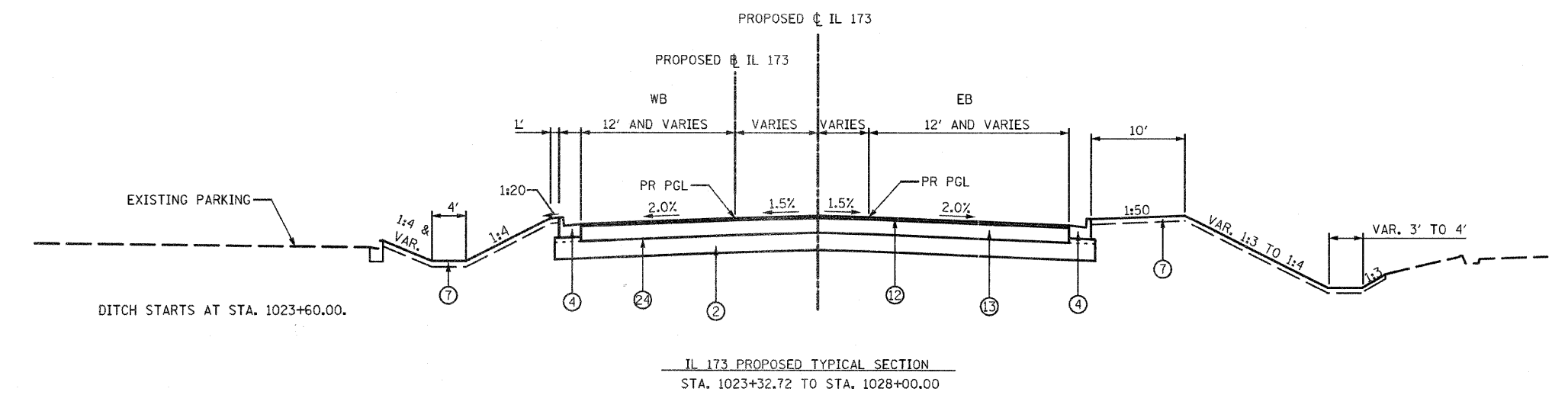

IL 173 PROPOSED TYPICAL SECTION
STA. 1023+32.72 TO STA. 1028+00.00

NOTES:
1. SEE GENERAL NOTES SHEET FOR HMA PAVEMENT REQUIREMENTS.
2. PROFILE GRADE LINE (PGL) CORRESPONDS TO BASELINE SHOWN ON THE PLANS.

PROPOSED LEGEND:

- ① PORTLAND CEMENT CONCRETE PAVEMENT (JOINTED), SEE TABLE THIS SHEET FOR THICKNESS
- ② SUB-BASE GRANULAR MATERIAL, TYPE A, 12"
- ③ HOT-MIX ASPHALT MEDIAN WITH PAVEMENT COLOR AND TEXTURE (SPECIAL)
- ④ COMBINATION CONCRETE CURB AND GUTTER B-6.24
- ⑤ COMBINATION CONCRETE CURB AND GUTTER B-6.12
- ⑥ PORTLAND CEMENT CONCRETE SHOULDER, 9.5"
- ⑦ TOPSOIL FURNISH AND PLACE, 4"
- ⑧ CORRUGATED MEDIAN
- ⑨ COMBINATION CONCRETE CURB AND GUTTER B-6.18
- ⑩ COMBINATION CONCRETE CURB AND GUTTER B-6.06
- ⑪ CONCRETE MEDIAN, TYPE SB-6.06
- ⑫ 2" POLYMERIZED HOT-MIX ASPHALT SURFACE COURSE, MIX "E" N70
- ⑬ 10.75" POLYMERIZED HOT-MIX ASPHALT BINDER COURSE, IL-19.0, N70
- ⑭ BITUMINOUS MATERIAL (PRIME COAT)
- ⑮ 4.75" HOT-MIX ASPHALT BINDER COURSE, IL-19.0, N50
- ⑯ 6.5" HOT-MIX ASPHALT BINDER COURSE, IL-19.0, N50
- ⑰ #6 TIE BARS (FOR MORE INFO SEE GENERAL NOTES SHEETS)
- ⑱ PORTLAND CEMENT CONCRETE BASE COURSE, 10"
- ⑲ HOT-MIX ASPHALT SURFACE REMOVAL, 2.25"
- ⑳ 1.5" POLYMERIZED HOT-MIX ASPHALT SURFACE COURSE, MIX "E", N70
- ㉑ 0.75" POLYMERIZED LEVELING BINDER (MACHINE METHOD), N70
- ㉒ 2" HOT-MIX ASPHALT SURFACE COURSE, MIX "C" N50
- ㉓ SUB-BASE GRANULAR MATERIAL, TYPE A, 21" (STA. 993+00 TO STA. 1002+50 AND STA. 1021+50 TO STA. 1022+20.19)
- ㉔ POLYMERIZED BITUMINOUS MATERIAL (PRIME COAT)
- ㉕ GEOTECHNICAL REINFORCEMENT

PCC PAVEMENT THICKNESS TABLE

ROADWAY	THICKNESS
IL 173	9.5"
IL 251	9.5"
ALPINE RD	9.5"
ORLANDO ST/N 2ND FRONTAGE RD	8.25"

IL 173

FLEXIBLE PAVEMENT

STRUCTURAL DESIGN TRAFFIC:	YEAR 2021	
PV= 49603	SU= 460	MU= 333
ROAD/STREET CLASSIFICATION:	CLASS I	
P= 32%	S= 45%	M= 45%
TRAFFIC FACTOR:	ACTUAL TF= 4.27	AC TYPE= 20
	MINIMUM TF=	
PG GRADE: BINDER=	PG 64-22	SURFACE= PG 64-22
SUBGRADE SUPPORT RATING:		
SSR= POOR	(STA. 1022+20.19 TO 1028+00.00)	
SSR=	(STA. TO)	

PROPOSED LEGEND:

- ① PORTLAND CEMENT CONCRETE PAVEMENT (JOINTED), SEE TABLE THIS SHEET FOR THICKNESS
- ② SUB-BASE GRANULAR MATERIAL, TYPE A, 12"
- ③ HOT-MIX ASPHALT MEDIAN WITH PAVEMENT COLOR AND TEXTURE (SPECIAL)
- ④ COMBINATION CONCRETE CURB AND GUTTER B-6.24
- ⑤ COMBINATION CONCRETE CURB AND GUTTER B-6.12
- ⑥ PORTLAND CEMENT CONCRETE SHOULDER, 9.5"
- ⑦ TOPSOIL FURNISH AND PLACE, 4"
- ⑧ CORRUGATED MEDIAN
- ⑨ COMBINATION CONCRETE CURB AND GUTTER B-6.18
- ⑩ COMBINATION CONCRETE CURB AND GUTTER B-6.06
- ⑪ CONCRETE MEDIAN, TYPE SB-6.06
- ⑫ 2" POLYMERIZED HOT-MIX ASPHALT SURFACE COURSE, MIX "E" N70
- ⑬ 10.75" POLYMERIZED HOT-MIX ASPHALT BINDER COURSE, IL-19.0, N70
- ⑭ BITUMINOUS MATERIAL (PRIME COAT)
- ⑮ 4.75" HOT-MIX ASPHALT BINDER COURSE, IL-19.0, N50
- ⑯ 6.5" HOT-MIX ASPHALT BINDER COURSE, IL-19.0, N50
- ⑰ #6 TIE BARS (FOR MORE INFO SEE GENERAL NOTES SHEETS)
- ⑱ PORTLAND CEMENT CONCRETE BASE COURSE, 10"
- ⑲ HOT-MIX ASPHALT SURFACE REMOVAL, 2.25"
- ⑳ 1.5" POLYMERIZED HOT-MIX ASPHALT SURFACE COURSE, MIX "E", N70
- ㉑ 0.75" POLYMERIZED LEVELING BINDER (MACHINE METHOD), N70
- ㉒ 2" HOT-MIX ASPHALT SURFACE COURSE, MIX "C" N50
- ㉓ SUB-BASE GRANULAR MATERIAL, TYPE A, 21" (STA. 993+00 TO STA. 1002+50 AND STA. 1021+50 TO STA. 1022+20.19)
- ㉔ POLYMERIZED BITUMINOUS MATERIAL (PRIME COAT)
- ㉕ GEOTECHNICAL REINFORCEMENT

PCC PAVEMENT THICKNESS TABLE

ROADWAY	THICKNESS
RALSTON RD /IL 173	9.5"
IL 251	9.5"
ALPINE RD	9.5"
ORLANDO ST/N 2ND FRONTAGE RD	8.25"

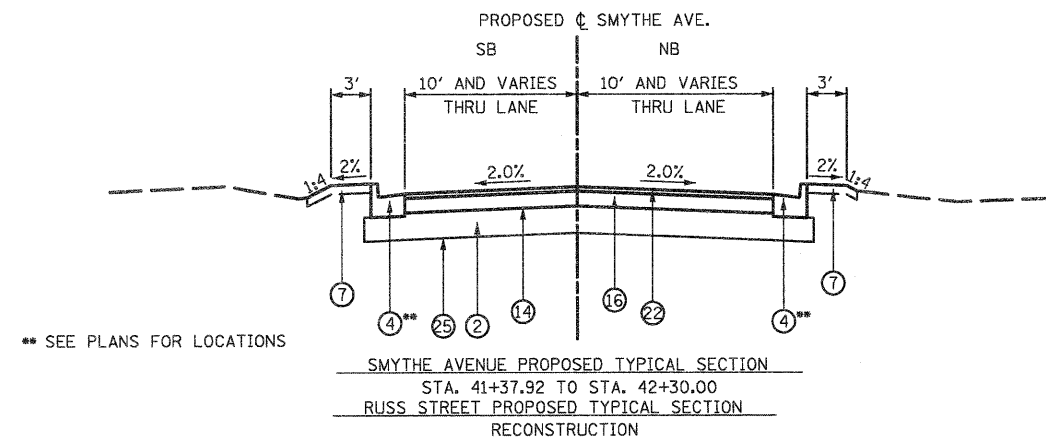

SMYTHE AVE. FLEXIBLE PAVEMENT

STRUCTURAL DESIGN TRAFFIC:	YEAR 2021		
PV=	3445	SU= 295	MU= 60
ROAD/STREET CLASSIFICATION:	CLASS III		
P=	50%	S= 50%	M= 50%
TRAFFIC FACTOR:	ACTUAL TF= 0.56	AC TYPE=	20
	MINIMUM TF=		
PG GRADE:	BINDER= PG 64-22	SURFACE=	PG 64-22
SUBGRADE SUPPORT RATING:			
SSR=	POOR	(STA. 41+37.92 TO 42+30.00)	
SSR=		(STA. TO)	

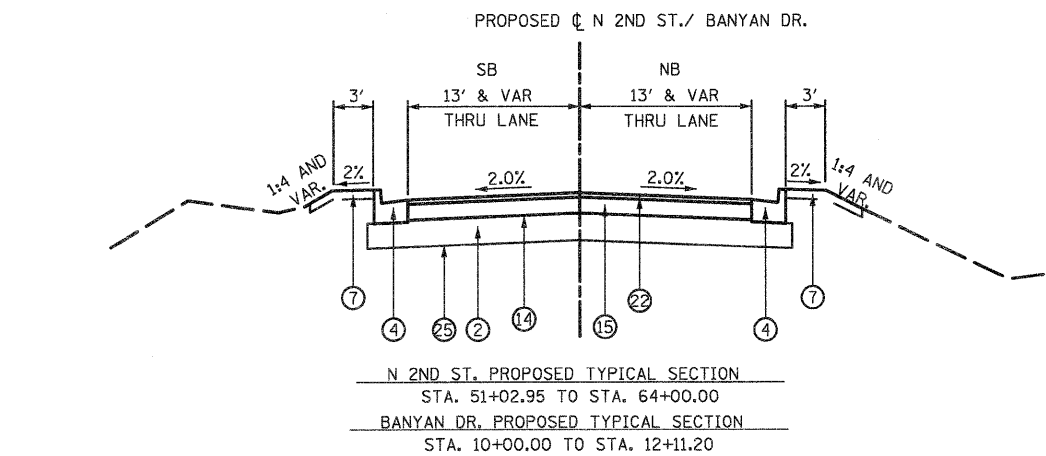

N 2ND ST/BAYAN DR. FLEXIBLE PAVEMENT

STRUCTURAL DESIGN TRAFFIC:	YEAR 2021		
PV=	1320	SU= 115	MU= 15
ROAD/STREET CLASSIFICATION:	CLASS III		
P=	50%	S= 50%	M= 50%
TRAFFIC FACTOR:	ACTUAL TF= 0.19	AC TYPE=	20
	MINIMUM TF=		
PG GRADE:	BINDER= PG 64-22	SURFACE=	PG 64-22
SUBGRADE SUPPORT RATING:			
SSR=	POOR (N 2ND ST)	(STA. 51+02.95 TO 64+00.00)	
SSR=	POOR (BAYAN DR.)	(STA. 10+00.00 TO 12+11.20)	

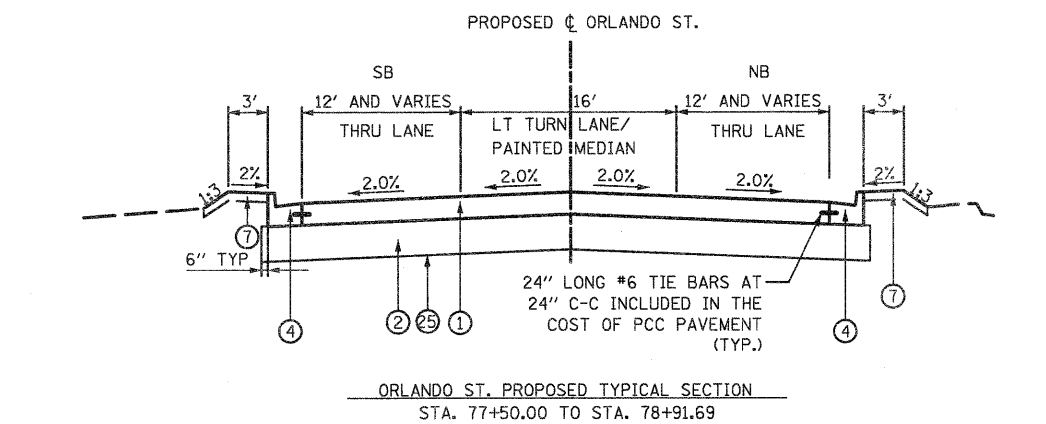

ORLANDO ST/N 2ND FRONTAGE RD. PCC PAVEMENT

STRUCTURAL DESIGN TRAFFIC:	YEAR 2021		
PV=	9230	SU= 440	MU= 80
ROAD/STREET CLASSIFICATION:	CLASS I		
P=	50%	S= 50%	M= 50%
TRAFFIC FACTOR:	ACTUAL TF= 1.03	AC TYPE=	N/A
	MINIMUM TF=		
PG GRADE:	BINDER=	SURFACE=	
SUBGRADE SUPPORT RATING:			
SSR=	POOR (ORLANDO ST)	(STA. 77+50.00 TO 78+91.69)	
SSR=	POOR (N 2ND FRONTAGE RD)	(STA. 311+40.14 TO 313+90.12)	

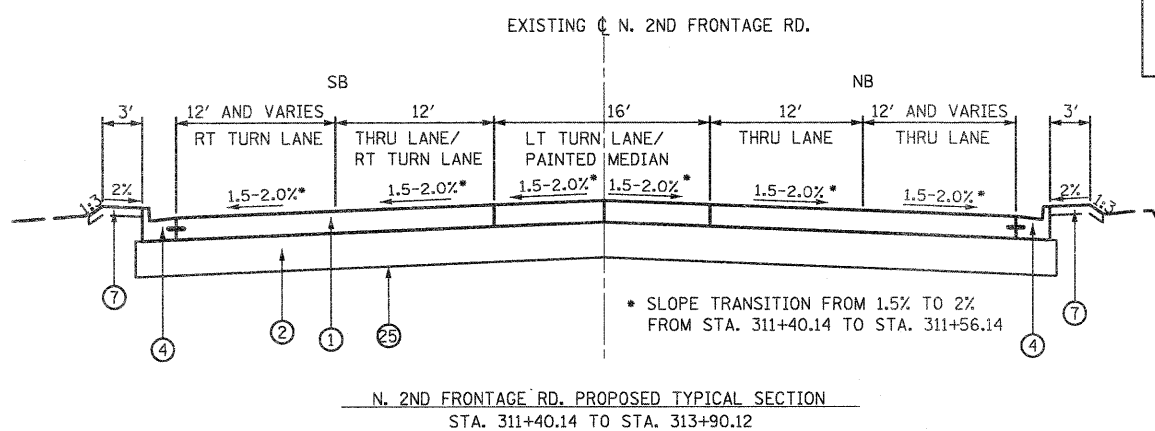

NOTE:
SEE GENERAL NOTES SHEETS FOR HMA PAVEMENT REQUIREMENTS.

FILE NAME = 0264987-shr-typical-PR04.dgn	USER NAME = 3202090971	DESIGNED - LOM	REVISED -	STATE OF ILLINOIS DEPARTMENT OF TRANSPORTATION	PROPOSED TYPICAL SECTIONS				F.A.P. RTE. 303	SECTION 129K-1	COUNTY WINNEBAGO	TOTAL SHEETS 401	SHEET NO. 21
	PLLOT SCALE = NTS	DRAWN - MD	REVISED -		SMYTHE AVE\N. 2ND ST\BANYAN DR\ORLANDO ST\N. 2ND FRONTAGE RD								
	PLLOT DATE = 1/18/2011	CHECKED - PDK	REVISED -		SCALE: NTS SHEET NO. OF SHEETS STA. TO STA.				CONTRACT NO. 64987				
		DATE - 01-19-2011	REVISED -		FED. ROAD DIST. NO. 2 ILLINOIS FED. AID PROJECT								

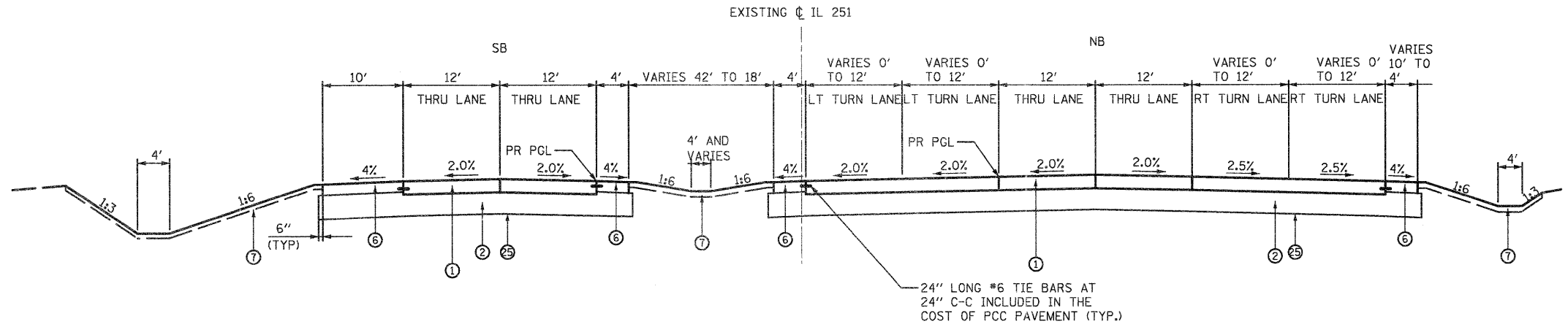

IL 251 PROPOSED TYPICAL SECTION
STA. 862+93.96 TO STA. 870+76.00

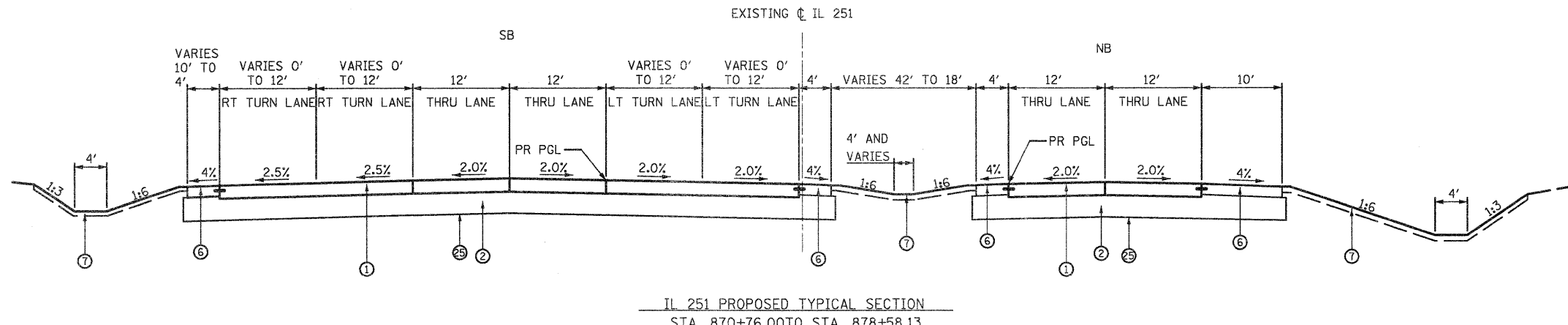

IL 251 PROPOSED TYPICAL SECTION
STA. 870+76.00 TO STA. 878+58.13

- PROPOSED LEGEND:**
- ① PORTLAND CEMENT CONCRETE PAVEMENT (JOINTED), SEE TABLE THIS SHEET FOR THICKNESS
 - ② SUB-BASE GRANULAR MATERIAL, TYPE A, 12"
 - ③ HOT-MIX ASPHALT MEDIAN WITH PAVEMENT COLOR AND TEXTURE (SPECIAL)
 - ④ COMBINATION CONCRETE CURB AND GUTTER B-6.24
 - ⑤ COMBINATION CONCRETE CURB AND GUTTER B-6.12
 - ⑥ PORTLAND CEMENT CONCRETE SHOULDER, 9.5"
 - ⑦ TOPSOIL FURNISH AND PLACE, 4"
 - ⑧ CORRUGATED MEDIAN
 - ⑨ COMBINATION CONCRETE CURB AND GUTTER B-6.18
 - ⑩ COMBINATION CONCRETE CURB AND GUTTER B-6.06
 - ⑪ CONCRETE MEDIAN, TYPE SB-6.06
 - ⑫ 2" POLYMERIZED HOT-MIX ASPHALT SURFACE COURSE, MIX "E" N70
 - ⑬ 10.75" POLYMERIZED HOT-MIX ASPHALT BINDER COURSE, IL-19.0, N70
 - ⑭ BITUMINOUS MATERIAL (PRIME COAT)
 - ⑮ 4.75" HOT-MIX ASPHALT BINDER COURSE, IL-19.0, N50
 - ⑯ 6.5" HOT-MIX ASPHALT BINDER COURSE, IL-19.0, N50
 - ⑰ #6 TIE BARS (FOR MORE INFO SEE GENERAL NOTES SHEETS)
 - ⑱ PORTLAND CEMENT CONCRETE BASE COURSE, 10"
 - ⑲ HOT-MIX ASPHALT SURFACE REMOVAL, 2.25"
 - ⑳ 1.5" POLYMERIZED HOT-MIX ASPHALT SURFACE COURSE, MIX "E", N70
 - ㉑ 0.75" POLYMERIZED LEVELING BINDER (MACHINE METHOD), N70
 - ㉒ 2" HOT-MIX ASPHALT SURFACE COURSE, MIX "C" N50
 - ㉓ SUB-BASE GRANULAR MATERIAL, TYPE A, 21" (STA. 993+00 TO STA. 1002+50 AND STA. 1021+50 TO STA. 1022+20.19)
 - ㉔ POLYMERIZED BITUMINOUS MATERIAL (PRIME COAT)
 - ㉕ GEOTECHNICAL REINFORCEMENT

PCC PAVEMENT THICKNESS TABLE

ROADWAY	THICKNESS
RALSTON RD /IL 173	9.5"
IL 251	9.5"
ALPINE RD	9.5"
ORLANDO ST/N 2ND FRONTAGE RD	8.25"

IL 251 PCC PAVEMENT

STRUCTURAL DESIGN TRAFFIC:	YEAR 2021
PV= 39655	SU= 1035 MU= 665
ROAD/STREET CLASSIFICATION:	CLASS I
P= 32%	S= 45% M= 45%
TRAFFIC FACTOR:	ACTUAL TF= 6.03 AC TYPE= N/A
	MINIMUM TF=
PG GRADE: BINDER=	SURFACE=
SUBGRADE SUPPORT RATING:	
SSR= POOR	(STA. 862+93.96 TO 878+58.13)
SSR=	(STA. TO)

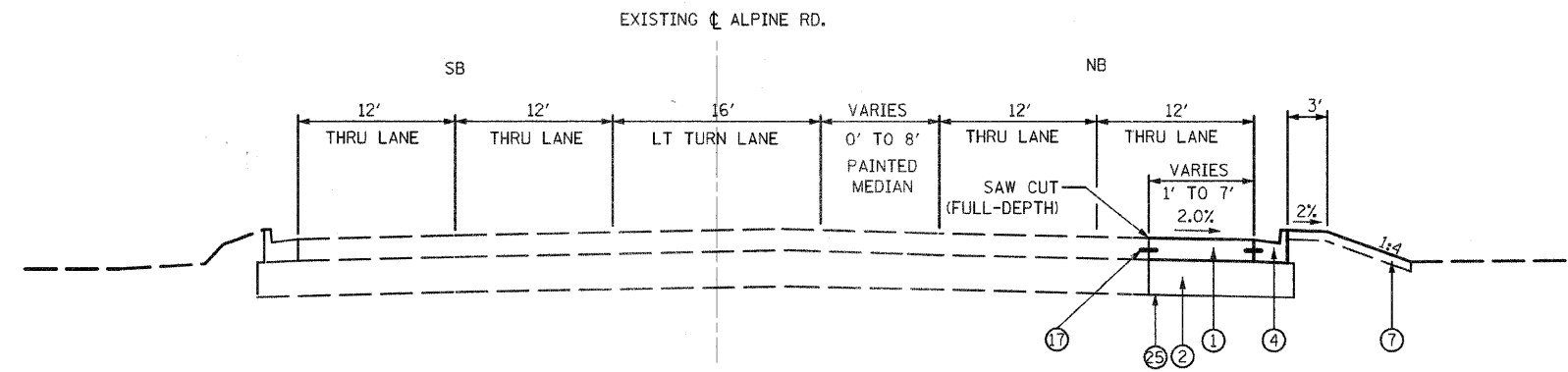

ALPINE RD. PROPOSED TYPICAL SECTION
STA. 259+63.78 TO STA. 262+82.70

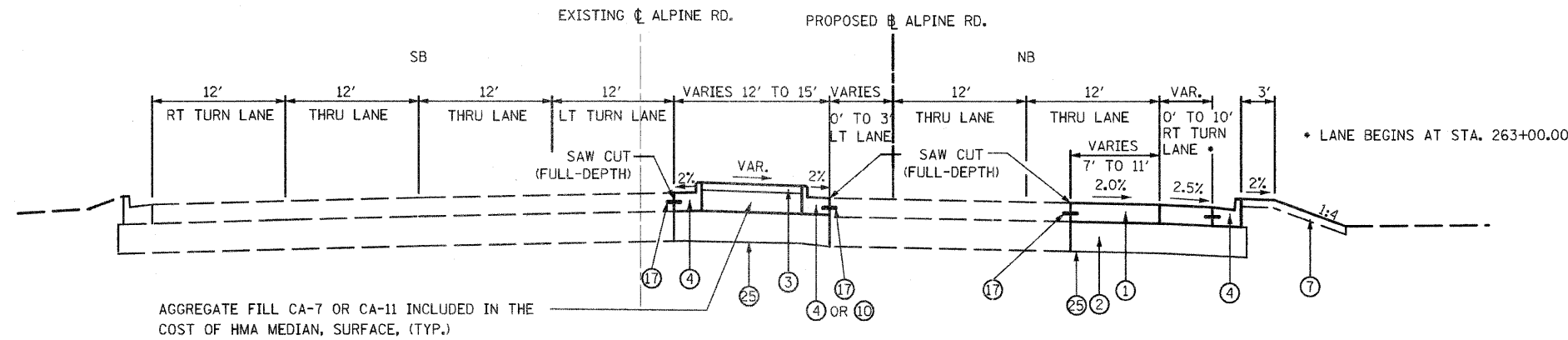

ALPINE RD. PROPOSED TYPICAL SECTION
STA. 262+82.70 TO STA. 264+30.00

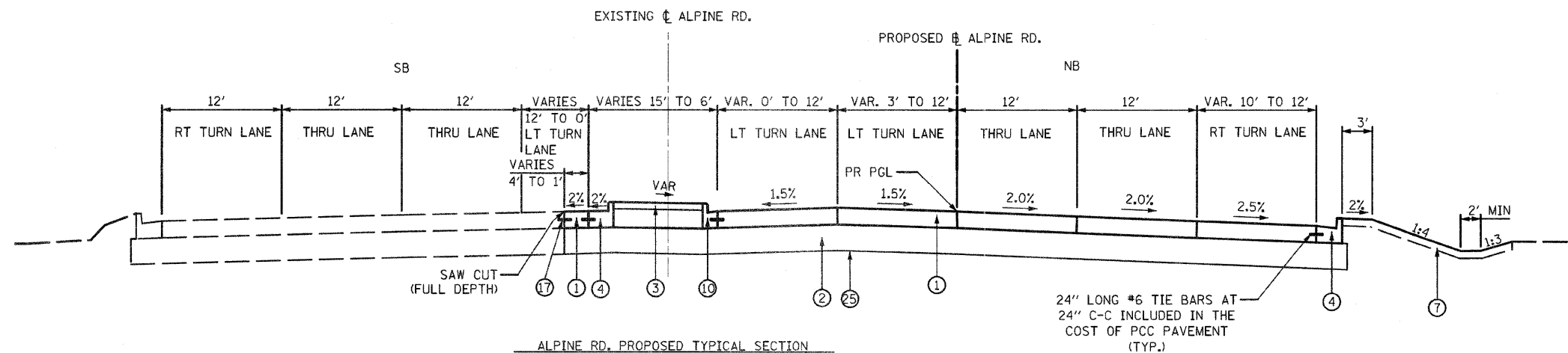

ALPINE RD. PROPOSED TYPICAL SECTION
STA. 264+30.00 TO STA. 267+00.00

NOTE: PROFILE GRADE LINE (PGL) CORRESPONDS TO BASELINE SHOWN ON THE PLANS.

PROPOSED LEGEND:

- ① PORTLAND CEMENT CONCRETE PAVEMENT (JOINTED), SEE TABLE THIS SHEET FOR THICKNESS
- ② SUB-BASE GRANULAR MATERIAL, TYPE A, 12"
- ③ HOT-MIX ASPHALT MEDIAN WITH PAVEMENT COLOR AND TEXTURE (SPECIAL)
- ④ COMBINATION CONCRETE CURB AND GUTTER B-6.24
- ⑤ COMBINATION CONCRETE CURB AND GUTTER B-6.12
- ⑥ PORTLAND CEMENT CONCRETE SHOULDER, 9.5"
- ⑦ TOPSOIL FURNISH AND PLACE, 4"
- ⑧ CORRUGATED MEDIAN
- ⑨ COMBINATION CONCRETE CURB AND GUTTER B-6.18
- ⑩ COMBINATION CONCRETE CURB AND GUTTER B-6.06
- ⑪ CONCRETE MEDIAN, TYPE SB-6.06
- ⑫ 2" POLYMERIZED HOT-MIX ASPHALT SURFACE COURSE, MIX "E" N70
- ⑬ 10.75" POLYMERIZED HOT-MIX ASPHALT BINDER COURSE, IL-19.0, N70
- ⑭ BITUMINOUS MATERIAL (PRIME COAT)
- ⑮ 4.75" HOT-MIX ASPHALT BINDER COURSE, IL-19.0, N50
- ⑯ 6.5" HOT-MIX ASPHALT BINDER COURSE, IL-19.0, N50
- ⑰ #6 TIE BARS (FOR MORE INFO SEE GENERAL NOTES SHEETS)
- ⑱ PORTLAND CEMENT CONCRETE BASE COURSE, 10"
- ⑲ HOT-MIX ASPHALT SURFACE REMOVAL, 2.25"
- ⑳ 1.5" POLYMERIZED HOT-MIX ASPHALT SURFACE COURSE, MIX "E", N70
- ㉑ 0.75" POLYMERIZED LEVELING BINDER (MACHINE METHOD), N70
- ㉒ 2" HOT-MIX ASPHALT SURFACE COURSE, MIX "C" N50
- ㉓ SUB-BASE GRANULAR MATERIAL, TYPE A, 21" (STA. 993+00 TO STA. 1002+50 AND STA. 1021+50 TO STA. 1022+20.19)
- ㉔ POLYMERIZED BITUMINOUS MATERIAL (PRIME COAT)
- ㉕ GEOTECHNICAL REINFORCEMENT

PCC PAVEMENT THICKNESS TABLE

ROADWAY	THICKNESS
RALSTON RD /IL 173	9.5"
IL 251	9.5"
ALPINE RD	9.5"
ORLANDO ST/N 2ND FRONTAGE RD	8.25"

ALPINE RD. PCC PAVEMENT

STRUCTURAL DESIGN TRAFFIC:	YEAR 2021	
PV=23240	SU= 1190	MU= 370
ROAD/STREET CLASSIFICATION:	CLASS II	
P= 50%	S= 50%	M= 50%
TRAFFIC FACTOR:	ACTUAL TF= 5.51	AC TYPE= N/A
	MINIMUM TF=	
PG GRADE: BINDER=		SURFACE=
SUBGRADE SUPPORT RATING:		
SSR= POOR	(STA. 259+63.78 TO 275+00.00)	
SSR=	(STA. TO)	

FILE NAME = 0264987-shr-typical-PR06.dgn

USER NAME = 3202098971
PLOT SCALE = NTS
PLOT DATE = 3/16/2011

DESIGNED LOM
DRAWN MD
CHECKED PDK
DATE 03-16-2011

REVISED -
REVISED -
REVISED -
REVISED -

STATE OF ILLINOIS
DEPARTMENT OF TRANSPORTATION

PROPOSED TYPICAL SECTIONS
ALPINE ROAD

SCALE: NTS SHEET NO. OF SHEETS STA. TO STA.

F.A.P. RTE.	SECTION	COUNTY	TOTAL SHEETS	SHEET NO.
303	129K-1	WINNEBAGO	401	23

CONTRACT NO. 64987
FED. ROAD DIST. NO. 2 ILLINOIS FED. AID PROJECT

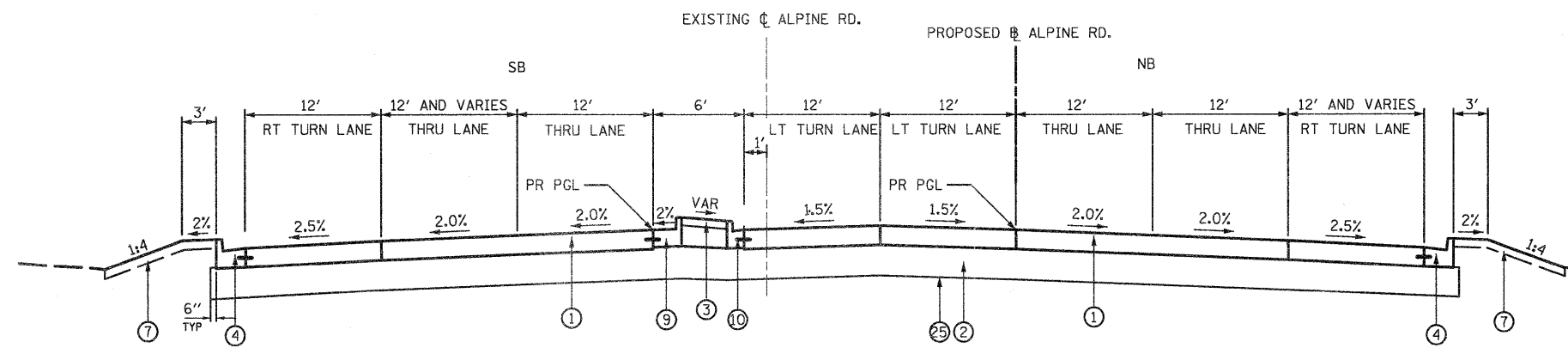

ALPINE RD. PROPOSED TYPICAL SECTION
STA. 267+00.00 TO STA. 270+00.00

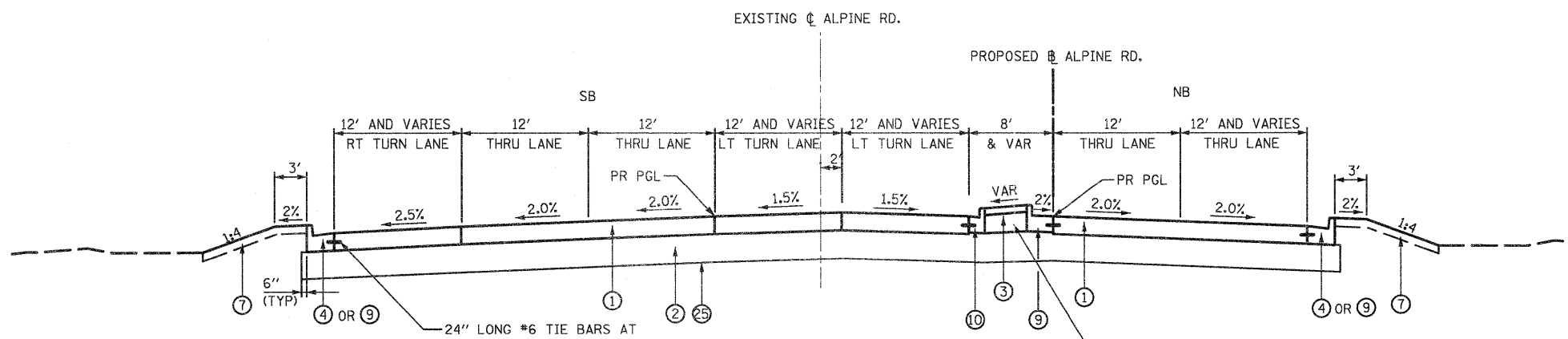

ALPINE RD. PROPOSED TYPICAL SECTION
STA. 270+00.00 TO STA. 275+00.00

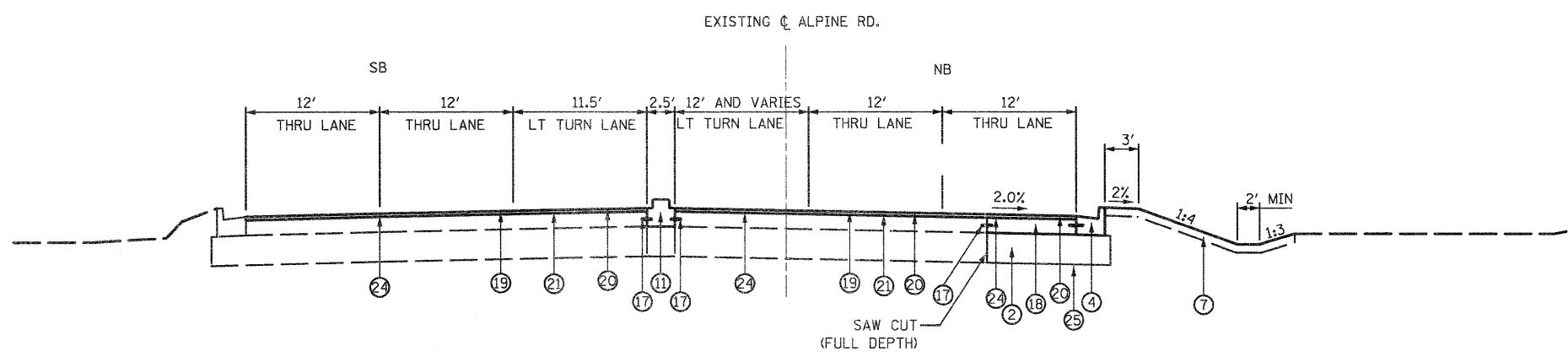

ALPINE RD. PROPOSED TYPICAL SECTION
STA. 275+00.00 TO STA. 277+80.26

PROPOSED LEGEND:

- ① PORTLAND CEMENT CONCRETE PAVEMENT (JOINTED), SEE TABLE THIS SHEET FOR THICKNESS
- ② SUB-BASE GRANULAR MATERIAL, TYPE A, 12"
- ③ HOT-MIX ASPHALT MEDIAN WITH PAVEMENT COLOR AND TEXTURE (SPECIAL)
- ④ COMBINATION CONCRETE CURB AND GUTTER B-6.24
- ⑤ COMBINATION CONCRETE CURB AND GUTTER B-6.12
- ⑥ PORTLAND CEMENT CONCRETE SHOULDER, 9.5"
- ⑦ TOPSOIL FURNISH AND PLACE, 4"
- ⑧ CORRUGATED MEDIAN
- ⑨ COMBINATION CONCRETE CURB AND GUTTER B-6.18
- ⑩ COMBINATION CONCRETE CURB AND GUTTER B-6.06
- ⑪ CONCRETE MEDIAN, TYPE SB-6.06
- ⑫ 2" POLYMERIZED HOT-MIX ASPHALT SURFACE COURSE, MIX "E" N70
- ⑬ 10.75" POLYMERIZED HOT-MIX ASPHALT BINDER COURSE, IL-19.0, N70
- ⑭ BITUMINOUS MATERIAL (PRIME COAT)
- ⑮ 4.75" HOT-MIX ASPHALT BINDER COURSE, IL-19.0, N50
- ⑯ 6.5" HOT-MIX ASPHALT BINDER COURSE, IL-19.0, N50
- ⑰ #6 TIE BARS (FOR MORE INFO SEE GENERAL NOTES SHEETS)
- ⑱ PORTLAND CEMENT CONCRETE BASE COURSE, 10"
- ⑲ HOT-MIX ASPHALT SURFACE REMOVAL, 2.25"
- ⑳ 1.5" POLYMERIZED HOT-MIX ASPHALT SURFACE COURSE, MIX "E", N70
- ㉑ 0.75" POLYMERIZED LEVELING BINDER (MACHINE METHOD), N70
- ㉒ 2" HOT-MIX ASPHALT SURFACE COURSE, MIX "C" N50
- ㉓ SUB-BASE GRANULAR MATERIAL, TYPE A, 21" (STA. 993+00 TO STA. 1002+50 AND STA. 1021+50 TO STA. 1022+20.19)
- ㉔ POLYMERIZED BITUMINOUS MATERIAL (PRIME COAT)
- ㉕ GEOTECHNICAL REINFORCEMENT

PCC PAVEMENT THICKNESS TABLE

ROADWAY	THICKNESS
RALSTON RD /IL 173	9.5"
IL 251	9.5"
ALPINE RD	9.5"
ORLANDO ST/N 2ND FRONTAGE RD	8.25"

- NOTES:
- SEE GENERAL NOTES SHEETS FOR HMA PAVEMENT REQUIREMENTS.
 - PROFILE GRADE LINE (PGL) CORRESPONDS TO BASELINE SHOWN ON THE PLANS.

FILE NAME = 0264987-shr-typical-PR07.dgn	USER NAME = 3202090971	DESIGNED - LOM	REVISED -	STATE OF ILLINOIS DEPARTMENT OF TRANSPORTATION	PROPOSED TYPICAL SECTIONS ALPINE ROAD			F.A.P. RTE. 303	SECTION 129K-1	COUNTY WINNEBAGO	TOTAL SHEETS 401	SHEET NO. 24	
PLOT SCALE = NTS					SCALE: NTS			SHEET NO. OF SHEETS STA. TO STA.			CONTRACT NO. 64987		
PLOT DATE = 1/18/2011					DATE - 01-19-2011			FED. ROAD DIST. NO. 2			ILLINOIS FED. AID PROJECT		

SCHEDULE OF QUANTITIES

20100110 TREE REMOVAL (6 TO 15 UNITS DIA.)				
STATION	OFFSET (FT)	DIA INCH	UNIT	
RALSTON RD				
987+79.44	46.17	LT	6.05	6
989+74.42	59.99	LT	7.03	7
989+80.19	61.70	LT	7.00	7
989+82.74	46.95	LT	9.09	9
989+84.36	43.47	LT	13.00	13
989+90.07	40.46	LT	6.00	6
989+95.71	39.59	LT	7.03	7
989+90.26	45.34	LT	9.00	9
989+90.65	50.28	LT	7.00	7
989+85.81	51.34	LT	7.00	8
993+19.88	52.86	RT	11.06	11
993+39.67	44.90	RT	11.06	11
993+50.75	61.60	RT	9.03	9
993+54.30	66.01	RT	9.00	9
993+62.58	70.42	RT	12.00	12
993+79.46	71.32	RT	13.00	13
993+67.23	67.31	RT	12.05	12
993+60.14	66.29	RT	12.00	12
993+54.87	60.51	RT	9.00	9
994+36.44	43.68	RT	10.02	10
994+40.22	60.50	RT	9.06	9
994+43.92	69.18	RT	9.09	9
994+51.65	71.43	RT	9.00	9
994+46.66	62.15	RT	9.00	9
994+57.27	60.83	RT	10.05	10
994+08.84	77.60	RT	12.00	12
994+15.91	70.37	RT	12.09	12
994+21.83	78.61	RT	12.05	12
994+19.30	93.63	RT	11.05	11
994+33.38	96.08	RT	11.00	11
994+15.13	115.16	RT	11.05	11
994+41.24	115.02	RT	12.02	12
994+45.38	112.47	RT	12.05	12
994+43.31	126.40	RT	11.03	11
994+56.95	111.53	RT	7.06	7
994+55.39	118.83	RT	14.04	14
994+51.28	122.22	RT	7.02	7
994+53.87	126.60	RT	12.05	12
994+50.01	130.23	RT	10.05	10
994+49.64	92.20	RT	8.02	8
994+72.01	82.41	RT	12.00	12
994+63.38	88.59	RT	12.00	12
994+61.82	95.18	RT	12.07	12
994+82.08	106.47	RT	15.04	15
994+81.20	122.34	RT	8.08	8
994+77.35	138.59	RT	11.00	11
994+80.83	134.10	RT	14.03	14
994+88.33	129.66	RT	10.00	10
994+50.65	175.48	RT	11.02	11

20100110 TREE REMOVAL (6 TO 15 UNITS DIA.)				
STATION	OFFSET (FT)	DIA INCH	UNIT	
RALSTON RD				
994+62.41	168.91	RT	12.00	12
994+75.86	157.68	RT	11.00	11
994+85.76	168.96	RT	11.00	11
994+73.39	208.48	RT	9.00	9
994+73.43	219.58	RT	10.05	10
994+79.24	230.94	RT	10.00	10
994+66.78	225.06	RT	10.00	10
994+90.34	262.55	RT	12.00	12
995+01.78	253.03	RT	12.00	12
995+14.94	270.37	RT	12.05	12
995+03.16	283.30	RT	13.00	13
994+37.83	231.91	RT	11.00	11
998+98.63	75.93	RT	10.03	10
998+98.04	76.25	RT	6.05	6
ILLINOIS ROUTE 173				
1017+33.77	105.05	RT	17.05	17
1017+48.26	105.55	RT	13.05	13
N. 2ND STREET				
52+50.93	8.22	LT	6.03	6
52+84.28	10.57	LT	6.03	6
53+43.60	16.28	LT	6.06	6
54+06.99	16.36	LT	6.02	6
54+51.06	20.80	LT	6"	6
58+01.22	31.85	LT	12.06	12
ORLANDO STREET				
78+67.02	35.09	LT	9.00	9
ALPINE RD				
270+96.15	84.67	RT	6.08	6
271+20.73	62.00	RT	7.02	7
271+75.66	59.96	RT	7.00	7
273+14.33	67.39	RT	6.05	6
274+04.34	65.70	RT	7.00	7
TOTAL				765

20100210 TREE REMOVAL (OVER 15 UNITS)				
STATION	OFFSET (FT)	DIA INCH	UNIT	
RALSTON RD				
991+57.01	44.43	LT	26.07	26
992+74.15	43.02	RT	28.00	28
992+49.34	60.85	RT	28.00	28
994+76.87	56.88	RT	22.06	22
994+80.81	52.95	RT	23.05	23
994+95.01	124.95	RT	15.08	15
999+13.61	68.92	RT	31.06	31
ILLINOIS ROUTE 173				
1017+81.03	72.14	RT	40.00	40
1017+98.56	57.95	RT	40.00	40
1017+81.07	98.11	RT	34.08	34
TOTAL				287

20101100 TREE TRUNK PROTECTION				
STATION	OFFSET (FT)	EACH		
RALSTON RD				
985+16.63	40.36	RT	1	
985+89.51	43.25	RT	1	
986+44.68	49.60	LT	1	
986+62.47	48.59	LT	1	
988+78.70	53.02	LT	1	
988+57.60	45.40	RT	1	
992+49.34	60.85	RT	1	
992+65.43	80.02	RT	1	
993+73.32	93.29	RT	1	
994+35.50	236.59	RT	1	
995+41.70	241.54	RT	1	
ILLINOIS ROUTE 173				
1013+27.45	79.24	RT	1	
1013+83.89	76.75	RT	1	
1023+23.32	74.44	LT	1	
1024+08.43	92.08	RT	1	
1026+38.10	58.19	LT	1	
1026+46.19	58.12	LT	1	
1026+95.91	54.71	LT	1	
1027+23.46	58.78	LT	1	
1027+46.04	57.64	LT	1	
SMYTHE AVENUE				
41+88.41	32.19	LT	1	
42+15.96	30.24	LT	1	
42+33.52	32.33	LT	1	
N. 2ND STREET				
51+97.15	82.39	LT	1	
51+89.73	93.55	LT	1	
51+89.16	109.55	LT	1	
52+00.57	119.31	LT	1	
60+12.95	40.36	LT	1	
ILLINOIS ROUTE 251				
862+76.08	114.52	RT	1	
863+23.36	115.81	RT	1	
863+93.33	116.04	RT	1	
ALPINE RD				
272+31.64	79.92	RT	1	
273+14.33	67.39	RT	1	
273+61.44	66.27	RT	1	
274+04.34	65.70	RT	1	
274+49.72	67.82	RT	1	
TOTAL				36

LOCATION	28000305	28000400	28000500
	TEMPORARY DITCH CHECKS	PERIMETER EROSION BARRIER	INLET AND PIPE PROTECTION
	FOOT	FOOT	EACH
PRE-STAGE 1	144	3152.4	5
PRE-STAGE 2	8	642	--
PRE-STAGE 3	--	418	--
WINTER STAGE	4	9542.5	39
STAGE 1A	128	6790.4	15
STAGE 1B	48	--	8
STAGE 1C	88	--	--
STAGE 2A	88	3245	32
STAGE 2B	32	--	41
STAGE 2C	40	--	7
STAGE 3	8	--	5
STAGE 4A AND 4B	--	--	--
TOTAL	588	23790.3	152

25100900 TURF REINFORCEMENT MAT				
LOCATION	OFFSET	AREA	COMMENTS	
STATION TO STATION		SQ YD		
IL ROUTE 173				
1009+47.62	1011+13.8	LT	457	CHANNEL BOTTOM
1012+85.14	1018+44.15	LT	2154	CHANNEL BOTTOM
TOTAL			2611	

28500400 ARTICULATED BLOCK REVETMENT MAT				
LOCATION	OFFSET	AREA	COMMENTS	
STATION TO STATION		SQ YD		
IL 173				
1018+44.15	1019+04.20	LT	408	CHANNEL BOTTOM
TOTAL			408	

DESC.	STATION	OFFSET	PIPE SIZE	W1	W2	La	GRADATION	PAY ITEM NO.	28100105	28100109	28200200
								STONE RIPRAP CL A3 (SQ YD)	STONE RIPRAP CL A5 (SQ YD)	FILTER FABRIC (SQ YD)	
OUTLET 4	1015+99.17	99.12' LT	15"	3.75	6.05	12	RR 3	7			
OUTLET 5	1013+44.80	82.05' LT	12"	3	5.8	12	RR 3	6			
OUTLET 8	1005+90.52	66.00' LT	24"	6	7.6	14	RR 3	11			
OUTLET 9	995+80.00	103.00' LT	30"	7.5	14.5	18	RR 3	22			
OUTLET 10	997+50.01	97.88' LT	15"	3.75	13.25	12	RR 3	11			
OUTLET 11	999+74.77	99.73' LT	15"	3.75	13.25	12	RR 3	11			
OUTLET 12	52+37.13	48.36' RT	15"	3.75	13.25	12	RR 3	11			
OUTLET 13	55+00.00	32.71' RT	15"	3.75	13.25	12	RR 3	11			
OUTLET 14	57+00.00	34.66' RT	12"	3	11	10	RR 3	8			
OUTLET 15	59+00.00	36.89' RT	12"	3	11	10	RR 3	8			
OUTLET 17	54+09.86	40.71' RT	15"	3.75	13.25	12	RR 3	11			
OUTLET 18	869+50.00	98.12' LT	12"	3	11	10	RR 3	8			
OUTLET 20	872+00.00	109.87' LT	15"	3.75	13.25	12	RR 3	11			
FRONTAGE	1011+33.55	103.22' LT	(3) 11' X 6'			30	RR 5		204	204	
IL 173	1007+74.52	74.51' RT	(3) 11' X 6'			30	RR 5		396	396	
TOTAL								136	600	600	

TREE SCHEDULE				
NUMBER	COMMON NAME	LATIN NAME	SIZE	UNIT
A2000114	AUTUM BLAZE FREEMAN	ACER X FREEMANII	1 3/4" BB	15
A2001714	SUGAR MAPEL	ACER SACCHARUM	1 3/4" BB	20
B2002614	CRABAPPLE	MALUS ADAM TF	1 3/4" BB	15
B2004814	CRABAPPLE, DWARF	MALUS SARGENTI TF	1 3/4" BB	17
A2006714	BUR OAK	QUERCUS MACROCRAP	1 3/4" BB	9

EARTHWORK SCHEDULE

IL 173 EARTHWORK								
LOCATION			EARTH EXC (CUT)	EARTH EXC ADJ SHRINK 25% EARTH	EMBANK (FILL)	EARTHWORK BALANCE WASTE (+) SHORTAGE(-)	REM AND DISP OF UNSUIT MATERIAL*	TOPSOIL FURNISH AND PLACE 4"
STATION	TO	STATION	CU YD	CU YD	CU YD	CU YD	CU YD	SQ YD
PRE-STAGE 1								
1006+50.00		1007+50.00	25	19	56	-37	20	0
1007+50.00		1016+50.00	355	267	1,054	-787	239	0
PRE-STAGE 2								
1006+50.00		1007+50.00	28	21	23	-2	14	0
1007+50.00		1019+00.00	5,940	4,455	5,161	-705	1,023	4,278
PRE-STAGE 3								
985+50.00		992+50.00	604	453	9	444	144	0
992+50.00		1007+50.00	323	242	230	12	180	0
1007+50.00		1022+50.00	264	198	234	-36	99	0
1022+50.00		1033+00.00	391	293	50	243	108	0
PRE-STAGE SUB-TOTAL=			7,931	5,948	6,817	-868	1,826	4,278
STAGE 1								
985+00.00		992+50.00	1,477	1,108	28	1,080	252	91
992+50.00		1007+50.00	6,151	4,614	2,153	2,461	1,672	7,463
1007+50.00		1022+50.00	173	130	4,831	-4,701	242	3,737
1022+50.00		1036+00.00	725	544	883	-339	327	94
STAGE 2								
985+50.00		992+50.00	813	610	350	259	70	1,279
992+50.00		1007+50.00	7,408	5,556	2,427	3,129	1,012	8,368
1007+50.00		1022+50.00	1,098	823	7,066	-6,242	697	5,835
1022+50.00		1033+00.00	730	547	1,039	-491	156	2,593
STAGE 3								
985+00.00		992+50.00	192	144	511	-367	0	0
1023+00.00		1033+50.00	311	233	201	32	0	57
STAGE SUB-TOTAL=			19,077	14,308	19,489	-5,181	4,429	29,517

* 4" TO 6" EXISTING TOPSOIL REMOVAL

SMYTHE AVE EARTHWORK								
LOCATION			EARTH EXC (CUT)	EARTH EXC ADJ SHRINK 25% EARTH	EMBANK (FILL)	EARTHWORK BALANCE WASTE (+) SHORTAGE(-)	REM AND DISP OF UNSUIT MATERIAL*	TOPSOIL FURNISH AND PLACE 4"
STATION	TO	STATION	CU YD	CU YD	CU YD	CU YD	CU YD	SQ YD
STAGE 2								
41+00.00		42+30.00	373	280	6	274	37	193
STAGE SUB-TOTAL=			373	280	6	274	37	193

* 4" EXISTING TOPSOIL REMOVAL

BANYAN DR EARTHWORK								
LOCATION			(CUT)	ADJ SHRINK	(FILL)	WASTE (+)	UNSUIT MATERIAL*	FURNISH
STATION	TO	STATION	CU YD	CU YD	CU YD	CU YD	CU YD	SQ YD
STAGE 2								
10+00.00		13+20.20	517	387	139	249	230	548
STAGE SUB-TOTAL=			517	387	139	249	230	548

*4" EXISTING TOPSOIL REMOVAL

IL 251 EARTHWORK								
LOCATION			EARTH EXC (CUT)	EARTH EXC ADJ SHRINK 25% EARTH	EMBANK (FILL)	EARTHWORK BALANCE WASTE (+) SHORTAGE(-)	REM AND DISP OF UNSUIT MATERIAL*	TOPSOIL FURNISH AND PLACE 4"
STATION	TO	STATION	CU YD	CU YD	CU YD	CU YD	CU YD	SQ YD
PRE-STAGE 3								
857+50.00		870+00.00	715	537	1,387	-851	875	0
871+50.00		875+00.00	75	56	224	-168	119	0
875+00.00		883+50.00	411	308	1,076	-768	564	0
PRE-STAGE SUB-TOTAL=			1,201	901	2,687	-1,786	1,558	0
STAGE 1A								
871+50.00		875+00.00	343	257	598	-341	338	254
875+00.00		880+00.00	396	297	733	-436	414	0
STAGE 1B								
871+50.00		875+00.00	540	405	372	33	77	735
875+00.00		879+00.00	457	343	288	55	0	452
STAGE 2A								
862+00.00		870+00.00	995	746	415	331	266	1,725
871+50.00		875+00.00	2,522	1,891	70	1,821	459	3,587
STAGE 2B								
861+00.00		870+00.00	2,635	1,976	560	1,416	287	3,505
874+00.00		875+00.00	467	350	13	337	61	638
875+00.00		880+00.00	1,321	990	42	949	151	1,398
STAGE 2C								
871+50.00		875+00.00	94	70	4	67	0	519
875+00.00		883+50.00	995	746	13	734	0	3,154
STAGE 4A								
857+50.00		870+00.00	1,122	841	25	816	0	3,628
873+00.00		875+00.00	47	35	12	24	0	564
875+00.00		881+00.00	258	193	68	125	0	2,225
STAGE SUB-TOTAL=			12,191	9,143	3,211	5,932	2,052	22,384

* 4" EXISTING TOPSOIL REMOVAL

ORLANDO ST EARTHWORK								
LOCATION			EARTH EXC (CUT)	EARTH EXC ADJ SHRINK 25% EARTH	EMBANK (FILL)	EARTHWORK BALANCE WASTE (+) SHORTAGE(-)	REM AND DISP OF UNSUIT MATERIAL*	TOPSOIL FURNISH AND PLACE 4"
STATION	TO	STATION	CU YD	CU YD	CU YD	CU YD	CU YD	SQ YD
PRE-STAGE 3								
77+00.00		79+00.00	82	61	1	60	27	0
PRE-STAGE SUB-TOTAL=			82	61	1	60	27	0
STAGE 1A								
75+90.84		79+50.00	312	234	1	233	16	33
STAGE 2A								
77+00.00		79+50.00	195	146	52	94	7	246
STAGE 4A								
77+00.00		79+00.00	27	20	32	-12	0	147
STAGE SUB-TOTAL=			534	401	85	315	23	425

* 4" EXISTING TOPSOIL REMOVAL

EARTHWORK SCHEDULE

N 2ND FRONTAGE RD EARTHWORK								
LOCATION			EARTH EXC (CUT)	EARTH EXC ADJ SHRINK 25% EARTH	EMBANK (FILL)	EARTHWORK BALANCE WASTE (+) SHORTAGE(-)	REM AND DISP OF UNSUIT MATERIAL*	TOPSOIL FURNISH AND PLACE 4"
STATION	TO	STATION	CU YD	CU YD	CU YD	CU YD	CU YD	SQ YD
PRE-STAGE 3								
311+00.00		313+90.12	215	161	2	159	63	0
PRE-STAGE SUB-TOTAL=			215	161	2	159	63	0
STAGE 1A								
311+00.00		313+90.12	275	206	57	149	34	310
STAGE 2A								
311+00.00		313+90.12	239	179	54	126	6	291
STAGE SUB-TOTAL=			514	386	111	275	40	601

* 4" EXISTING TOPSOIL REMOVAL

ALPINE RD EARTHWORK								
LOCATION			EARTH EXC (CUT)	EARTH EXC ADJ SHRINK 25% EARTH	EMBANK (FILL)	EARTHWORK BALANCE WASTE (+) SHORTAGE(-)	REM AND DISP OF UNSUIT MATERIAL*	TOPSOIL FURNISH AND PLACE 4"
STATION	TO	STATION	CU YD	CU YD	CU YD	CU YD	CU YD	SQ YD
PRE-STAGE 2								
270+50.00		272+00.00	141	106	206	-100	35	82
PRE-STAGE 3								
267+50.00		269+50.00	83	62	4	59	30	0
PRE-STAGE SUB-TOTAL=			225	168	210	-41	65	82
STAGE 1A								
259+63.78		269+00.00	841	631	221	410	240	981
271+00.00		272+50.00	113	85	587	-502	143	556
272+50.00		277+80.26	443	332	35	297	60	437
STAGE 2A								
267+00.00		269+00.00	260	195	17	178	30	123
271+00.00		272+50.00	74	56	547	-492	71	674
272+50.00		275+00.00	490	368	17	351	16	175
STAGE SUB-TOTAL=			2,221	1,666	1,424	242	560	2,946

* 4" EXISTING TOPSOIL REMOVAL

PRE-STAGE EARTHWORK TOTAL								
LOCATION			EARTH EXC (CUT)	EARTH EXC ADJ SHRINK 25% EARTH	EMBANK (FILL)	EARTHWORK BALANCE WASTE (+) SHORTAGE(-)	REM AND DISP OF UNSUIT MATERIAL*	TOPSOIL FURNISH AND PLACE 4"
STATION	TO	STATION	CU YD	CU YD	CU YD	CU YD	CU YD	SQ YD
IL 173			7,931	5,948	6,817	-868	1,826	4,278
SMYTHE AVE			0	0	0	0	0	0
BANYAN DR			0	0	0	0	0	0
IL 251			1,201	901	2,687	-1,786	1,558	0
ORLANDO ST			82	61	1	60	27	0
N 2ND FRONTAGE RD			215	161	2	159	63	0
ALPINE RD			225	168	210	-41	65	82
TOTAL			9,653	7,239	9,717	-2,477	3,539	4,360

* 4" EXISTING TOPSOIL REMOVAL

STAGE EARTHWORK TOTAL								
LOCATION			EARTH EXC (CUT)	EARTH EXC ADJ SHRINK 25% EARTH	EMBANK (FILL)	EARTHWORK BALANCE WASTE (+) SHORTAGE(-)	REM AND DISP OF UNSUIT MATERIAL*	TOPSOIL FURNISH AND PLACE 4"
STATION	TO	STATION	CU YD	CU YD	CU YD	CU YD	CU YD	SQ YD
IL 173			19,077	14,308	19,489	-5,181	4,429	29,517
SMYTHE AVE			373	280	6	274	37	193
BANYAN DR			517	387	139	249	230	548
IL 251			12,191	9,143	3,211	5,932	2,052	22,384
ORLANDO ST			534	401	85	315	23	425
N 2ND FRONTAGE RD			514	386	111	275	40	601
ALPINE RD			2,221	1,666	1,424	242	560	2,946
TOTAL			35,427	26,570	24,465	2,105	7,369	56,615

* 4" EXISTING TOPSOIL REMOVAL

20200100 EARTH EXCAVATION, TOTAL=	45,079	CU YD
20201200 REMOVAL AND DISPOSAL OF UNSUITABLE MATERIAL, TOTAL=	10,909	CU YD
20400800 FURNISHED EXCAVATION, TOTAL=	-2,477	CU YD
21101615 TOPSOIL FURNISH AND PLACE, 4", TOTAL =	60,975	SQ YD

STRUCTURAL EXCAVATION			
LOCATION			CU YD
STATION	TO	STATION	CU YD
IL 173			
1009+50.00		1019+00.00	1,706
ALPINE RD			
271+00.00		272+00.00	282
TOTAL			1,988

SCHEDULE OF QUANTITIES

LOCATION			25000210	25000314	25000400	25000500	25000600	25100115	25000750	25100630	25200110	25200200	28000250
			SEEDING CL 2A	SEEDING CL 4B	NITROGEN FERT NUTR	PHOSPHORUS FERT NUTR	POTASSIUM FERT NUTR	MULCH, METHOD 2	MOWING	EROSION CONTR BLANKET	SODDING SALT TOLERANT	SUPPLE WATERING	TEMP EROS CONTR SEED
STATION TO STATION	OFFSEET	ACRE	ACRE	POUND	POUND	POUND	ACRE	ACRE	SQ YD	SQ YD	UNIT	POUND	
RALSTON RD													
985+00.00	992+50.00	LT	0.00		30.87	31	31	0.00		1532	2,490	22.41	32
985+00.00	992+50.00	RT	0.00		17.17	17	17	0.00		1873	1,385	12.47	39
RALSTON RD/IL 173													
992+50.00	1007+50.00	LT	2.20		211.29	211	211	2.20	2.20	20839	1,072	9.65	431
992+50.00	1007+50.00	RT	0.80		92.96	93	93	0.80	0.80	4880	1,691	15.22	101
1007+50.00	1022+50.00	LT	1.10	0.50	101.83	102	102	1.60	1.60	14303	228	2.05	296
1007+50.00	1022+50.00	RT	0.90		99.64	100	100	0.90	0.90	9385	1,504	13.54	194
1022+50.00	1035+00.00	LT	0.00		27.42	27	27	0.00		620	2,212	19.91	13
1022+50.00	1035+00.00	RT	0.10		35.00	35	35	0.10	0.10	3479	2,097	18.87	72
SMYTHE AVE.													
40+00.00	42+30.00	LT	0.00		1.43	1	1	0.00		206	115	1.04	4
40+00.00	42+30.00	RT	0.00		1.62	2	2	0.00		99	131	1.18	2
BANYAN DRIVE													
10+00.00	13+20.00	LT	0.00		6.58	7	7	0.00		682	531	4.78	14
10+00.00	13+20.00	RT	0.00		6.49	6	6	0.00		178	523	4.71	4
N. 2ND STREET													
50+00.00	64+00.00	LT	0.00		25.85	26	26	0.00		1574	2,085	18.77	33
IL 251													
858+00.00	860+00.00	LT	0.05		4.50	5	5	0.05	0.05	153	0	0.00	3
858+00.00	860+00.00	RT	0.05		4.50	5	5	0.05	0.05	69	0	0.00	1
860+00.00	875+00.00	LT	0.82		73.80	74	74	0.82	0.82	5537	0	0.00	114
860+00.00	875+00.00	RT	0.82		73.80	74	74	0.82	0.82	10529	0	0.00	218
875+00.00	883+00.00	LT	0.80		72.00	72	72	0.80	0.80	6338	0	0.00	131
875+00.00	883+00.00	RT	0.60		54.00	54	54	0.60	0.60	1968	0	0.00	41
ORLANDO													
75+00.00	80+00.00	LT	0.00		1	1	1	0.00		239	94	0.85	5
75+00.00	80+00.00	RT	0.00		2	2	2	0.00		455	198	1.78	9
N. 2ND FRONTAGE ROAD													
310+00.00	316+00.00	LT	0.00		2	2	2	0.00		312	145	1.30	6
310+00.00	316+00.00	RT	0.00		3	3	3	0.00		367	267	2.40	8
ALPINE ROAD													
259+00.00	270+00.00	LT	0.04		3	3	3	0.04	0.04	335	0	0.00	7
259+00.00	270+00.00	RT	0.21		19	19	19	0.21	0.21	1439	0	0.00	30
270+00.00	281+00.00	LT	0.06		6	6	6	0.06	0.06	582	0	0.00	12
270+00.00	281+00.00	RT	0.00		10	10	10	0.00		969	835	7.52	20
TOTAL			8.50	0.50	988	988	988	9.00	9.00	88,943	17,603	158	1,838

44000100 PAVEMENT REMOVAL				
STATION	STATION	OFFSET	AREA (SQ YD)	REMARKS
RALSTON RD				
986+81.58	995+50.00	LT/RT	3,628	
995+50.00	1002+68.09	LT/RT	5,270	
998+16.79	998+99.79	RT	677	SERVICE RD
ILLINOIS ROUTE 173				
1002+68.09	1010+50.00	LT/RT	4,982	
1010+50.00	1025+50.00	LT/RT	10,452	
1025+50.00	1028+00.00	LT/RT	1,621	
SYMTHIE AVENUE				
40+19.31	42+30.00	LT/RT	579	
N. 2ND STREET				
55+07.00	59+42.49	LT	1,823	
59+42.49	64+00.00	RT	1,193	
ILLINOIS ROUTE 251				
862+93.96	868+00.00	LT	1,360	
862+93.96	868+00.00	RT	1,709	
868+00.00	870+31.69	LT	865	
868+00.00	870+31.69	RT	1,381	
871+12.44	875+00.00	LT	2,152	
871+12.44	875+00.00	RT	1,293	
875+00.00	878+58.13	LT	1,065	
875+00.00	878+58.13	RT	942	
ORLANDO ST				
77+50.00	79+73.41	LT/RT	1,775	
N 2ND FRONTAGE RD				
310+37.89	313+90.12	LT/RT	2,300	
ALPINE RD				
262+82.70	266+00.00	RT	746	
266+00.00	269+66.13	LT/RT	3,137	
270+32.96	274+00.00	LT/RT	3,236	
274+00.00	275+06.15	LT	299	
274+00.00	275+06.15	RT	471	
TOTAL			52,956	

44004250 PAVED SHOULDER REMOVAL			
STATION	STATION	OFFSET	AREA (SQ YD)
ILLINOIS ROUTE 173			
1003+82.64	1004+93.34	RT	73
1005+16.34	1010+50.00	RT	310
1010+50.00	1011+61.65	RT	59
1013+70.22	1018+43.56	RT	310
1020+92.91	1025+50.00	RT	212
1025+50.00	1027+43.41	RT	95
1029+40.38	1032+15.27	RT	239
1004+23.95	1010+50.00	LT	270
1010+50.00	1010+91.31	LT	22
1013+31.24	1018+52.28	LT	212
1026+00.58	1027+44.87	LT	150
1029+57.73	1035+48.12	LT	326
ILLINOIS ROUTE 251			
862+93.96	868+00.00	LT	551
862+93.96	868+00.00	LT	246
862+93.96	868+00.00	RT	248
862+93.96	868+00.00	RT	438
868+00.00	870+21.96	LT	193
868+00.00	870+31.69	LT	114
868+00.00	870+31.69	RT	114
868+00.00	870+78.39	RT	146
871+12.44	875+00.00	LT	198
871+12.44	875+00.00	LT	195
871+12.44	875+00.00	RT	191
871+12.44	875+00.00	RT	338
875+00.00	878+58.13	LT	349
875+00.00	878+58.13	LT	171
875+00.00	878+58.13	RT	172
875+00.00	878+58.13	RT	371
TOTAL			6,314

44000155 HOT-MIX ASPHALT SURFACE REMOVAL, 1.5"			
STATION	STATION	OFFSET	AREA (SQ YD)
IL ROUTE 251			
862+45.00	862+93.96	LT	54
861+10.00	862+93.96	RT	204
TOTAL			259

44003100 MEDIAN REMOVAL			
STATION	STATION	OFFSET	AREA (SQ FT)
RALSTON RD			
994+40.62	995+50.00	LT/RT	723
995+50.00	997+69.35	LT/RT	2,960
998+61.94	1002+01.66	LT/RT	1,335
ALPINE RD			
262+87.52	266+00.00	RT	1,990
266+00.00	269+40.90	LT	2,133
270+66.66	272+62.91	RT	1,010
TOTAL			10,151

40300200 BITUMINOUS MATERIALS (PRIME COAT)			
	SUB-TOTAL		TON
HMA ENTRANCES	1.9		
HMA PAVEMENT	8.0		
HMA MEDIAN	3.3		
TOTAL	13.1		

40600300 AGGREGATE (PRIME COAT)			
	SUB-TOTAL		TON
HMA ENTRANCES	2		
HMA PAVEMENT	21		
TOTAL	23		

40600990 TEMPORARY RAMP				
LOCATION		STAGE 1B	STAGE 2B	
STATION TO STATION	OFFSET	SQ YD	SQ YD	
IL ROUTE 173				
1002+56.12	1003+38.08	LT	95	
1002+43.57	1003+06.35	LT/RT		184
SUB-TOTAL			95	184

40600990 TEMPORARY RAMP, TOTAL = 279 SQ YD

44000158 HMA SURFACE REMOVAL, 2.25"		
STATION	STATION	AREA (SQ YD)
275+00.00	277+80.28	2,664
TOTAL		2,664

PAVEMENT SCHEDULE

LOCATION	OFFSET	AREA	LENGTH	31100910	31100950	Z0028415	35300500	40300200	40600215	40600300	40600525	40600837	40603080	40603235	40603310	40603565	42000306	42000411	X4201000		
				SUB GRAN MAT A 12	SUB GRAN MAT A 21	GEOTECHNICAL REINF	PCC BSE CSE 10	BIT MATLS PR CT	P BIT MATLS PR CT	AGG PR CT	LEV BIND HM N50	POLYMERIZED LEV BIND MM N70	HMA BC IL-19.0	POLYMERIZED HMA BC IL-19.0 N70	HMA SC "C" N50	POLYMERIZED HMA SC "E" N70	PCC PVT 8 1/4 JOINTD	PCC PVT 9 1/2 JOINTD	HES PCC PVT 9 1/2 J		
STATION TO STATION		SQYD	LENGTH	SQYD	SQYD	SQYD	SQYD	TON	TON	TON	TON	TON	TON	TON	TON	TON	SQYD	SQYD	SQYD		
RALSTON RD/IL 173																					
986+81.58	992+50.00	LT	1066.6	568.42	1,654		1,654												1,067		
986+81.58	992+50.00	RT	1866.8	568.42	2,553		2,553												1,867		
992+50.00	993+00.00	LT	131.1	50.00	174		174												131		
992+50.00	993+00.00	RT	261.3	50.00	296		296												261		
993+00.00	1002+50.00	LT	5144.9	950.00		5,760	5,760												5,145		
993+00.00	1002+50.00	RT	6227.4	950.00		7,075	7,075												6,227		
1002+50.00	1007+50.00	LT	4519.9	500.00	4,937		4,937												4,520		
1002+50.00	1007+50.00	RT	3366.6	500.00	3,707		3,707												3,367		
1007+50.00	1021+50.00	LT	9268.5	1400.00	9,943		9,943												8,031		
1007+50.00	1021+50.00	RT	9428.5	1400.00	10,705		10,705												9,429		
1021+50.00	1022+20.19	LT	467.9	70.19		518	518												468		
1021+50.00	1022+20.19	RT	208.3	70.19		269	269												208		
1022+20.19	1022+50.00	RT/LT	276.4	29.81	318			0.4	0.4					166		25					
1022+50.00	1028+00.00	RT/LT	3751.8	550.00	4,277			5.4	5.6					2,259		335					
RUSS STREET																					
998+40	999+00	195.30 RT	177.3	92.52	220		220	0.3	0.3				65		20						
991+70	998+40	RT	1942.3					0.6	2.9		112				163						
SMYTHE AVENUE																					
41+37.92	42+30.00	RT/LT	255.4	92.08	307		307	0.4	0.4				93		29						
BANYAN DRIVE																					
10+00.00	13+20.00	RT/LT	779.5	311.66	935		935	1.1	1.2				207		87						
N. 2ND STREET																					
50+00.00	64+00.00	RT/LT	3961.9	1297.05	4,851		4,851	5.7	5.9				1054		444						
IL ROUTE 251																					
861+00.00	862+93.96	49' RT	1839.6	183.96	318		318								206						
862+45.00	862+93.96	49' LT	489.6	48.96	75		75								55						
862+93.96	869+00.00	LT	1845.1	606.04	2998.64		2,999												1,845		
862+93.96	869+00.00	RT	3888.0	606.04	4626.78		4,627												3,888		
872+00.00	878+58.13	LT	4310.5	658.13	5025.17		5,025												4,311		
872+00.00	878+58.13	RT	2174.7	658.13	3159.40		3,159												2,175		
ORLANDO																					
77+50.00	78+91.69	RT/LT	698.6	141.69	866		866										699				
N. 2ND FRONTAGE ROAD																					
311+40.14	313+90.12	LT	917.8	249.98	1,000		1,000										918				
311+40.14	313+90.12	RT	942.1	249.98	1,031		1,031										942				
ALPINE ROAD																					
259+63.78	268+49.86	RT	2886.5	886.08	3,695		3,695												2,887		
267+00.00	268+49.86	LT	599.6	149.86	724		724												600		
271+25.66	275+00.00	LT	1954.4	374.34	2,322		2,322												1,936		
271+25.66	275+00.00	RT	1421.5	374.34	1,806		1,806												1,422		
275+00.00	277+80.26	RT/LT	2659.3	280.26					0.8	4.0		153			237						
275+00.00	275+06.15	RT/LT	8.1	6.15	8		8	8	0.00	0.01					1						
275+00.00	275+14.36	27' RT	27.0	14.36	27		27	27	0.01	0.04											
275+74.47	277+35.86	24' RT	49.3	161.39	105		105	49	0.01	0.1											
TOTAL					72,665		13,622	81,692	84	8	7	21	112	153	1,419	2,425	1,004	598	2,559	59,782	1,238

SCHEDULE OF QUANTITIES

STATION	REMARKS	EXISTING SURFACE TYPE (FLARE/APRON)	TOTAL AREA	FLARE	APRON	FOR TEMP ACC		40201000	35102000	40300200	40600300	40800050	42300300
						FLARE	APRON	AGG.-TEMP ACCESS	AGG BSE CSE B 8"	BIT MATLS PR CT	AGG PR CT	2" INC HMA SURF	PCC DRIVEWAY 7"
			SQ YD	SQ YD	SQ YD	SQ YD	SQ YD	TON	SQ YD	TON	TON	TON	SQ YD
RALSTON ROAD													
988+28.34	RT	CONC/BIT	115.5	83.5	32.0	86.7	35.5	32	35	0.05	0.1	4.5	84
990+40.10	LT	CONC/BIT	154.9	67.9	87.0	68.9	88.1	42	96	0.1	0.1	12.2	68
991+01.65	LT	CONC/BIT	138.2	83.3	54.9	87.6	55.0	38	60	0.1	0.1	7.7	83
SMYTHE AVENUE													
41+15.89	RT	CONC/BIT	91.5	65.6	25.9	67.7	28.9	25	29	0.04	0.1	3.6	66
MAILBOX	LT	BIT	43.1							0.1	0.1	6.0	
BANYAN DR													
11+21.93	RT	CONC/BIT	319.4	112.6	206.8	115.1	216.8		227	0.3	0.2	28.9	113
N. 2ND STREET													
51+50.00	LT	BIT	372.3						410	0.5	0.6	52.1	
54+26.59	LT	CONC	147.5										147
55+92.57	LT	CONC/BIT	127.7	78.6	49.1	80.9	53.4		54	0.1	0.1	6.9	79
57+60.81	LT	CONC/BIT	148.5	84.6	63.8	86.9	63.8		70	0.1	0.1	8.9	85
MAILBOX	LT	CONC	22.6										23
59+82.68	LT	CONC/BIT	117.2	83.5	33.7	85.8	34.0		37	0.05	0.1	4.7	83
62+79.95	LT	CONC/BIT	95.7	83.5	12.2	85.8	15.0		13	0.02	0.1	1.7	83
63+53.05	LT	NO CHANGE											
ORLANDO ST													
76+31.83	RT	BIT	15.8						17	0.02	0.02	2.2	
76+80.04	RT	BIT	27.3						30	0.04	0.04	3.8	
77+77.93	RT	BIT	36.7						40	0.1	0.1	5.1	
ALPINE													
262+39.73	RT	BIT	92.9					25	102	0.1	0.1	13.0	
270+81.00	RT	BIT (PARKING LOT)	52.3						58	0.1	0.1	7.3	
272+44.46	RT	BIT	95.2						105	0.1	0.1	13.3	
TOTAL=								162	1,384	1.9	2	182	913

44000200 DRIVEWAY PAVEMENT REMOVAL		
STATION	OFFSET	AREA (SQ YD)
RALSTON RD		
993+05.79	LT	74
995+12.63	RT	80
996+00.81	LT	719
996+64.52	RT	56
ILLINOIS ROUTE 173		
1016+92.19	RT	59
1017+87.59	RT	43
ORLANDO STREET		
76+28.98	RT	12
76+77.52	RT	27
77+77.51	RT	42
ALPINE RD		
262+42.12	RT	136
272+29.46	RT	122
TOTAL		1,370

44004000 PAVED DITCH REMOVAL			
STATION	STATION	OFFSET	LENGTH (FT)
P N SECOND STREET			
52+74.78	54+30.41	LT	216
54+80	55+22.67	RT	49
ILLINOIS ROUTE 251			
864+34	864+84	RT	50
871+95	873+86	LT	192
874+00	874+15	LT	16
TOTAL			523

48300410 PORTLAND CEMENT CONCRETE SHOULDERS 9 1/2"				
STATION TO STATION	OFFSET	LENGTH	AREA	
			LF	SQ YD
IL ROUTE 251				
862+93.96	TO 869+23.15	73.0' RT	629.19	416
862+93.96	TO 869+26.09	68.63' LT	632.13	837
862+93.93	TO 869+94.72	RT/LT		623
871+53.67	TO 875+00	RT/LT		308
871+79.29	TO 875+00	71' RT	320.71	343
871+79.29	TO 875+00	77.5' LT	283.98	135
875+00.00	TO 878+58.13	49' RT	358.13	398
875+00.00	TO 878+58.13	RT/LT		319
875+00.00	TO 878+58.13	49' LT	358.13	216
TOTAL				3,594

50102400 CONCRETE REMOVAL						
STATION	STATION	OFFSET	AREA	THICKNESS (4")	VOLUME	VOLUME
			(SQ FT)	FT	(CF)	(CY)
IL ROUTE 173						
1018+00.00	1019+03.00	LT	4,450.00	0.33	1481.85	55
TOTAL						55

44000500 COMBINATION CURB AND GUTTER REMOVAL				
STATION	STATION	OFFSET	LENGTH (FT)	REMARKS
RALSTON RD				
985+19.20	995+50.00	LT	1182	
985+50.57	995+50.00	RT	557	
990+54.55	995+50.00	RT	480	
995+50.00	996+55.25	LT	138	
996+55.25	997+63.71	LT	112	
997+63.71	1002+68.09	LT	165	
995+50.00	997+65.41	RT	220	
998+68.44	1002+68.09	RT	295	
980+50.00	995+50.00	RT	290	BANK DRIVEWAY
980+50.00	995+50.00	LT	300	BANK DRIVEWAY
995+50.00	1002+68.09	RT	190	SERVICE RD
995+50.00	1002+68.09	LT	221	SERVICE RD
ILLINOIS ROUTE 173				
1029+03.83	1029+40.38	RT	40	
1027+44.87	1028+02.68	LT	82	
1029+57.73	1029+14.36	LT	44	
N. 2ND STREET				
53+99.45	54+53.95	LT	55	
55+11.12	59+42.16	RT	861	
55+11.12	59+42.16	LT	662	
ILLINOIS ROUTE 251				
875+00.00	878+58.13	LT	222	
875+00.00	878+58.13	RT	220	
N. 2ND FRONTAGE RD				
314+46.83	315+16.46	RT	71	
310+39.27	313+90.12	RT	404	
311+82.52	313+69.85	RT	222	
310+41.41	313+90.12	LT	426	
ORLANDO STREET				
77+00.50	79+47.32	LT	264	
76+93.77	79+58.31	RT	480	
75+90.84	76+93.77	RT	120	
ALPINE RD				
270+40.33	274+00.00	LT	388	
272+62.91	274+00.00	LT/RT	275	
270+32.53	272+50.01	RT	296	
270+68.29	271+33.39	RT	123	PARKING LOT
272+67.36	274+00.00	RT	228	
269+56.15	266+62.41	LT	343	
266+00.00	269+67.62	RT	398	
259+54.09	262+97.53	RT	296	
262+97.53	266+00.00	RT	454	
274+00.00	275+63.45	LT	164	
274+00.00	275+06.15	LT/RT	208	
274+00.00	275+00.00	RT	106	
275+00.00	277+80.28	RT	224	
CONTINENTAL DRIVE				
89+62.58	88+25.52	RT	175	
TOTAL			12,001	

48203021 HOT-MIX ASPHALT SHOULDERS, 6"			
STATION TO STATION	OFFSET	LENGTH	AREA
		LF	SQ YD
IL ROUTE 251			
861+00.00	TO 862+93.96	59' RT	193.96
862+45.00	TO 862+93.96	59' LT	48.96
TOTAL			115

50100300 REMOVAL OF EXISTING STRUCTURES NO. 1		
LOCATION	STATION	EACH
ILLINOIS ROUTE 173	1009+60	1
TOTAL		1

50100400 REMOVAL OF EXISTING STRUCTURES NO. 2		
LOCATION	STATION	EACH
N. 2ND FRONTAGE RD	311+09	1
TOTAL		1

50104400 CONCRETE HEADWALL REMOVAL			
LOCATION	STATION	OFFSET	EACH
ILLINOIS ROUTE 173	1020+70.77	47.7 LT	1
ILLINOIS ROUTE 173	1020+70.21	42.5 RT	1
TOTAL			2

60600095 CLASS SI CONCRETE (OUTLET)		
LOCATION	OFFSET	VOLUME
		CU YD
SMYTHE AVE.		
41+37.92	13' LT	1.2
41+68.11	13.71' RT	1.2
N. 2ND STREET		
63+88.00	12.0' LT	1.2
66+88.00	11.5' RT	1.2
IL ROUTE 251		
868+81.09	84' LT	5.5
868+96.47	89' RT	4.3
TOTAL		15

FILE NAME = 0264987-shd-sched.lie-01.dgn

USER NAME = 3202090971
 PLOT SCALE =
 PLOT DATE = 3/16/2011

DESIGNED - LOM
 DRAWN - MD
 CHECKED - PDK
 DATE - 03-16-2011

REVISED -
 REVISED -
 REVISED -
 REVISED -

**STATE OF ILLINOIS
 DEPARTMENT OF TRANSPORTATION**

SCHEDULE OF QUANTITIES

SCALE: SHEET NO. OF SHEETS STA. TO STA.

F.A.P. RTE.	SECTION	COUNTY	TOTAL SHEETS	SHEET NO.
303	129K-1	WINNEBAGO	401	30
CONTRACT NO. 64987				
FED. ROAD DIST. NO. 2 ILLINOIS FED. AID PROJECT				

DRAINAGE SCHEDULE

PAY ITEM NUMBER			20800150	550A0050	550A0340	Z0056648	Z0056668	550A0070	550A0360	550A0090	550A0380	550A0110	550A0400	550A0120	550A0410	Z0056672	550A0140	550A0430	550A0160	550A0450	550A0480			
SHEET	STRUCTURE TO FROM		TRENCH BACKFILL CU YD	12"				15"		18"		21"		24"		30"		36"		48"	STRUCTURE TO FROM			
				CLASS A		W-M		CLASS A		CLASS A		CLASS A		W-M	CLASS A		CLASS A		CLASS A					
				TYPE 1 FEET	TYPE 2 FEET	TYPE 1 FEET	TYPE 2 FEET	TYPE 1 FEET	TYPE 2 FEET	TYPE 1 FEET	TYPE 2 FEET	TYPE 1 FEET	TYPE 2 FEET	TYPE 1 FEET	TYPE 2 FEET	TYPE 2 FEET	TYPE 1 FEET	TYPE 2 FEET	TYPE 1 FEET	TYPE 2 FEET			TYPE 2 FEET	
D3	100	101	0																			40	100	101
D3	101	102	302.2																			184	101	102
D3	102	103	106.7																	71			102	103
D3	103	104	67.26																	46			103	104
D3	104	105	0															25					104	105
D3	105	124	0						51														105	124
D3	102	106	337.89																			192	102	106
D4	106	107	85.66		100																		106	107
D4	106	108	274.37																			191	106	108
D4	108	109	0		9																		108	109
D4	109	110	47.18		71																		109	110
D4	108	111	0																			191	108	111
D4	111	112	0									21											111	112
D4	112	113	20.85					52															112	113
D9	101	115	151.22															118					101	115
D9	115	116	32.25		45																		115	116
D9	115	123	78.74										75										115	123
D9	123	117	83.06											103									123	117
D9	117	118	16.55					44															117	118
D9	118	119	19.27	67																			118	119
D9	117	120	29.76				93																117	120
D9	120	121	31.86	111																			120	121
D4	106	122	0		6																		106	122
D4	111	A26	14.16							125													114	A7
D10	200	201	0						10														200	201
D10	201	202	44.73						61														201	202
D10	202	203	25.68					38															202	203
D9	203	204	37.21			111																	203	204
D10	203	205	43.99			137																	203	205
D3	300	301	0		11																		300	301
D3	400	401	0					42															400	401
D3	401	402	49.74		60																		401	402
D3	402	403	37.77	53																			402	403
D3	403	404	0	47																			403	404
D3	500	501	0	42																			500	501
D3	501	502	56.46		71																		501	502

DRAINAGE SCHEDULE

PAY ITEM NUMBER		20800150	550A0050	550A0340	Z0056648	Z0056668	550A0070	550A0360	550A0090	550A0380	550A0110	550A0400	550A0120	550A0410	Z0056672	550A0140	550A0430	550A0160	550A0450	550A0480			
		12"				15"		18"		21"		24"		30"		36"		48"					
		TRENCH	CLASS A		W-M		CLASS A		CLASS A		CLASS A		CLASS A		W-M	CLASS A		CLASS A		CLASS A			
SHEET	TO	FROM	BACKFILL	TYPE 1	TYPE 2	TYPE 1	TYPE 2	TYPE 1	TYPE 2	TYPE 1	TYPE 2	TYPE 1	TYPE 2	TYPE 1	TYPE 2	TYPE 2	TYPE 1	TYPE 2	TYPE 1	TYPE 2	TYPE 2	TO	FROM
D3	502	503	25.72		40																	502	503
D3	A4	601	103.76										126									A4	601
D3	601	602	49.34										73									601	602
D3	602	A5	44.36										115									602	A5
D3	A5	603	17.81					61														A5	603
D3	700	703	0	46																		700	701
D3	703	702	183	247																		701	702
D3	703	701	0	28																		703	701
D2	800	801	0										87									800	801
D2	801	802	38.16											36								801	802
D2	802	803	60.68										80									802	803
D2	803	804	0						53													803	804
D5	900	901	0														53					900	901
D5	901	902	38.79											51								901	902
D5	902	903	25.8										35									902	903
D5	903	904	0								105											903	904
D5	904	905	19.6						59													904	905
D5	904	906	0					177														904	906
D5	906	907	7.97	33																		906	907
D2	901	908	162.94														225					901	908
D2	908	909	12.5		38																	908	909
D2	909	910	15.01	51																		909	910
D2	908	911	0										210									908	911
D1	911	912	10.54		30																	911	912
D1	912	913	19.97	67																		912	913
D1	913	914	17.82	77																		913	914
D1	911	915	147.07									226										911	915
D1	915	916	12.59	45																		915	916
D1	915	917	165.24										227									915	917
D1	917	918	24.93										31									917	918
D1	918	A6	0										107									918	A6
D1	918	919	0		70																	918	919
D5	907	920	0	17																		907	920
D5	905	921	0	23																		905	921
D2	1000	1001	0					46														1000	1001

DRAINAGE SCHEDULE

PAY ITEM NUMBER			20800150	550A0050	550A0340	Z0056648	Z0056668	550A0070	550A0360	550A0090	550A0380	550A0110	550A0400	550A0120	550A0410	Z0056672	550A0140	550A0430	550A0160	550A0450	550A0480		
			12"				15"		18"		21"		24"		30"		36"		48"				
			TRENCH	CLASS A		W-M		CLASS A		CLASS A		CLASS A		CLASS A		W-M	CLASS A		CLASS A		CLASS A		
SHEET	TO	FROM	BACKFILL	TYPE 1	TYPE 2	TYPE 1	TYPE 2	TYPE 1	TYPE 2	TYPE 1	TYPE 2	TYPE 1	TYPE 2	TYPE 1	TYPE 2	TYPE 2	TYPE 1	TYPE 2	TYPE 1	TYPE 2	TYPE 2	TO	FROM
D2	1001	1002	14.84						44													1001	1002
D2	1002	1003	13.82						44													1002	1003
D2	1100	1101	0						47													1100	1101
D2	1101	1102	12.58		39																	1101	1102
D2	1102	1103	18.35	63																		1102	1103
D2	1103	1104	0	29																		1103	1104
D6	1200	1201	0						78													1200	1201
D6	1201	1202	14.48						51													1201	1202
D6	1202	1203	21.8	86																		1202	1203
D6	1203	1204	6.29	26																		1203	1204
D6	1202	1205	0	32																		1202	1205
D6	1300	1301	0						18													1300	1301
D6	1301	1302	8.2						30													1301	1302
D6	1302	1303	0	31																		1302	1303
D6	1400	1401	0	20																		1400	1401
D6	1401	1402	7.31	30																		1401	1402
D6	1402	1403	0	19																		1402	1403
D6	1500	1501	0	22																		1500	1501
D6	1501	1502	7.51	30																		1501	1502
D6	1501	1503	52.05	202																		1501	1503
D6	1503	1504	7.31	30																		1503	1504
D6	1503	1505	55.28	227																		1503	1505
D6	1505	1506	7.29	30																		1505	1506
D6	1502	1507	0	33																		1502	1507
D3	1600	1601	3.51		9																	1600	1601
D3	1601	1602	13.65	43																		1601	1602
D6	1700	1701	39.6						76													1700	1701
D7	1800	1801	0	43																		1800	1801
D7	1900	1901	0						43													1900	1901
D7	2000	2001	17.85						119													2000	2001
D3	2201	2200	0												107							2201	2200
D3	2300	2301	0												46							2300	2301
D3	2501	2500	0							25												2501	2500
TOTAL			3519.88	1950	599	248	93	914	157	198	125	331	700	565	162	103	278	118	25	117	798		

DRAINAGE SCHEDULE

PAY ITEM NUMBER				X6024246	X6024250	X6024254	X6024256	Z0019500	60236200	60236800	60240215	60240310	60218400	60219300	60221700	60223700	60224446	60224449	54213657	54213660	54213663	54213669	54213675	54213681	Z0065753					
				INLETS AND MANHOLES													FLARED END SECTIONS													
SHEET	DESC.	STATION	OFFSET	INLETS SPL N3	INLETS SPL N5	INLETS SPL N7	INLETS SPL N8	DRYWELL	INLETS TA T8G	INLETS TA T11F&G	INLETS TB T1F CL	INLETS TB T11F&G	MAN TA 4 DIA T1F CL	MAN TA 4 DIA T11F&G	MAN TA 5 DIA T8G	MAN TA 6 DIA T1F OL	MAN TA 7 DIA T1F CL	MAN TA 7 DIA T24F&G	PRC FLAR END SEC 12	PRC FLAR END SEC 15	PRC FLAR END SEC 18	PRC FLAR END SEC 24	PRC FLAR END SEC 30	PRC FLAR END SEC 36	SLOTTED DRAIN 15" WITH 6" SLOT FEET	OTHER	RIM ELEV	INVERT ELEV	DESC.	
D3	100	1018+49.65	98.58' LT																								48" PIPE INTO WALL		728.06 NW	100
D3	101	1018+91.21	74.18' LT															1										736.69	728.15 E & NW, 729.34 S	101
D3	102	1020+72.47	57.69' LT				1																					737.72	728.59 E & W, 729.00 S	102
D3	103	1020+72.49	9.05' RT											1														738.59	729.25 N & S	103
D3	104	1020+72.07	55.32' RT		1																							737.77	729.41 N & SE	104
D3	105	1020+72.82	82.50' RT												1													733.80	729.49 N, 730.99 E	105
D4	106	1022+64.49	54.00' LT			1																						738.40	729.05 E & W, 732.05 S, 733.20 N	106
D4	107	1022+62.42	42.00' RT		1																							738.67	732.57 N	107
D4	108	1024+55.64	47.74' LT													1												736.34	729.44 E & W, 732.44 S	108
D4	109	1024+55.14	34.87' LT		1																							738.48	732.87 N & S	109
D4	110	1024+53.62	33.35' RT		1																							738.49	734.49 N	110
D4	111	1026+46.40	45.00' LT														1											737.20	730.15 E & W, 732.40 S	111
D4	112	1026+45.88	21.40' LT		1																							737.62	732.54 N, 733.04 S	112
D4	113	1026+44.82	26.27' RT		1																							737.52	733.27 N	113
D9	115	1018+83.38	42.07' RT										1															737.28	729.52 N, 730.02 S, 731.02 W	115
D9	116	1018+41.14	59.37' RT		1																							737.10	733.10 NE	116
D9	117	267+82.15	46.00' LT		1																							735.23	730.36 NW, 731.11 E, 731.36 S	117
D9	118	267+82.15	2.5' LT									1																736.01	731.73 W, 731.98 E	118
D9	119	267+82.11	60.00' RT		1																							735.23	732.28 W	119
D9	120	266+89.04	46.00' LT		1																							735.63	731.90 E & N	120
D9	121	266+89.10	60.00' RT		1																							735.63	732.39 W	121
D4	122	1022+56.28	61.49' LT						1																			736.44	733.44 S	122
D9	123	268+84.23	56.46' LT										1															736.10	730.16 N & S	123
D3	124	1021+24.00	84.17' RT																			1							732.80 E	124
D3	200	272+98.02	59.25' LT																								15" PIPE INTO WALL		729.29 W	200
D3	201	2073+03.95	46.84' LT		1																							735.07	730.07 E, 729.82 W	201
D3	202	273+05.90	14.38' RT									1																735.78	730.53 W & E	202
D3	203	273+06.64	47.67' RT		1																							735.14	730.81 W, 731.06 N & S	203
D9	204	271+95.30	50.94' RT		1																							735.70	731.89 N	204
D10	205	274+43.84	47.11' RT		1																							735.63	732.09 S	205
D3	300	1011+25.95	79.15' LT																								12" PIPE INTO WALL		730.20	300
D3	301	1011+31.43	70.91' LT		1																							734.50	730.50 NW	301
D3	400	1015+99.17	99.12' LT																	1									728.33	400
D3	401	1015+98.42	53.86' LT		1																							736.38	730.15 N & S	401
D3	402	1015+97.62	5.71' RT									1																737.28	731.61 N & S	402
D3	403	1015+96.99	53.87' RT		1																							736.37	731.84 N & S	403
D3	404	1015+96.53	102.64' RT																	1									732.05	404
D3	500	1013+44.80	82.05' LT																								18" PIPE INTO WALL		727.33 N	500
D3	501	1013+44.15	56.61' LT		1																							735.54	729.64 N & S	501
D3	502	1013+44.16	9.58' RT									1																736.40	731.06 N & S	502
D3	503	1013+44.15	49.55' RT		1																							735.74	731.74 N	503

DRAINAGE SCHEDULE

PAY ITEM NUMBER				X6024246	X6024250	X6024254	X6024256	Z0019500	60236200	60236800	60240215	60240310	60218400	60219300	60221700	60223700	60224446	60224449	54213657	54213660	54213663	54213669	54213675	54213681	Z0065753						
				INLETS AND MANHOLES													FLARED END SECTIONS														
SHEET	DESC.	STATION	OFFSET	INLETS SPL N3	INLETS SPL N5	INLETS SPL N7	INLETS SPL N8	DRYWELL	INLETS TA T8G	INLETS TA T11F&G	INLETS TB T1F CL	INLETS TB T11F&G	MAN TA 4 DIA T1F CL	MAN TA 4 DIA T11F&G	MAN TA 5 DIA T8G	MAN TA 6 DIA T1F OL	MAN TA 7 DIA T1F CL	MAN TA 7 DIA T24F&G	PRC FLAR END SEC 12	PRC FLAR END SEC 15	PRC FLAR END SEC 18	PRC FLAR END SEC 24	PRC FLAR END SEC 30	PRC FLAR END SEC 36	SLOTTED DRAIN 15" WITH 6" SLOT FEET	OTHER	RIM ELEV	INVERT ELEV	DESC.		
D3	601	312+50.00	34.00' LT		1																							733.36	728.40 S & E	601	
D3	602	312+50.00	34.00' RT		1																							733.36	728.83 W & N	602	
D3	603	313+45.71	34.39' LT		1																							733.23	730.15 E	603	
D3	700	1010+94.05	54.00' RT																							12" PIPE INTO WALL		725.11		700	
D3	701	1008+53.88	52.46' RT		1																							733.82	729.42 S	701	
D3	702	1008+17.86	77.85' RT		1																							734.83	730.83 W	702	
D3	703	1008+55.03	82.90' RT										1															731.16	726.49 W, 728.16 E & N	703	
D2	800	1005+90.52	66.00' LT																		1								725.25		800
D2	801	1005+90.51	9.00' RT		1																							732.67	726.12 S & N	801	
D2	802	1005+90.49	45.26' RT											1														733.23	726.48 N & S	802	
D2	803	1006+15.48	131.17' RT		1																							732.16	728.07 S, 728.57 N	803	
D2	804	1005+50.00	101.90' LT																			1							730.25		804
D5	900	995+80.00	103.00' LT																				1						727.48		900
D5	901	995+80.00	42.00' LT	1																								732.57	727.57	901	
D5	902	995+80.00	9.00' RT											1														733.05	727.69	902	
D5	903	995+80.00	43.39' RT		1																							732.53	727.76 N, 728.01 W	903	
D5	904	994+79.94	75.20' RT		1																							732.62	728.28 E, 728.53 W, 728.72 S	904	
D5	905	994+21.34	75.20' RT		1																							732.53	729.03	905	
D5	906	10+55.00	17.17' RT		1																							732.76	729.41 N, 729.66 W	906	
D5	907	10+55.00	15.08' LT		1																							732.81	729.81	907	
D2	908	993+55.00	46.84' LT	1																								733.77	728.61 E, 730.11 S, 729.11 W	908	
D2	909	993+55.00	9.00' LT							1																		734.39	730.28 N & S	909	
D2	910	993+55.00	42.00' RT		1																							733.50	730.5	910	
D1	911	991+45.18	35.00' LT		1																							735.23	730.33 E, 731.33 S, 730.58 W	911	
D1	912	991+46.00	5.29' LT									1																735.76	731.46	912	
D1	913	41+01.22	43.43' LT	1																								734.67	731.76	913	
D1	914	40+61.41	22.11' RT	1																								735.10	732.1	914	
D1	915	989+21.00	24.39' LT		1																							736.63	732.05 E & W, 732.80 S	915	
D1	916	989+21.00	20.68' RT		1																							736.75	733.75	916	
D1	917	986+96.00	15.05' LT		1																							738.06	732.61	917	
D1	918	986+96.00	15.58' RT		1																							738.06	732.69 N & W, 734.18 SE	918	
D1	919	987+60.45	43.5' RT						1																			736.30	733.5	919	
D5	920	10+50.00	31.5' LT																1										730.35		920
D5	921	12+30.16	49.07' LT																1										730.98		921
D2	1000	997+50.01	97.88' LT																			1							727.9		1000
D2	1001	997+51.33	42.07' LT		1																							731.75	728.1	1001	
D2	1002	997+51.33	1.68' RT									1																732.34	728.26	1002	
D2	1003	997+51.33	45.15' RT		1																							731.67	728.42	1003	
D2	1100	999+74.77	99.73' LT																			1							728.38		1100
D2	1101	999+76.00	47.81' LT		1																							732.41	728.56 N, 728.81 S	1101	
D2	1102	999+76.00	9.00' LT									1																733.04	728.99	1102	
D2	1103	999+76.00	54.00' RT		1																							732.26	729.26 NE, 729.46 SW	1103	
D2	1104	999+75.00	85.00' RT																	1									729.26		1104
D2	1105	999+75.00	87.00' RT					1																				726.26		1105	

SCHEDULE OF QUANTITIES

PAY ITEM NUMBER		50105220	60500040	60500060	X0322936
STATION	OFFSET	PIPE CULVERT REMOV FOOT	REMOV MANHOLES EACH	REMOV INLETS EACH	REMOV EX FLAR END SEC EACH
986+68.28	RT	158			
987+48.17	21.34' RT		1		
987+48.28	RT	7			
987+48.26	14.68' RT			1	
987+48.21	CROSS	29			
987+48.01	14.45' LT			1	
988+45.43	RT	193			
989+42.80	23.87' RT		1		
989+42.74	RT	10			
989+43.32	14.42' RT			1	
989+43.21	CROSS	29			
989+43.11	14.56' LT			1	
989+94.59	RT	104			
990+46.65	22.14' RT			1	
990+61.97	RT	31			
991+15.85	21.88' RT			1	
991+28.88	CROSS	45			
991+41.94	14.98' LT			1	
992+29.32	RT	227			
993+42.80	31.94' RT		1		
993+43.59	RT	8			
993+44.55	24.95' RT			1	
993+43.45	CROSS	45			
993+42.28	20.54' LT			1	
994+43.63	RT	202			
995+44.46	41.08' RT		1		
995+44.33	RT	9			
995+44.30	32.40' RT			1	
995+43.15	CROSS	63			
995+42.02	31.73' LT			1	
995+41.02	LT	27			
995+40.21	60.87' LT				
996+43.89	RT	199			
997+43.31	42.02' RT		1		
997+44.53	RT	8			
997+45.75	34.62' RT			1	
997+53.90	CROSS	71			
997+62.05	34.72' LT			1	
997+56.86	LT	35			
997+50.51	71.38' LT				
998+32.94	149.69' RT			1	
998+23.82	RT	30			
998+97.51	RT	106			
999+44.00	39.93' RT		1		
999+43.93	RT	6			
999+43.85	34.61' RT			1	
999+43.39	CROSS	69			
999+42.93	34.62' LT			1	
999+75.91	LT	69			

PAY ITEM NUMBER		50105220	60500040	60500060	X0322936
STATION	OFFSET	PIPE CULVERT REMOV FOOT	REMOV MANHOLES EACH	REMOV INLETS EACH	REMOV EX FLAR END SEC EACH
1000+08.89	55.82' LT			1	
52+37.72	44.24' RT			1	
52+47.32	CROSS	23			
52+57.16	31.62' RT			1	
52+64.78	RT	16			
52+74.77	29.48' RT				
54+28.93	47.92' LT			1	
54+29.21	CROSS	65			
54+29.38	18.95' RT				
54+33.21	21.71' RT				
54+56.50	CROSS	53			
54+79.91	10.08' LT				
998+27.29	91.74' LT			1	
998+53.09	LT	52			
998+78.88	90.01' LT			1	
998+62.21	64.71' LT			1	
55+87.53	LT	49			
56+90.25	36.76' LT				
56+90.10	LT	22			
56+89.96	14.45' LT			1	
56+89.86	CROSS	29			
56+89.76	14.73' RT				
56+89.69	RT	23			
56+89.62	38.48' RT				
871+92.73	76.27' LT				
871+92.97	LT	73			
871+92.80	3.03' LT				
1009+10.55	91.22' RT				1
1009+98.58	62.59' LT				1
311+68.34	LT	53			
311+94.50	23.89' LT			1	
311+94.00	CROSS	48			
311+93.50	23.97' RT			1	
312+76.21	RT	172			
313+46.18	25.14' LT			1	
313+52.27	CROSS	52			
1013+56.85	RT	105			
1014+07.59	44.72' RT			1	
267+58.91	46.68' LT			1	
267+98.38	LT	80			
268+38.56	37.07' LT			1	
268+37.17	CROSS	88			
268+36.39	50.37' RT			1	
268+47.70	RT	23			
268+58.99	49.47' RT		1		
268+81.27	RT	51			
269+05.15	74.32' RT				
270+60.72	85.32' RT				

PAY ITEM NUMBER		50105220	60500040	60500060	X0322936
STATION	OFFSET	PIPE CULVERT REMOV FOOT	REMOV MANHOLES EACH	REMOV INLETS EACH	REMOV EX FLAR END SEC EACH
270+65.86	85.40' RT				
270+66.60	CROSS	79			
270+66.60	CROSS	79			
270+70.37	CROSS	96			
272+15.72	LT	7			
272+16.06	51.79' LT			1	
272+15.96	CROSS	54			
272+15.86	1.94' RT			1	
272+28.80	CROSS	38			
272+41.74	30.65' RT			1	
273+40.32	RT	198			
274+38.90	40.86' RT			1	
1020+66.29	CROSS	92			
1020+69.07	CROSS	92			
1020+74.66	CROSS	92			
1027+44.96	34.74' LT				1
1027+56.78	LT	26			
TOTAL		3710	7	35	3

PAY ITEM NUMBER		60255500	60260100						
DESC.	STATION	OFFSET	MAN ADJUST EACH	INLETS ADJUST EACH	STRUCTURE TYPE	EX RIM ELEV	PROP RIM ELEV	PROP INVERT	COMMENTS
A1	78+52.18	26.88' LT		1	SPL INLET NO. 5	734.22	734.55	N/A	
A2	78+51.29	17.94' LT	1		DRAINAGE	734.36	734.69	N/A	
A3	78+51.30	24.04' RT		1	SPL INLET NO. 5	734.4	734.65	N/A	
A4	311+42.18	34.04' LT	1		DRAINAGE	733.05	733.85	727.79 N	
A5	313+57.71	25.30' RT	1		DRAINAGE	733.34	733.41	729.54 W & S	
A6	985+88.41	20.87' RT	1		DRAINAGE	739.30	N/A	732.96 E	
A14	79+22.95	77.44' RT	1		DRAINAGE	736.26	735.52	N/A	
A19	264+85.50	39.07' RT	1		DRAINAGE	736.71	736.39	N/A	
A20	261+86.52	32.23' RT		1	SPL INLET NO. 5	736.16	736.02	MATCH EX	MOVE W/ 5' NEW PIPE
A21	259+85.36	30.71' RT		1	SPL INLET NO. 5	736.52	736.54	MATCH EX	MOVE W/ 1' NEW PIPE
A25	276+15.16	26.11' RT		1	INLET TYPE A	735.73	735.93	MATCH EX	MOVE W/ 5' NEW PIPE
A26	1027+68.85	24.12' LT	1		DRAINAGE	737.85	737.77	MATCH EX	
A27	1020+88.00	66.00' LT		1	DRAINAGE	735.80	735.90	MATCH EX	
TOTAL			7	6					

FILE NAME = 0264987-shr-schedule-01.dgn

USER NAME = 328289971

DESIGNED - LOM
DRAWN - MD

REVISOR -
REVISION -

PLOT SCALE =
PLOT DATE = 3/25/2011

CHECKED - PDK
DATE - 03-16-2011

REVISOR -
REVISION -

**STATE OF ILLINOIS
DEPARTMENT OF TRANSPORTATION**

SCHEDULE OF QUANTITIES

SCALE: SHEET NO. OF SHEETS STA. TO STA.

F.A.P. RTE.	SECTION	COUNTY	TOTAL SHEETS	SHEET NO.
303	129K-1	WINNEBAGO	401	37
CONTRACT NO. 64987				

FED. ROAD DIST. NO. 2 ILLINOIS FED. AID PROJECT

ADJUSTING SERVICE LINES SCHEDULE

PAY ITEM NUMBER		56500600	60265700	60266600	60266100	56400100		
LOCATION		DOM WAT SER BOX ADJ	VV ADJUST	VALVE BOX ADJ	VV RECONST	FIRE HYDNTS TO BE MVD	COMMENTS	ROW
STATION	OFFSET	EACH	EACH	EACH	EACH	EACH		
59+69.59	11.15' RT	1						EX
271+06.47	56.19' RT			1			HYDRANT AUXILIARY VALVE	PR
271+06.48	57.32' RT					1	REUSE EXISTING HYDRANT	PR
272+33.68	53.55' RT			1			MAIN LINE VALVE	EX
272+38.17	85.38' RT			1			HYDRANT AUXILIARY VALVE	PR
274+40.65	50.21' RT			1			MAIN LINE VALVE	EX
274+93.47	51.40' RT			1			MAIN LINE VALVE	EX
276+88.88	37.35' RT			1			HYDRANT AUXILIARY VALVE	PR
312+44.11	31.09' LT			1		1	REUSE EXISTING HYDRANT	EX
312+46.94	29.07' LT			1			HYDRANT AUXILIARY VALVE	EX
313+00.28	25.37' LT	1						EX
868+85.84	101.64' RT		1					EX
869+70.04	106.67' RT		1					EX
867+91.41	109.19' RT			1			MAIN LINE VALVE	EX
868+03.73	103.71' RT			1			MAIN LINE VALVE	EX
997+97.59	73.33' LT			1			MAIN LINE VALVE	EX
1000+84.38	49.58' LT			1			MAIN LINE VALVE	EX
1009+57.54	61.49' RT				1		MAIN LINE VALVE	EX
1009+62.16	75.82' RT			1			MAIN LINE VALVE	EX
1009+95.41	77.26' RT			1			MAIN LINE VALVE	EX
1019+13.73	30.07' RT			1			MAIN LINE VALVE	EX
1020+37.04	54.63' LT				1			EX
1021+00.09	54.58' LT				1			EX
TOTAL		2	2	14	3	2		EX

PAY ITEM NUMBER		*Z0077002	
LOCATION		WATER MAIN REMOVAL	
STATION	OFFSET	REMOVAL FOOT	COMMENTS
TO	FROM		
268+50	269+75	LT	125
TOTAL		125	EX ROW

PAY ITEM NUMBER		X6022820					
DESC.	STATION	OFFSET	MAN SAN 5 DIA T1F CL	STRUCTURE TYPE	PROP RIM ELEV	INVERT ELEV	COMMENTS
2401	1006+81.43	75.78' RT	1	SANITARY	731.05	717.12	EX ROW

PAY ITEM NUMBER		56400820	X0324449	X0323841	56105000	
LOCATION		FIRE HYD W/AUX V & VB	D I WT MNF MU 8X6 HTEE	WM LINE STOP 8	WATER VALVES 8	COMMENTS
STATION	OFFSET	EACH	EACH	EACH	EACH	
58+02.42	76.49' RT			1		EX ROW
58+22.42	64.54' RT				1	EX ROW
60+73.87	19.00' LT	1				EX ROW
268+88.20	47.50' LT		1			EX ROW
268+88.20	62.00' LT	1				PR ROW
TOTAL		2	1	1	1	

PAY ITEM NUMBER		56100700	
LOCATION		WATER MAIN 8	
STATION	OFFSET	FOOT	COMMENTS
TO	FROM		
268+50	269+75	LT	125
TOTAL		125	PVC/ EX ROW

PAY ITEM NUMBER		*56400810	
LOCATION		FIRE HYDRANT EXTEN	
STATION	OFFSET	FOOT	COMMENTS
271+06.48	RT	10	PR ROW
312+44.11	LT	10	EX ROW
TOTAL		20	

PAY ITEM NUMBER			X6026050	X6026051					
DESC.	STATION	OFFSET	SANITARY MANHOLE ADJ	SAN MAN RECONST	STRUCTURE TYPE	EX RIM ELEV	PROP RIM ELEV	PROP INVERT	COMMENTS
			EACH	EACH					
A7	998+86.36	31.89' RT	1		SANITARY	732.49	732.31	N/A	EX ROW
A8	997+77.16	58.97' LT	1		SANITARY	732.63	732.65	N/A	EX ROW
A9	1001+22.07	33.86' RT	1		SANITARY	732.99	733.32	N/A	EX ROW
A12	1010+77.44	47.96' RT	1		SANITARY	733.80	734.86	N/A	EX ROW
A13	1014+79.11	23.48' RT		1	SANITARY	735.16	736.65	N/A	EX ROW
A15	1018+93.78	21.09' RT		1	SANITARY	735.74	737.94	N/A	EX ROW
A16	1019+93.91	59.66' RT	1		SANITARY	735.82	735.73	N/A	EX ROW
A17	268+31.05	50.06' RT	1		SANITARY	735.27	735.70	N/A	EX ROW
A18	265+94.00	47.52' RT	1		SANITARY	735.61	736.19	N/A	EX ROW
A22	1024+60.56	61.03' RT		1	SANITARY	735.32	736.66	N/A	EX ROW
A23	866+17.94	109.07' RT	1		SANITARY	726.79	726.34	N/A	EX ROW
TOTAL			8	3					

PAY ITEM NUMBER		56400500	56500700	
LOCATION		FIRE HYDNTS TO BE REM	DOM WAT SER BOX REM	COMMENTS
STATION	OFFSET	EACH	EACH	
60+73.87	9.17' LT	1		EX ROW
269+40.94	102.32' LT	1		EX ROW
990+00.00	12.00' LT		1	EX ROW
990+00.00	17.00' LT		1	EX ROW
990+00.00	22.00' LT		1	EX ROW
TOTAL		2	3	

PAY ITEM NUMBER			60500070					
DESC.	STATION	OFFSET	REMOV MAN- MAIN FLOW	STRUCTURE TYPE	EX RIM ELEV	PROP RIM ELEV	PROP INVERT	COMMENTS
			EACH					
2400	1008+41.80	55.13' RT	1	SANITARY	727.27	N/A	N/A	SEE REMOVAL NOTE THIS SHEET/ EX ROW

PAYMENT NOTE:
 WATER MODIFICATIONS WITHIN THE EXISTING ROW WILL BE PAID FOR BY THE NORTH PARK PUBLIC WATER DISTRICT (NPPWD).
 SANITARY MODIFICATIONS WITHIN THE EXISTING ROW WILL BE PAID FOR BY THE ROCK RIVER WATER RECLAMATION DISTRICT (RRWRD).
 WATER AND SANITARY MODIFICATIONS WITHIN THE PROPOSED ROW WILL BE PAID FOR AS ROADWAY FEDERAL/STATE.

REMOVAL NOTE:
 MANHOLE 2400 IS TO BE COMPLETELY REMOVED AND FLOW IS TO BE MAINTAINED BY BYPASS PUMPING WHILE THIS OPERATION OCCURS, CONTRACTOR TO ASSUME A FLOW OF 1.6 MGD FOR BYPASS PUMPING. RECONNECT PIPES WITH 10' MINIMUM OF 21" PVC SDR 35 PIPE. CONNECTION TO THE EXISTING RCP PIPE REQUIRES 2 FERNCO COUPLINGS. THE NEW PIPE SHALL BE INSTALLED SO THAT THE FLOWLINES MATCH THE EXISTING RCP PIPE. THE CONTRACTOR WILL CONTACT TERRY STOLL, (815) 543-7983, AT LEAST 48 HOURS BEFORE BEGINNING THE WORK. THE BYPASS PUMPING, NEW PVC PIPE, COUPLINGS, AND ALL OTHER MATERIALS AND WORK NECESSARY TO COMPLETE MANHOLE REMOVAL SHALL NOT BE PAID SEPARATELY BUT WILL BE INCLUDED IN THE COST OF REMOVING MANHOLES TO MAINTAIN FLOW.

SCHEDULE OF QUANTITIES

LOCATION		PRE- STAGE 1		PRE- STAGE 2		PRE- STAGE 3		WINTER STAGE	
		70300210 TEMP PVT MK LTR & SYM	70301000 WORK ZONE PAVT MK REM	70300210 TEMP PVT MK LTR & SYM	70301000 WORK ZONE PAVT MK REM	70300210 TEMP PVT MK LTR & SYM	70301000 WORK ZONE PAVT MK REM	70300210 TEMP PVT MK LTR & SYM	70301000 WORK ZONE PAVT MK REM
		SQFT	SQFT	SQFT	SQFT	SQFT	SQFT	SQFT	SQFT
RALSTON ROAD/IL 173									
998+00	1013+50	276	-	276	276	213	276	94	213
1013+50	1028+00	254	-	343	254	312	343	16	312
SUBTOTALS		529	-	619	530	525	619	109	525

LOCATION		STAGE 1 A		STAGE 1 B		STAGE 1 C		STAGE 2 A		STAGE 2 B		STAGE 2 C		STAGE 3		STAGE 4 A		STAGE 4 B	
		70300210 TEMP PVT MK LTR & SYM	70301000 WORK ZONE PAVT MK REM	70300210 TEMP PVT MK LTR & SYM	70301000 WORK ZONE PAVT MK REM	70300210 TEMP PVT MK LTR & SYM	70301000 WORK ZONE PAVT MK REM	70300210 TEMP PVT MK LTR & SYM	70301000 WORK ZONE PAVT MK REM	70300210 TEMP PVT MK LTR & SYM	70301000 WORK ZONE PAVT MK REM	70300210 TEMP PVT MK LTR & SYM	70301000 WORK ZONE PAVT MK REM	70300210 TEMP PVT MK LTR & SYM	70301000 WORK ZONE PAVT MK REM	70300210 TEMP PVT MK LTR & SYM	70301000 WORK ZONE PAVT MK REM	70300210 TEMP PVT MK LTR & SYM	70301000 WORK ZONE PAVT MK REM
		SQFT	SQFT	SQFT	SQFT	SQFT	SQFT	SQFT	SQFT	SQFT	SQFT	SQFT	SQFT	SQFT	SQFT	SQFT	SQFT	SQFT	SQFT
RALSTON ROAD/IL 173																			
980+50	995+50		59											16		16	16	16	16
995+50	1010+50	78	50	31				94	31	62	31	47	16	203		140	203	156	156
1010+50	1025+50	156						16		62			125	203	125	172	203	62	62
1025+50	1040+50	109						218		78			140		187	109	31	187	
ROUTE 251																			
855+00	868+00	62		47	15			31		31		31	16	31	47	16			
868+00	875+00	47		62						31		62	47	31	16	62	31		
875+00	885+00												16						
ORLANDO ST																			
74+00	78+00												16			16			
78+00	80+00	16											31			16		47	47
N. 2ND FRONTAGE ROAD																			
310+00	313+00	47											16			16		16	16
313+00	320+00	31											47			31		31	31
ALPINE ROAD																			
259+00	266+00	47						47					16	16		31	78		
266+00	274+00	62						78					94	47		156	47		47
274+00	280+00	31					62	78					62			47			47
SUBTOTALS		686	109	140	15	62	-	562	31	265	31	702	78	702	312	827	703	328	422

70300210 TEMP PVT MK LTR & SYM TOTAL =	6,057 SQ FT
70301000 WORK ZONE PAVT MK REM SUB-TOTAL =	3,375 SQ FT

SCHEDULE OF QUANTITIES

LOCATION		PRE-STAGE 1		PRE-STAGE 2		PRE-STAGE 3		WINTER STAGE																				
		70300220 TEMP PVT MK LINE 4	70301000 WORK ZONE PAVT MK REM	70300220 TEMP PVT MK LINE 4	70301000 WORK ZONE PAVT MK REM	70300220 TEMP PVT MK LINE 4	70301000 WORK ZONE PAVT MK REM	70300220 TEMP PVT MK LINE 4	70301000 WORK ZONE PAVT MK REM																			
STATION TO STATION		FOOT	SQFT	FOOT	SQFT	FOOT	SQFT	FOOT	SQFT																			
STATION TO STATION		WHITE	YELLOW	WHITE	YELLOW	WHITE	YELLOW	WHITE	YELLOW																			
RALSTON ROAD/IL 173																												
998+00	1013+50	1,485	1,655	1,230	1,383	871	1,319	1,583	967	2,881	2,502	776																
1013+50	1028+00	766	751	823	485	436	745	847	531	2,611	2,638	436																
SUB-TOTAL		2,251	2,406	2,053	1,868	1,307	2,064	2,430	1,498	5,492	5,140	1,212																
LOCATION		STAGE 1 A		STAGE 1 B		STAGE 1 C		STAGE 2 A		STAGE 2 B		STAGE 2 C		STAGE 3		STAGE 4 A		STAGE 4 B										
		70300220 TEMP PVT MK LINE 4	70301000 WORK ZONE PAVT MK REM	70300220 TEMP PVT MK LINE 4	70301000 WORK ZONE PAVT MK REM	70300220 TEMP PVT MK LINE 4	70301000 WORK ZONE PAVT MK REM	70300220 TEMP PVT MK LINE 4	70301000 WORK ZONE PAVT MK REM	70300220 TEMP PVT MK LINE 4	70301000 WORK ZONE PAVT MK REM	70300220 TEMP PVT MK LINE 4	70301000 WORK ZONE PAVT MK REM	70300220 TEMP PVT MK LINE 4	70301000 WORK ZONE PAVT MK REM	70300220 TEMP PVT MK LINE 4	70301000 WORK ZONE PAVT MK REM	70300220 TEMP PVT MK LINE 4	70301000 WORK ZONE PAVT MK REM									
STATION TO STATION		FOOT	SQFT	FOOT	SQFT	FOOT	SQFT	FOOT	SQFT	FOOT	SQFT	FOOT	SQFT	FOOT	SQFT	FOOT	SQFT	FOOT	SQFT									
STATION TO STATION		WHITE	YELLOW	WHITE	YELLOW	WHITE	YELLOW	WHITE	YELLOW	WHITE	YELLOW	WHITE	YELLOW	WHITE	YELLOW	WHITE	YELLOW	WHITE	YELLOW									
RALSTON ROAD/IL 173																												
980+50	995+50	1,350	1,273					1,586	1,687	598	436	298	200	1,074	1,386	166	1,577	820	60	263								
995+50	1010+50	2,909	2,438	1,561	149	150		1,918	1,980	50	610	717		1,341	2,995	162	2,292	191	1,433	864	2,166	1,077						
1010+50	1025+50	2,464	2,080	1,546				2,238	2,201	207	261			1,067	3,862	1,111	692	2,404	822	713	904	1,032						
1025+50	1040+50	1,914	1,610					2,162	2,392	733				849	2,557		464	1,107	721									
ROUTE 251																												
855+00	868+00	2,951	3,104		3,227	3,038				182	122		2,836	3,104	101	1,231	1,602	493		140	2,528	2,326	944					
868+00	875+00	1,306	1,162		1,248	1,205							1,252	1,209	818	881	629	410	201	480	133	590	475	503				
875+00	885+00	2,644	2,263		2,628	2,187	936						2,658	2,263	1,605	1,033	876	817		128	1,918	1,466	636					
ORLANDO ST																												
74+00	78+00	422	613					536	991	115	9			74	603	3				186	362	218	32	427	172			
78+00	80+00	213	244					282	290				108	62			411	400	57		61	254	270		368	228		
N. 2ND FRONTAGE ROAD																												
310+00	313+00	957	478					478	476				195	395	478								202	301	958	336		
313+00	320+00	220	547					153	546				402	680	241									8	1,078	410		
ALPINE ROAD																												
259+00	266+00	351	628							507	1,304	120	151	196			923	532	683			1,199	473			400		
266+00	274+00	1,149	1,207							1,162	722						1,214	731	600	258	248	26	1,634	169			545	
274+00	280+00	407	1,660					24	151	345	712	2,031					374	1,660	457		128	56	1,439	43			480	
SUB-TOTAL		19,256	19,307	3,107	7,253	6,580	936	655	1,173	345	11,883	14,794	1,738	8,429	8,249	2,524	8,345	11,072	4,070	5,676	11,904	1,713	8,814	14,434	7,254	1,978	5,900	4,941

70300220 TEMP PVT MK LINE 4, TOTAL =	188,751	ADD 10% =	207,627	FOOT
70301000 WORK ZONE PAVT MK REM SUB-TOTAL =	30,644	SQ FT		

SCHEDULE OF QUANTITIES

LOCATION		PRE- STAGE 1		PRE- STAGE 2		PRE- STAGE 3		WINTER STAGE											
STATION TO STATION		70300250	70301000	70300250	70301000	70300250	70301000	70300250	70301000										
		TEMP PVT MK	WORK ZONE	TEMP PVT MK	WORK ZONE	TEMP PVT MK	WORK ZONE	TEMP PVT MK	WORK ZONE										
		LINE 8	PAVT MK	LINE 8	PAVT MK	LINE 8	PAVT MK	LINE 8	PAVT MK										
		FOOT	SQ FT	FOOT	SQ FT	FOOT	SQ FT	FOOT	SQ FT										
RALSTON ROAD/IL 173																			
998+00	1013+50	201			134	317		734	245										
1013+50	1028+00	25		115	38	114	38	370	123										
SUB-TOTAL		226		115	172	431	38	1,104	368										
LOCATION		STAGE 1 A		STAGE 1 B		STAGE 1 C		STAGE 2 A		STAGE 2 B		STAGE 2 C		STAGE 3		STAGE 4 A		STAGE 4 B	
STATION TO STATION		70300250	70301000	70300250	70301000	70300250	70301000	70300250	70301000	70300250	70301000	70300250	70301000	70300250	70301000	70300250	70301000	70300250	70301000
		TEMP PVT MK	WORK ZONE	TEMP PVT MK	WORK ZONE	TEMP PVT MK	WORK ZONE	TEMP PVT MK	WORK ZONE	TEMP PVT MK	WORK ZONE	TEMP PVT MK	WORK ZONE	TEMP PVT MK	WORK ZONE	TEMP PVT MK	WORK ZONE	TEMP PVT MK	WORK ZONE
		LINE 8	PAVT MK	LINE 8	PAVT MK	LINE 8	PAVT MK	LINE 8	PAVT MK	LINE 8	PAVT MK	LINE 8	PAVT MK	LINE 8	PAVT MK	LINE 8	PAVT MK	LINE 8	PAVT MK
		FOOT	SQ FT	FOOT	SQ FT	FOOT	SQ FT	FOOT	SQ FT	FOOT	SQ FT	FOOT	SQ FT	FOOT	SQ FT	FOOT	SQ FT	FOOT	SQ FT
RALSTON ROAD/IL 173																			
980+50	995+50													250		114	166		23
995+50	1010+50	761	490	74				798	167	58				1,385		496	453	591	740
1010+50	1025+50	786	246					868					100	1,335	67	460	553	313	420
1025+50	1040+50	432						1,030	160					1,209		150	480		
ROUTE 251																			
855+00	868+00							56					123						488
868+00	875+00	564		582	97					656	310		437	51		1,312	47		563
875+00	885+00										21			32			21		8
ORLANDO ST																			
74+00	78+00												61			29			45
78+00	80+00																	124	85
N. 2ND FRONTAGE ROAD																			
310+00	313+00																		300
313+00	320+00																		152
ALPINE ROAD																			
259+00	266+00	151						110	13				30			300	41		379
266+00	274+00	939						499					418	76		979	51		777
274+00	280+00	40				323	16	179					154			226	21		97
SUB-TOTAL		3,673	736	656	97	323	16	3,540	340	714	454	763	437	4,338	67	4,066	1,834	1,480	4,036

70300250 TEMP PVT MK LINE 8 TOTAL =	21,429	ADD 10% =	23,572	FOOT
70301000 WORK ZONE PAVT MK REM SUB-TOTAL =		8,596	SQ FT	

SCHEDULE OF QUANTITIES

LOCATION		PRE-STAGE 1		PRE-STAGE 2		PRE-STAGE 3		WINTER STAGE	
STATION TO STATION	70300280	70301000	70300280	70301000	70300280	70301000	70300280	70301000	
	TEMP PVT MK	WORK ZONE	TEMP PVT MK	WORK ZONE	TEMP PVT MK	WORK ZONE	TEMP PVT MK	WORK ZONE	
	LINE 24	PAVT MK	LINE 24	PAVT MK	LINE 24	PAVT MK	LINE 24	PAVT MK	
	FOOT	SQFT	FOOT	SQFT	FOOT	SQFT	FOOT	SQFT	
RALSTON ROAD/IL 173									
998+00	1013+50	45		36	90	48	72	84	168
1013+50	1028+00	21			72	40		12	24
SUB-TOTAL		66	-	36	162	88	72	96	192

LOCATION		STAGE 1 A		STAGE 1 B		STAGE 1 C		STAGE 2 A		STAGE 2 B		STAGE 2 C		STAGE 3		STAGE 4 A		STAGE 4 B	
STATION TO STATION	70300280	70301000	70300280	70301000	70300280	70301000	70300280	70301000	70300280	70301000	70300280	70301000	70300280	70301000	70300280	70301000	70300280	70301000	
	TEMP PVT MK	WORK ZONE	TEMP PVT MK	WORK ZONE	TEMP PVT MK	WORK ZONE	TEMP PVT MK	WORK ZONE	TEMP PVT MK	WORK ZONE	TEMP PVT MK	WORK ZONE	TEMP PVT MK	WORK ZONE	TEMP PVT MK	WORK ZONE	TEMP PVT MK	WORK ZONE	
	LINE 24	PAVT MK	LINE 24	PAVT MK	LINE 24	PAVT MK	LINE 24	PAVT MK	LINE 24	PAVT MK	LINE 24	PAVT MK	LINE 24	PAVT MK	LINE 24	PAVT MK	LINE 24	PAVT MK	
	FOOT	SQFT	FOOT	SQFT	FOOT	SQFT	FOOT	SQFT	FOOT	SQFT	FOOT	SQFT	FOOT	SQFT	FOOT	SQFT	FOOT	SQFT	
RALSTON ROAD/IL 173																			
980+50	995+50	18													117		73		
995+50	1010+50	139	168	60					118		128	236	58	24	107	23	280	48	
1010+50	1025+50	62							139		12		58	72	107		110	192	24
1025+50	1040+50	48							86				64	48	129			260	
ROUTE 251																			
855+00	868+00	57							84		57	336							
868+00	875+00	70		68	68				136	100			44	120	95		90	134	
875+00	885+00																		
ORLANDO ST																			
74+00	78+00												24	24					
78+00	80+00	12							12	24			14	24	12		32	24	42
N. 2ND FRONTAGE ROAD																			
310+00	313+00	12					12		12	24			32		12		32	24	44
313+00	320+00																		
ALPINE ROAD																			
259+00	266+00																58		
266+00	274+00	49						48	48	48			53	96	48	106	130	96	
274+00	280+00	27											59			118			
SUB-TOTAL		494	168	128	68	12	48	499	232	297	572	406	408	627	224	548	1,010	158	168

70300280 TEMP PVT MK LINE 24 TOTAL =	3,455	ADD 10% =	3,801	FOOT
70301000 WORK ZONE PAVT MK REM SUB-TOTAL =	3,324	SQ FT		

70301000 WORK ZONE PAVT MK REM SUB-TOTAL =	3,375	SQ FT
70301000 WORK ZONE PAVT MK REM SUB-TOTAL =	30,644	SQ FT
70301000 WORK ZONE PAVT MK REM SUB-TOTAL =	8,596	SQ FT
70301000 WORK ZONE PAVT MK REM SUB-TOTAL =	3,324	SQ FT
70301000 WORK ZONE PAVT MK REM TOTAL =	45,940	SQ FT

SCHEDULE OF QUANTITIES

LOCATION			PRE-STAGE 1		PRE-STAGE 2		PRE-STAGE 3	WINTER STAGE
STATION TO STATION	OFFSET	70400100	70400200	70400100	70400200	70400200	70400200	
		TEMP CONC BARRIER	REL TEMP CONC BARRIER	TEMP CONC BARRIER	REL TEMP CONC BARRIER	REL TEMP CONC BARRIER	REL TEMP CONC BARRIER	
		FOOT	FOOT	FOOT	FOOT	FOOT	FOOT	
RALSTON ROAD/IL 173								
1005+45.15	1010+41.82	RT	500.0					
1007+67.18	1011+29.69	LT	350.0					
1006+65.33	1011+80.97	LT			87.5	425.0		
1006+68.62	1010+92.99	RT				425.0		
1007+29.45	110+85.07	RT					362.5	
ROUTE 251								
858+80.00	861+58.73	LT						275.0
863+12.50	865+91.24	RT						275.0
880+20.00	882+23.69	LT						200.0
SUB-TOTAL			850.0	0.0	87.5	850.0	362.5	750.0

LOCATION			STAGE 1 A		STAGE 1 B	STAGE 1 C	STAGE 2 A	STAGE 2 B	STAGE 2 C
STATION TO STATION	OFFSET	70400100	70400200	70400200	70400200	70400200	70400200	70400200	70400200
		TEMP CONC BARRIER	REL TEMP CONC BARRIER	REL TEMP CONC	REL TEMP CONC	REL TEMP CONC BARRIER	REL TEMP CONC BARRIER	REL TEMP CONC BARRIER	REL TEMP CONC
		FOOT	FOOT	FOOT	FOOT	FOOT	FOOT	FOOT	FOOT
IL 173									
1018+14.58	1019+11.47	LT		150.0					
1019+56.51	1024+36.79	LT		662.5					
1019+51.80	1020+45.59	RT		112.5					
1018+00.14	119+77.52	RT				175.0			
1018+32.81	1019+61.41	RT					225.0		
1020+06.30	1024+61.99	RT					575.0		
IL ROUTE 251									
858+58.44	869+47.08	LT/RT	1075.0						
869+47.08	869+59.78			12.5					
858+58.44	870+10.46	LT/RT						1137.5	
863+16.10	865+83.95	RT			262.5				
858+73.80	861+52.31	RT			275.0				
860+26.54	869+75.29	RT			950.0				
866+19.27	867+82.40	LT							162.5
869+75.29	870+13.30	RT					37.5		
871+30.30	882+03.28	LT/RT	1062.5						
871+44.56	881+70.81	RT			1012.5				
871+93.65	882+03.28	LT/RT						1000.0	
SUB-TOTAL			2137.5	937.5	2500.0	175.0	837.5	2137.5	162.5

70400100 TEMPORARY CONCRETE BARRIER, TOTAL=	3075.0	FOOT
70400200 RELOCATE TEMPORARY CONCRETE BARRIER, TOTAL=	8712.5	FOOT

SCHEDULE OF QUANTITIES

LOCATION		PRE-STAGE 1		PRE-STAGE 2		PRE-STAGE 3		WINTER STAGE			STAGE 1A			STAGE 2B			STAGE 2A			STAGE 2B		STAGE 2C		STAGE 3
STATION	OFFSET	Z0030250 IMP	Z0030260 IMP	Z0030330 IMP	Z0030350 IMP	Z0030350 IMP	Z0030250 IMP	Z0030330 IMP	Z0030350 IMP	Z0030260 IMP	Z0030280 IMP	Z0030330 IMP	Z0030330 IMP	Z0030350 IMP	Z0030370 IMP	Z0030330 IMP	Z0030350 IMP	Z0030370 IMP	Z0030370 IMP	Z0030350 IMP	Z0030370 IMP	Z0030370 IMP		
		ATTN TEMP NRD TL3	ATTN TEMP FRN TL3	ATTN REL FRD TL3	ATTN REL NRD TL3	ATTN REL NRD TL3	ATTN TEMP NRD TL3	ATTN REL FRD TL3	ATTN REL NRD TL3	ATTN TEMP NRD TL3	ATTN TEMP FRN TL3	ATTN TEMP SUN TL3	ATTN REL FRD TL3	ATTN REL FRD TL3	ATTN REL NRD TL3	ATTN REL SUN TL3	ATTN REL FRD TL3	ATTN REL NRD TL3	ATTN REL SUN TL3	ATTN REL SUN TL3	ATTN REL NRD TL3	ATTN REL SUN TL3	ATTN REL SUN TL3	
		EACH	EACH	EACH	EACH	EACH	EACH	EACH	EACH	EACH	EACH	EACH	EACH	EACH	EACH	EACH	EACH	EACH	EACH	EACH	EACH	EACH		
RALSTON ROAD/IL 173																								
1005+45.15	RT	1																						
1011+29.69	LT		1																					
1011+80.97	LT				1																			
1006+68.62	RT			1																				
1007+29.45	RT					1																		
1019+11.47	LT												1											
1019+51.80	RT									1														
1018+32.81	RT														1									
1020+06.30	RT															1								
1024+36.79	LT									1														
IL ROUTE 251																								
858+58.44	RT										1									1				
858+73.80	RT														1									
858+80.00	LT							1																
863+12.50	RT								1															
863+16.10	RT												1							1				
866+19.27	LT																							
869+47.11	LT																					1		
869+59.78	LT										1													
869+75.29	RT															1								
869+97.79	LT																							
870+10.46	LT																			1				
870+13.30	RT																				1			
871+30.30	LT										1													
871+44.56	RT															1								
871+93.65	LT																				1			
872+20.58	RT																			1				
880+20.00	LT							1																
881+70.81	RT															1								
SUB-TOTAL		1	1	1	1	1	1	1	1	2	3	1	1	1	3	1	1	2	3	1	1	1		

Z0030250 IMPACT ATTENUATORS, TEMPORARY (NON- REDIRECTIVE), TEST LEVEL 3, TOTAL =	2	EACH
Z0030260 IMPACT ATTENUATORS, TEMPORARY (FULLY REDIRECTIVE, NARROW), TEST LEVEL 3, TOTAL =	3	EACH
Z0030280 IMPACT ATTENUATORS, TEMPORARY (SEVERE USE, NARROW), TEST LEVEL 3, TOTAL =	3	EACH
Z0030330 IMPACT ATTENUATORS, RELOCATE (FULLY REDIRECTIVE), TEST LEVEL 3, TOTAL =	5	EACH
Z0030350 IMPACT ATTENUATORS, RELOCATE (NON- REDIRECTIVE), TEST LEVEL 3, TOTAL =	6	EACH
Z0030370 IMPACT ATTENUATORS, RELOCATE (SEVERE USE, NARROW), TEST LEVEL 3, TOTAL =	10	EACH

SCHEDULE OF QUANTITIES

78008200 POLYUREA PAVEMENT MARKING TYPE I - LETTER AND SYMBOLS			
LOCATION (STATION)	OFFSET	SQ. FT.	DESCRIPTION
RALSTON ROAD			
991+49	4.32' RT	15.6	LT TURN ARROW
992+13	2.53' RT	15.6	LT TURN ARROW
992+76	1' RT	15.6	LT TURN ARROW
993+40	.5' RT	15.6	LT TURN ARROW
999+54	.2' RT	15.6	LT TURN ARROW
999+54	12' RT	15.6	LT TURN ARROW
995+65	.5' LT	15.6	LT TURN ARROW
996+23	.5' LT	15.6	LT TURN ARROW
996+85	2' LT	15.6	LT TURN ARROW
997+42	7' LT	15.6	LT TURN ARROW
999+04	44' RT	15.6	RT TURN ARROW
999+64	44' RT	15.6	RT TURN ARROW
1000+13	.2' RT	15.6	LT TURN ARROW
1000+13	12' RT	15.6	LT TURN ARROW
1000+24	44' RT	15.6	RT TURN ARROW
1000+73	.2' RT	15.6	LT TURN ARROW
1000+73	12' RT	15.6	LT TURN ARROW
1000+84	44' RT	15.6	RT TURN ARROW
1001+32	.2' RT	15.6	LT TURN ARROW
1001+32	12' RT	15.6	LT TURN ARROW
ILLINOIS ROUTE 173			
1004+01	.2' LT	15.6	LT TURN ARROW
1004+01	12' LT	15.6	LT TURN ARROW
1004+57	44' LT	15.6	RT TURN ARROW
1004+57	56' LT	15.6	RT TURN ARROW
1004+79	.2' LT	15.6	LT TURN ARROW
1004+79	12' LT	15.6	LT TURN ARROW
1005+17	44' LT	15.6	RT TURN ARROW
1005+17	56' LT	15.6	RT TURN ARROW
1005+58	.2' LT	15.6	LT TURN ARROW
1005+58	12' LT	15.6	LT TURN ARROW
1005+77	44' LT	15.6	RT TURN ARROW
1005+77	56' LT	15.6	RT TURN ARROW
1006+37	.2' LT	15.6	LT TURN ARROW
1006+37	12' LT	15.6	LT TURN ARROW
1006+37	44' LT	15.6	RT TURN ARROW
1006+37	56' LT	15.6	RT TURN ARROW
1009+22	44' RT	15.6	RT TURN ARROW
1009+73	.2' LT	15.6	LT TURN ARROW
1009+73	12' RT	15.6	LT TURN ARROW
1009+80	44' RT	15.6	RT TURN ARROW
1010+39	.2' LT	15.6	LT TURN ARROW
1010+39	12' RT	15.6	LT TURN ARROW
1010+39	44' RT	15.6	RT TURN ARROW
1010+97	44' RT	15.6	RT TURN ARROW
1011+05	.2' LT	15.6	LT TURN ARROW
1011+05	12' RT	15.6	LT TURN ARROW
1013+59	0	15.6	LT TURN ARROW
1013+96	44' LT	15.6	RT TURN ARROW

78008200 POLYUREA PAVEMENT MARKING TYPE I - LETTER AND SYMBOLS			
LOCATION (STATION)	OFFSET	SQ. FT.	DESCRIPTION
1014+31	0	15.6	LT TURN ARROW
1014+54	44' LT	15.6	RT TURN ARROW
1015+03	1' LT	15.6	LT TURN ARROW
1015+12	44' LT	15.6	RT TURN ARROW
1015+71	44' LT	15.6	RT TURN ARROW
1015+75	7' LT	15.6	LT TURN ARROW
1016+19	44' RT	15.6	RT TURN ARROW
1016+77	44' RT	15.6	RT TURN ARROW
1017+36	44' RT	15.6	RT TURN ARROW
1017+85	0	15.6	LT TURN ARROW
1017+85	12' RT	15.6	LT TURN ARROW
1017+94	44' RT	15.6	RT TURN ARROW
1018+57	12' RT	15.6	LT TURN ARROW
1018+57	44' RT	15.6	RT TURN ARROW
1020+84	0	15.6	LT TURN ARROW
1020+84	12' LT	15.6	LT TURN ARROW
1021+24	44' LT	15.6	RT TURN ARROW
1021+54	0	15.6	LT TURN ARROW
1021+54	12' LT	15.6	LT TURN ARROW
1021+83	44' LT	15.6	RT TURN ARROW
1022+26	0	15.6	LT TURN ARROW
1022+41	44' LT	15.6	RT TURN ARROW
1022+96	0	15.6	LT TURN ARROW
1022+99	44' LT	15.6	RT TURN ARROW
1025+95	4' RT	15.6	LT TURN ARROW
1026+70	4' RT	15.6	LT TURN ARROW
1027+44	4' RT	15.6	LT TURN ARROW
1029+45	2' LT	15.6	LT TURN ARROW
1029+85	22' LT	15.6	RT TURN ARROW
1030+15	2' LT	15.6	LT TURN ARROW
1030+44	22' LT	15.6	RT TURN ARROW
1030+85	2' LT	15.6	LT TURN ARROW
1031+02	22' LT	15.6	RT TURN ARROW
1031+56	2' LT	15.6	LT TURN ARROW
1031+61	22' LT	15.6	RT TURN ARROW
1034+17	24' RT	15.6	RT TURN ARROW
1034+24	3' RT	15.6	LT TURN ARROW
1034+75	24' RT	15.6	RT TURN ARROW
1034+99	3' RT	15.6	LT TURN ARROW
1035+33	24' RT	15.6	RT TURN ARROW
1035+72	3' RT	15.6	LT TURN ARROW
*78008200 POLYUREA PAVEMENT MARKING TYPE I - LETTER AND SYMBOLS			
LOCATION (STATION)	OFFSET	SQ. FT.	DESCRIPTION
ILLINOIS ROUTE 251			
866+66	9' RT	15.6	LT TURN ARROW
866+66	21' RT	15.6	LT TURN ARROW
866+66	53' RT	15.6	RT TURN ARROW
866+66	65' RT	15.6	RT TURN ARROW
867+36	9' RT	15.6	LT TURN ARROW
867+36	21' RT	15.6	LT TURN ARROW

78008200 POLYUREA PAVEMENT MARKING TYPE I - LETTER AND SYMBOLS			
LOCATION (STATION)	OFFSET	SQ. FT.	DESCRIPTION
867+36	53' RT	15.6	RT TURN ARROW
867+36	65' RT	15.6	RT TURN ARROW
868+06	9' RT	15.6	LT TURN ARROW
868+06	21' RT	15.6	LT TURN ARROW
868+06	53' RT	15.6	RT TURN ARROW
868+06	65' RT	15.6	RT TURN ARROW
868+76	9' RT	15.6	LT TURN ARROW
868+76	21' RT	15.6	LT TURN ARROW
868+76	53' RT	15.6	RT TURN ARROW
868+76	65' RT	15.6	RT TURN ARROW
869+46	9' RT	15.6	LT TURN ARROW
869+46	21' RT	15.6	LT TURN ARROW
869+46	53' RT	15.6	RT TURN ARROW
869+46	65' RT	15.6	RT TURN ARROW
872+06	9' LT	15.6	LT TURN ARROW
872+06	21' LT	15.6	LT TURN ARROW
872+06	53' LT	15.6	RT TURN ARROW
872+06	68' LT	15.6	RT TURN ARROW
872+76	9' LT	15.6	LT TURN ARROW
872+76	21' LT	15.6	LT TURN ARROW
872+76	53' LT	15.6	RT TURN ARROW
872+76	68' LT	15.6	RT TURN ARROW
873+46	9' LT	15.6	LT TURN ARROW
873+46	21' LT	15.6	LT TURN ARROW
873+46	53' LT	15.6	RT TURN ARROW
873+46	68' LT	15.6	RT TURN ARROW
874+16	9' LT	15.6	LT TURN ARROW
874+16	21' LT	15.6	LT TURN ARROW
874+16	53' LT	15.6	RT TURN ARROW
874+16	68' LT	15.6	RT TURN ARROW
874+86	9' LT	15.6	LT TURN ARROW
874+86	21' LT	15.6	LT TURN ARROW
874+86	53' LT	15.6	RT TURN ARROW
874+86	68' LT	15.6	RT TURN ARROW
ORLANDO ST			
78+22	4' RT	15.6	LT TURN ARROW
78+97	4' RT	15.6	LT TURN ARROW
N. 2ND FRONTAGE ROAD			
311+13	4' LT	15.6	LT TURN ARROW
311+13	13' LT	26	COMB. LT/THRU ARROW
311+20	32' LT	15.6	RT TURN ARROW
312+33	4' LT	15.6	LT TURN ARROW
312+33	12' LT	26	COMB. LT/THRU ARROW
312+33	24' LT	15.6	RT TURN ARROW
314+98	7' LT	15.6	LT TURN ARROW
315+79	18' RT	15.6	RT TURN ARROW
316+39	20' RT	15.6	RT TURN ARROW
ALPINE ROAD			
259+99	3' LT	15.6	LT TURN ARROW
261+64	0	15.6	LT TURN ARROW

78008200 POLYUREA PAVEMENT MARKING TYPE I - LETTER AND SYMBOLS			
LOCATION (STATION)	OFFSET	SQ. FT.	DESCRIPTION
263+19	3' LT	15.6	LT TURN ARROW
263+66	36' LT	15.6	RT TURN ARROW
263+84	3' LT	15.6	LT TURN ARROW
264+36	36' LT	15.6	RT TURN ARROW
264+56	3' LT	15.6	LT TURN ARROW
265+19	50' RT	15.6	RT TURN ARROW
265+79	50' RT	15.6	RT TURN ARROW
266+40	50' RT	15.6	RT TURN ARROW
267+00	6' RT	15.6	LT TURN ARROW
267+00	18' RT	15.6	LT TURN ARROW
267+06	50' RT	15.6	RT TURN ARROW
267+16	36' LT	15.6	RT TURN ARROW
267+62	6' RT	15.6	LT TURN ARROW
267+62	18' RT	15.6	LT TURN ARROW
267+66	50' RT	15.6	RT TURN ARROW
268+24	6' RT	15.6	LT TURN ARROW
268+24	18' RT	15.6	LT TURN ARROW
268+24	50' RT	15.6	RT TURN ARROW
268+86	6' RT	15.6	LT TURN ARROW
268+86	18' RT	15.6	LT TURN ARROW
268+86	50' RT	15.6	RT TURN ARROW
271+12	6' RT	15.6	LT TURN ARROW
271+12	6' LT	15.6	LT TURN ARROW
271+12	39' LT	15.6	RT TURN ARROW
271+81	39' LT	15.6	RT TURN ARROW
271+87	6' RT	15.6	LT TURN ARROW
271+87	6' LT	15.6	LT TURN ARROW
272+50	39' LT	15.6	RT TURN ARROW
273+78	41' RT	15.6	RT TURN ARROW
274+48	41' RT	15.6	RT TURN ARROW
275+34	65' RT	15.6	LT TURN ARROW
275+44	65' RT	15.6	RT TURN ARROW
275+86	18' LT	15.6	LT TURN ARROW
276+11	2' RT	15.6	LT TURN ARROW
276+41	19' LT	15.6	LT TURN ARROW
276+85	1' LT	15.6	LT TURN ARROW
276+96	20' LT	15.6	LT TURN ARROW
TOTAL		2813.2	

SCHEDULE OF QUANTITIES

78008210 POLYUREA PAVEMENT MARKING TYPE I - LINE 4"				
LOCATION				
STATION TO STATION	OFFSET	LF	DESCRIPTION	
RALSTON ROAD				
985+49	986+68	LT/RT	120.8	DOUBLE YELLOW
986+68	993+66	LT/RT	1403.2	MEDIAN
995+38	1001+66	LT/RT	1265.0	MEDIAN
IL ROUTE 173				
1003+68	1011+38	LT/RT	1548.4	MEDIAN
1013+27	1018+91	LT/RT	1140.5	MEDIAN
1020+60	1023+33	LT/RT	550.7	MEDIAN
1023+16	1025+76	LT/RT	1018.5	DOUBLE YELLOW MEDIAN
1025+76	1027+96	LT/RT	438.1	MEDIAN
1029+21	1036+24	LT/RT	1407.0	DOUBLE YELLOW MEDIAN
1029+40	1035+57	RT	618.0	SOLID EOP
1029+57	1035+80	LT	622.8	SOLID EOP
SMYTHE AVENUE				
41+15	42+30	RT	29.0	CL SKIP DASH LINE
BANYAN DRIVE				
10+09	12+11	RT	50.8	CL SKIP DASH LINE
12+11	12+50	LT/RT	39.0	DOUBLE YELLOW
N. 2ND STREET				
50+69	51+82		225.0	DOUBLE YELLOW
51+82	64+00		305.3	CL SKIP DASH LINE
IL ROUTE 251				
857+37	869+24	LT	1187.0	EOP SOLID WHITE
857+37	869+95	LT	1266.0	EOP SOLID YELLOW
857+37	869+95	RT	1256.6	EOP SOLID YELLOW
859+46	869+39	RT	994.3	EOP SOLID WHITE
871+54	884+18	RT	1273.5	EOP SOLID YELLOW
871+54	884.18	LT	1263.7	EOP SOLID YELLOW
872+16	884+18	LT	1203.3	EOP SOLID WHITE
872+35	884+18	RT	1184.6	EOP SOLID WHITE
ORLANDO ST				
74+99	79+25	LT/RT	1702.7	DOUBLE YELLOW MEDIAN
N. 2ND FRONTAGE ROAD				
310+85	313+76	LT/RT	596.2	DOUBLE YELLOW MEDIAN
314+69	316+76	LT/RT	372.6	DOUBLE YELLOW MEDIAN
ALPINE ROAD				
259+77	261+91	LT/RT	215.6	DOUBLE YELLOW MEDIAN
262+83	269+16	LT/RT	1277.6	SOLID MEDIAN LINE
270+80	RT (PARKING)		72.0	SOLID WHITE LINE
270+87	274+98	LT/RT	840.8	SOLID MEDIAN LINE
275+13		RT	38.0	DRIVEWAY
275+61	277+10	LT	160.2	DOUBLE YELLOW MEDIAN
277+69	279+49	LT/RT	373.1	DOUBLE YELLOW MEDIAN
TOTAL			26,060	

78008230 POLYUREA PAVEMENT MARKING TYPE I - LINE 6"				
LOCATION				
STATION TO STATION	OFFSET	LF	DESCRIPTION	
IL ROUTE 173				
1003+56	1011+36	LT	194.1	CL SKIP DASH LINE
1003+98	1011+88	RT	199.0	CL SKIP DASH LINE
1012+81	1019+01	LT/RT	293.9	CL SKIP DASH LINE
1020+75	1022+20	RT	36.3	CL SKIP DASH LINE
1020+46	1023+12	LT	63.4	CL SKIP DASH LINE
IL ROUTE 251				
857+37	869+24	LT	299.2	CL SKIP DASH LINE
857+37	870+06	RT	319.2	CL SKIP DASH LINE
871+42	884+18	LT	325.6	CL SKIP DASH LINE
872+11	884+18	RT	295.8	CL SKIP DASH LINE
N. 2ND FRONTAGE ROAD				
310+89	313+90	RT	72.5	CL SKIP DASH LINE
312+45	313+90	LT	34.6	CL SKIP DASH LINE
ALPINE ROAD				
259+77	261+99	LT/RT	111.6	CL SKIP DASH LINE
262+83	269+34	RT	162.6	CL SKIP DASH LINE
262+99	269+07	LT	152.1	CL SKIP DASH LINE
270+68	275+00	LT	108.0	CL SKIP DASH LINE
271+06	274+98	RT	98.2	CL SKIP DASH LINE
275+61	277+10	RT	40.0	CL SKIP DASH LINE
275+61	277+10	LT	40.0	CL SKIP DASH LINE
TOTAL			3,212	

78008240 POLYUREA PAVEMENT MARKING TYPE I - LINE 8"				
LOCATION				
STATION TO STATION	OFFSET	LF	DESCRIPTION	
RALSTON ROAD				
989+31	991+36	RT	52.0	SKIP DASH
991+36	993+65	RT	477.7	DIRECTIONAL
995+40	997+56	LT	450.1	DIRECTIONAL
996+30	999+42	RT	78.0	SKIP DASH
996+70	998+92	RT	56.0	SKIP DASH
997+56	999+42	LT	41.4	SKIP DASH
998+92	1001+72	RT	281.5	DIRECTIONAL
999+42	1001+77	RT	455.7	LT TURN DIRECTIONAL
1000+66	1001+85	LT	32.0	SKIP DASH
1001+42	1002+00	RT	163.6	ISLAND
1001+62	1003+30	LT	56.0	SKIP DASH
1001+64	1002+70	LT/RT	44.0	SKIP DASH
IL ROUTE 173				
1003+56	1006+49	LT	569.8	LT TURN DIRECTIONAL LANES
1003+89	1006+49	LT	526.2	RT TURN DIRECTIONAL LANES
1003+38	104+13	LT	127.3	ISLAND
106+49	1008+86	LT	60.0	SKIP DASH RT TURN LANE
1006+49	1009+61	LT	78.0	SKIP DASH LT TURN LANE
1006+49	1009+61	RT	79.7	SKIP DASH LT TURN LANE
1006+56	1009+10	RT	65.2	SKIP DASH RT TURN LANE
1009+10	1011+82	RT	277.6	RIGHT TURN LANE
1009+60	1011+36	RT	175.4	LT TURN DIRECTIONAL LANE
1009+60	1011+88	RT	228.9	LT TURN DIRECTIONAL LANE

78008240 POLYUREA PAVEMENT MARKING TYPE I - LINE 8"				
LOCATION				
STATION TO STATION	OFFSET	LF	DESCRIPTION	
1011+36	1012+43	LT	40.0	SKIP DASH
1011+59	1012+08	RT	77.7	ISLAND
1012+67	1013+29	LT	91.1	ISLAND
1012+81	1015+89	LT	626.5	ISLAND
1012+96	1015+83	LT	284.1	RT TURN DIRECTIONAL
1014+56	1017+73	RT	78.0	SKIP DASH LT TURN LANE
1015+23	1016+03	RT	46.0	SKIP DASH RT TURN LANE
1015+83	1017+73	LT	42.0	SKIP DASH RT TURN LANE
1015+87	1017+73	LT	47.9	SKIP DASH LT TURN LANE
1016+03	1019+01	RT	284.1	RT TURN DIRECTIONAL
1017+73	1019+01	RT	241.1	LT TURN DIRECTIONAL LANES
1018+54	1019+16	RT	101.1	ISLAND
1018+82	1019+68	RT	42.0	SKIP DASH LT TURN LANE (INTER)
1018+85	1019+96	LT	44.0	SKIP DASH LT TURN LANE (INTER)
1020+14	1020+62	LT	79.9	ISLAND
1020+32	1023+11	LT	280.0	RT TURN DIRECTIONAL LANE
1020+46	1022+20	LT	176.4	LT TURN DIRECTIONAL LANE
1020+46	1023+15	LT	254.3	LT TURN DIRECTIONAL LANE
1022+20	1025+35	LT	80.0	SKIP DASH LT TURN LANE
1023+11	1025+35	LT		SKIP DASH RT TURN LANE
1025+80	1027+87	RT	216.0	LT TURN DIRECTIONAL LANE
1029+21	1031+61	LT	253.1	LT TURN DIRECTIONAL LANE
1029+21	1032+33	LT	313.1	RT TURN DIRECTIONAL LANE
1031+61	1033+43	LT	44.0	SKIP DASH LT TURN LANE
1031+61	1033+43	RT	46.0	SKIP DASH RT TURN LANE
1031+61	1033+43	RT	46.6	SKIP DASH LT TURN LANE
1032+33	1035+06	LT	68.0	SKIP DASH RT TURN LANE
1033+43	1036+23	RT	278.8	LT TURN DIRECTIONAL LANE
1033+43	1035+89	RT	246.8	RT TURN DIRECTIONAL LANE
SMYTHE AVENUE				
40+26.65	41+14.55	RT	217.3	ISLAND
IL ROUTE 251				
857+43	858+70	RT	425.0	ISLAND
862+94	866+54	RT	90.0	SKIP DASH LT TURN LANE
862+94	866+54	RT	90.0	SKIP DASH RT TURN LANE
866+54	869+92	RT	338.5	LT TURN DIRECTIONAL LANE
866+54	870.06	RT	352.6	LT TURN DIRECTIONAL LANE
866+54	870+32	RT	378.0	RT TURN DIRECTIONAL LANE
866+54	870+03	RT	363.7	RT TURN DIRECTIONAL LANE
869+82	870+32	RT	90.8	ISLAND
869+34	870+99	LT/RT	58.0	SKIP DASH LT TURN LANE
870+03	870+90	RT	34.0	SKIP DASH RT TURN LANE
870+67	871+56	LT/RT	44.0	SKIP DASH LT TURN LANE
871+36	874+98	LT	356.8	RT TURN DIRECTIONAL LANE
871+22	871+77	LT	81.6	ISLAND
871+22	874+98	LT	376.4	RT TURN DIRECTIONAL LANE
871+42	874+98	LT	358.3	LT TURN DIRECTIONAL LANE
871+56	874+98	LT	348.0	LT TURN DIRECTIONAL LANE
871+56	874+98	LT	342.0	LT TURN DIRECTIONAL LANE

78008240 POLYUREA PAVEMENT MARKING TYPE I - LINE 8"				
LOCATION				
STATION TO STATION	OFFSET	LF	DESCRIPTION	
IL ROUTE 251				
874+98	878+58	LT	90.0	SKIP DASH LT TURN LANE
874+98	878+58	LT	90.0	SKIP DASH RT TURN LANE
ORLANDO ST				
78+06	79+25	RT	127.4	LT TURN DIRECTIONAL LANE
79+07	79+54	RT	117.1	ISLAND
N. 2ND FRONTAGE ROAD				
310+08	312+45	LT	173.5	LT TURN DIRECTIONAL LANE
310+58	312+45	LT	183.9	RT TURN DIRECTIONAL LANE
310+58	310+89	LT	53.6	ISLAND
314+61	315+52	RT	22.8	SKIP DASH RT TURN LANE
314+69	315+19	LT	50.0	LT TURN DIRECTIONAL LANE
315+19	315+94	LT	24.0	SKIP DASH LT TURN LANE
315+52	316+76	RT	121.5	RT TURN DIRECTIONAL LANE
ALPINE ROAD				
259+77	260+16	LT	39.8	LT TURN DIRECTIONAL LANE
260+16	260+96	LT	20.0	SKIP DASH LT TURN LANE
260+16	261+06	LT/RT	21.3	SKIP DASH LT TURN LANE
261+06	261+99	RT	188.4	ISLAND
262+99	264+51	LT	152.0	RT TURN DIRECTIONAL LANE
262+99	264+68	LT	171.7	LT TURN DIRECTIONAL LANE
263+75	266+87	RT	78.0	SKIP DASH LT TURN LANE
264+51	265+92	LT	46.0	SKIP DASH RT TURN LANE
264+68	266+68	LT	50.0	SKIP DASH LT TURN LANE
263+00	265+00	RT	46.0	SKIP DASH RT TURN LANE
266+28	267+31	LT	185.2	ISLAND
265+00	269+34	RT	434.0	RT TURN DIRECTIONAL LANE
266+87	269+13	RT	226.0	LT TURN DIRECTIONAL LANE
266+87	269+34	RT	246.1	LT TURN DIRECTIONAL LANE
267+31	268+51	LT	30.7	RT TURN DIRECTIONAL LANE
269+06	269+53	RT	77.5	ISLAND
269+06	270+06	LT/RT	46.0	SKIP DASH LT TURN LANE (INTER)
269+74	270+88	LT/RT	46.0	SKIP DASH LT TURN LANE (INTER)
270+47	270+93	LT	74.6	ISLAND
270+68	272+02	LT	134.0	LT TURN DIRECTIONAL LANE
270+64	272+65	LT	201.2	RT TURN DIRECTIONAL LANE
270+88	272+02	LT	114.0	LT TURN DIRECTIONAL LANE
272+65	274+53	LT	47.0	SKIP DASH RT TURN LANE
272+61	273+63	RT	34.5	SKIP DASH RT TURN LANE
272+65	274+11	LT	38.0	SKIP DASH RT TURN LANE
273+63	275+13	RT	150.1	RT TURN DIRECTIONAL LANE
274+73	275+13	RT	92.4	ISLAND
275+37		RT	38.0	DRIVEWAY
275+61	277+10	LT	149.2	LT TURN DIRECTIONAL LANE
275+96	277+10	RT	114.3	LT TURN DIRECTIONAL LANE
TOTAL			17,495	

SCHEDULE OF QUANTITIES

78008250 POLYUREA PAVEMENT MARKING TYPE I - LINE 12"				
LOCATION				
STATION TO STATION	OFFSET	LF	DESCRIPTION	
RALSTON ROAD				
991+36	993+65	RT	104.6	DIAGONALS DIRECTIONAL
995+40	997+56	LT	107.4	DIAGONALS DIRECTIONAL
1001+42	1002+00	RT	163.6	ISLAND DIAGONALS
IL ROUTE 173				
1003+38	104+13	LT	62.2	ISLAND DIAGONALS
1011+59	1012+08	RT	50.7	ISLAND DIAGONALS
1012+81	1015+89	LT	626.5	ISLAND DIAGONALS
1012+81	1015+89	LT	86.9	ISLAND DIAGONALS
1018+54	1019+16	RT	103	ISLAND DIAGONALS
1020+14	1020+62	LT	81.9	ISLAND DIAGONALS
SMYTHE AVENUE				
40+26.65	41+14.55	RT	164.2	ISLAND DIAGONALS
IL ROUTE 251				
857+37	858+70	RT	286.6	ISLAND DIAGONALS
869+82	870+32	RT	65.0	ISLAND DIAGONALS
871+22	871+77	LT	70.7	ISLAND DIAGONALS
ORLANDO ST				
79+07	79+54	RT	85.3	ISLAND DIAGONALS
N. 2ND FRONTAGE ROAD				
310+58	310+89	LT	5.2	ISLAND DIAGONALS
ALPINE ROAD				
261+06	261+99	RT	42	ISLAND DIAGONALS
266+28	267+31	LT	142.2	ISLAND DIAGONALS
269+06	269+53	RT	72.8	ISLAND DIAGONALS
274+73	275+13	RT	159.5	ISLAND DIAGONALS
270+47	270+93	LT	70.7	ISLAND DIAGONALS
TOTAL			2,551	

78008270 POLYUREA PAVEMENT MARKING TYPE I - LINE 24"				
LOCATION				
STATION TO STATION	OFFSET	LF	DESCRIPTION	
SMYTHE AVENUE				
991+36		RT	18	STOP BAR
RALSTON ROAD				
993+65		RT	24	STOP BAR
993+65		LT	12	STOP BAR
995+40		LT	24	STOP BAR THRU LANES
995+40		LT	12	STOP BAR LF TURN LANE
1001+62		RT	24	STOP BAR LF TURN LANE
1001+77		RT	24	STOP BAR THRU LANES
1001+65		RT	18	STOP BAR RIGHT LANE
IL ROUTE 173				
1003+56		LT	24	STOP BAR THRU LANES
1003+71		LT	24	STOP BAR LT TURN LANES
1003+73		LT	40	STOP BAR RT TURN LANES
1011+36		RT	24	STOP BAR LT TURN LANES
1011+80		RT	18	STOP BAR RIGHT TURN LANE

78008270 POLYUREA PAVEMENT MARKING TYPE I - LINE 24"				
LOCATION				
STATION TO STATION	OFFSET	LF	DESCRIPTION	
1011+88		RT	27	STOP BAR THRU LANES
1012+80		LT	24	STOP BAR THRU LANES
1013+99		LT	18	STOP BAR RT TURN LANES
1013+27		RT	12	STOP BAR LT TURN LANES
1018+78		RT	13	STOP BAR RT TURN LANES
1018+85		RT	24	STOP BAR LT TURN LANES
1019+01		RT	24	STOP BAR THRU LANES
1020+42		LT	18	STOP BAR RT TURN LANES
1020+46		LT	24	STOP BAR THRU LANES
1020+61		LT	24	STOP BAR LT TURN LANES
1027+87		RT	16	STOP BAR RIGHT TURN LANE
1027+87		RT	36	STOP BAR THRU LANES
1029+21		LT	27	STOP BAR
1029+21		LT	12	STOP BAR
1+29+29		LT	15	STOP BAR RIGHT TURN LANE
BANYAN DRIVE				
12+50		RT	74	STOP BAR
N. 2ND STREET				
50+69		LT	28	STOP BAR
51+82		LT	20	STOP BAR
IL ROUTE 251				
869+92		RT	28	STOP BAR LT TURN LANES
870+06		RT	24	STOP BAR THRU LANES
870+03		RT	35	STOP BAR RT TURN LANES
871+19		LT	36	STOP BAR RT TURN LANES
871+42		LT	24	STOP BAR THRU LANES
871+56		LT	28	STOP BAR LT TURN LANES
ORLANDO ST				
79+25		RT	12	STOP BAR LT TURN LANE
79+34		RT	12	STOP BAR THRU LANE
79+35		RT	18	STOP BAR RT TURN LANE
N. 2ND FRONTAGE ROAD				
310+58		LT	34	STOP BAR RT TURN LANE
310+08		LT	12	STOP BAR THRU LANE
310+85		LT	12	STOP BAR LT TURN LANE
ALPINE ROAD				
261+91		LT/RT	16	STOP BAR LT TURN LANE
261+99		RT	30	STOP BAR THRU LANE
262+42		RT	15	STOP BAR DRIVEWAY
262+99		LT	36	STOP BAR THRU LANE AND LT
269+25		RT	18	STOP BAR RT TURN LANE
269+34		RT	24	STOP BAR THRU LANE
269+13		LT	24	STOP BAR LT TURN LANE
270+68		LT	24	STOP BAR THRU LANE
270+73		LT	18	STOP BAR RT TURN LANE
270+88		LT	24	STOP BAR LT TURN LANE
275+25		RT	24	STOP BAR DRIVEWAY
275+49		RT	20	STOP BAR DRIVEWAY RT LANE
TOTAL			1,269	

78100100 RAISED REFLECTIVE PAVEMENT MARKING				
LOCATION				
STATION TO STATION	OFFSET	LF	DESCRIPTION	
RALSTON ROAD				
991+36	993+65	RT	12	THRU LANE
991+36	993+65	RT	12	LF LANE
992+34	993+65	RT	4	CL SKIP DASH LINE
992+94	996+65	LT	2	CL SKIP DASH LINE
995+40	1001+77	RT	16	CL SKIP DASH LINE
998+92	1001+77	RT	13	RIGHT TURN LANE
999+42	1001+77	RT	25	LEFT TURN LANES
995+40	997+56.21	LT	11	LEFT TURN LANE
995+40	997+56.21	LT	11	THRU LANE
995+40	101+77	LT	16	CL SKIP DASH LINE
IL ROUTE 173				
1003+89	1006+49	LT	28	RT TURN LANES
1003+98	1011+88	RT	20	CL SKIP DASH LINE
1009+10	1011+82	RT	14	RIGHT TURN LANE
1003+56	1011+33	LT	18	CL SKIP DASH LINE
1003+56	1006+49	LT	31	LT TURN DIRECTIONAL LANES
1009+60	1011+88	RT	21	LT TURN LANES
1012+81	1018+83	LT	16	CL SKIP DASH LINE
1013+27	1019+01	RT	14	CL SKIP DASH LINE
1012+81	1015+89	LT	32	ISLAND
1012+96	1015+83	LT	15	RT TURN DIRECTIONAL
1016+03	1019+01	RT	15	RT TURN DIRECTIONAL
1017+73	1019+01	RT	13	LT TURN DIRECTIONAL LANES
1020+75	1022+20	RT	4	CL SKIP DASH LINE
1020+46	1023+12	LT	7	CL SKIP DASH LINE
1020+32	1023+11	LT	14	RT TURN DIRECTIONAL LANE
1020+46	1022+20	LT	9	LT TURN DIRECTIONAL LANE
1020+46	1023+15	LT	13	LT TURN DIRECTIONAL LANE
IL ROUTE 251				
857+37	869+24	LT	30	CL SKIP DASH LINE
857+37	870+06	RT	32	CL SKIP DASH LINE
866+54	869+92	RT	17	LT TURN DIRECTIONAL LANE
866+54	870.06	RT	18	LT TURN DIRECTIONAL LANE
866+54	870+32	RT	18	RT TURN DIRECTIONAL LANE
866+54	870+03	RT	19	RT TURN DIRECTIONAL LANE
871+52	884+18	LT	32	CL SKIP DASH LINE
872+11	884+18	RT	30	CL SKIP DASH LINE
871+36	874+98	LT	18	RT TURN DIRECTIONAL LANE
871+22	874+98	LT	18	RT TURN DIRECTIONAL LANE
871+42	874+98	LT	18	LT TURN DIRECTIONAL LANE
871+56	874+98	LT	18	LT TURN DIRECTIONAL LANE

78100100 RAISED REFLECTIVE PAVEMENT MARKING				
LOCATION				
STATION TO STATION	OFFSET	LF	DESCRIPTION	
ALPINE ROAD				
264+30	269+33.59	RT	12	CL SKIP DASH LINE
265+00.00	269+33.59	RT	22	RT TURN DIRECTIONAL LANE
266+87.43	269+13.39	RT	12	LT TURN DIRECTIONAL LANE
266+87.43	269+33.59	RT	13	LT TURN DIRECTIONAL LANE
267+00.00	269+06.72	LT	6	CL SKIP DASH LINE
267+00.00	267+30.69	LT	2	RT TURN DIRECTIONAL LANE
270+64	272+65	LT	10	RT TURN DIRECTIONAL LANE
270+68	275+00	LT	12	CL SKIP DASH LINE
270+68	272+02	LT	7	LT TURN DIRECTIONAL LANE
270+88	272+02	LT	7	LT TURN DIRECTIONAL LANE
271+06	274+98	RT	10	CL SKIP DASH LINE
273+63	275+13	RT	6	RT TURN DIRECTIONAL LANE
TOTAL			793	

Z0005300 BOX CULVERTS TO BE CLEANED		
LOCATION		EACH
ROUTE 251		
863+89.59	LT/RT	1
TOTAL		1

Z0007601 BUILDING REMOVAL NO. 1			
LOCATION	STATION	OFFSET (FT)	LSUM
RALSTON RD			
BUILDING REMOVAL NO. 1	995+17	135 RT	1
TOTAL			1

Z0007602 BUILDING REMOVAL NO. 2			
LOCATION	STATION	OFFSET (FT)	LSUM
RALSTON RD			
BUILDING REMOVAL NO. 2	995+30	160 RT	1
TOTAL			1

Z0007603 BUILDING REMOVAL NO. 3			
LOCATION	STATION	OFFSET (FT)	LSUM
RALSTON RD			
BUILDING REMOVAL NO. 3	993+10	106 LT	1
TOTAL			1

SCHEDULE OF QUANTITIES

Z0062456 TEMPORARY PAVEMENT					
LOCATION		PRE-STAGE 1	PRE-STAGE 2	PRE-STAGE 3	COMMENTS
STATION TO STATION	OFFSET	SQ YD	SQ YD	SQ YD	
RALSTON ROAD/IL 173					
1006+73.82	1011+64.20	LT	1063		
1011+75.28	1012+02.70	LT	41		ISLAND
1012+53.29	1012+69.78	LT	25		ISLAND
1012+94.35	1016+58.88	LT	454		
1006+65.06	1010+92.99	RT		768	
1012+48.31	1012+85.43	RT		88	ISLAND
1013+35.73	1014+96.31	RT		77	
1008+35.06	1011+38.56	LT		918	
985+50.59	990+49.25	RT		536	SEE NOTE 1
991+12.62	993+14.01	RT		111	SEE NOTE 1
994+41.35	997+69.35	LT/RT		409	SEE NOTE 1
998+61.94	1002+01.70	LT/RT		150	SEE NOTE 1
999+22.47	1001+68.82	RT		236	SEE NOTE 1
1003+22.57	1011+09.17	RT		1600	SEE NOTE 1
1013+22.98	1018+44.44	RT		297	SEE NOTE 1
1020+49.54	1027+64.98	RT		848	SEE NOTE 1
1029+02.72	1032+96.73	RT		579	SEE NOTE 1
IL ROUTE 251					
857+79.16	858+04.84	RT		63	SEE NOTE 1
857+86.62	870+28.15	LT/RT		3701	SEE NOTE 1
861+90.00	870+23.67	RT		542	SEE NOTE 1
864+84.40	869+86.17	LT		351	SEE NOTE 1
871+25.57	883+30.03	LT/RT		1799	SEE NOTE 1
871+57.17	881+22.69	LT		626	SEE NOTE 1
ORLANDO STREET					
77+02.72	78+86.94	LT		156	SEE NOTE 1
N. ND FRONTAGE ROAD					
310+80.40	311+39.30	LT/RT		403	
311+15.68	313+68.91	LT		629	SEE NOTE 1
ALPINE ROAD					
262+87.51	269+40.90	LT/RT		459	SEE NOTE 1
267+69.06	269+30.83	LT		158	SEE NOTE 2
270+66.66	275+02.59	LT/RT		509	SEE NOTE 1
275+60.51	277+11.71	LT		38	SEE NOTE 1
SUB-TOTAL			1,583	933	15,118

NOTE 1: CONSTRUCTED AT THE END OF PRE-STAGE 3 (SHOWN AT WINTER STAGE)

LOCATION		STAGE 1A	STAGE 1B	STAGE 1C	STAGE 2A	STAGE 2B	STAGE 2C	COMMENTS
STATION TO STATION	OFFSET	SQ YD	SQ YD	SQ YD	SQ YD	SQ YD	SQ YD	
IL 173								
1001+83.88	1002+09.09	RT	57					ISLAND
1011+77.08	1012+02.70	LT	39					ISLAND
1011+85.95	1011+97.40	RT	13					ISLAND
1019+00.07	1019+24.25	RT	43					ISLAND
1019+04.15	1019+25.68	LT	34					ISLAND
1019+92.90	1020+13.42	RT	31					ISLAND
1003+46.64	1003+88.86	LT		88				ISLAND
1011+18.11	1012+94.76	LT/RT			942			
1011+57.13	1012+04.01	LT			110			
985+23.57	992+08.86	LT				1,082		
988+93.66	993+67.79	LT/RT				526		
997+85.86	1001+65.42	LT/RT				335		
1001+86.18	1002+14.82	LT				51		ISLAND
1007+90.78	1010+17.08	LT				141		
1008+05.40	1011+37.78	LT/RT				287		
1011+88.44	1013+28.19	RT				610		
1012+68.18	1012+95.92	RT				52		ISLAND
1016+72.57	1018+25.95	LT				60		
1019+07.15	1019+25.94	LT				24		ISLAND
1013+28.19	1018+90.62	LT/RT				489		
1019+38.07	1020+58.81	RT				552		
1020+13.82	1020+31.87	LT				28		ISLAND
1023+40.20	1028+01.26	LT				1,047		
1027+55.00	1028+00.00	LT				83		
1029+15.10	1035+79.05	LT				764		
1011+82.36	1012+04.06	RT					41	ISLAND
1003+16.51	1003+35.39	LT						32
ROUTE 251								
864+59.91	865+49.91	RT		109				
871+64.95	878+58.13	RT		972				
872+99.79	880+44.87	RT		241				
862+93.96	869+85.45	LT					1,188	
865+88.02	867+06.62	LT					67	
877+29.98	878+58.13	LT					60	
876+60.63	881+58.13	LT					127	
ORLANDO STREET								
75+90.84	78.86.82	RT				197		
N. 2ND FRONTAGE ROAD								
314+50.45	315+16.73					42		
ALPINE ROAD								
270+86.85	274+97.23	LT/RT			554			
264+87.43	266+86.11	LT/RT				75		
266+89.24	269+15.70	LT					150	
SUB-TOTAL			217	1,410	1,606	6,445	1,633	32

Z0062456 TEMP PAVEMENT TOTAL = 28,977 SQ YD

TEMPORARY PAVEMENT TO REMAIN			
LOCATION		OFFSET	SQ YD
STATION TO STATION	OFFSET		
1029+40.38	1032+95.87	RT	274
1029+66.02	1035+79.52	LT	388
TOTAL			662

X4400110 TEMP PAVT REMOVAL = 28,315 SQ YD

Z0014700 CULVERT TO BE CLEANED			
LOCATION		OFFSET	EACH
STATION	STATION		
IL 173			
1027+06.47	1029+81.66	RT	1
1027+45.53	1029+75.52	LT	1
1035+34.73	1037+85.50	LT	1
TOTAL			3

Z0022800 FENCE REMOVAL			
STATION	STATION	OFFSET	LENGTH (FT)
RALSTON RD			
989+69.58	989+86.59	LT	46
40+38.23	40+38.41	RT	29
12+08.99	12+08.99	RT	78
11+21.25	11+32.41	RT	63
1017+76.19	1017+74.56	RT	36
TOTAL			252

Z0026407 TEMPORARY SHEET PILING			
LOCATION		OFFSET	SQ FT
STATION	STATION		
IL 173 (PRE-STAGE 2)			
1008+87.54	1009+05.54	LT	234
1009+05.54	1009+47.54	LT	1092
1009+47.54	1009+62.54	LT	195
TOTAL			1521

Z0077700 WOOD FENCE TO BE REMOVED AND RE-ERECTED				
STATION	OFFSET	STATION	OFFSET	LENGTH (FT)
RALSTON RD				
989+69.58	70	LT	986+90.32	52.36
TOTAL				292

XZ127900 RETAINING WALL REMOVAL			
STATION	STATION	OFFSET	LENGTH (FT)
ILLINOIS ROUTE 173			
1012+68.28	1018+48.03	LT	597
1018+30.45	1018+66.89	LT	100
1012+69.64	1019+04.70	LT	753
TOTAL			1,450

X4402805 ISLAND REMOVAL			
STATION	STATION	OFFSET	AREA (SQ FT)
RALSTON RD			
1001+83.16	1002+09.09	RT	415
ILLINOIS ROUTE 173			
1003+33.78	1003+63.48	LT	455
1011+75.28	1012+02.70	LT	366
1012+53.29	1012+69.78	LT	224
1019+04.15	1019+25.68	LT	318
1019+92.53	1020+08.14	LT	215
1011+84.82	1011+97.40	RT	121
1012+52.54	1012+85.43	RT	793
1018+98.57	1019+24.25	RT	391
1019+92.87	1020+14.68	RT	280
ILLINOIS ROUTE 251			
857+79.16	858+04.82	RT	590
ALPINE RD			
274+98.15	275+13.47	RT	165
TOTAL			4,333

X4404000 PARKING LOT PAVEMENT REMOVAL			
STATION	STATION	OFFSET	AREA (SQ YD)
RALSTON RD			
986+92.07	988+06.44	LT	89
991+18.29	994+70.46	LT	1,762
995+19.96	996+58.12	RT	443
N. 2ND STREET			
58+22.28	59+42.77	LT	162
N. 2ND FRONTAGE RD			
311+84.19	313+68.76	RT	136
ALPINE RD			
270+90.91	271+33.39	RT	62
TOTAL			2,654

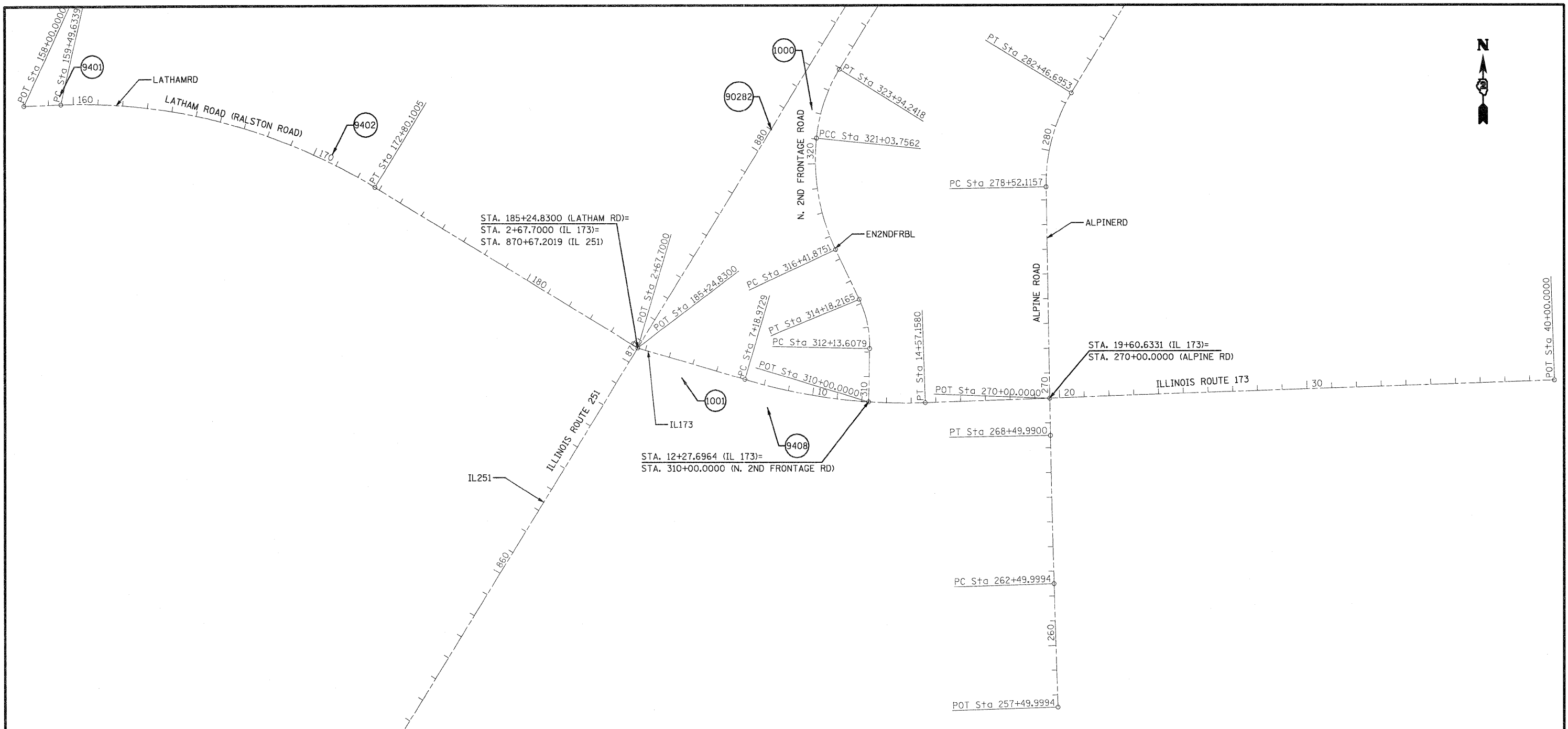

HORIZONTAL CONTROL POINTS

POINT	NORTH	EAST	ELEVATION	CHAIN	STATION	OFFSET	DESCRIPTION
9401	2078996.8160	2599987.6900	743.6110	LATHAMRD	159+46.2446	34.0202' LT	GPS CONTROL POINT
9402	2078762.3220	2601089.4020	737.8980	LATHAMRD	170+67.3045	34.3486' LT	GPS CONTROL POINT
1001	2077857.0866	2602500.2469	732.2954	IL173	4+72.9059	66.7435' RT	GPS CONTROL POINT
9408	2077739.5040	2602846.1720	732.5880	IL173	8+33.7998	84.4538' RT	GPS CONTROL POINT
1000	2078939.0960	2603027.7720	736.7070	IL251	882+54.1680	100.1179' RT	PROPERTY CORNER, GPS CONTROL POINT
90282	2078859.2030	2602863.5950	735.8090	IL251	881+00.2808	1.8544' RT	PHOTO CONTROL H. & V.

BENCH MARKS

POINT	NORTH	EAST	ELEVATION	CHAIN	STATION	OFFSET	DESCRIPTION
402	2078610.5560	2601207.4880	737.2260	LATHAMRD	172+43.6637	43.2423' RT	R.O.W. MARKER, SIGN FOUNDATION
404	2077760.4040	2602969.5170	731.9950	IL173	9+46.9498	37.9719' RT	FLARED END SECTION, HEADWALL
406	2077792.3160	2605768.6860	751.1480	IL173	37+41.4059	43.8710' RT	HEADWALL, R.O.W. MARKER

FILE NAME =
D264987-sh1-hvo-01.dgn

USER NAME = 3202090971
PLOT SCALE = 400.0000' / IN.
PLOT DATE = 1/18/2011

DESIGNED - LOM
DRAWN - MD
CHECKED - PDK
DATE - 01-19-2011

REVISED -
REVISED -
REVISED -
REVISED -

**STATE OF ILLINOIS
DEPARTMENT OF TRANSPORTATION**

EXISTING HORIZONTAL AND VERTICAL CONTROL

SCALE: SHEET NO. OF SHEETS STA. TO STA.

F.A.P. RTE.	SECTION	COUNTY	TOTAL SHEETS	SHEET NO.
303	129K-1	WINNEBAGO	401	50
FED. ROAD DIST. NO. 2 ILLINOIS FED. AID PROJECT				

CONTRACT NO. 64987

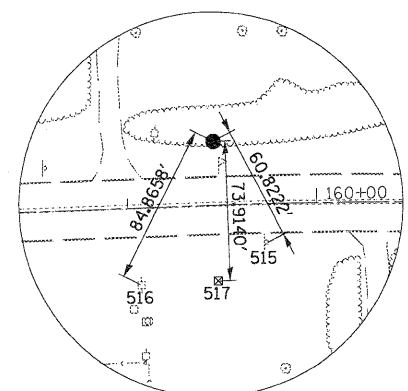

HORIZONTAL CONTROL POINT NO. 9401

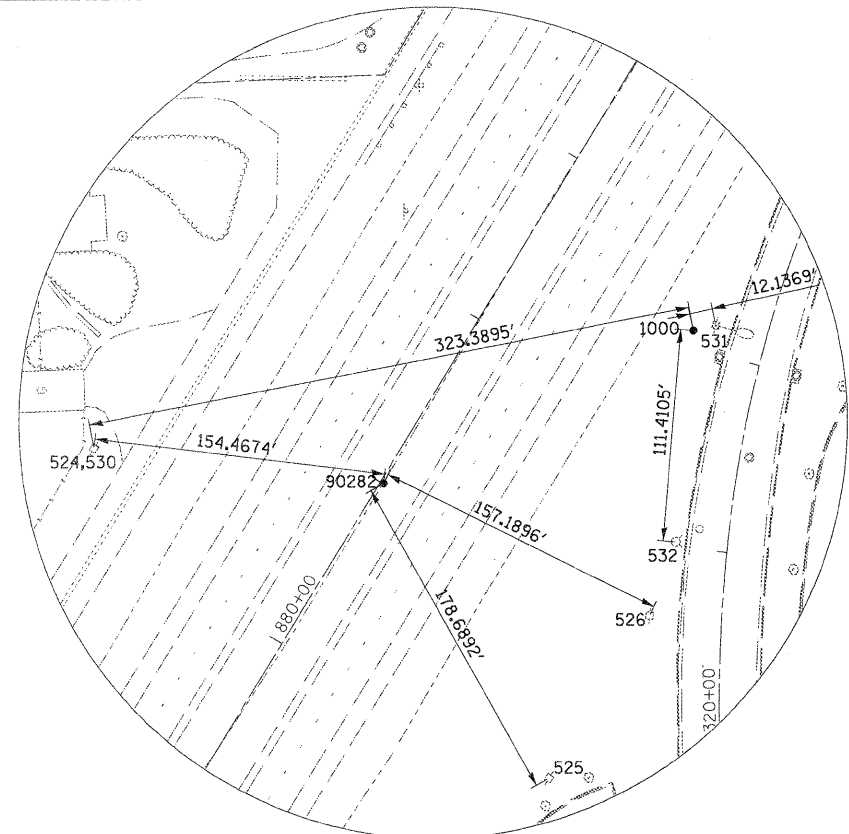

HORIZONTAL CONTROL POINT NO. 90282, 1000

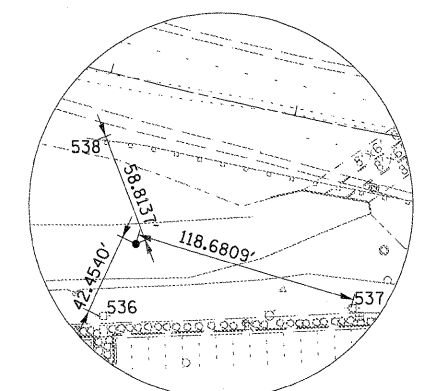

HORIZONTAL CONTROL POINT NO. 9408

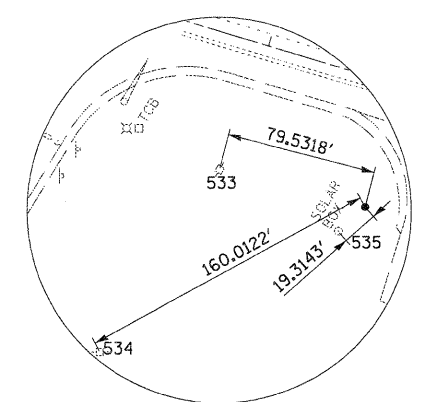

HORIZONTAL CONTROL POINT NO. 1001

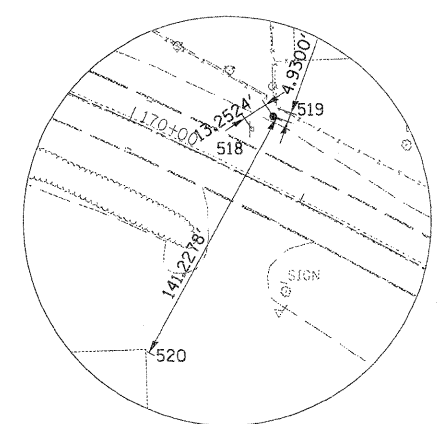

HORIZONTAL CONTROL POINT NO. 9402

REFERENCE TIES

POINT	CHAIN	STATION	OFFSET	DESCRIPTION
515	LATHAMRD	134+33.2992	31.2202' RT	POWER POLE, SIGN POLE
516	LATHAMRD	159+05.7778	40.5765' RT	SIGN POLE, POWER POLE
517	LATHAMRD	159+46.5304	39.8934' RT	POWER POLE, R.O.W. MARKER
518	LATHAMRD	170+60.3897	23.1993' LT	R.O.W. MARKER, SIGN POLE
519	LATHAMRD	170+66.7898	39.2508' LT	SIGN POLE, FENCE CORNER
520	LATHAMRD	170+60.8205	106.7354' RT	FENCE CORNER, COMMERCIAL BUILDING
524	IL251	880+35.9846	138.5958' LT	GUARDRAIL STEEL PLATE BEAM, POWER POLE
525	IL251	880+13.0720	157.8178' RT	POWER POLE
526	IL251	881+13.9667	158.4474' RT	POWER POLE
530	IL251	880+35.9986	138.5938' LT	POWER POLE
531	IL251	882+62.5985	108.8490' RT	POWER POLE, STREET LIGHT POLE
532	IL251	881+54.5184	149.9405' RT	STREET LIGHT POLE, FIRE HYDRANT
533	IL173	3+93.4253	69.4792' RT	FIRE HYDRANT, POWER POLE WITH TRANSFORMER
534	IL173	3+59.8795	180.0048' RT	POWER POLE WITH TRANSFORMER
535	IL173	4+62.8963	83.2606' RT	POWER POLE, TRAFFIC SIGNAL CONTROLLER
536	IL173	8+26.0240	126.1218' RT	TRAFFIC CONTROLLER, POWERPOLE W/TRANSFORMER
537	IL173	9+47.6756	94.0985' RT	POWER POLE WITH TRANSFORMER
538	IL173	8+00.9842	36.2353' RT	POWER POLE, GUARDPOST

SURVEY WORK POINTS

POINT	NORTH	EAST	ELEVATION	CHAIN	STATION	OFFSET	DESCRIPTION
1070	2078635.0090	2601290.7510	737.1510	LATHAMRD	173+02.6090	20.7941' LT	PI, GPS CONTROL POINT
1071	2078904.4600	2600450.8720	741.0340	LATHAMRD	164+14.7676	27.5009' RT	GPS CONTROL POINT
1083	2078216.0830	2602083.3880	730.7390	LATHAMRD	181+97.3629	77.2545' LT	TOPO SURVEY POINT, GPS CONTROL POINT
1073	2077894.2670	2603231.7830	733.4700	IL173	11+93.9950	130.0488' LT	GPS CONTROL POINT, TOPO SURVEY POINT
1074	2077816.3520	2604088.5900	735.6830	IL173	20+63.0977	37.2588' LT	TOPO SURVEY POINT, GPS CONTROL POINT
1075	2077779.8950	2604908.1900	737.3500	IL173	28+80.9849	27.0359' RT	GPS CONTROL POINT
1076	2077909.2360	2605928.7140	751.9080	IL173	39+05.3156	67.5419' LT	GPS CONTROL POINT
1079	2077901.2850	2603881.2040	733.8530	IL173	18+58.7185	129.1920' LT	GPS CONTROL POINT

FILE NAME =
D264987-shr-hvc-02.dgn

USER NAME = 3292090971
PLOT SCALE = 400.0000' / IN.
PLOT DATE = 1/18/2011

DESIGNED - LOM
DRAWN - MD
CHECKED - PDK
DATE - 01-19-2011

REVISED -
REVISED -
REVISED -
REVISED -

STATE OF ILLINOIS
DEPARTMENT OF TRANSPORTATION

EXISTING HORIZONTAL AND VERTICAL CONTROL

F.A.P. RTE.	SECTION	COUNTY	TOTAL SHEETS	SHEET NO.
303	129K-1	WINNEBAGO	401	51
CONTRACT NO. 64987				

SCALE: SHEET NO. OF SHEETS STA. TO STA.

FED. ROAD DIST. NO. 2 ILLINOIS FED. AID PROJECT

EXISTING LATHAM ROAD (RALSTON ROAD)
Chain LATHAMRD contains:
60005 CUR 240 250
Beginning chain LATHAMRD description

Point 60005 N 2,078,957.7837 E 2,599,842.7026 Sta 158+00.0000
Course from 60005 to PC 240 88° 01' 40.9943" Dist 149.6339'

Curve Data

Curve 240
P.I. Station 166+34.4168 N 2,078,986.4961 E 2,600,676.6253
Delta = 33° 26' 24.1747" (RT)
Degree = 2° 30' 48.2674"
Tangent = 684.7829'
Length = 1,330.4666'
Radius = 2,279.6056'
External = 100.6317'
Long Chord = 1,311.6634'
Mid. Ord. = 96.3771'
P.C. Station 159+49.6339 N 2,078,962.9326 E 2,599,992.2479
P.T. Station 172+80.1005 N 2,078,629.0231 E 2,601,260.6978
C.C. N 2,076,684.6770 E 2,600,070.6895

Course from PT 240 to 250 121° 28' 05.1690" Dist 1,244.7295'

Point 250 N 2,077,979.2446 E 2,602,322.3661 Sta 185+24.8300

Ending chain LATHAMRD description

LATHAMRD CURVE POINT NUMBERS					
CHAIN	CURVE	PI	CC	PC	PT
LATHAMRD	240	240	241	242	243

EXISTING ILLINOIS ROUTE 173
Chain IL173 contains:
1250 CUR 260 60010
Beginning chain IL173 description

Point 1250 N 2,077,979.2446 E 2,602,322.3661 Sta 2+67.7000

Course from 1250 to PC 260 106° 27' 42.4748" Dist 451.2729'

Curve Data

Curve 260
P.I. Station 10+91.2740 N 2,077,745.8635 E 2,603,112.1809
Delta = 18° 24' 34.9257" (LT)
Degree = 2° 29' 38.0916"
Tangent = 372.3011'
Length = 738.1850'
Radius = 2,297.4237'
External = 29.9705'
Long Chord = 735.0137'
Mid. Ord. = 29.5846'
P.C. Station 7+18.9729 N 2,077,851.3647 E 2,602,755.1409
P.T. Station 14+57.1580 N 2,077,758.5183 E 2,603,484.2668
C.C. N 2,080,054.6145 E 2,603,406.1756

Course from PT 260 to 60010 88° 03' 07.5491" Dist 2,542.8420'

Point 60010 N 2,077,844.9515 E 2,606,025.6395 Sta 40+00.0000

Ending chain IL173 description

IL173 CURVE POINT NUMBERS					
CHAIN	CURVE	PI	CC	PC	PT
IL173	260	260	261	262	263

EXISTING ILLINOIS ROUTE 251
Chain IL251 contains:
174 175
Beginning chain IL251 description

Point 174 N 2,073,992.7940 E 2,599,880.3040 Sta 823+92.2200

Course from 174 to 175 31° 29' 28.4748" Dist 8,594.2418'

Point 175 N 2,081,321.2760 E 2,604,369.6630 Sta 909+86.4618

Ending chain IL251 description

EXISTING ALPINE ROAD
Chain ALPNERD contains:
1047 CUR 300 310 CUR 380 167
Beginning chain ALPNERD description

Point 1047 N 2,076,526.0622 E 2,604,019.5874 Sta 257+49.9994

Course from 1047 to PC 300 358° 14' 38.8291" Dist 500.0000'

Curve Data

Curve 300
P.I. Station 265+49.9994 N 2,077,325.6866 E 2,603,995.0745
Delta = 0° 47' 06.7200" (RT)
Degree = 0° 07' 51.1274"
Tangent = 300.0000'
Length = 599.9906'
Radius = 43,781.1127'
External = 1.0278'
Long Chord = 599.9859'
Mid. Ord. = 1.0278'
P.C. Station 262+49.9994 N 2,077,025.8274 E 2,604,004.2668
P.T. Station 268+49.9900 N 2,077,625.6435 E 2,603,989.9923
C.C. N 2,078,367.3291 E 2,647,764.8221

Course from PT 300 to 310 359° 01' 45.5491" Dist 150.0100'

Point 310 N 2,077,775.6320 E 2,603,987.4510 Sta 270+00.0000

Course from 310 to PC 380 359° 01' 45.5491" Dist 852.1157'

Curve Data

Curve 380
P.I. Station 280+54.8509 N 2,078,830.3315 E 2,603,969.5810
Delta = 32° 26' 28.8232" (RT)
Degree = 8° 13' 18.2914"
Tangent = 202.7352'
Length = 394.5796'
Radius = 696.8808'
External = 28.8908'
Long Chord = 389.3299'
Mid. Ord. = 27.7408'
P.C. Station 278+52.1157 N 2,078,627.6254 E 2,603,973.0155
P.T. Station 282+46.6953 N 2,079,003.2460 E 2,604,075.4214
C.C. N 2,078,639.4311 E 2,604,669.7963

Course from PT 380 to 167 31° 28' 14.3723" Dist 1,297.3973'

Point 167 N 2,080,109.8060 E 2,604,752.7430 Sta 295+44.0926

Ending chain ALPNERD description

ALPNERD CURVE POINT NUMBERS					
CHAIN	CURVE	PI	CC	PC	PT
ALPNERD	300	300	301	302	303
ALPNERD	380	380	381	382	383

EXISTING N. 2ND FRONTAGE ROAD
Chain EN2NDFRBL contains:
72340 CUR 72350 CUR 72360 CUR 72370 70036
Beginning chain EN2NDFRBL description

Point 72340 N 2,077,762.1746 E 2,603,254.9298 Sta 310+00.0000

Course from 72340 to PC 72350 1° 14' 46.6931" Dist 213.6079'

Curve Data

Curve 72350
P.I. Station 313+17.7713 N 2,078,079.8708 E 2,603,261.8415
Delta = 26° 28' 06.9593" (LT)
Degree = 12° 56' 10.3656"
Tangent = 104.1634'
Length = 204.6086'
Radius = 442.9100'
External = 12.0837'
Long Chord = 202.7940'
Mid. Ord. = 11.7628'
P.C. Station 312+13.6079 N 2,077,975.7320 E 2,603,259.5759
P.T. Station 314+18.2165 N 2,078,174.1033 E 2,603,217.4542
C.C. N 2,077,985.3655 E 2,602,816.7706

Course from PT 72350 to PC 72360 334° 46' 39.7338" Dist 223.6586'

Curve Data

Curve 72360
P.I. Station 318+78.6711 N 2,078,590.6588 E 2,603,021.2400
Delta = 31° 08' 02.1357" (RT)
Degree = 6° 44' 26.4478"
Tangent = 236.7960'
Length = 461.8811'
Radius = 850.0000'
External = 32.3675'
Long Chord = 456.2195'
Mid. Ord. = 31.1802'
P.C. Station 316+41.8751 N 2,078,376.4386 E 2,603,122.1462
P.T. Station 321+03.7562 N 2,078,826.1955 E 2,603,045.6287
C.C. N 2,078,738.6502 E 2,603,891.1083

Curve Data

Curve 72370
P.I. Station 322+51.4656 N 2,078,973.1194 E 2,603,060.8419
Delta = 25° 36' 19.9306" (RT)
Degree = 8° 48' 53.0471"
Tangent = 147.7094'
Length = 290.4856'
Radius = 650.0000'
External = 16.5719'
Long Chord = 288.0743'
Mid. Ord. = 16.1599'
P.C. Station 321+03.7562 N 2,078,826.1955 E 2,603,045.6287
P.T. Station 323+94.2418 N 2,079,099.0392 E 2,603,138.0576
C.C. N 2,078,759.2491 E 2,603,692.1720

Course from PT 72370 to 70036 31° 31' 01.8001" Dist 3,009.9556'

Point 70036 N 2,081,664.9770 E 2,604,711.5240 Sta 354+04.1974

Ending chain EN2NDFRBL description

EN2NDFRBL CURVE POINT NUMBERS					
CHAIN	CURVE	PI	CC	PC	PT
EN2NDFRBL	72350	72350	72351	72352	72353
EN2NDFRBL	72360	72360	72361	72362	72363
EN2NDFRBL	72370	72370	72371	72372	72373

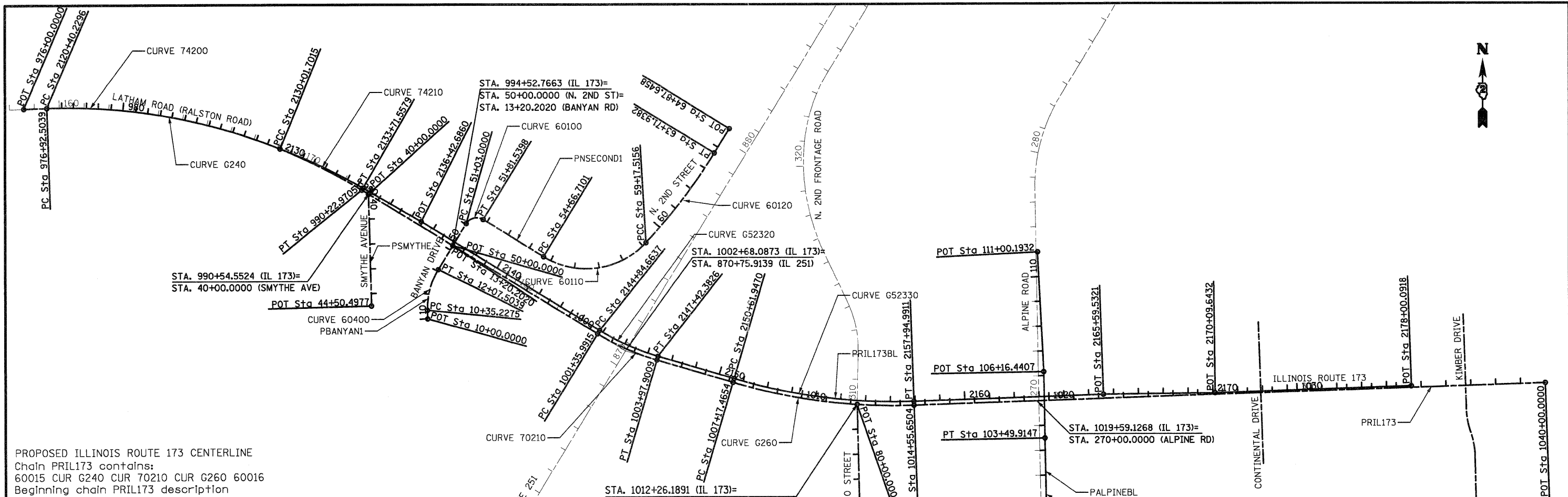

PROPOSED ILLINOIS ROUTE 173 CENTERLINE
 Chain PRIL173 contains:
 60015 CUR G240 CUR 70210 CUR G260 60016
 Beginning chain PRIL173 description

Point 60015 N 2,078,959.7495 E 2,599,899.7988 Sta 976+00.0000

Course from 60015 to PC G240 88° 01' 40.9942" Dist 92.5039'

Curve Data

Curve G240
 P.I. Station 983+77.2868 N 2,078,986.4961 E 2,600,676.6253
 Delta = 33° 26' 24.1747" (RT)
 Degree = 2° 30' 48.2674"
 Tangent = 684.7829'
 Length = 1,330.4666'
 Radius = 2,279.6056'
 External = 100.6317'
 Long Chord = 1,311.6634'
 Mid. Ord. = 96.3771'
 P.C. Station 976+92.5039 N 2,078,962.9326 E 2,599,992.2479
 P.T. Station 990+22.9705 N 2,078,629.0231 E 2,601,260.6978
 C.C. N 2,076,684.6770 E 2,600,070.6895

Course from PT G240 to PC 70210 121° 28' 05.1690" Dist 1,113.0210'

Curve Data

Curve 70210
 P.I. Station 1002+67.7000 N 2,077,979.2446 E 2,602,322.3661
 Delta = 15° 00' 22.6942" (LT)
 Degree = 5° 43' 46.4806"
 Tangent = 131.7085'
 Length = 261.9094'
 Radius = 1,000.0000'
 External = 8.6363'
 Long Chord = 261.1615'
 Mid. Ord. = 8.5623'
 P.C. Station 1001+35.9915 N 2,078,047.9996 E 2,602,210.0279
 P.T. Station 1003+97.9009 N 2,077,941.9216 E 2,602,448.6757
 C.C. N 2,078,900.9305 E 2,602,732.0517

Course from PT 70210 to PC G260 106° 27' 42.4748" Dist 319.5645'

Curve Data

Curve G260
 P.I. Station 1010+89.7665 N 2,077,745.8635 E 2,603,112.1809
 Delta = 18° 24' 34.9257" (LT)
 Degree = 2° 29' 38.0916"
 Tangent = 372.3011'
 Length = 738.1850'
 Radius = 2,297.4237'
 External = 29.9705'
 Long Chord = 735.0137'
 Mid. Ord. = 29.5846'
 P.C. Station 1007+17.4654 N 2,077,851.3647 E 2,602,755.1409
 P.T. Station 1014+55.6504 N 2,077,758.5183 E 2,603,484.2668
 C.C. N 2,080,054.6145 E 2,603,406.1756

Course from PT G260 to 60016 88° 03' 07.5491" Dist 2,544.3496'

Point 60016 N 2,077,845.0027 E 2,606,027.1461 Sta 1040+00.0000

Ending chain PRIL173 description

PRIL173 CURVE POINT NUMBERS

CHAIN	CURVE	PI	CC	PC	PT
PRIL173	G240	240	241	242	243
PRIL173	70210	70210	70211	70212	70213
PRIL173	G260	260	261	262	263

Curve Data

Curve 74200
 P.I. Station 2125+28.2212 N 2,078,979.7244 E 2,600,479.9505
 Delta = 24° 09' 56.5511" (RT)
 Degree = 2° 30' 48.2672"
 Tangent = 487.9916'
 Length = 961.4719'
 Radius = 2,279.6056'
 External = 51.6467'
 Long Chord = 954.3612'
 Mid. Ord. = 50.5026'
 P.C. Station 2120+40.2296 N 2,078,962.9326 E 2,599,992.2479
 P.T. Station 2130+01.7015 N 2,078,795.3905 E 2,600,931.7876
 C.C. N 2,076,684.6770 E 2,600,070.6894

Course from PT 74200 to PC 74210 292° 08' 08.6740" Dist 0.0000'

Curve Data

Curve 74210
 P.I. Station 2131+87.0352 N 2,078,729.6865 E 2,601,105.0838
 Delta = 9° 16' 56.2320" (RT)
 Degree = 2° 30' 34.9229"
 Tangent = 185.3337'
 Length = 369.8563'
 Radius = 2,282.9725'
 External = 7.5104'
 Long Chord = 369.4520'
 Mid. Ord. = 7.4858'
 P.C. Station 2130+01.7016 N 2,078,795.3905 E 2,600,931.7876
 P.T. Station 2133+71.5579 N 2,078,636.8905 E 2,601,265.5128
 C.C. N 2,076,660.6981 E 2,600,122.4349

PROPOSED ILLINOIS ROUTE 173 BASELINE CONTINUED
 Course from PT 74210 to 71011 120° 02' 09.6228" Dist 271.1281'

Point 71011 N 2,078,501.1789 E 2,601,500.2314 Sta 2136+42.6860

Course from 71011 to PC G52320 121° 28' 05.1690" Dist 841.9777'

Curve Data

Curve G52320
 P.I. Station 2146+14.2648 N 2,077,993.9916 E 2,602,328.9211
 Delta = 15° 00' 22.6942" (LT)
 Degree = 5° 49' 21.8706"
 Tangent = 129.6011'
 Length = 257.7189'
 Radius = 984.0000'
 External = 8.4981'
 Long Chord = 256.9829'
 Mid. Ord. = 8.4253'
 P.C. Station 2144+84.6637 N 2,078,061.6465 E 2,602,218.3803
 P.T. Station 2147+42.3826 N 2,077,957.2658 E 2,602,453.2097
 C.C. N 2,078,900.9305 E 2,602,732.0517

Course from PT G52320 to PC G52330 106° 27' 42.4748" Dist 319.5645'

Curve Data

Curve G52330
 P.I. Station 2154+31.6553 N 2,077,761.9424 E 2,603,114.2284
 Delta = 18° 24' 34.9257" (LT)
 Degree = 2° 30' 41.0564"
 Tangent = 369.7082'
 Length = 733.0440'
 Radius = 2,281.4237'
 External = 29.7618'
 Long Chord = 729.8948'
 Mid. Ord. = 29.3785'
 P.C. Station 2150+61.9470 N 2,077,866.7089 E 2,602,759.6749
 P.T. Station 2157+94.9911 N 2,077,774.5091 E 2,603,483.7230
 C.C. N 2,080,054.6145 E 2,603,406.1756

Course from PT G52330 to 71012 88° 03' 07.5491" Dist 764.5410'

Point 71012 N 2,077,800.4964 E 2,604,247.8222 Sta 2165+59.5321

Course from 71012 to 71013 89° 19' 30.4572" Dist 450.1111'

Point 71013 N 2,077,805.7981 E 2,604,697.9021 Sta 2170+09.6432

Course from 71013 to 71014 88° 03' 07.5491" Dist 790.4486'

Point 71014 N 2,077,832.6660 E 2,605,487.8939 Sta 2178+00.0918

Ending chain PRIL173BL description

PRIL173BL CURVE POINT NUMBERS					
CHAIN	CURVE	PI	CC	PC	PT
PRIL173BL	74200	74200	74201	74202	74203
PRIL173BL	74210	74210	74211	74212	74213
PRIL173BL	G52320	52320	52321	52322	52323
PRIL173BL	G52330	52330	52331	52332	52333

PROPOSED SMYTHE AVENUE
 Chain PSMYTHE contains:
 50390 50391
 Beginning chain PSMYTHE description

Point 50390 N 2,078,612.5365 E 2,601,287.6350 Sta 40+00.0000

Course from 50390 to 50391 178° 33' 56.6506" Dist 450.4977'

Point 50391 N 2,078,162.1800 E 2,601,298.9110 Sta 44+50.4977

Ending chain PSMYTHE description

PROPOSED N. 2ND STREET
 Chain PNSECOND1 contains:
 60100 CUR 60100 CUR 60110 CUR 60120 D50251
 Beginning chain PNSECOND1 description

Point 60100 N 2,078,404.6594 E 2,601,627.2840 Sta 50+00.0000

Course from 60100 to PC 60100 31° 28' 05.1690" Dist 103.0000'

Curve Data

Curve 60100
 P.I. Station 51+53.0000 N 2,078,535.1578 E 2,601,707.1536
 Delta = 90° 00' 00.0004" (RT)
 Degree = 114° 35' 29.6125"
 Tangent = 50.0000'
 Length = 78.5398'
 Radius = 50.0000'
 External = 20.7107'
 Long Chord = 70.7107'
 Mid. Ord. = 14.6447'
 P.C. Station 51+03.0000 N 2,078,492.5113 E 2,601,681.0524
 P.T. Station 51+81.5398 N 2,078,509.0566 E 2,601,749.8002
 C.C. N 2,078,466.4101 E 2,601,723.6990

Course from PT 60100 to PC 60110 121° 28' 05.1690" Dist 285.1702'

Curve Data

Curve 60110
 P.I. Station 57+35.2309 N 2,078,220.0167 E 2,602,222.0604
 Delta = 78° 16' 13.6782" (LT)
 Degree = 17° 21' 44.4867"
 Tangent = 268.5208'
 Length = 450.8055'
 Radius = 330.0000'
 External = 95.4450'
 Long Chord = 416.5609'
 Mid. Ord. = 74.0327'
 P.C. Station 54+66.7101 N 2,078,360.1910 E 2,601,993.0307
 P.T. Station 59+17.5156 N 2,078,415.7676 E 2,602,405.8675
 C.C. N 2,078,641.6582 E 2,602,165.2986

Curve Data

Curve 60120
 P.I. Station 61+45.5080 N 2,078,581.9733 E 2,602,561.9322
 Delta = 11° 36' 47.0473" (LT)
 Degree = 2° 33' 20.0360"
 Tangent = 227.9924'
 Length = 454.4227'
 Radius = 2,242.0000'
 External = 11.5626'
 Long Chord = 453.6452'
 Mid. Ord. = 11.5033'
 P.C. Station 59+17.5156 N 2,078,415.7676 E 2,602,405.8675
 P.T. Station 63+71.9382 N 2,078,776.1927 E 2,602,681.3447
 C.C. N 2,079,950.4548 E 2,600,771.4565

Course from PT 60120 to D50251 31° 35' 04.4435" Dist 115.7075'

Point D50251 N 2,078,874.7603 E 2,602,741.9472 Sta 64+87.6458

Ending chain PNSECOND1 description

PNSECOND1 CURVE POINT NUMBERS					
CHAIN	CURVE	PI	CC	PC	PT
PNSECOND1	60100	60100	60101	60102	60103
PNSECOND1	60110	60110	60111	60112	60113
PNSECOND1	60120	60120	60121	60122	60123

PROPOSED BANYAN DRIVE
 Chain PBANYAN1 contains:
 60400 CUR 60400 60404
 Beginning chain PBANYAN1 description

Point 60400 N 2,078,109.2031 E 2,601,525.3079 Sta 10+00.0000

Course from 60400 to PC 60400 358° 33' 56.6506" Dist 35.2275'

Curve Data

Curve 60400
 P.I. Station 11+23.8136 N 2,078,232.9780 E 2,601,522.2089
 Delta = 32° 54' 08.5184" (RT)
 Degree = 19° 05' 54.9354"
 Tangent = 88.5861'
 Length = 172.2764'
 Radius = 300.0000'
 External = 12.8058'
 Long Chord = 169.9190'
 Mid. Ord. = 12.2816'
 P.C. Station 10+35.2275 N 2,078,144.4196 E 2,601,524.4262
 P.T. Station 12+07.5039 N 2,078,308.5358 E 2,601,568.4529
 C.C. N 2,078,151.9286 E 2,601,824.3322

Course from PT 60400 to 60404 31° 28' 05.1690" Dist 112.6980'

Point 60404 N 2,078,404.6594 E 2,601,627.2840 Sta 13+20.2020

Ending chain PBANYAN1 description

PBANYAN1 CURVE POINT NUMBERS					
CHAIN	CURVE	PI	CC	PC	PT
PBANYAN1	60400	60400	60401	60402	60403

PROPOSED ORLANDO STREET
 Chain PORLAND01 contains:
 73011 73200
 Beginning chain PORLAND01 description

Point 73011 N 2,077,100.2980 E 2,603,270.7300 Sta 73+37.9344

Course from 73011 to 73200 358° 37' 57.0836" Dist 662.0656'

Point 73200 N 2,077,762.1750 E 2,603,254.9300 Sta 80+00.0000

Ending chain PORLAND01 description

PROPOSED ALPINE ROAD BASELINE
 Chain PALPINEBL contains:
 CUR 60500 60504 60505
 Beginning chain PALPINEBL description

Curve Data

Curve 60500
 P.I. Station 101+25.0347 N 2,077,401.1646 E 2,604,015.7988
 Delta = 0° 35' 20.0261" (RT)
 Degree = 0° 07' 51.3642"
 Tangent = 224.8839'
 Length = 449.7639'
 Radius = 43,759.1127'
 External = 0.5779'
 Long Chord = 449.7619'
 Mid. Ord. = 0.5778'
 P.C. Station 99+00.1508 N 2,077,176.3640 E 2,604,021.9194
 P.T. Station 103+49.9147 N 2,077,626.0162 E 2,604,011.9891
 C.C. N 2,078,367.3291 E 2,647,764.8222

Course from PT 60500 to 60504 359° 01' 45.5491" Dist 266.5260'

Point 60504 N 2,077,892.5039 E 2,604,007.4740 Sta 106+16.4407

Course from 60504 to 60505 357° 07' 12.6003" Dist 483.7526'

Point 60505 N 2,078,375.6456 E 2,603,983.1696 Sta 111+00.1932

Ending chain PALPINEBL description

PALPINEBL CURVE POINT NUMBERS					
CHAIN	CURVE	PI	CC	PC	PT
PALPINEBL	60500	60500	60501	60502	60503

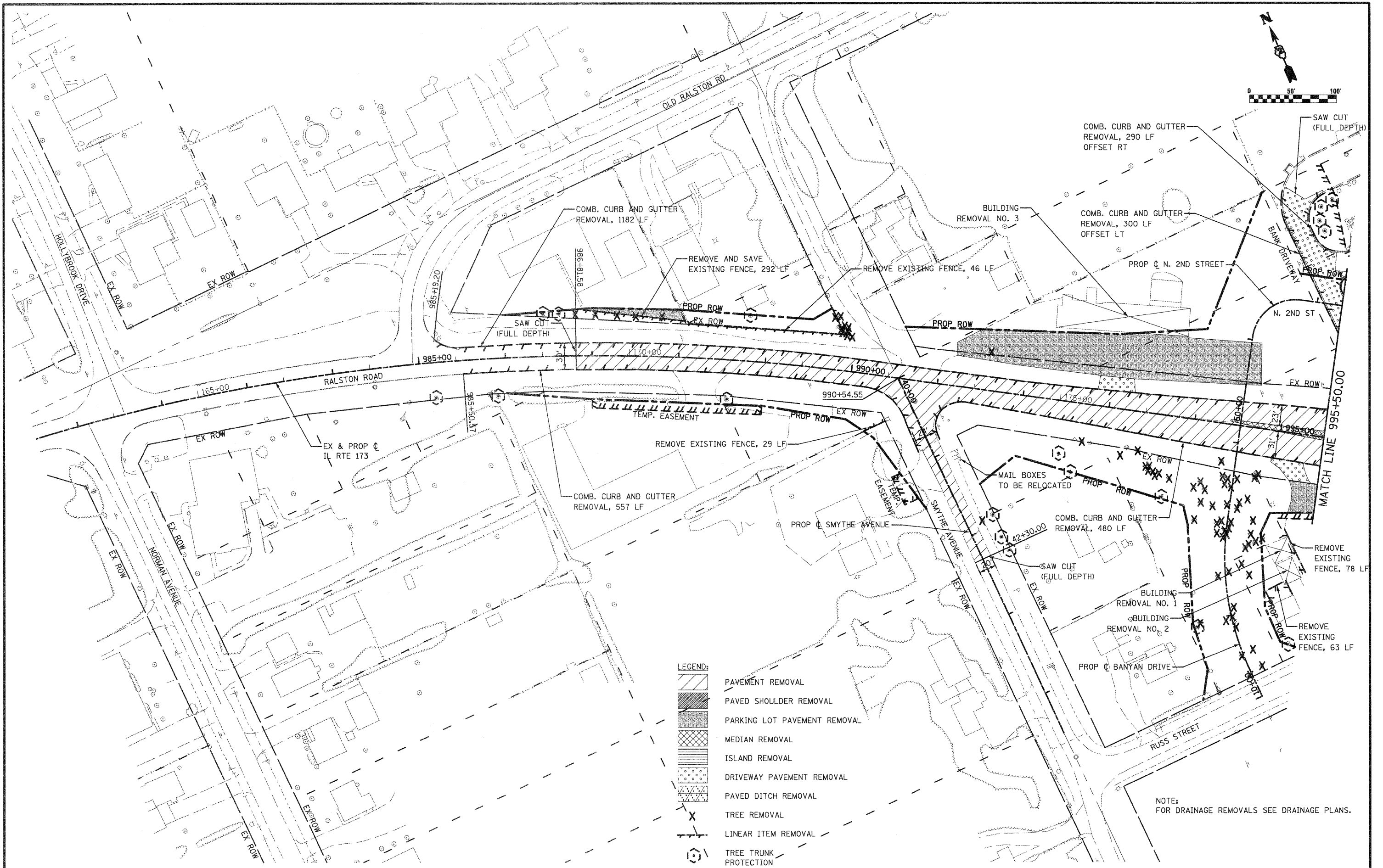

- LEGEND:**
- PAVEMENT REMOVAL
 - PAVED SHOULDER REMOVAL
 - PARKING LOT PAVEMENT REMOVAL
 - MEDIAN REMOVAL
 - ISLAND REMOVAL
 - DRIVEWAY PAVEMENT REMOVAL
 - PAVED DITCH REMOVAL
 - TREE REMOVAL
 - LINEAR ITEM REMOVAL
 - TREE TRUNK PROTECTION

NOTE:
FOR DRAINAGE REMOVALS SEE DRAINAGE PLANS.

FILE NAME = 0264987-shr-remove-01.dgn	USER NAME = 3202890971	DESIGNED - LOM	REVISED -	STATE OF ILLINOIS DEPARTMENT OF TRANSPORTATION	EXISTING AND REMOVAL PLAN RALSTON ROAD		F.A.P. RTE. 303	SECTION 129K-1	COUNTY WINNEBAGO	TOTAL SHEETS 401	SHEET NO. 55
	PLOT SCALE = 1/8" = 100'-0" IN.	DRAWN - MD	REVISED -		SCALE: _____	SHEET NO. _____ OF _____ SHEETS	STA. 980+50.00 TO STA. 995+50.00	FED. ROAD DIST. NO. 2 (ILLINOIS) FED. AID PROJECT			
PLOT DATE = 1/18/2011	CHECKED - PDK	DATE - 01-19-2011	REVISED -							CONTRACT NO. 64987	

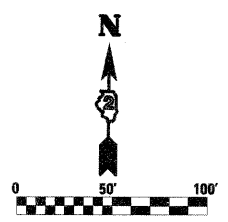
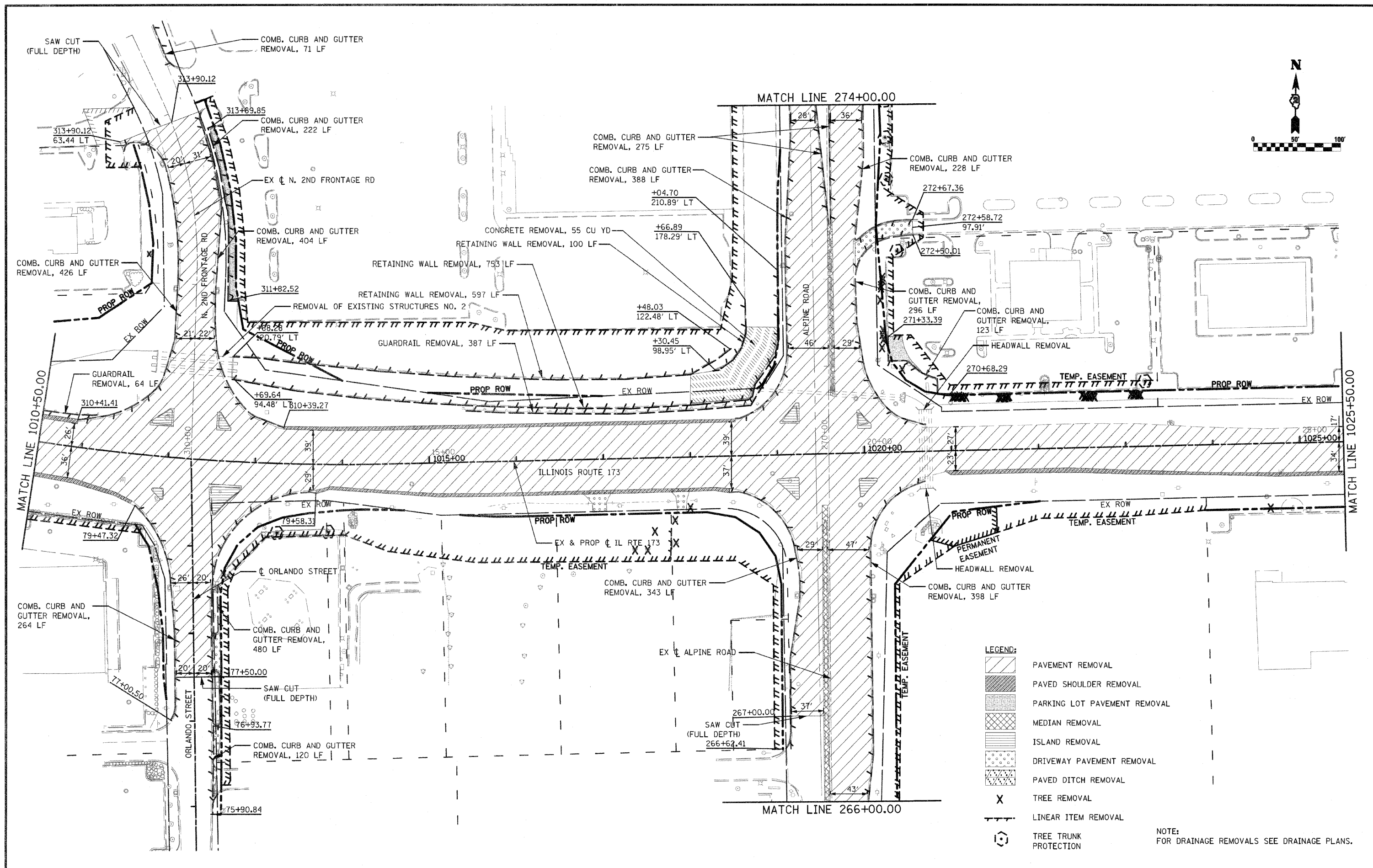

- LEGEND:**
- PAVEMENT REMOVAL
 - PAVED SHOULDER REMOVAL
 - PARKING LOT PAVEMENT REMOVAL
 - MEDIAN REMOVAL
 - ISLAND REMOVAL
 - DRIVEWAY PAVEMENT REMOVAL
 - PAVED DITCH REMOVAL
 - TREE REMOVAL
 - LINEAR ITEM REMOVAL
 - TREE TRUNK PROTECTION

NOTE:
FOR DRAINAGE REMOVALS SEE DRAINAGE PLANS.

FILE NAME = 0264987-shr-remove-83.dgn

USER NAME = 3282898771
 PLOT SCALE = 100.0000' / IN.
 PLOT DATE = 3/16/2011

DESIGNED - LOM
 DRAWN - MD
 CHECKED - PDK
 DATE - 03-16-2011

REVISED -
 REVISED -
 REVISED -
 REVISED -

**STATE OF ILLINOIS
 DEPARTMENT OF TRANSPORTATION**

**EXISTING AND REMOVAL PLAN
 ILLINOIS ROUTE 173**
 SCALE: SHEET NO. OF SHEETS STA. 1010+50.00 TO STA. 1025+50.00



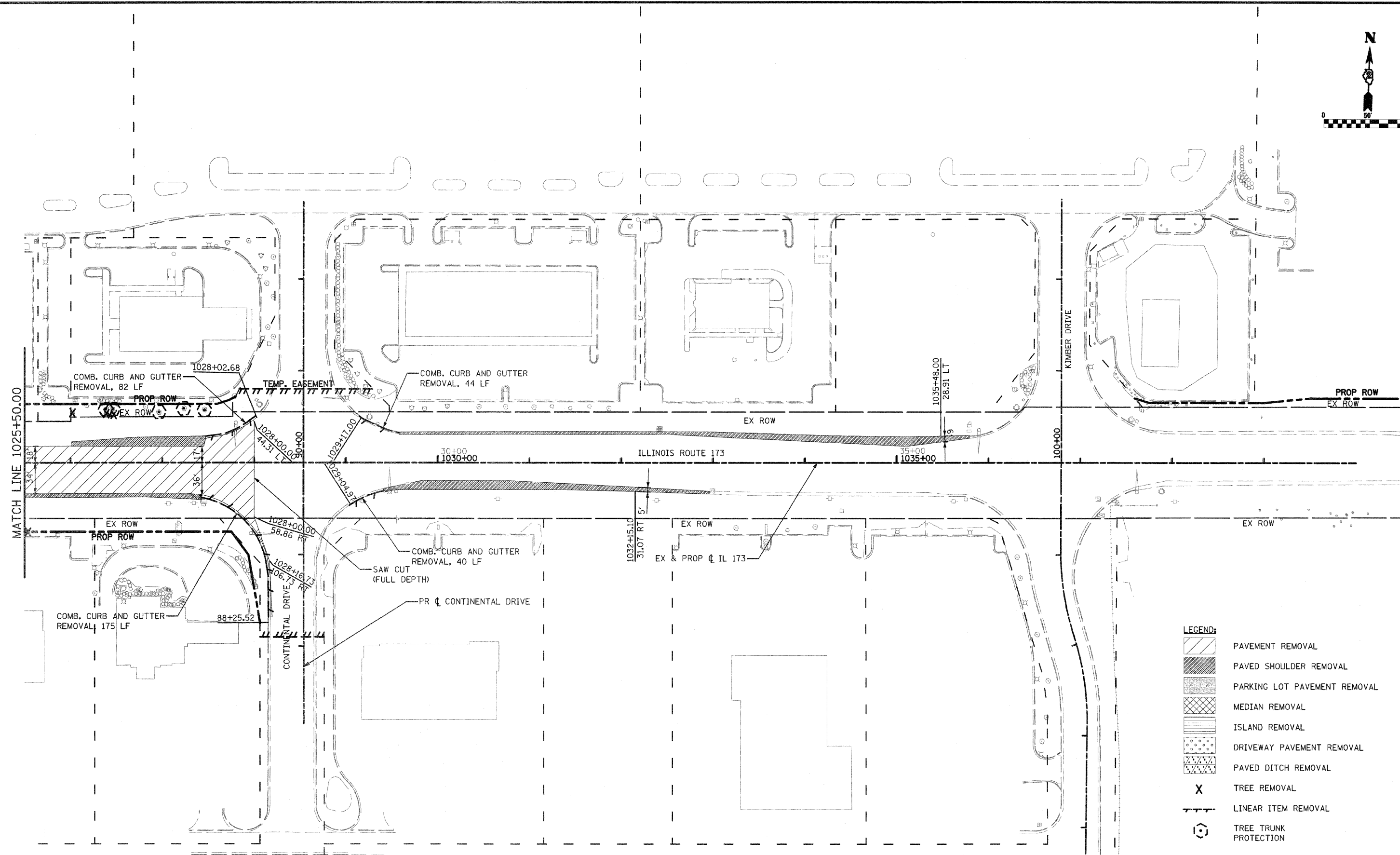
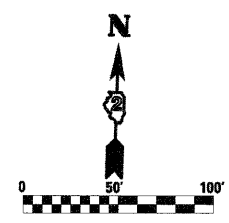







F.A.P. RTE.	SECTION	COUNTY	TOTAL SHEETS	SHEET NO.
303	129K-1	WINNEBAGO	401	57
CONTRACT NO. 64987				
FED. ROAD DIST. NO. 2 ILLINOIS FED. AID PROJECT				



- LEGEND:**
- PAVEMENT REMOVAL
 - PAVED SHOULDER REMOVAL
 - PARKING LOT PAVEMENT REMOVAL
 - MEDIAN REMOVAL
 - ISLAND REMOVAL
 - DRIVEWAY PAVEMENT REMOVAL
 - PAVED DITCH REMOVAL
 - TREE REMOVAL
 - LINEAR ITEM REMOVAL
 - TREE TRUNK PROTECTION

NOTE:
FOR DRAINAGE REMOVALS SEE DRAINAGE PLANS.

FILE NAME = 0264987-shr-remove-04.dgn	USER NAME = 3202090771	DESIGNED - LOM	REVISED -	STATE OF ILLINOIS DEPARTMENT OF TRANSPORTATION	EXISTING AND REMOVAL PLAN ILLINOIS ROUTE 173	F.A.P. RTE. 303	SECTION 129K-1	COUNTY WINNEBAGO	TOTAL SHEETS 401	SHEET NO. 58	
PILOT SCALE = 100.0000' / 1" IN.		DRAWN - MD	REVISED -			SCALE: SHEET NO. OF SHEETS STA. 1025+50.00 TO STA. 1040+00.00					
PLOT DATE = 3/16/2011		CHECKED - PDK	REVISED -			FED. ROAD DIST. NO. 2 ILLINOIS FED. AID PROJECT					
		DATE - 03-16-2011	REVISED -			CONTRACT NO. 64987					

- LEGEND:**
-  PAVEMENT REMOVAL
 -  PAVED SHOULDER REMOVAL
 -  PARKING LOT PAVEMENT REMOVAL
 -  MEDIAN REMOVAL
 -  ISLAND REMOVAL
 -  DRIVEWAY PAVEMENT REMOVAL
 -  PAVED DITCH REMOVAL
 -  TREE REMOVAL
 -  LINEAR ITEM REMOVAL
 -  TREE TRUNK PROTECTION

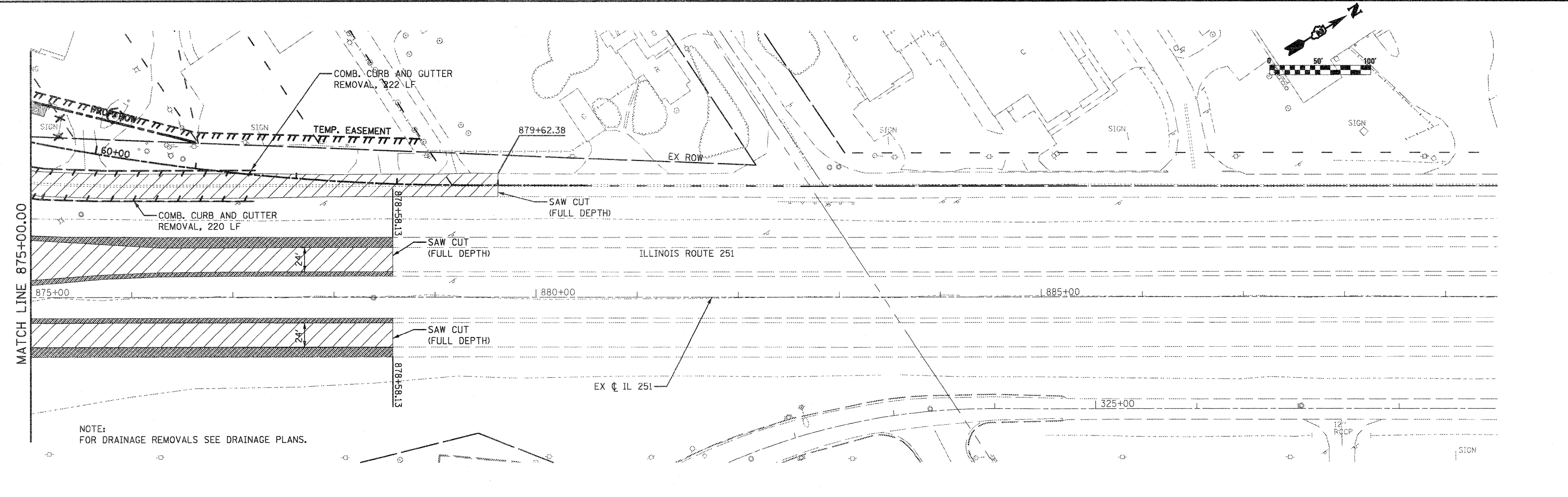
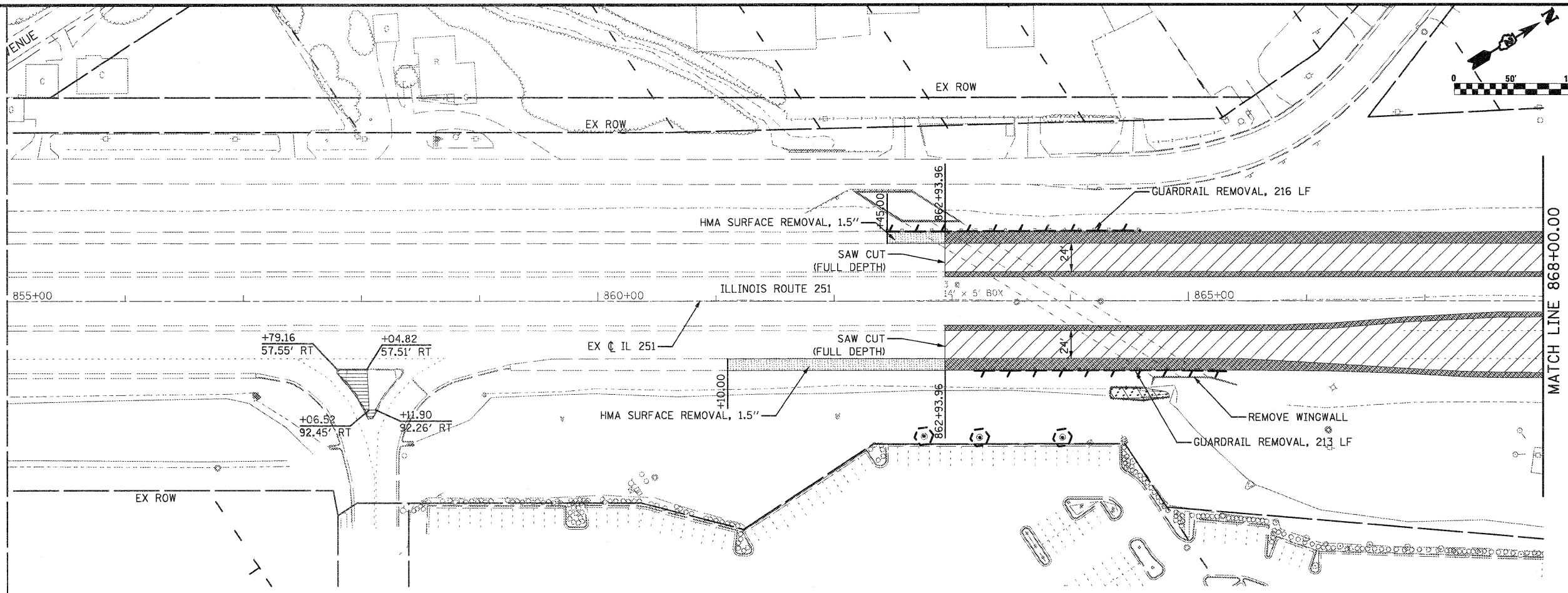

NOTE:
FOR DRAINAGE REMOVALS SEE DRAINAGE PLANS.

FILE NAME = 0264987-shr-remove-05.dgn

USER NAME = 3202090971
 PLOT SCALE = 100,0000 / IN.
 PLOT DATE = 1/18/2011

DESIGNED - LOM
 DRAWN - MD
 CHECKED - PDK
 DATE - 01-19-2011

REVISED -
 REVISED -
 REVISED -
 REVISED -

**STATE OF ILLINOIS
 DEPARTMENT OF TRANSPORTATION**

**EXISTING AND REMOVAL PLAN
 ILLINOIS ROUTE 251**

SCALE: SHEET NO. OF SHEETS STA. 855+00.00 TO STA. 889+00.00

F.A.P. RTE.	SECTION	COUNTY	TOTAL SHEETS	SHEET NO.
303	129K-1	WINNEBAGO	401	59

CONTRACT NO. 64987
 FED. ROAD DIST. NO. 2 ILLINOIS FED. AID PROJECT

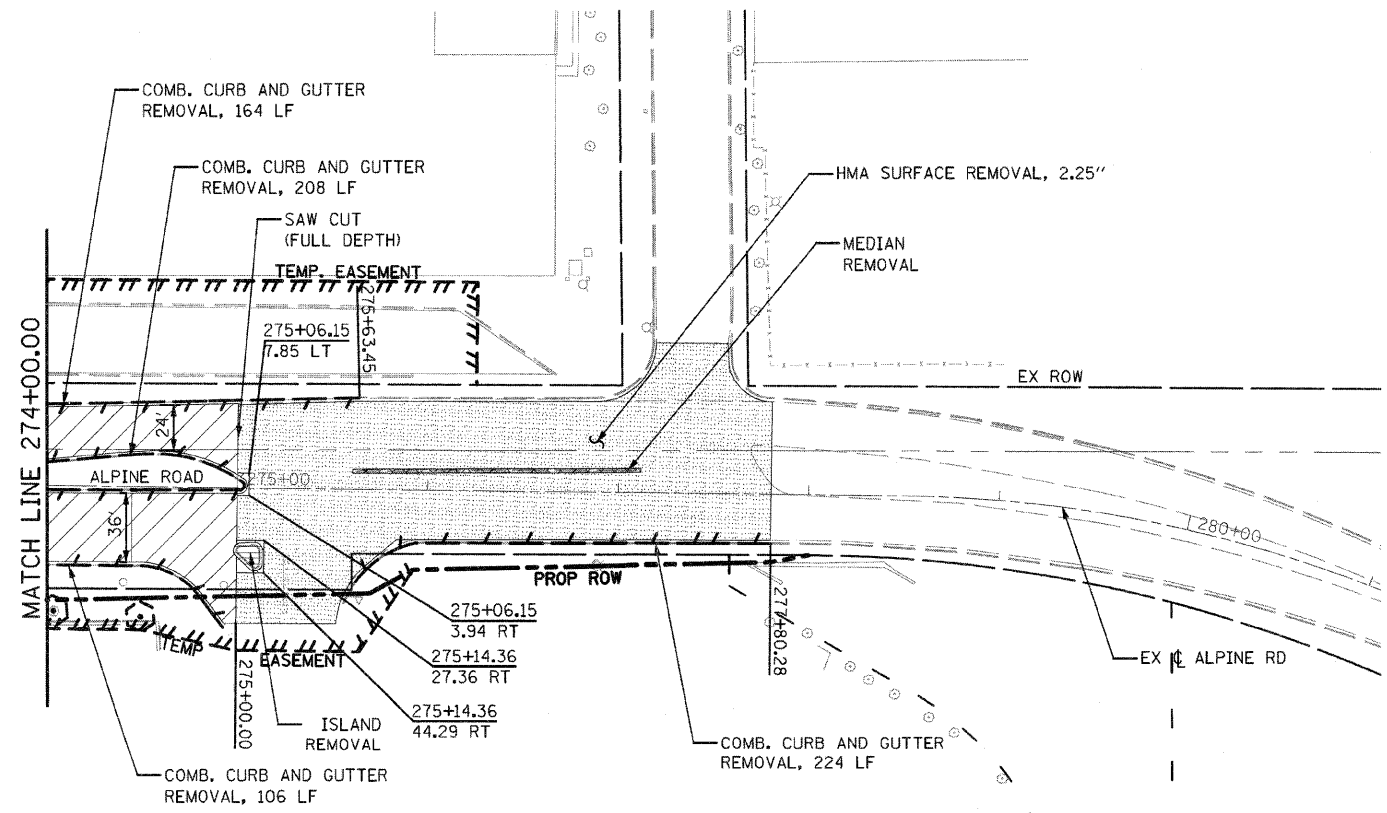
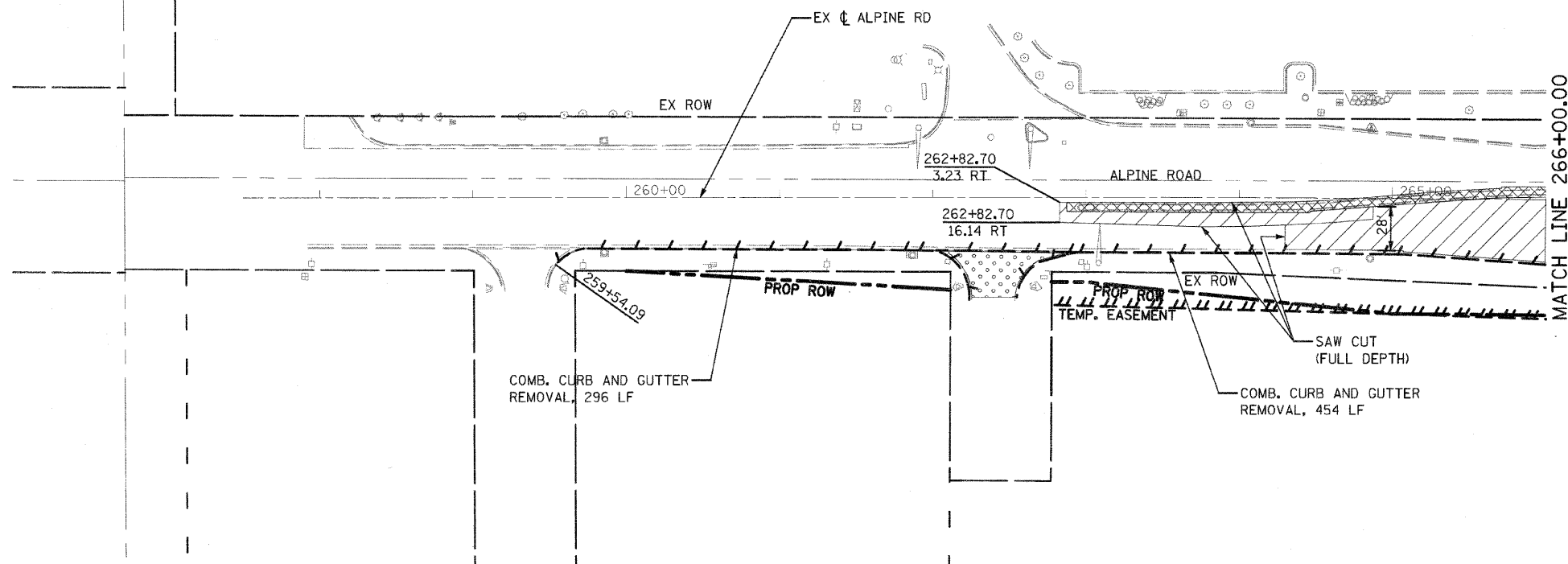

- LEGEND:**
- PAVEMENT REMOVAL
 - PAVED SHOULDER REMOVAL
 - PARKING LOT PAVEMENT REMOVAL
 - MEDIAN REMOVAL
 - ISLAND REMOVAL
 - DRIVEWAY PAVEMENT REMOVAL
 - PAVED DITCH REMOVAL
 - TREE REMOVAL
 - LINEAR ITEM REMOVAL
 - TREE TRUNK PROTECTION

FILE NAME = 0264987-shr-remove-05.dgn

USER NAME = 3202090971
 PLOT SCALE = 100.0000' / 1" IN.
 PLOT DATE = 3/16/2011

DESIGNED - LOM
 DRAWN - MD
 CHECKED - PDK
 DATE - 03-16-2011

REVISED -
 REVISED -
 REVISED -
 REVISED -

**STATE OF ILLINOIS
 DEPARTMENT OF TRANSPORTATION**

**EXISTING AND REMOVAL PLAN
 ALPINE ROAD**

SCALE: SHEET NO. OF SHEETS STA. 274+00.00 TO STA. 281+00.00

F.A.P. RTE.	SECTION	COUNTY	TOTAL SHEETS	SHEET NO.
303	129K-1	WINNEBAGO	401	60

CONTRACT NO. 64987
 FED. ROAD DIST. NO. 2 ILLINOIS FED. AID PROJECT

STA. 994+52.77 (PR C IL 173)=
 STA. 13+20.20 (PR C BANYAN DR)=
 STA. 50+00.00 (PR C N. 2ND ST)

PROP. CURVE G52320
 PI STA. = 2146+14.26
 $\Delta = 15^\circ 00' 23''$ (LT)
 $D = 5^\circ 49' 22''$
 $R = 984.00'$
 $L = 129.60'$
 $T = 257.72'$
 $E = 8.50'$
 $\phi = N.C.$
 T.R. = N/A
 S.E. RUN = N/A
 P.C. STA. = 2144+84.66
 P.T. STA. = 2147+42.38

PROP. CURVE 70210
 PI STA. = 1002+67.70
 $\Delta = 15^\circ 00' 23''$ (LT)
 $D = 5^\circ 43' 46''$
 $R = 1,000.00'$
 $L = 131.71'$
 $T = 261.91'$
 $E = 8.64'$
 $\phi = N.C.$
 T.R. = N/A
 S.E. RUN = N/A
 P.C. STA. = 1001+35.99
 P.T. STA. = 1003+97.90

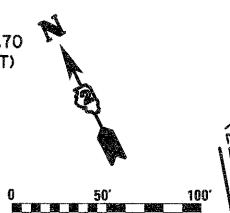

PLAN	SURVEYED	DATE
	PLOTTED	
	CHECKED	
	BY	
	DATE	

PROFILE	SURVEYED	DATE
	PLOTTED	
	CHECKED	
	BY	
	DATE	

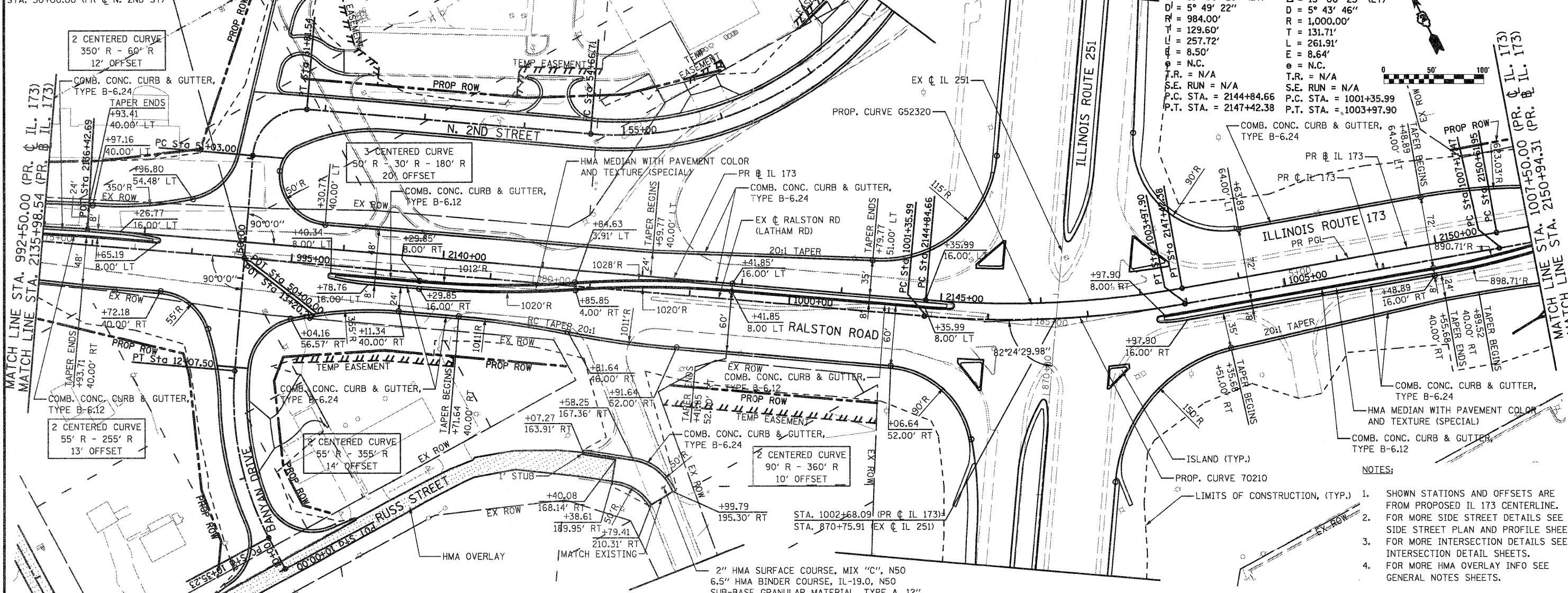

- NOTES:
1. SHOWN STATIONS AND OFFSETS ARE FROM PROPOSED IL 173 CENTERLINE.
 2. FOR MORE SIDE STREET DETAILS SEE SIDE STREET PLAN AND PROFILE SHEETS.
 3. FOR MORE INTERSECTION DETAILS SEE INTERSECTION DETAIL SHEETS.
 4. FOR MORE HMA OVERLAY INFO SEE GENERAL NOTES SHEETS.

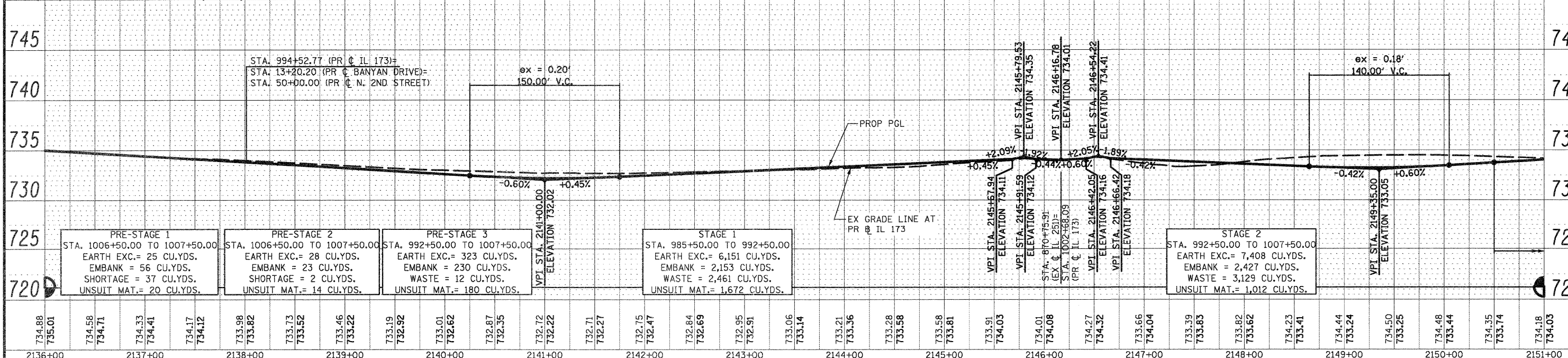

PRE-STAGE 1 STA. 1006+50.00 TO 1007+50.00 EARTH EXC. = 25 CU.YDS. EMBANK = 56 CU.YDS. SHORTAGE = 37 CU.YDS. UNSUIT MAT. = 20 CU.YDS.	PRE-STAGE 2 STA. 1006+50.00 TO 1007+50.00 EARTH EXC. = 28 CU.YDS. EMBANK = 230 CU.YDS. SHORTAGE = 2 CU.YDS. UNSUIT MAT. = 14 CU.YDS.	PRE-STAGE 3 STA. 992+50.00 TO 1007+50.00 EARTH EXC. = 323 CU.YDS. EMBANK = 230 CU.YDS. WASTE = 12 CU.YDS. UNSUIT MAT. = 180 CU.YDS.	STAGE 1 STA. 985+50.00 TO 992+50.00 EARTH EXC. = 6,151 CU.YDS. EMBANK = 2,153 CU.YDS. WASTE = 2,461 CU.YDS. UNSUIT MAT. = 1,672 CU.YDS.	STAGE 2 STA. 992+50.00 TO 1007+50.00 EARTH EXC. = 7,408 CU.YDS. EMBANK = 2,427 CU.YDS. WASTE = 3,129 CU.YDS. UNSUIT MAT. = 1,012 CU.YDS.
---	---	--	--	---

FILE NAME = 0264987-ah-t-pln-prf-02.dgn	USER NAME = 328289971	DESIGNED - LOM	REVISED -	PLAN AND PROFILE				F.A.P. RTE. = 303	SECTION = 129K-1	COUNTY = WINNEBAGO	TOTAL SHEETS = 401	SHEET NO. = 62
STATE OF ILLINOIS DEPARTMENT OF TRANSPORTATION				RALSTON ROAD \ ILLINOIS ROUTE 173				CONTRACT NO. 64987				
SCALE: SHEET NO. OF SHEETS				STA. 992+50.00 TO STA. 1007+50.00				FED. ROAD DIST. NO. 2 ILLINOIS FED. AID PROJECT				

DATE	
BY	
REVISIONS	
NO.	
DESCRIPTION	
DATE	
BY	
REVISIONS	
NO.	
DESCRIPTION	
DATE	
BY	
REVISIONS	
NO.	
DESCRIPTION	
DATE	
BY	
REVISIONS	
NO.	
DESCRIPTION	

DATE	
BY	
REVISIONS	
NO.	
DESCRIPTION	
DATE	
BY	
REVISIONS	
NO.	
DESCRIPTION	
DATE	
BY	
REVISIONS	
NO.	
DESCRIPTION	

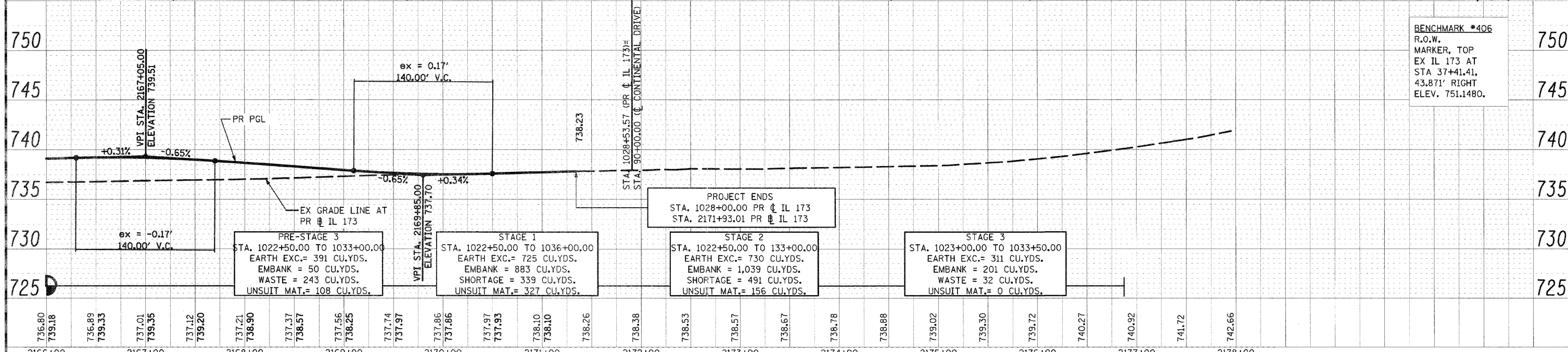
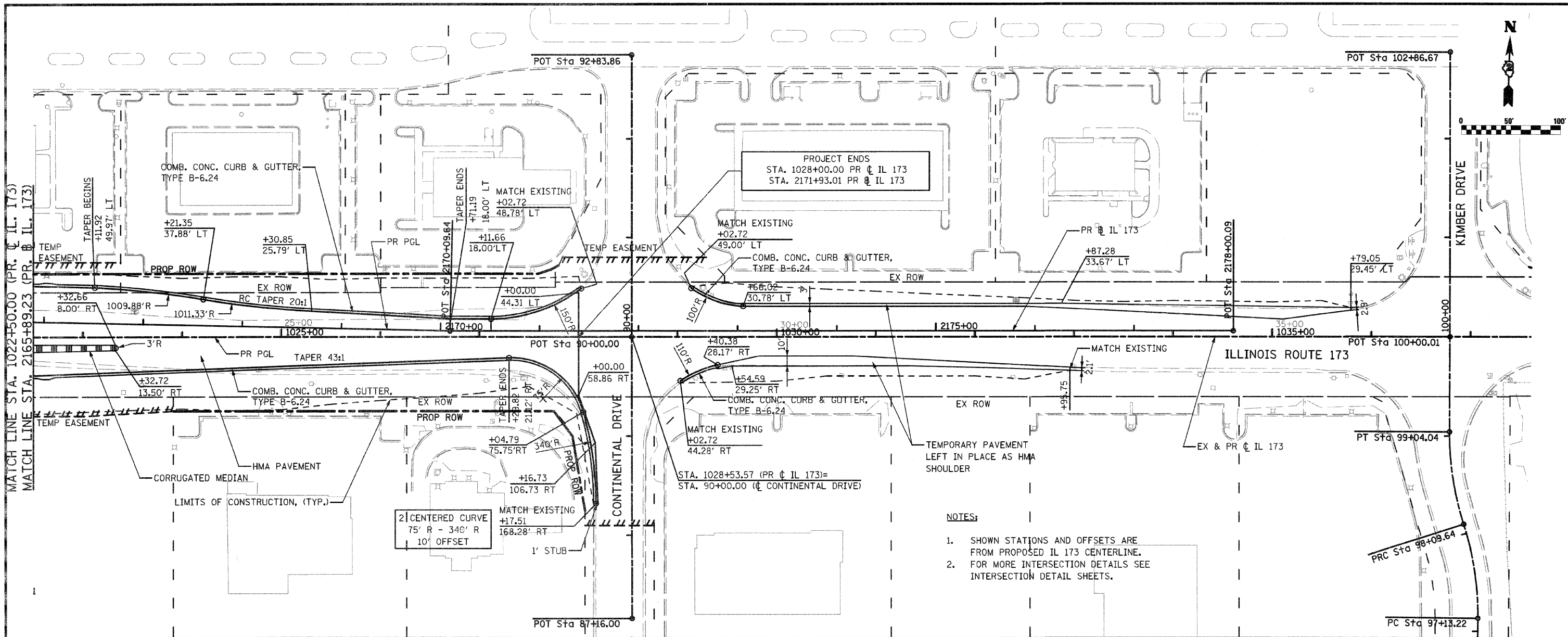

- NOTES:**
1. SHOWN STATIONS AND OFFSETS ARE FROM PROPOSED IL 173 CENTERLINE.
 2. FOR MORE INTERSECTION DETAILS SEE INTERSECTION DETAIL SHEETS.

FILE NAME = 0264987-shr-plnprf-04.dgn	USER NAME = 320209071	DESIGNED - LOM	REVISED -	STATE OF ILLINOIS DEPARTMENT OF TRANSPORTATION	PLAN AND PROFILE ILLINOIS ROUTE 173	F.A.P. RTE. 303	SECTION 129K-1	COUNTY WINNEBAGO	TOTAL SHEETS 401	SHEET NO. 64
PLOT SCALE = 1/8" = 100.0000' / IN.	CHECKED - PDK	REVISOR -	REVISOR -			CONTRACT NO. 64987				
PLOT DATE = 3/16/2011	DATE - 03-16-2011	REVISOR -	REVISOR -			FED. ROAD DIST. NO. 2 ILLINOIS FED. AID PROJECT				
SCALE:		SHEET NO. OF SHEETS				STA. 1022+50.00 TO STA. 1037+50.00				

DATE: _____
 BY: _____
 SURVEYED _____
 PLOTTED _____
 CHECKED _____
 NOTE BOOK NO. _____
 RT. OF WAY CHECKED _____
 CAD FILE NAME _____

DATE: _____
 BY: _____
 PROFILE SURVEYED _____
 PLOTTED _____
 CHECKED _____
 NOTE BOOK NO. _____
 STRUCTURE NOTATIONS CHKD _____

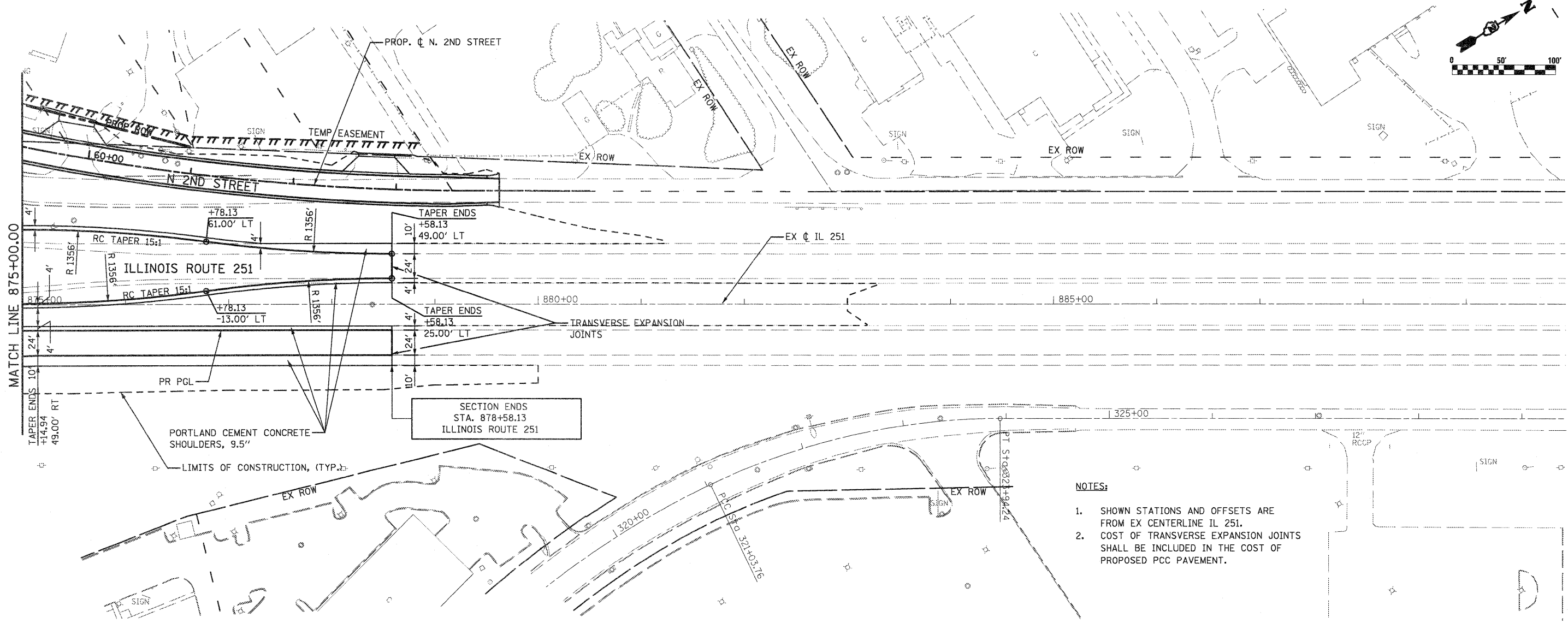

- NOTES:**
1. SHOWN STATIONS AND OFFSETS ARE FROM EX CENTERLINE IL 251.
 2. COST OF TRANSVERSE EXPANSION JOINTS SHALL BE INCLUDED IN THE COST OF PROPOSED PCC PAVEMENT.

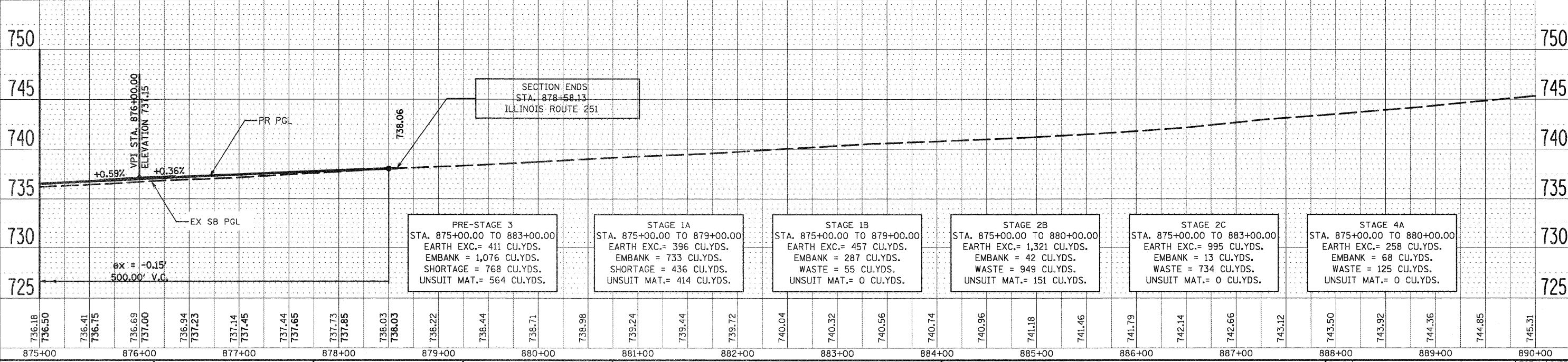

PRE-STAGE 3 STA. 875+00.00 TO 883+00.00 EARTH EXC.= 411 CU.YDS. EMBANK = 1,076 CU.YDS. SHORTAGE = 768 CU.YDS. UNSUIT MAT.= 564 CU.YDS.	STAGE 1A STA. 875+00.00 TO 879+00.00 EARTH EXC.= 396 CU.YDS. EMBANK = 733 CU.YDS. SHORTAGE = 436 CU.YDS. UNSUIT MAT.= 414 CU.YDS.	STAGE 1B STA. 875+00.00 TO 879+00.00 EARTH EXC.= 457 CU.YDS. EMBANK = 287 CU.YDS. WASTE = 55 CU.YDS. UNSUIT MAT.= 0 CU.YDS.	STAGE 2B STA. 875+00.00 TO 880+00.00 EARTH EXC.= 1,321 CU.YDS. EMBANK = 42 CU.YDS. WASTE = 949 CU.YDS. UNSUIT MAT.= 151 CU.YDS.	STAGE 2C STA. 875+00.00 TO 883+00.00 EARTH EXC.= 995 CU.YDS. EMBANK = 13 CU.YDS. WASTE = 734 CU.YDS. UNSUIT MAT.= 0 CU.YDS.	STAGE 4A STA. 875+00.00 TO 880+00.00 EARTH EXC.= 258 CU.YDS. EMBANK = 68 CU.YDS. WASTE = 125 CU.YDS. UNSUIT MAT.= 0 CU.YDS.
--	---	---	---	---	---

736.18	736.50	736.41	736.75	736.69	737.00	736.94	737.23	737.14	737.45	737.44	737.65	737.73	737.85	738.03	738.03	738.22	738.44	738.71	738.98	739.24	739.44	739.72	740.04	740.32	740.56	740.74	740.96	741.18	741.46	741.79	742.14	742.66	743.12	743.50	743.92	744.36	744.85	745.31
875+00	876+00	877+00	878+00	879+00	880+00	881+00	882+00	883+00	884+00	885+00	886+00	887+00	888+00	889+00	890+00																							

FILE NAME = D264987-shb:plnprf-09.dgn

USER NAME = 320289971
 PLOT SCALE = 100.0000' / IN.
 PLOT DATE = 1/18/2011

DESIGNED - LOM
 DRAWN - MG
 CHECKED - PDK
 DATE - 01-19-2011

REVISED -
 REVISED -
 REVISED -
 REVISED -

**STATE OF ILLINOIS
 DEPARTMENT OF TRANSPORTATION**

**PLAN AND PROFILE
 ILLINOIS ROUTE 251**
 SCALE: _____ SHEET NO. _____ OF _____ SHEETS STA. 875+00.00 TO STA. 878+58.13

F.A.P. RTE. 303	SECTION 129K-1	COUNTY WINNEBAGO	TOTAL SHEETS 401	SHEET NO. 69
CONTRACT NO. 64987				

FED. ROAD DIST. NO. 2 ILLINOIS FED. AID PROJECT

PLAN	SURVEYED	BY	DATE
	PLOTTED		
	NOTED		
	FILED		
	NO. OF WAY CHECKED		
	PAID FILE NAME		

PROFILE	SEWERED	BY	DATE
	PLOTTED		
	CHECKED		
	STRUCTURE		
	NOTATIONS		
	CHKD		

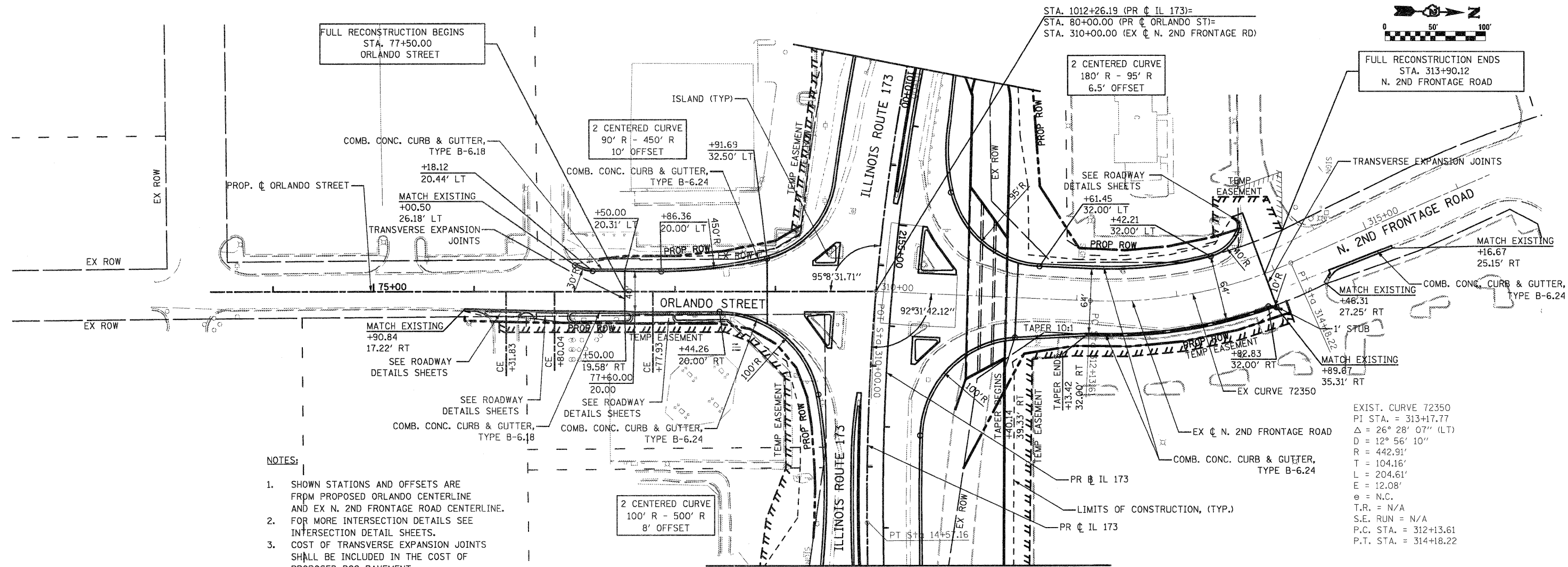

- NOTES:**
1. SHOWN STATIONS AND OFFSETS ARE FROM PROPOSED ORLANDO CENTERLINE AND EX N. 2ND FRONTAGE ROAD CENTERLINE.
 2. FOR MORE INTERSECTION DETAILS SEE INTERSECTION DETAIL SHEETS.
 3. COST OF TRANSVERSE EXPANSION JOINTS SHALL BE INCLUDED IN THE COST OF PROPOSED PCC PAVEMENT.
 4. FOR MORE DRIVEWAY INFORMATION SEE DISTRICT 2 STANDARD 25.1.

EXIST. CURVE 72350
 PI STA. = 313+17.77
 $\Delta = 26^\circ 28' 07''$ (LT)
 R = 442.91'
 T = 104.16'
 L = 204.61'
 E = 12.08'
 $\theta =$ N.C.
 T.R. = N/A
 S.E. RUN = N/A
 P.C. STA. = 312+13.61
 P.T. STA. = 314+18.22

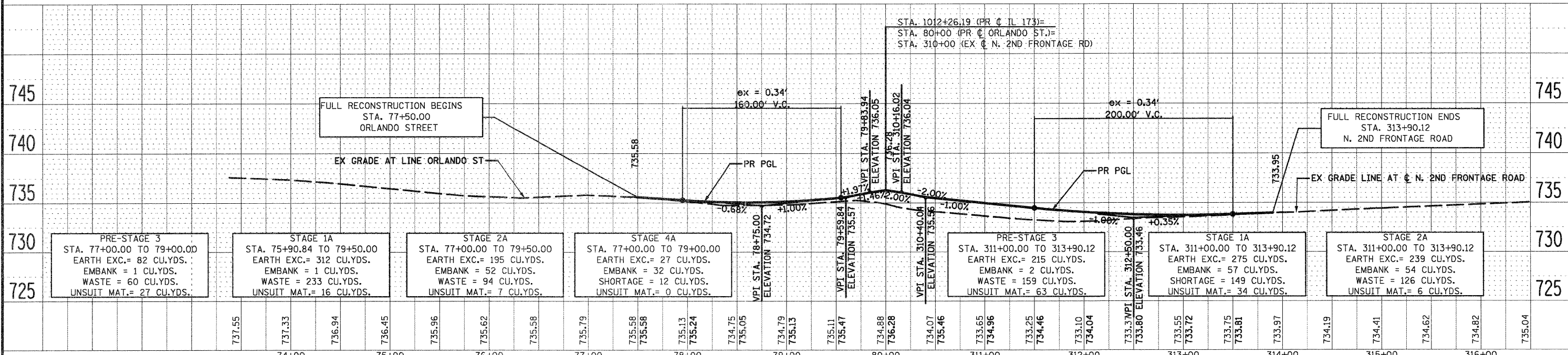

FILE NAME = 0264987-shr-plnprf-10.dgn	USER NAME = 3292098971	DESIGNED - LOM	REVISED -	STATE OF ILLINOIS DEPARTMENT OF TRANSPORTATION	PLAN AND PROFILE ORLANDO STREET \ N 2ND FRONTAGE ROAD	F.A.P. RTE. = 303	SECTION = 129K-1	COUNTY = WINNEBAGO	TOTAL SHEETS = 401	SHEET NO. = 70		
	PLOT SCALE = 100.0000' / IN.	DRAWN - MG	REVISED -			SCALE:	SHEET NO. OF SHEETS	STA. 77+50.00 TO STA. 313+90.00	FED. ROAD DIST. NO. 2 ILLINOIS FED. AID PROJECT			
	PLOT DATE = 1/18/2011	CHECKED - PDK	REVISED -			CONTRACT NO. 64987						
		DATE - 01-19-2011	REVISED -									

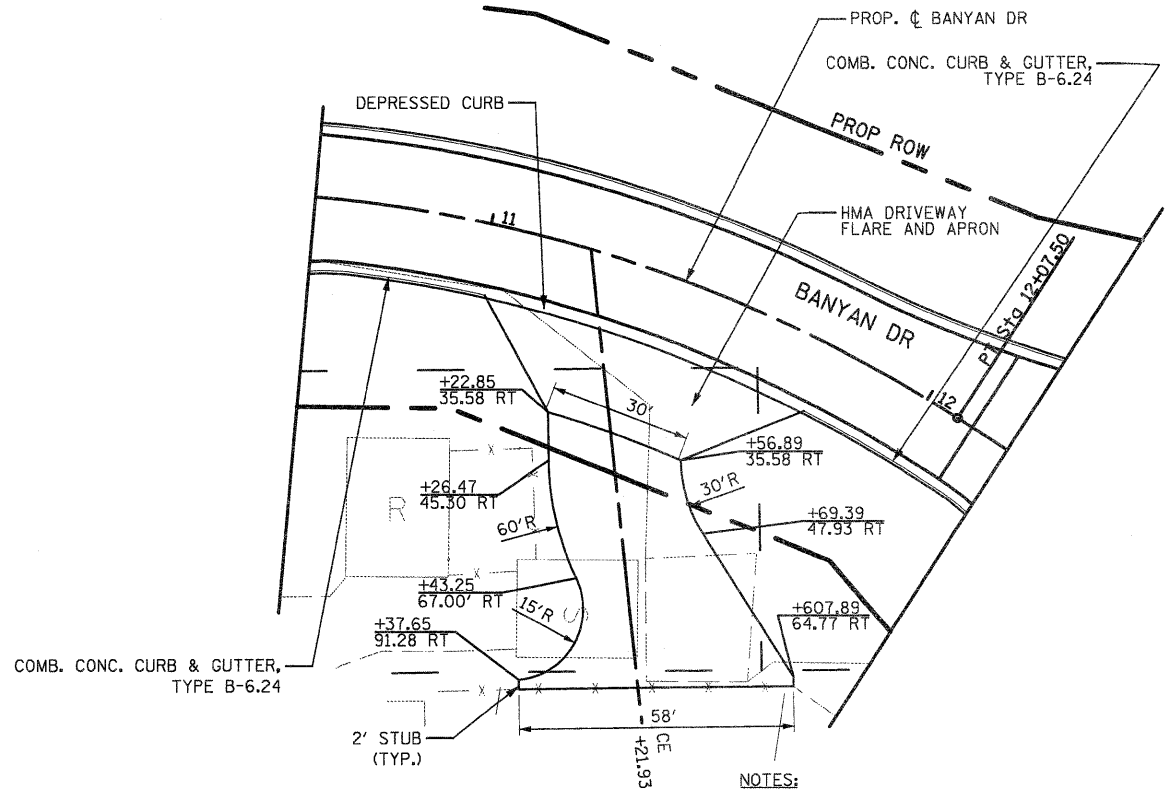

BANYAN DR DRIVEWAY
STA. 11+21.93

- NOTES:**
1. SHOWN STATIONS AND OFFSET ARE FROM PROPOSED BANYAN CENTERLINE.
 2. DEPRESSED CURB SHALL BE PAID AS FOR ADJACENT TYPE CURB AND GUTTER.
 3. FOR MORE DRIVEWAY INFORMATION SEE DISTRICT 2 STANDARD 25.1.

POINT	①	②	③	④	⑤	⑥	⑦
STA.	+52.20	+59.35	+64.38	+68.04	+70.89	+73.99	+75.18
OFF.	28.75 LT	44.51 LT	61.63 LT	79.58 LT	97.96 LT	115.41 LT	121.25 LT
ELEV.	732.41	732.54	732.92	733.33	733.74	734.08	734.14

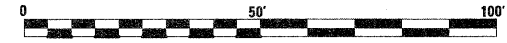
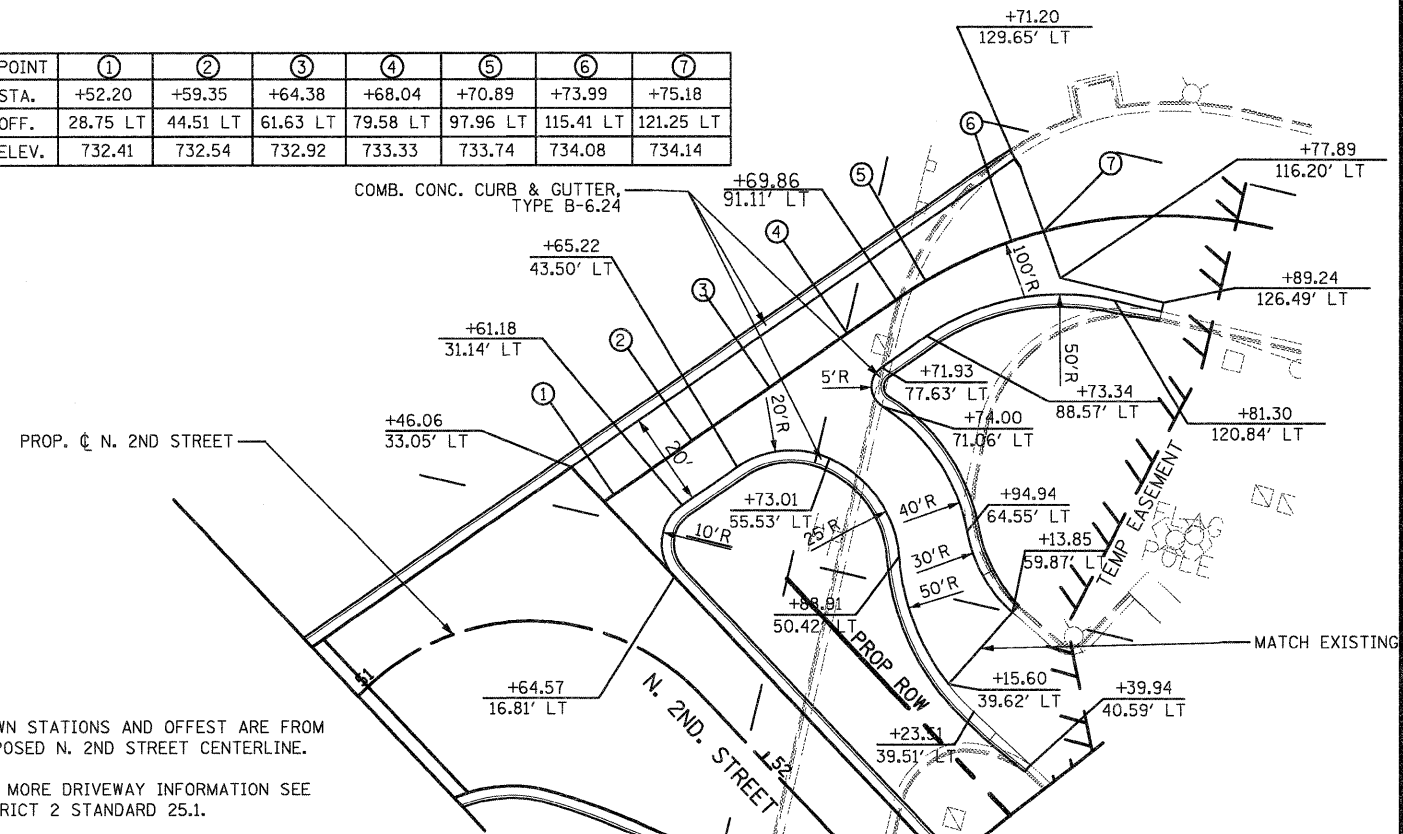

BANK DRIVEWAY
DETAIL

- NOTE:**
1. SHOWN STATIONS AND OFFSET ARE FROM PROPOSED N. 2ND STREET CENTERLINE.
 2. FOR MORE DRIVEWAY INFORMATION SEE DISTRICT 2 STANDARD 25.1.

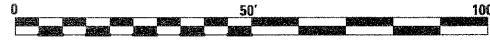
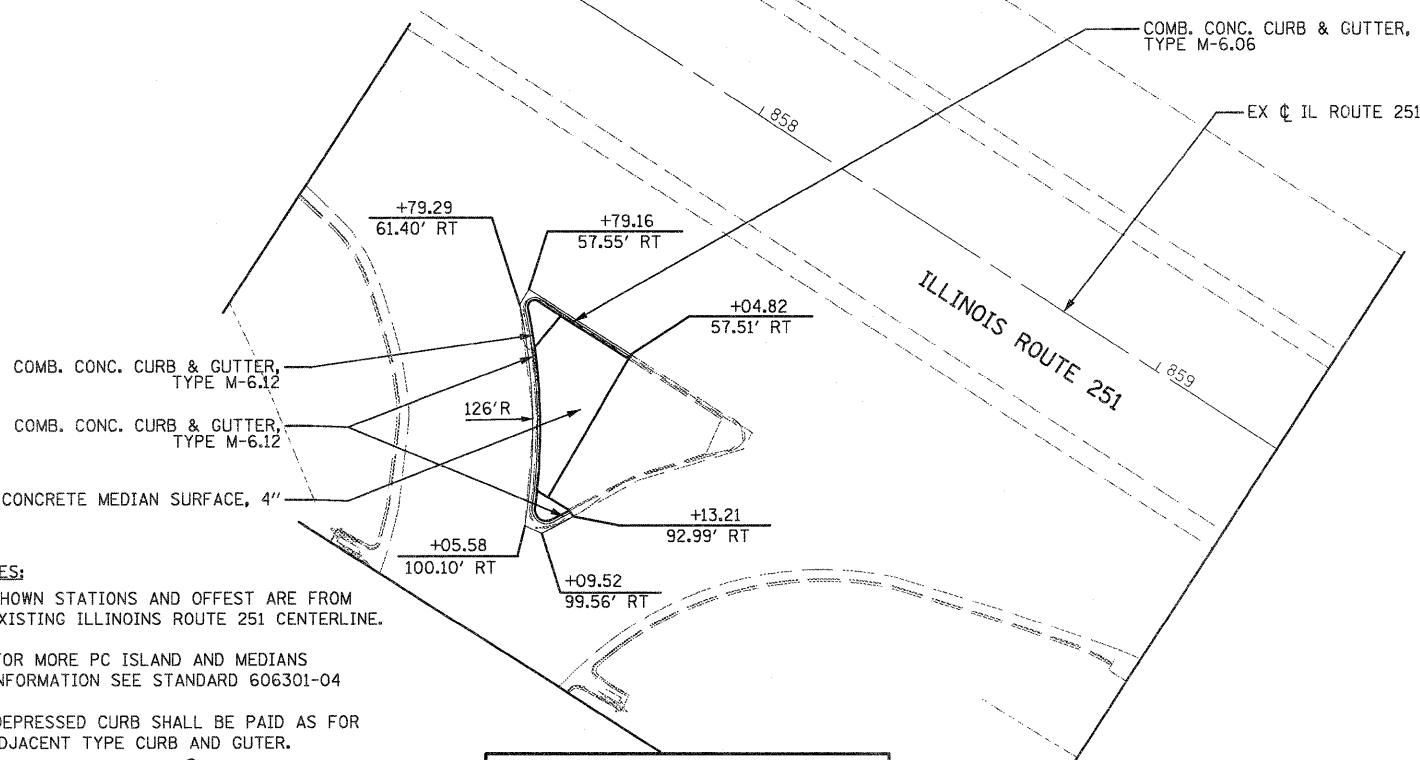

IL ROUTE 251
STA. 857+79.16

- NOTES:**
1. SHOWN STATIONS AND OFFSET ARE FROM EXISTING ILLINOIS ROUTE 251 CENTERLINE.
 2. FOR MORE PC ISLAND AND MEDIANS INFORMATION SEE STANDARD 606301-04.
 2. DEPRESSED CURB SHALL BE PAID AS FOR ADJACENT TYPE CURB AND GUTTER.

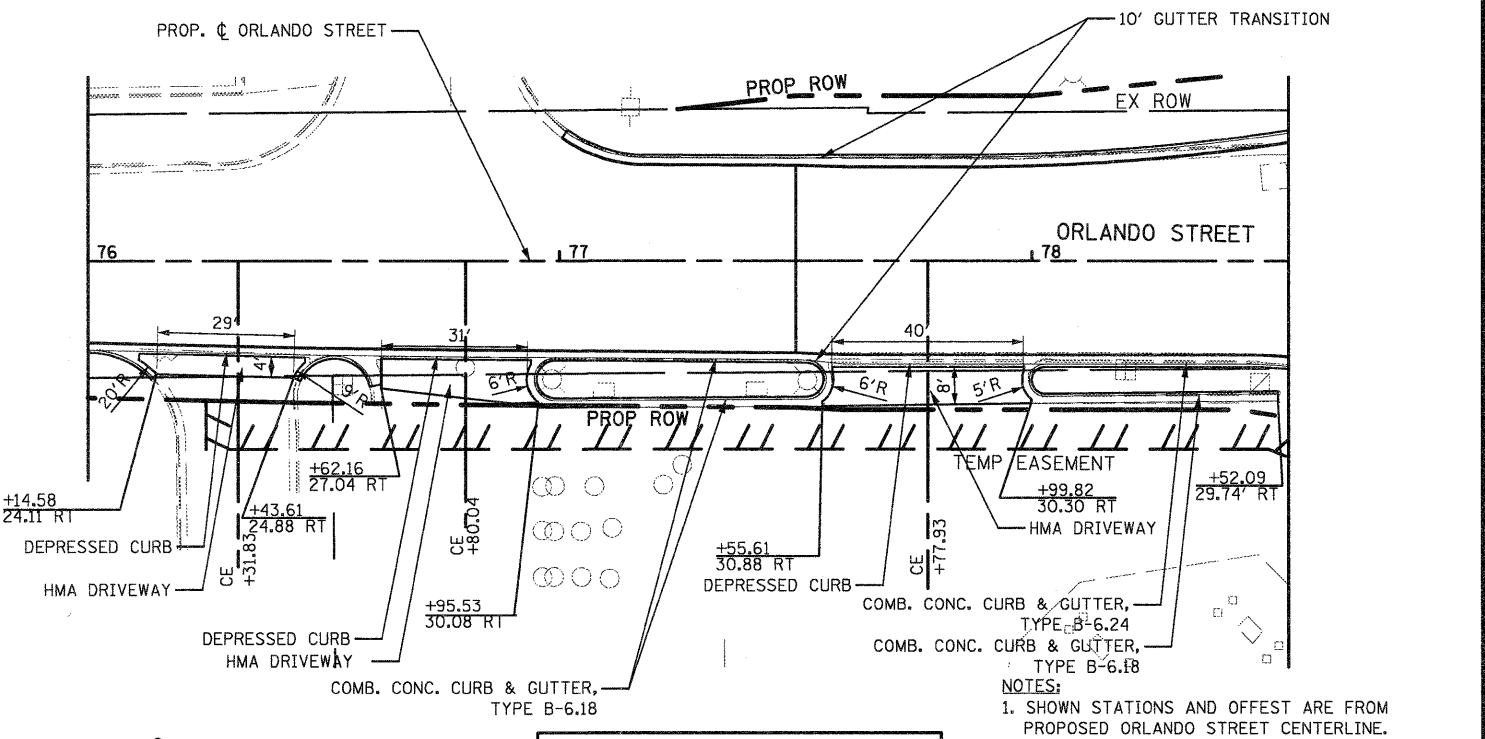

ORLANDO ST DRIVEWAYS
STA. 76+31.83
STA. 76+80.04
STA. 77+77.93

- NOTES:**
1. SHOWN STATIONS AND OFFSET ARE FROM PROPOSED ORLANDO STREET CENTERLINE.
 2. DEPRESSED CURB SHALL BE PAID AS FOR ADJACENT TYPE CURB AND GUTTER.
 3. FOR MORE DRIVEWAY INFORMATION SEE DISTRICT 2 STANDARD 25.1.

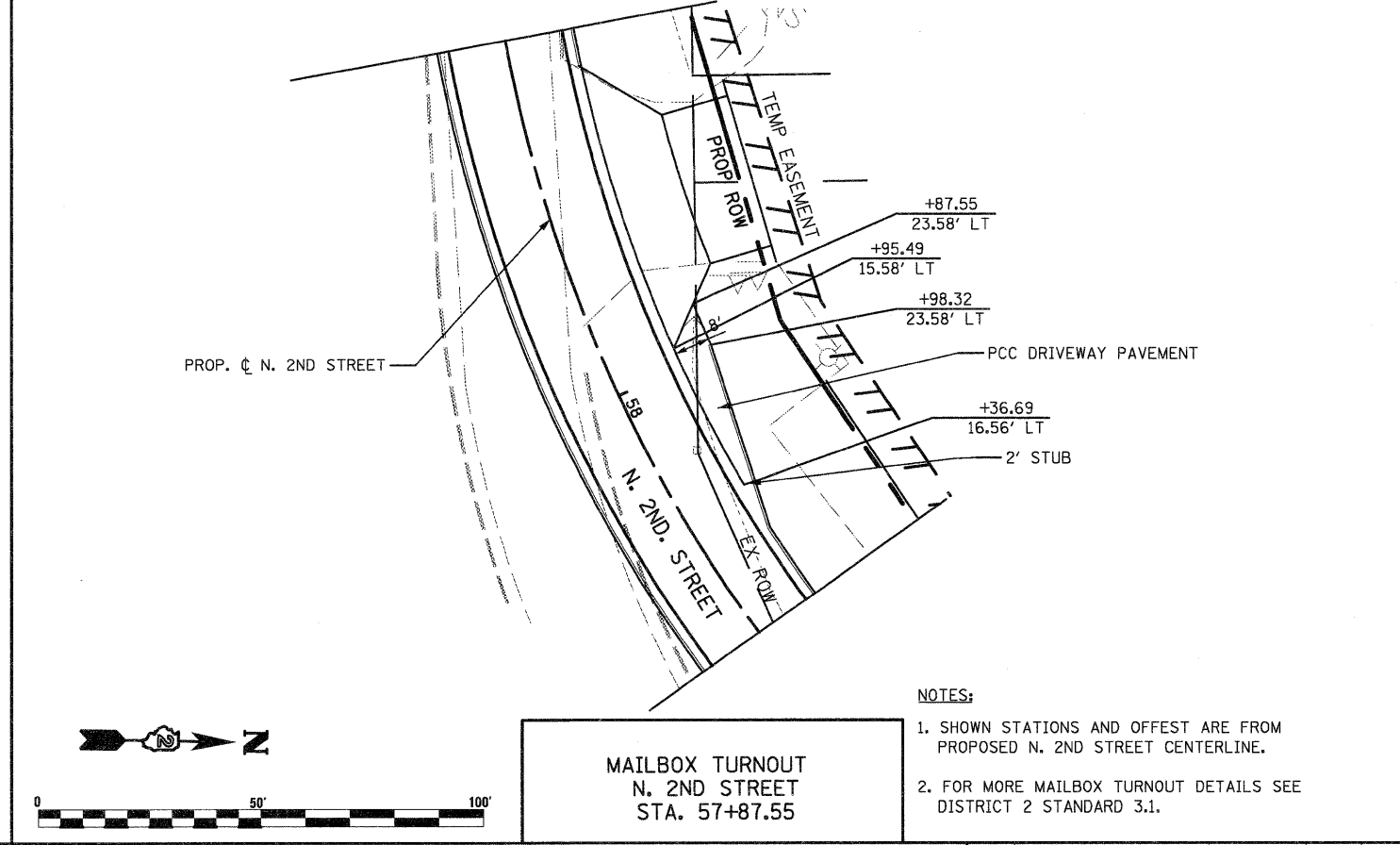
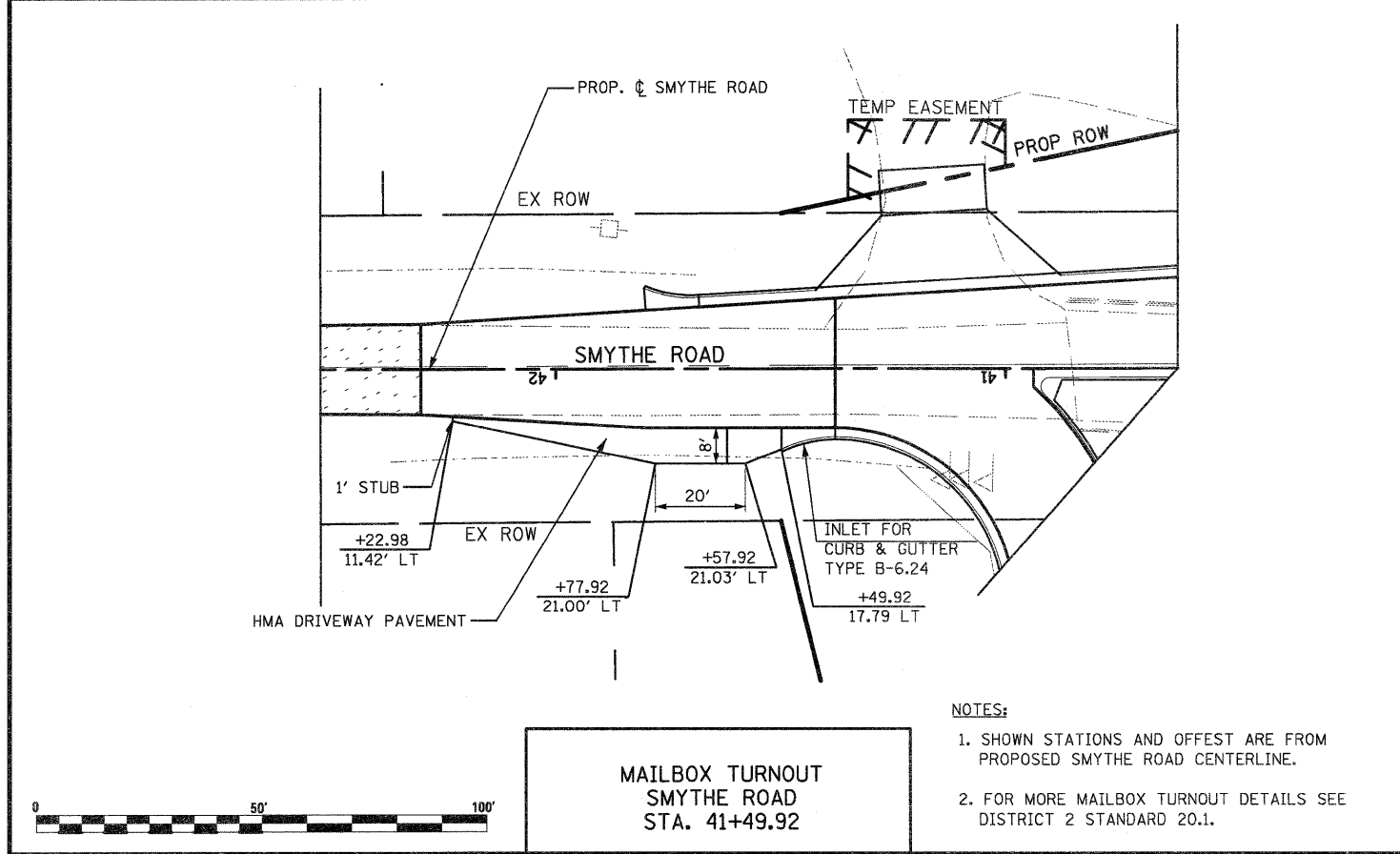
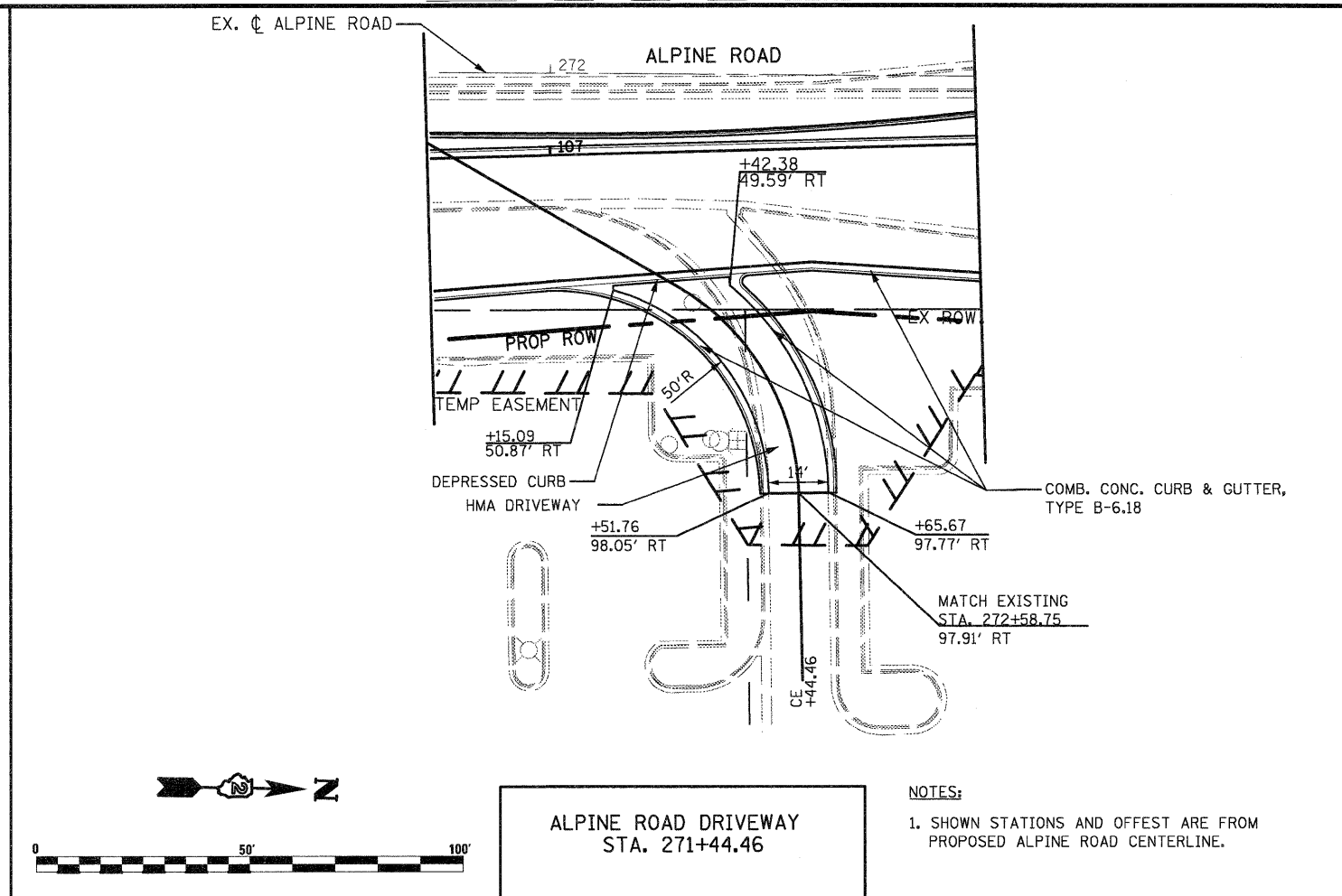
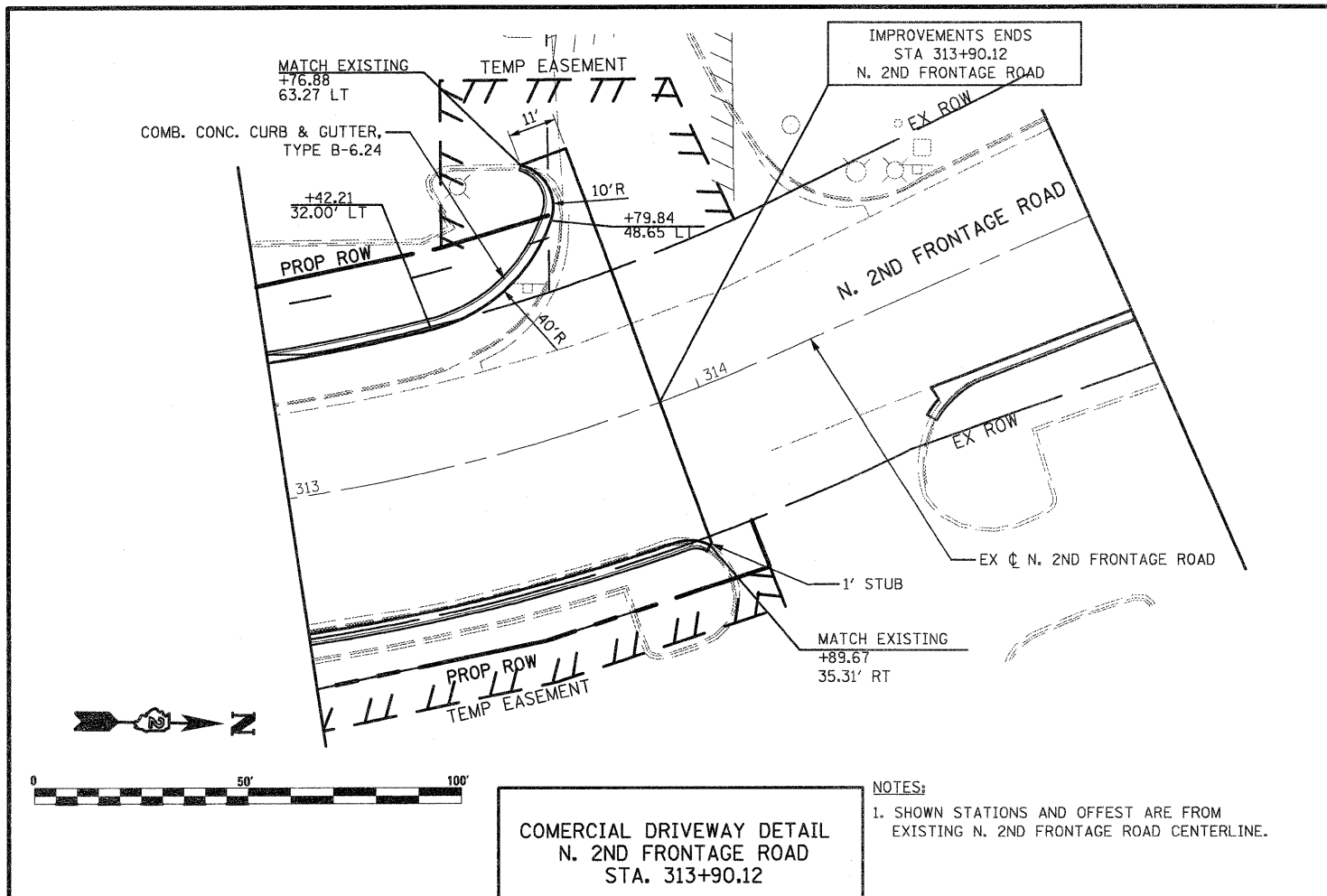

FILE NAME = D264987-sht-details-02.dgn

USER NAME = 3202040971

PLOT SCALE = 40.0000' / IN.

PLOT DATE = 1/18/2011

DESIGNED - LOM

DRAWN - MD

CHECKED - PDK

DATE - 01-19-2011

REVISED -

REVISED -

REVISED -

REVISED -

STATE OF ILLINOIS
DEPARTMENT OF TRANSPORTATION

ROADWAY DETAILS

SCALE: SHEET NO. OF SHEETS STA. TO STA.

F.A.P. RTE.	SECTION	COUNTY	TOTAL SHEETS	SHEET NO.
303	129K-1	WINNEBAGO	401	74
CONTRACT NO. 64987				

FED. ROAD DIST. NO. 2 ILLINOIS FED. AID PROJECT

NOTE:

1. EXISTING UTILITIES TO BE RELOCATED PRIOR TO GRADING.

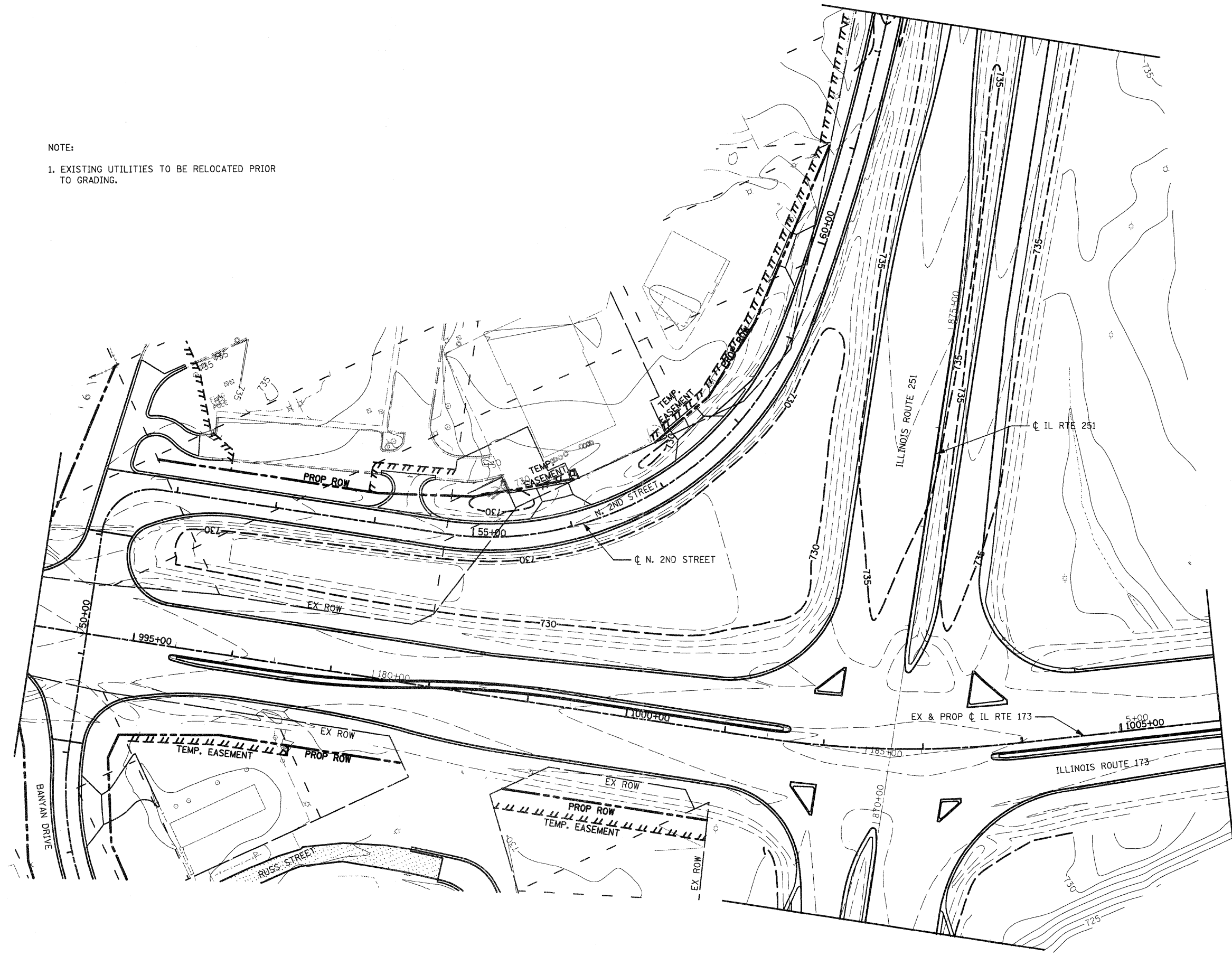
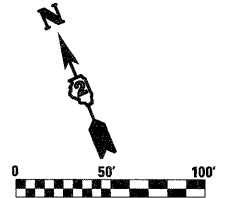

FILE NAME =
0264987-ah-grad-01.dgn

USER NAME = 3202090971
PLOT SCALE = 100.0000' / IN.
PLOT DATE = 1/18/2011

DESIGNED - LOM
DRAWN - MD
CHECKED - PDK
DATE - 01-19-2011

REVISED -
REVISED -
REVISED -
REVISED -

STATE OF ILLINOIS
DEPARTMENT OF TRANSPORTATION

GRADING PLAN
RALSTON ROAD \ IL ROUTE 173 AT IL ROUTE 251

SCALE: SHEET NO. OF SHEETS STA. TO STA.

F.A.P. RTE.	SECTION	COUNTY	TOTAL SHEETS	SHEET NO.
303	129K-1	WINNEBAGO	401	75
CONTRACT NO. 64987			FED. ROAD DIST. NO. 2 ILLINOIS FED. AID PROJECT	

STAGING GENERAL NOTES:

1. POSITIVE DRAINAGE SHALL BE MAINTAINED AT ALL TIMES,
2. USE AGGREGATE FOR TEMPORARY ACCESS OR INCIDENTAL BITUMINOUS SURFACING AND SIGNING AT DRIVEWAYS AND SIDE STREETS AS REQUIRED TO MAINTAIN ACCESS AND AT THE DIRECTION OF THE ENGINEER.
3. CONTRACTOR TO COORDINATE MAILBOX RELOCATION WITH POSTAL AUTHORITIES TO PROVIDE CONTINUED SERVICE THROUGHOUT CONSTRUCTION.
4. A MINIMUM OF ONE LANE OF TRAFFIC SHALL BE MAINTAINED IN EACH DIRECTION AT ALL TIMES. EXCEPT FOR IL 251 WHERE TWO THROUGH LANES OF TRAFFIC SHALL BE MAINTAINED AT ALL TIMES. LANES SHALL BE 10 FT MINIMUM WIDTH.
5. TEMPORARY PAVEMENT MARKINGS SHALL BE PAINT. SEE THE SPECIAL PROVISIONS FOR PAINT REMOVAL ON PROPOSED PAVEMENT.
6. THE CONTRACTOR WILL NOT BE ALLOWED TO SET UP A YARD OR FIELD OFFICE ON STATE PROPERTY WITHOUT WRITTEN CONSENT FROM THE DEPARTMENT.
7. CONSTRUCTION ACTIVITIES ON BOTH SIDES OF TRAFFIC SHALL NOT BE PERMITTED AT THE SAME TIME. THE CONTRACTOR WILL BE RESPONSIBLE TO ORGANIZE SEQUENCE OF WORK TO AVOID IT.
8. ACCESS TO DRIVEWAYS AND SIDE ROADS SHALL BE MAINTAINED AT ALL TIMES, UNLESS OTHERWISE NOTED ON THE PLANS.

CONSTRUCTION SEASON 2011

PRE-STAGE GENERAL CONSTRUCTION:

- REMOVE ISLANDS, MEDIANS, CURB AND GUTTER, AND REPLACE WITH TEMPORARY PAVEMENT AS INDICATED ON WINTER SHUT DOWN AND STAGE 1 PLANS.
- PLACE TEMPORARY PAVEMENT ALONG IL 251 AND OTHER CROSS STREETS AS SHOWN ON WINTER SHUT DOWN PLANS.
- REMOVE TRAFFIC SIGNALS AT IL 173 INTERSECTIONS WITH ORLANDO STREET AND WITH CONTINENTAL DRIVE AND INSTALL TEMPORARY TRAFFIC SIGNALS.
- CONSTRUCT TEMPORARY INTERSECTION AND LEFT TURN LANE FROM SB IL 251 AT MELBOURNE AVENUE, REMOVE ISLAND, PLACE TEMPORARY PAVEMENT AND INSTALL TEMPORARY TRAFFIC SIGNALS.
- CONSTRUCT MEDIAN CROSSOVER WITH TEMPORARY PAVEMENT PER STANDARD 91.1 AT NORTH AND SOUTH IL 251 SECTION LIMITS AS SHOWN ON WINTER SHUT DOWN PLANS.

NOTE: REMOVAL OF EXISTING ISLANDS, MEDIANS AND CURB AND GUTTER AND REPLACEMENT WITH TEMPORARY PAVEMENT SHALL BE PERFORMED USING DAILY CLOSURES IN ACCORDANCE WITH IDOT STANDARDS. AFTER TEMPORARY PAVEMENT IS INSTALLED EXISTING PAVEMENT MARKINGS EDGE LINES AND MEDIANS SHALL BE STRIPED WITH PAINT PAVEMENT MARKINGS. ALL GROUND SURFACES DISTURBED DURING CONSTRUCTION SHALL BE SEEDED AND OTHER EROSION CONTROL MEASURES SHALL BE IN PLACE FOR THE WINTER SHUTDOWN. ALL UTILITY ADJUSTMENTS AND RELOCATIONS SHALL BE COMPLETED BY THE END OF THE PRE-STAGE.

PRE-STAGE 1 CONSTRUCTION:

- THE EXISTING CULVERT UNDER IL 173 WILL REQUIRE A TEMPORARY EXTENSION TO THE NORTH TO ALLOW FOR THE REQUIRED TEMPORARY PAVEMENT FOR PRE-STAGE 1 CONFIGURATION.
- CONSTRUCT SOUTH PORTION OF NEW CULVERT UNDER IL 173 DURING THIS PRE-STAGE. EXISTING GUARDRAIL AT THE LOCATION SHALL BE REMOVED AND REINSTALLED AT THE END OF THE PRE-STAGE.
- INSTALL TEMPORARY PAVEMENT AT THE LOCATIONS SHOWN ON THE PRE-STAGE 2 PLANS.
- CONSTRUCT TEMPORARY DRAINAGE APPURTENANCES AS REQUIRED FOR TEMPORARY PAVEMENT CONSTRUCTION.
- REMOVE SOUTHEAST, NORTHEAST AND NORTHWEST ISLANDS AT THE IL 173/ORLANDO INTERSECTION AND CONSTRUCT TEMPORARY PAVEMENT.
- INSTALL TEMPORARY TRAFFIC SIGNALS AT ORLANDO INTERSECTION FOR USE WITH PRESTAGE 2 TRAFFIC CONFIGURATION.
- REMOVE EXISTING TRAFFIC SIGNALS AT THE IL 173/CONTINENTAL DRIVE INTERSECTION, ERECT TEMPORARY TRAFFIC SIGNALS AND CONSTRUCT PROPOSED TEMPORARY PAVEMENT.

PRE-STAGE 1 TRAFFIC:

- ONE THROUGH LANE IN EACH DIRECTION AND ALL LEFT TURN LANES SHALL BE MAINTAINED ALONG IL 173 DURING PRE-STAGE 1.
- TRAFFIC ALONG IL 173 BETWEEN IL 251 AND ALPINE ROAD WILL BE SHIFTED TO EXISTING WB PAVEMENT AND PREVIOUSLY PLACED TEMPORARY PAVEMENT.

PRE-STAGE 2 CONSTRUCTION:

- CONSTRUCT NORTH PORTION OF IL 173 CULVERT.
- CONSTRUCT CULVERT UNDER N 2ND FRONTAGE ROAD.
- CONSTRUCT CHANNEL WALLS BETWEEN CULVERTS, AND PROPOSED STORM SEWERS IN PROXIMITY TO THE WALLS.
- DURING PRE-STAGE 2 THE CHANNEL FLOW WILL BE DIVERTED IN TO AN EXISTING PIT LOCATED BEHIND COMMERCIAL DEVELOPMENT (*HOME DEPOT*). CHANNEL RELOCATION AND CHANNEL WALL CONSTRUCTION SHOULD START IN THIS PRE-STAGE.
- ONCE THE PROPOSED CULVERT UNDER IL 173 IS COMPLETE AND THE CHANNEL IS FLOWING THROUGH THE PROPOSED CULVERT REMOVE THE NORTH PORTION OF THE EXISTING CULVERT INCLUDING THE TEMPORARY EXTENSION.
- INSTALL TEMPORARY PAVEMENT AT THE LOCATIONS SHOWN ON THE PRE-STAGE 3 PLANS. CONSTRUCT TEMPORARY DRAINAGE APPURTENANCES AS REQUIRED FOR TEMPORARY PAVEMENT CONSTRUCTION.

PRE-STAGE 2 TRAFFIC:

- ONE THROUGH LANE IN EACH DIRECTION ALONG IL 173 AND ALL LEFT TURN LANES, EXCEPT EB LEFT TURN LANE AT IL 173/ N 2ND FRONTAGE ROAD, SHALL BE MAINTAINED DURING CULVERT CONSTRUCTION.
- TRAFFIC ALONG IL 173 BETWEEN IL 251 AND ALPINE ROAD WILL BE SHIFTED TO EXISTING EB PAVEMENT AND PREVIOUSLY PLACED TEMPORARY PAVEMENT.
- N. 2ND FRONTAGE ROAD BETWEEN IL 173 AND KOHL'S ENTRANCE WILL BE CLOSED TO TRAFFIC DURING THIS STAGE FOR A MAXIMUM OF TWO WEEKS. ACCESS TO KOHL'S SHALL BE PROVIDED UTILIZING NB ALPINE ROAD, WB GATEWAY COURT AND SB N. 2ND FRONTAGE ROAD TO THE KOHL'S ENTRANCE.

PRE-STAGE 3 CONSTRUCTION:

- REMOVE THE SOUTH PORTION OF THE EXISTING CULVERT UNDER IL 173.
- COMPLETE ALL OTHER PRE-STAGE GENERAL CONSTRUCTION ITEMS: TEMPORARY PAVEMENT, TEMPORARY DRAINAGE, TEMPORARY TRAFFIC SIGNALS, ETC.
- PROVIDE STRIPING FOR WINTER SHUTDOWN TRAFFIC CONFIGURATION.
- REMOVE ISLANDS AND MEDIANS AND PLACE TEMPORARY PAVEMENT.

PRE-STAGE 3 TRAFFIC:

- ONE THROUGH LANE IN EACH DIRECTION AND ALL LEFT TURN LANES SHALL BE MAINTAINED ALONG IL 173 DURING PRE-STAGE 3. TRAFFIC WILL BE SHIFTED TO EXISTING WB PAVEMENT AND PREVIOUSLY PLACED TEMPORARY PAVEMENT.

NOTE: ALL CONSTRUCTION ACTIVITIES SHALL CEASE AND ALL EXISTING TRAFFIC PATTERNS REESTABLISHED BY NOVEMBER 1, 2011 (REFER TO WINTER SHUT DOWN PLAN SHEETS). THE TEMPORARY LEFT TURN LANE FROM SB IL 251 TO MELBOURNE AVENUE SHALL BE CLOSED DURING THE WINTER SHUT DOWN.

CONSTRUCTION SEASON 2012

STAGE 1 GENERAL CONSTRUCTION:

- INSTALL TEMPORARY ROADWAY LIGHTING AT IL 251 MEDIAN CROSSOVERS LOCATED NORTH AND SOUTH OF IL 173 BEFORE START OF STAGE 1A. LOCATIONS SHALL BE AS DIRECTED BY THE ENGINEER.
- CONSTRUCT EAST EXTENSION FOR CULVERT UNDER IL 251.
- REMOVE REMAINING EXISTING ISLANDS AND CONSTRUCT TEMPORARY PAVEMENT AS SHOWN ON STAGE 2 PLANS.
- INSTALL REMAINING TEMPORARY TRAFFIC SIGNALS.
- CONSTRUCT THE NORTH SIDE OF IL 173.
- CONSTRUCT THE NEW WESTERN PORTION OF N. 2ND STREET AS INDICATED ON THE PLANS.
- CONSTRUCT THE EAST SIDE OF ORLANDO STREET AND ALPINE ROAD.
- THE PROPOSED CENTER MEDIANS AND ISLANDS ON IL 173 WILL NOT BE CONSTRUCTED BUT WILL HAVE TEMPORARY PAVEMENT INSTALLED INSTEAD AS INDICATED ON THE PLANS.
- FINALIZE CHANNEL AND RELATED RETAINING WALLS CONSTRUCTION, BETWEEN N. 2ND FRONTAGE ROAD AND ALPINE ROAD.
- CONSTRUCT EASTSIDE AND INTERSECTION OF N. 2ND FRONTAGE ROAD.
- CONSTRUCT ASSOCIATED PROPOSED STORM SEWERS AND ADJUST EXISTING DRAINAGE ITEMS.

STAGE 1A CONSTRUCTION:

- CONSTRUCT PROPOSED CULVERT EXTENSION AT IL 251 SOUTH OF IL 173, AND COMPLETE THIS PORTION OF TEMPORARY PAVEMENT.
- ISLAND REMOVAL AND TEMPORARY PAVING AT REMAINING INTERSECTIONS.
- TEMPORARY TRAFFIC SIGNAL INSTALLATION AT REMAINING INTERSECTIONS.
- RELOCATE TRAFFIC SIGNAL AT ALPINE ROAD/ROSE RD INTERSECTION.
- CONSTRUCT THE NE QUADRANT OF THE IL 173/IL 251.
- CONSTRUCT THE NE QUADRANT OF IL 173 AT ALPINE ROAD.
- CONSTRUCT EAST HALF OF N. 2ND FRONTAGE ROAD.
- CONSTRUCT EAST HALF OF ALPINE ROAD EXCLUDING MEDIAN, PLACE TEMPORARY PAVEMENT INSTEAD.

STAGE 1A TRAFFIC:

- ONE THROUGH LANE IN EACH DIRECTION AND ALL LEFT TURN LANES WILL BE MAINTAINED ON IL 173 ON THE EXISTING SOUTH SIDE PAVEMENT AND TEMPORARY PAVEMENT.
- EXISTING NORTH 2ND STREET WILL REMAIN FULLY OPEN DURING THIS STAGE. BANK ACCESS WILL BE MAINTAINED THROUGH THE ROAD RANGER PARKING LOT.
- TWO THROUGH LANES IN EACH DIRECTION AND LEFT TURN LANES WILL BE MAINTAINED ON THE EXISTING IL 251 PAVEMENT AND TEMPORARY PAVEMENT UTILIZING A CROSS-OVER.
- ONE THROUGH LANE IN EACH DIRECTION WILL BE MAINTAINED ON THE EXISTING PAVEMENT OF ORLANDO STREET. THERE WILL NOT BE TURN LANES PROVIDED FOR THIS STAGE ON ORLANDO STREET.
- ONE THROUGH LANE IN EACH DIRECTION AND LEFT TURN LANES WILL BE MAINTAINED ON THE EXISTING PAVEMENT OF ALPINE ROAD.
- TEMPORARY INTERSECTION, IL 251 AT MELBOURNE AVENUE, SHALL BE OPEN FOR TRAFFIC.

STAGE 1B CONSTRUCTION:

- BEGIN CONSTRUCTING THE NW QUADRANT OF IL 173 AT IL 251.
- CONSTRUCT THE WEST HALF OF THE INTERSECTION OF N. 2ND FRONTAGE ROAD AND IL 173 USING HIGH-EARLY STRENGTH PCC PAVEMENT.

STAGE 1B TRAFFIC:

- ONE THROUGH LANE IN EACH DIRECTION AND ALL LEFT TURN LANES WILL BE MAINTAINED ON IL 173 ON THE EXISTING SOUTH SIDE PAVEMENT AND TEMPORARY PAVEMENT.
- EXISTING NORTH 2ND STREET WILL REMAIN FULLY OPEN DURING THIS STAGE.
- TWO THROUGH LANES IN EACH DIRECTION AND LEFT TURN LANES WILL BE MAINTAINED ON THE EXISTING IL 251 PAVEMENT AND TEMPORARY PAVEMENT UTILIZING A CROSS-OVER.
- ONE THROUGH LANE IN EACH DIRECTION WILL BE MAINTAINED ON THE EXISTING PAVEMENT OF ORLANDO STREET. THERE WILL NOT BE TURN LANES PROVIDED FOR THIS STAGE ON ORLANDO STREET.
- N. 2ND FRONTAGE ROAD WILL BE CLOSED FOR A MAXIMUM OF TWO WEEKS TO ALLOW FOR THIS CONSTRUCTION.
- ONE THROUGH LANE IN EACH DIRECTION AND LEFT TURN LANES WILL BE MAINTAINED ON THE EXISTING PAVEMENT OF ALPINE ROAD.

STAGE 1C CONSTRUCTION:

- COMPLETE CONSTRUCTION OF THE NW QUADRANT OF IL 251.
- CONSTRUCT THE NW QUADRANT OF THE INTERSECTION OF IL 173 AT ALPINE ROAD USING HIGH-EARLY STRENGTH PCC PAVEMENT.
- COMPLETE ALL STAGE 1 GENERAL CONSTRUCTION: NORTH SIDE OF IL 173, DRAINAGE APPURTENANCES, CHANNEL WALLS, WEST HALF INTERSECTION OF N. 2ND FRONTAGE ROAD AND ALPINE ROAD. EAST SIDE PAVEMENT ALONG ORLANDO STREET. ALL TEMPORARY PAVEMENT SHALL BE PLACED FOR USE DURING STAGE 2.

STAGE 1C TRAFFIC:

- ONE THROUGH LANE IN EACH DIRECTION AND ALL LEFT TURN LANES WILL BE MAINTAINED ON IL 173 ON THE EXISTING SOUTH SIDE PAVEMENT AND TEMPORARY PAVEMENT.
- EXISTING NORTH 2ND STREET WILL REMAIN FULLY OPEN DURING THIS STAGE.
- TWO THROUGH LANES IN EACH DIRECTION AND LEFT TURN LANES WILL BE MAINTAINED ON THE EXISTING IL 251 PAVEMENT AND TEMPORARY PAVEMENT UTILIZING A CROSS-OVER.
- ONE THROUGH LANE IN EACH DIRECTION WILL BE MAINTAINED ON THE EXISTING PAVEMENT OF ORLANDO STREET. THERE WILL NOT BE TURN LANES PROVIDED FOR THIS STAGE ON ORLANDO STREET.
- ONE THROUGH LANE IN EACH DIRECTION AND LEFT TURN LANES WILL BE MAINTAINED ON THE EXISTING PAVEMENT OF SOUTH ALPINE ROAD.
- ALPINE ROAD NORTH OF IL 173 WILL BE CLOSED FOR A MAXIMUM OF TWO WEEKS TO ALLOW FOR CONSTRUCTION OF THE WEST HALF OF THE INTERSECTION OF ALPINE ROAD NORTH OF IL 173.

STAGE 2A CONSTRUCTION:

- CONSTRUCT THE SOUTH SIDE OF IL 173.
- CONSTRUCTION ALONG N. 2ND STREET WILL CONSIST OF THE REPLACEMENT/REALIGNMENT OF THE EXISTING WEST PORTION.
- RECONSTRUCTION OF THE SMYTHE AVENUE INTERSECTION AND BANYAN DRIVE CONSTRUCTION SHALL BE STAGGERED DURING THIS STAGE IN ORDER TO MAINTAIN CONSTANT ACCESS TO THE FRONTAGE ROAD SOUTH OF IL 173.
- CONSTRUCT THE SW QUADRANT OF IL 173 AT IL 251.
- CONSTRUCT THE WEST SIDE OF ORLANDO STREET, ALPINE ROAD AND N. 2ND FRONTAGE ROAD.
- ALL RELATED STORM SEWER CONSTRUCTION AND OTHER NECESSARY WORK SHALL BE DONE IN THIS STAGE.
- INSTALL TEMPORARY PAVEMENT REQUIRED FOR STAGE 2B TRAFFIC LANES.

STAGE 2A TRAFFIC:

- ONE THROUGH LANE IN EACH DIRECTION AND ALL LEFT TURN LANES WILL BE MAINTAINED ON THE NEW PAVEMENT OF IL 173 AND TEMPORARY PAVEMENT.
- THE NEW WEST PORTION OF N. 2ND STREET WILL BE OPEN BY THE END OF THIS STAGE AS WELL AS THE EXISTING EAST PORTION. ALL BUSINESS ACCESS WILL BE MAINTAINED THROUGH PARKING LOT CONNECTION.
- TWO THROUGH LANES IN EACH DIRECTION AND LEFT TURN LANES WILL BE MAINTAINED ON IL 251.
- ONE THROUGH LANE IN EACH DIRECTION WILL BE MAINTAINED ON ORLANDO STREET. TURN LANES WILL NOT BE PROVIDED ALONG ORLANDO STREET DURING THIS STAGE.
- ONE THROUGH LANE IN EACH DIRECTION AND LEFT TURN LANES WILL BE MAINTAINED ON ALPINE ROAD.

FILE NAME = D264987-sh-t-staging-001.dgn	USER NAME = 322209971	DESIGNED - LOM	REVISED -	STATE OF ILLINOIS DEPARTMENT OF TRANSPORTATION		STAGING AND TRAFFIC CONTROL NOTES				F.A.P RTE.	SECTION	COUNTY	TOTAL SHEETS	SHEET NO.	
		DRAWN - MD	REVISED -							303	129K-1	WINNEBAGO	401	76	
	PLOT SCALE = 100.0000' / IN.	CHECKED - PDK	REVISED -							CONTRACT NO. 64987					
	PLOT DATE = 1/18/2011	DATE - 01-19-2011	REVISED -			SCALE:	SHEET NO.	OF	SHEETS	STA.	TO	STA.	FED. ROAD DIST. NO. 2 ILLINOIS FED. AID PROJECT		

STAGE 2B THROUGH 3 CONSTRUCTION:

- CONSTRUCT THE INTERSECTIONS AND REMAINING SECTIONS OF THE SIDE ROADS WITH MULTIPLE STAGES AND SUB STAGES AS SHOWN ON THE PLAN SHEETS.
- REMOVE TEMPORARY PAVEMENT FROM IL ROUTE 251, MEDIAN AREA (NORTH CROSSOVER) (DURING STAGE 2C).

STAGE 2B THROUGH 3 TRAFFIC:

- ONE THROUGH LANE IN EACH DIRECTION AND SINGLE LEFT TURN LANES WILL BE MAINTAINED ON THE NEW PAVEMENT OF IL 173 AND TEMPORARY PAVEMENT.
- NORTH 2ND STREET WILL BE FULLY OPEN TO TRAFFIC AFTER STAGE 2B.
- ONE THROUGH LANE IN EACH DIRECTION AND LEFT TURN LANES WILL BE MAINTAINED ON THE NEW PAVEMENT OF IL 251.
- ONE THROUGH LANE IN EACH DIRECTION WILL BE MAINTAINED ON ORLANDO STREET. THERE WILL NOT BE TURN LANES PROVIDED FOR THESE STAGES ON ORLANDO STREET.
- ONE THROUGH LANE IN EACH DIRECTION AND LEFT TURN LANES WILL BE MAINTAINED ON ALPINE ROAD.

STAGE 4A AND 4B CONSTRUCTION:

- REMOVE TEMPORARY PAVEMENT FROM IL ROUTE 251, MEDIAN AREA (SOUTH CROSSOVER) (DURING STAGE 4A).
- COMPLETE TAPERS ALONG IL 173 BETWEEN ORLANDO STREET AND ALPINE ROAD
- COMPLETE TAPERS ALONG ORLANDO STREET SOUTH OF IL 173.
- COMPLETE TAPERS ALONG ALPINE ROAD; NORTH ALPINE ROAD MILLING AND RESURFACING SHALL BE PERFORMED UNDER TRAFFIC USING SHORT TERM CLOSURES.
- REMOVE TEMPORARY PAVEMENT AND FINISH CONSTRUCTION OF THE CENTER MEDIANS ON IL 173.
- REMOVE TEMPORARY PAVEMENT FROM TRAFFIC SIGNAL ISLANDS AND INSTALL THE CONCRETE ISLANDS.
- INSTALL PERMANENT TRAFFIC SIGNALS AT INTERSECTIONS AS INDICATED ON THE PLANS.
- REMOVE SB IL 251 LEFT TURN LANE AT MELBOURNE AVENUE AND RECONSTRUCT ISLAND.
- ALL LANDSCAPING AND MISCELLANEOUS WORK SHALL BE PERFORMED.
- TEMPORARY PAVEMENT MARKING SHALL BE REMOVED FROM THE NEW PAVEMENT AND PERMANENT PAVEMENT MARKING SHALL BE INSTALLED PER PLAN.

STAGE 4A AND 4B TRAFFIC:

- ONE LANE OF THROUGH TRAFFIC AND SINGLE LEFT TURN LANES WILL BE MAINTAINED ON IL 173 ON THE NEW PAVEMENT IN BOTH DIRECTIONS.
- N 2ND STREET WILL BE FULLY OPEN DURING THIS STAGE.
- IL 251 WILL BE FULLY OPEN EXCEPT FOR LIMITED TURN LANES.
- ONE THROUGH LANE IN EACH DIRECTION WILL BE MAINTAINED WITH A LEFT TURN LANE ON ORLANDO STREET.
- ALPINE ROAD WILL BE FULLY OPEN EXCEPT FOR LIMITED TURN LANES.

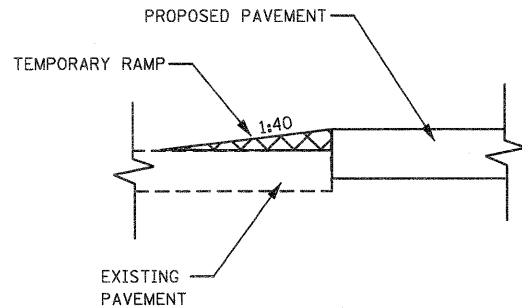

TEMPORARY RAMP DETAIL

2" HOT-MIX ASPHALT, SURFACE COURSE MIX "C", N50
5" HOT-MIX ASPHALT BINDER COURSE IL-19.0, N50
12" SUB-BASE GRANULAR MATERIAL, TYPE A

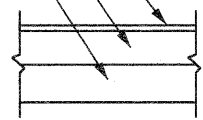

TEMPORARY PAVEMENT DETAIL

 W20-1(O)-48 ①	 G20-5aP(O) ②	 R2-1 ③	 W2-1I13(O) ④	 R2-1I06 ⑤	 W16-5P(L)(O) ⑥	 W16-5P(R)(O) ⑦	 W1-4(L)(O)-48 ⑧	 W1-4(R)(O)-48 ⑨	NOT USED ⑩
 R2-12 ⑪	 W6-3(O)-48 ⑫	 R3-1I00(R) ⑬	 W16-7P(R) ⑭	 W20-5R(O)-48 ⑮	 W24-1(O)-48 ⑯	 W1-7(O) ⑰	 W20-5(L)-48 ⑱	 W24-1a(L)(O)-48 ⑲	 R3-1I00(L) ⑳
 W16-7P(L) ㉑	 R11-2 ㉒	 R3-1 ㉓	 W20-2(O)-48 ㉔	 W17-1I01(O) ㉕	 M4-9R(O) ㉖	 M4-9L(O) ㉗	 W1-46(R)(O)-48 ㉘	 W1-46(L)(O)-48 ㉙	 W17-1I00(O) ㉚
 W4-1(O) ㉛	 R1-2 ㉜	 M3-3(O) ㉝	 W20-1I03(O)-48 ㉞	 W20-1I03(O)-48 ㉟	 R2-1I06 ㊱	 W3-3(O) ㊲	 XXXXX-48 ㊳	 R1-1 ㊴	 R3-2 ㊵
 W16-1I01(O)-48 ㊶	 W16-1I01(O)-48 ㊷	 W1-6(O) ㊸	 R11-3(O) ㊹	 R10-11a ㊺	 W20-3(O)-48 ㊻	 W20-3(O)-48 ㊼	 W21-1I00(O)48 ㊽	NOT USED ㊾	 W24-1(O)L-48 ㊿
 W1-4L(O)-48 ①	 R3-7 ②	 R11-4 ③	 W1-4R(O)-48 ④	 ⑤	 ⑥				

FILE NAME =
D264987-shtr-staging-002.dgn

USER NAME = 320207071

DESIGNED - LOM

REVISED -

DRAWN - MD

REVISED -

PLOT SCALE = 100.0000' / IN.

CHECKED - PDK

REVISED -

PLOT DATE = 1/18/2011

DATE - 01-19-2011

REVISED -

STATE OF ILLINOIS
DEPARTMENT OF TRANSPORTATION







STAGING AND TRAFFIC CONTROL NOTES

SCALE: SHEET NO. OF SHEETS STA. TO STA.

F.A.P. RTE.	SECTION	COUNTY	TOTAL SHEETS	SHEET NO.
303	129K-1	WINNEBAGO	401	77
CONTRACT NO. 64987				

FED. ROAD DIST. NO. 2 ILLINOIS FED. AID PROJECT

LEGEND

-  PAVEMENT CONSTRUCTION
-  TEMPORARY PAVEMENT
-  NEWLY CONSTRUCTED PAVEMENT (PREVIOUS STAGES)
-  TYPE II BARRICADE OR DRUM
-  DIRECTION OF TRAFFIC
-  VERTICAL PANEL
-  TEMPORARY CONCRETE BARRIER

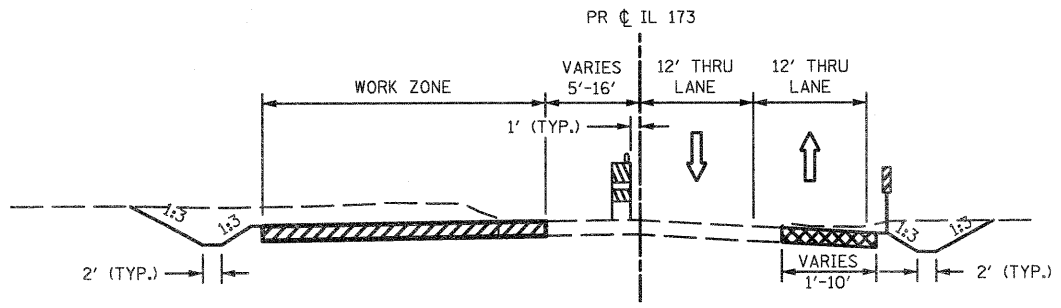

IL 173 TYPICAL SECTION
STA 986+57.79 - 995+72.52

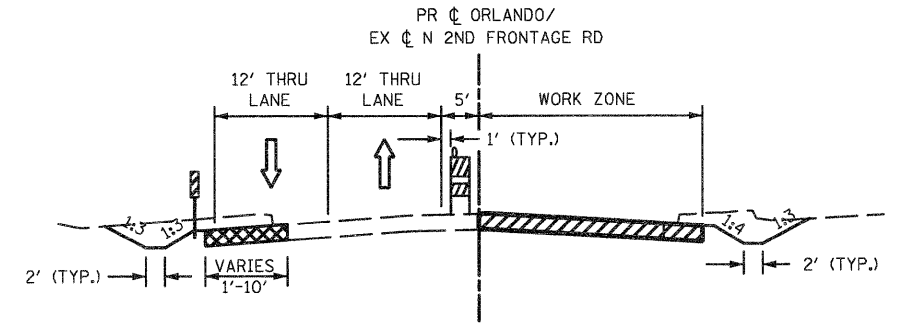

ORLANDO ST / N 2D FRONTAGE RD
TYPICAL SECTION
STA 77+32.96 - STA 313+68.05

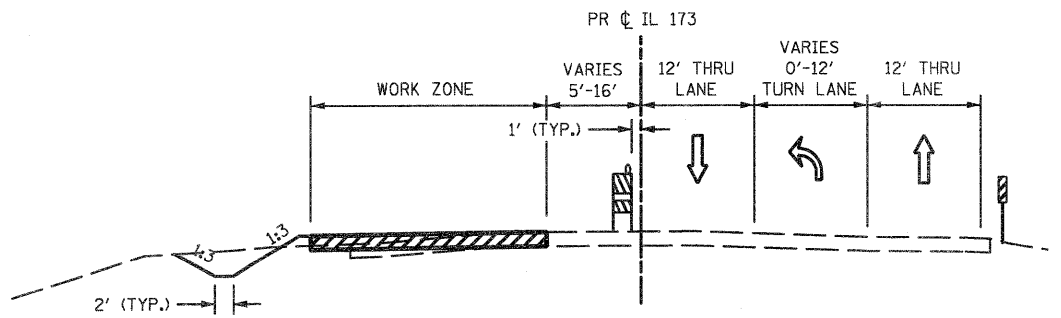

IL 173 TYPICAL SECTION
STA 995+72.52 - 999+57.48

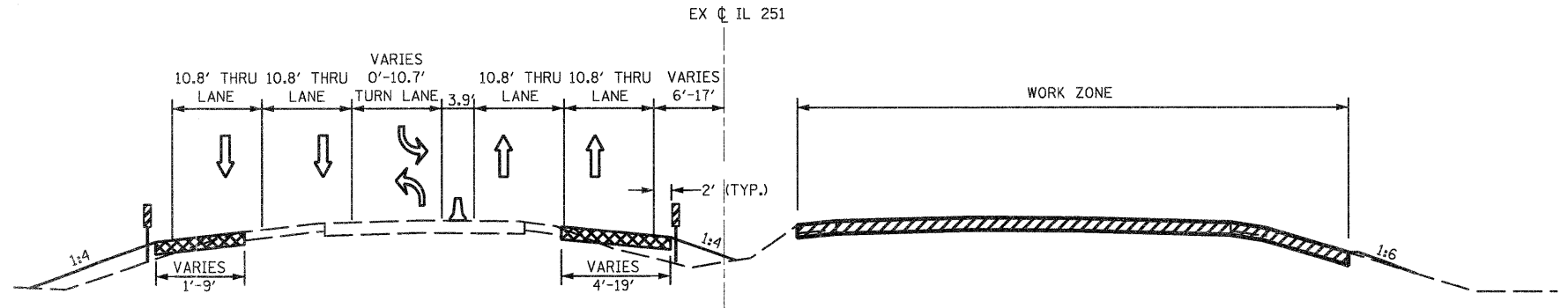

IL 251 TYPICAL SECTION
STA 862+68.96 - STA 878+83.13

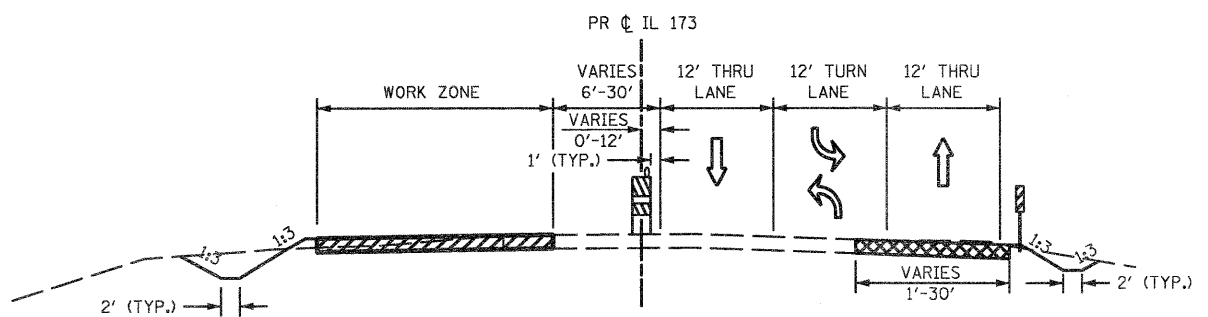

IL 173 TYPICAL SECTION
STA 999+57.48 - 1028+02.08
NOTE: CONCRETE BARRIER TO BE INSTALLED IN LIEU OF TYPE II BARRICADES BETWEEN STA 1018+10.66 AND 1024+59.00

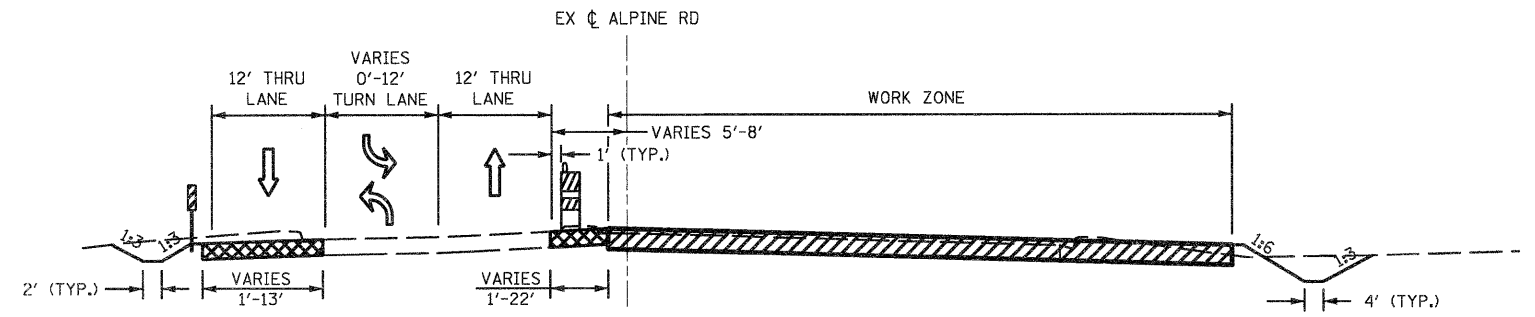

ALPINE RD TYPICAL SECTION
STA 266+41.73 - 275+00.00
NOTE: CONCRETE BARRIER TO BE INSTALLED IN LIEU OF TYPE II BARRICADES BETWEEN STA 269+00.00 AND 272+00.00

FILE NAME =
0264987-shr-staging-003.dgn

USER NAME = 3222090971
PLOT SCALE = 20.0000' / IN.
PLOT DATE = 1/19/2011

DESIGNED - LOM
DRAWN - MD
CHECKED - PDK
DATE - 01-19-2011

REVISED -
REVISED -
REVISED -
REVISED -







STATE OF ILLINOIS
DEPARTMENT OF TRANSPORTATION

STAGING AND TRAFFIC CONTROL
TYPICAL SECTIONS
STAGE 1A, 1B, 1C

SCALE: N/A SHEET NO. OF SHEETS STA. TO STA.

F.A.P. RTE.	SECTION	COUNTY	TOTAL SHEETS	SHEET NO.
303	129K-1	WINNEBAGO	401	78
CONTRACT NO. 64987				
FED. ROAD DIST. NO. 2 ILLINOIS FED. AID PROJECT				

LEGEND

-  PAVEMENT CONSTRUCTION
-  TEMPORARY PAVEMENT
-  NEWLY CONSTRUCTED PAVEMENT (PREVIOUS STAGES)
-  TYPE II BARRICADE OR DRUM
-  DIRECTION OF TRAFFIC
-  VERTICAL PANEL
-  TEMPORARY CONCRETE BARRIER

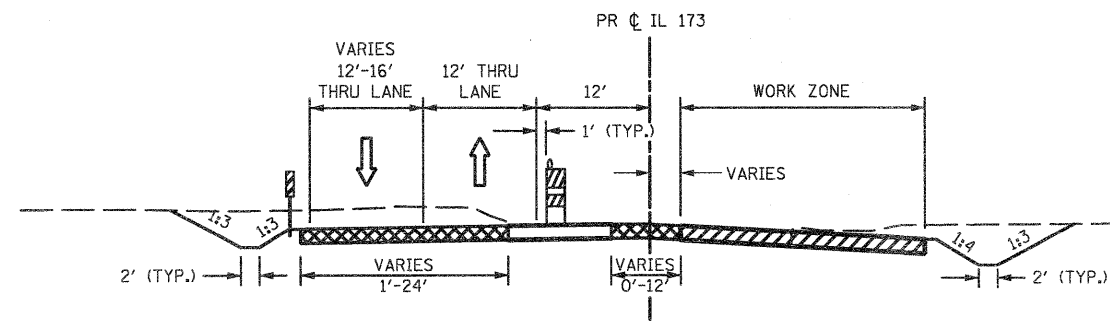

IL 173 TYPICAL SECTION
STA 986+56.97 - 995+52.54

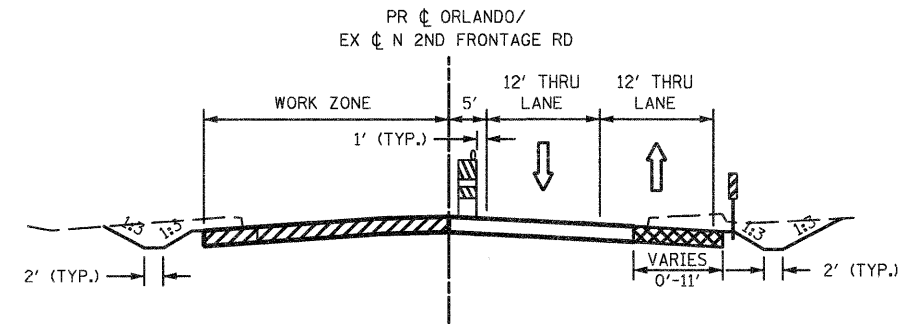

ORLANDO ST / N 2D FRONTAGE RD
TYPICAL SECTION
STA 77+25.00 - STA 314+57.89

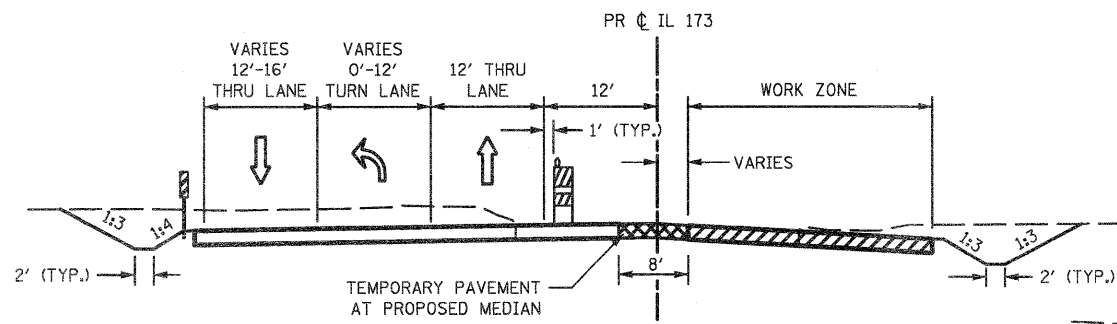

IL 173 TYPICAL SECTION
STA 995+52.54 - 999+92.52

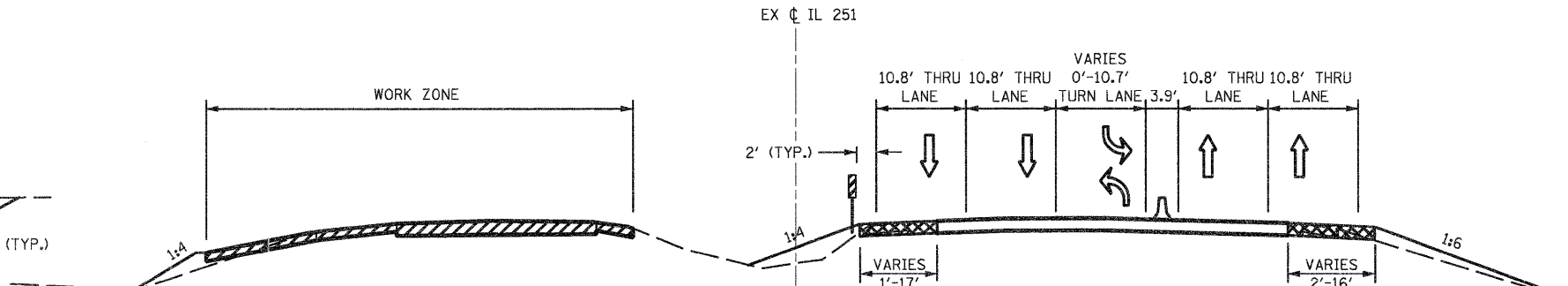

IL 251 TYPICAL SECTION
STA 862+68.95 - STA 878+83.13

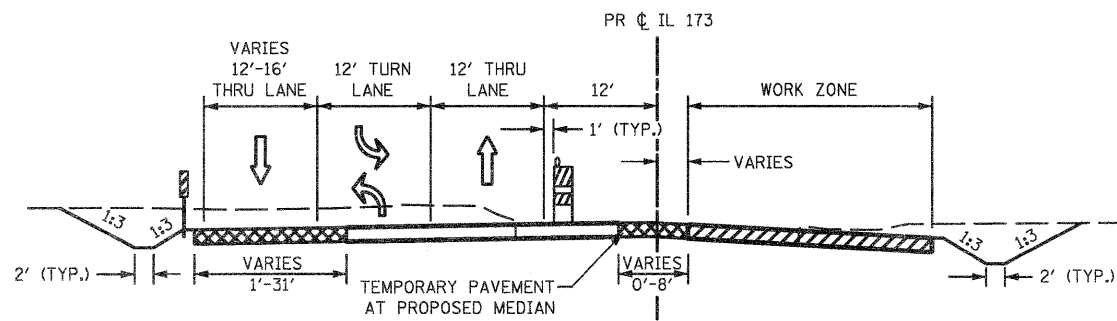

IL 173 TYPICAL SECTION
STA 999+92.52 - 1029+70.53

NOTE: CONCRETE BARRIER TO BE INSTALLED IN LIEU OF TYPE II BARRICADES BETWEEN STA 1018+32.81 AND 1024+60.60

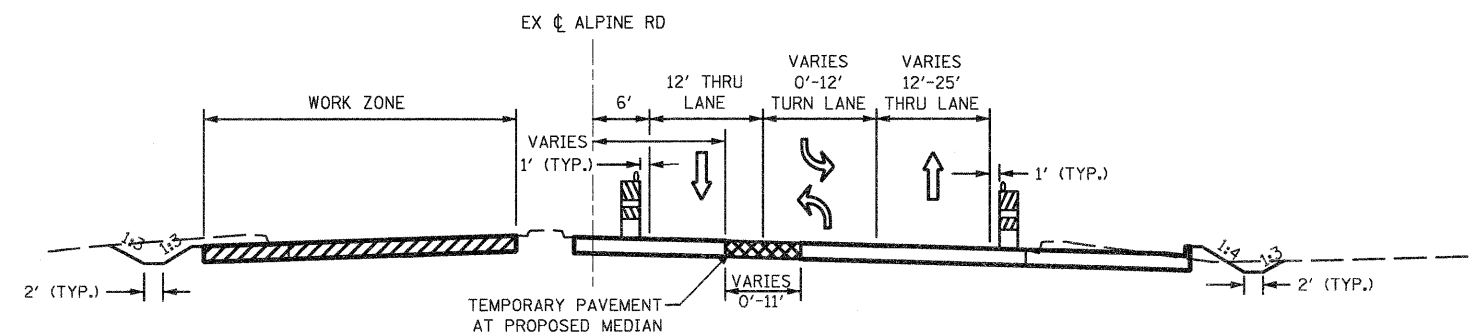

ALPINE RD TYPICAL SECTION
STA 266+75.00 - 273+32.97

NOTE: CONCRETE BARRIER TO BE INSTALLED IN LIEU OF TYPE II BARRICADES BETWEEN STA 269+00.00 AND 270+10.00 (LT) & STA 268+50.00 AND 270+10.00 (RT)

FILE NAME =
D264987-shr-staging-004.dgn

USER NAME = 3202090971

DESIGNED - LOM

REVISED -

DRAWN - MD

REVISED -

PLOT SCALE = 20.0000' / IN.

CHECKED - PDK

REVISED -

PLOT DATE = 1/18/2011

DATE - 01-19-2011

REVISED -

STATE OF ILLINOIS
DEPARTMENT OF TRANSPORTATION

STAGING AND TRAFFIC CONTROL
TYPICAL SECTIONS
STAGE 2A, 2B, 2C

SCALE: N/A SHEET NO. OF SHEETS STA. TO STA.

F.A.P. RTE.	SECTION	COUNTY	TOTAL SHEETS	SHEET NO.
303	129K-1	WINNEBAGO	401	79
CONTRACT NO. 64987				

FED. ROAD DIST. NO. 2 ILLINOIS FED. AID PROJECT

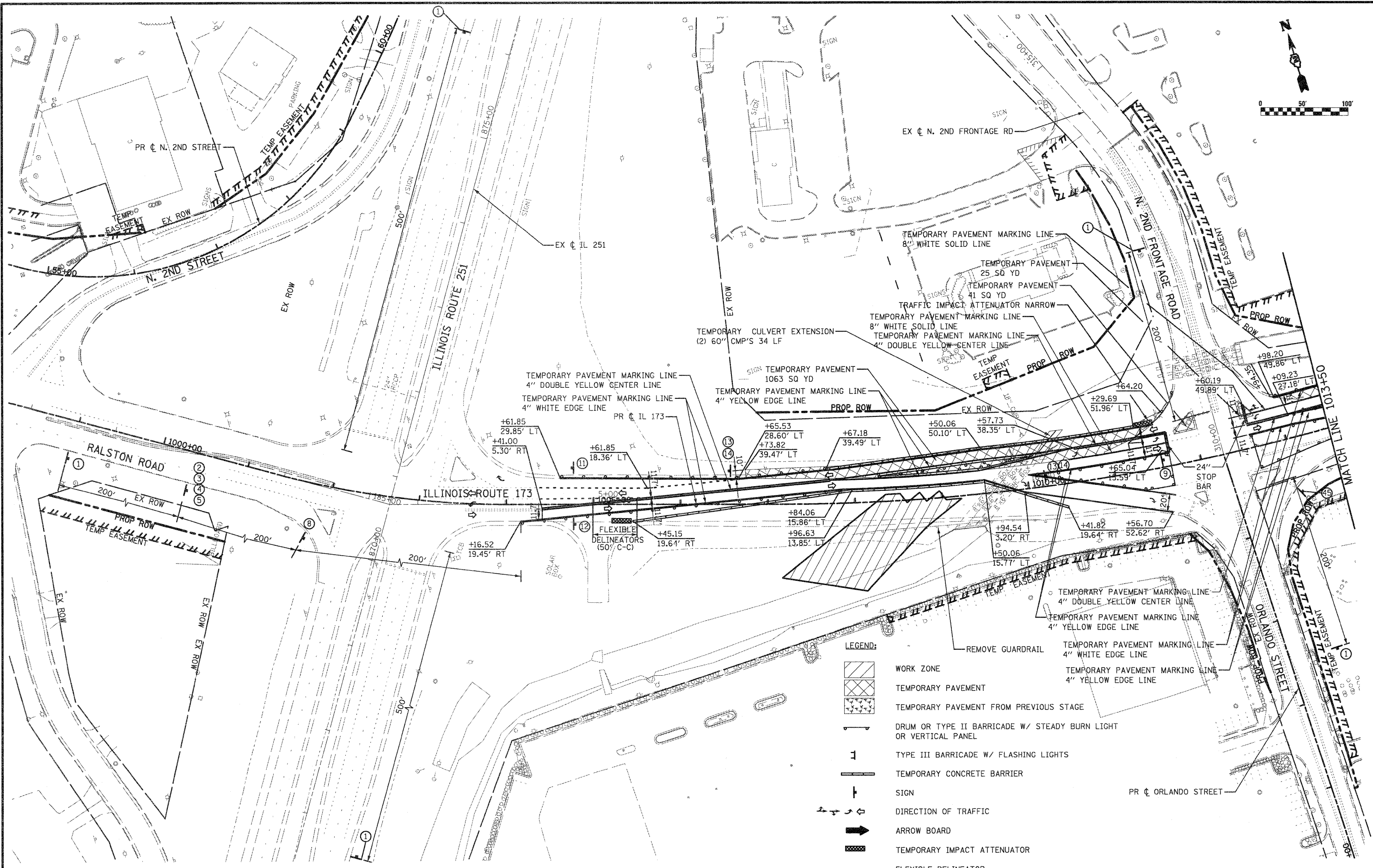
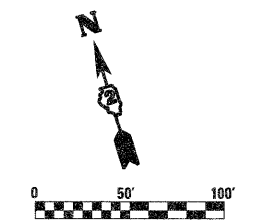

- LEGEND:**
- WORK ZONE
 - TEMPORARY PAVEMENT
 - TEMPORARY PAVEMENT FROM PREVIOUS STAGE
 - DRUM OR TYPE II BARRICADE W/ STEADY BURN LIGHT OR VERTICAL PANEL
 - TYPE III BARRICADE W/ FLASHING LIGHTS
 - TEMPORARY CONCRETE BARRIER
 - SIGN
 - DIRECTION OF TRAFFIC
 - ARROW BOARD
 - TEMPORARY IMPACT ATTENUATOR
 - FLEXIBLE DELINEATOR

FILE NAME =
D264987-shit-staging-011.dgn

USER NAME = 3282090971
PLOT SCALE = 100.0000' / IN.
PLOT DATE = 1/18/2011

DESIGNED - LOM
DRAWN - MD
CHECKED - PDK
DATE - 01-19-2011

REVISED -
REVISED -
REVISED -
REVISED -

**STATE OF ILLINOIS
DEPARTMENT OF TRANSPORTATION**

**STAGING AND TRAFFIC CONTROL PLAN
PRE STAGE 1 - CULVERT CONSTRUCTION
ILLINOIS ROUTE 173**

SCALE: SHEET NO. OF SHEETS STA. 998+00.00 TO STA. 1013+50.00

F.A.P. RTE.	SECTION	COUNTY	TOTAL SHEETS	SHEET NO.
303	129K-1	WINNEBAGO	401	80
CONTRACT NO. 64987			ILLINOIS FED. AID PROJECT	

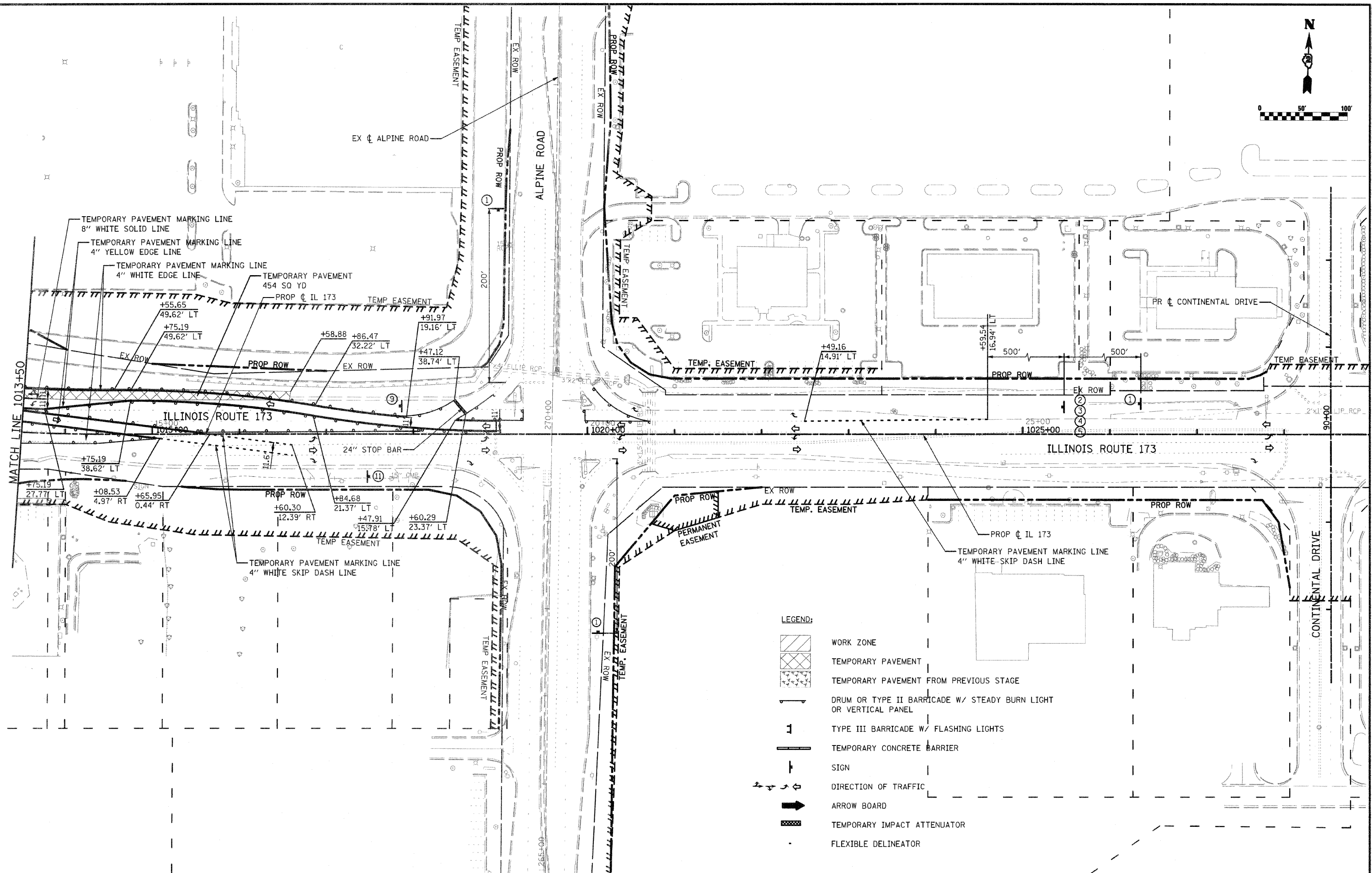
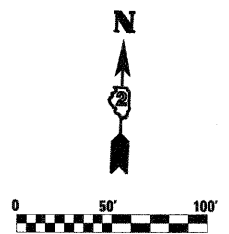

- LEGEND:**
- WORK ZONE
 - TEMPORARY PAVEMENT
 - TEMPORARY PAVEMENT FROM PREVIOUS STAGE
 - DRUM OR TYPE II BARRICADE W/ STEADY BURN LIGHT OR VERTICAL PANEL
 - TYPE III BARRICADE W/ FLASHING LIGHTS
 - TEMPORARY CONCRETE BARRIER
 - SIGN
 - DIRECTION OF TRAFFIC
 - ARROW BOARD
 - TEMPORARY IMPACT ATTENUATOR
 - FLEXIBLE DELINEATOR

FILE NAME = 0264987-shl-staging-012.dgn

USER NAME = 328299971
 PLOT SCALE = 1/8" = 100' / IN.
 PLOT DATE = 3/16/2011

DESIGNED - LOM
 DRAWN - MD
 CHECKED - PDK
 DATE - 03-16-2011

REVISED -
 REVISED -
 REVISED -
 REVISED -

**STATE OF ILLINOIS
 DEPARTMENT OF TRANSPORTATION**

**STAGING AND TRAFFIC CONTROL PLAN
 PRE STAGE 1 - CULVERT CONSTRUCTION
 ILLINOIS ROUTE 173**

SCALE: SHEET NO. OF SHEETS STA. 1013+50 TO STA. 1028+00

F.A.P. RTE.	SECTION	COUNTY	TOTAL SHEETS	SHEET NO.
303	129K-1	WINNEBAGO	401	81
FED. ROAD DIST. NO. 2 ILLINOIS FED. AID PROJECT			CONTRACT NO. 64987	

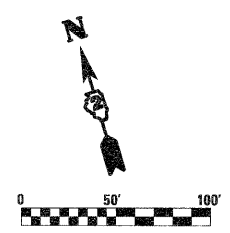
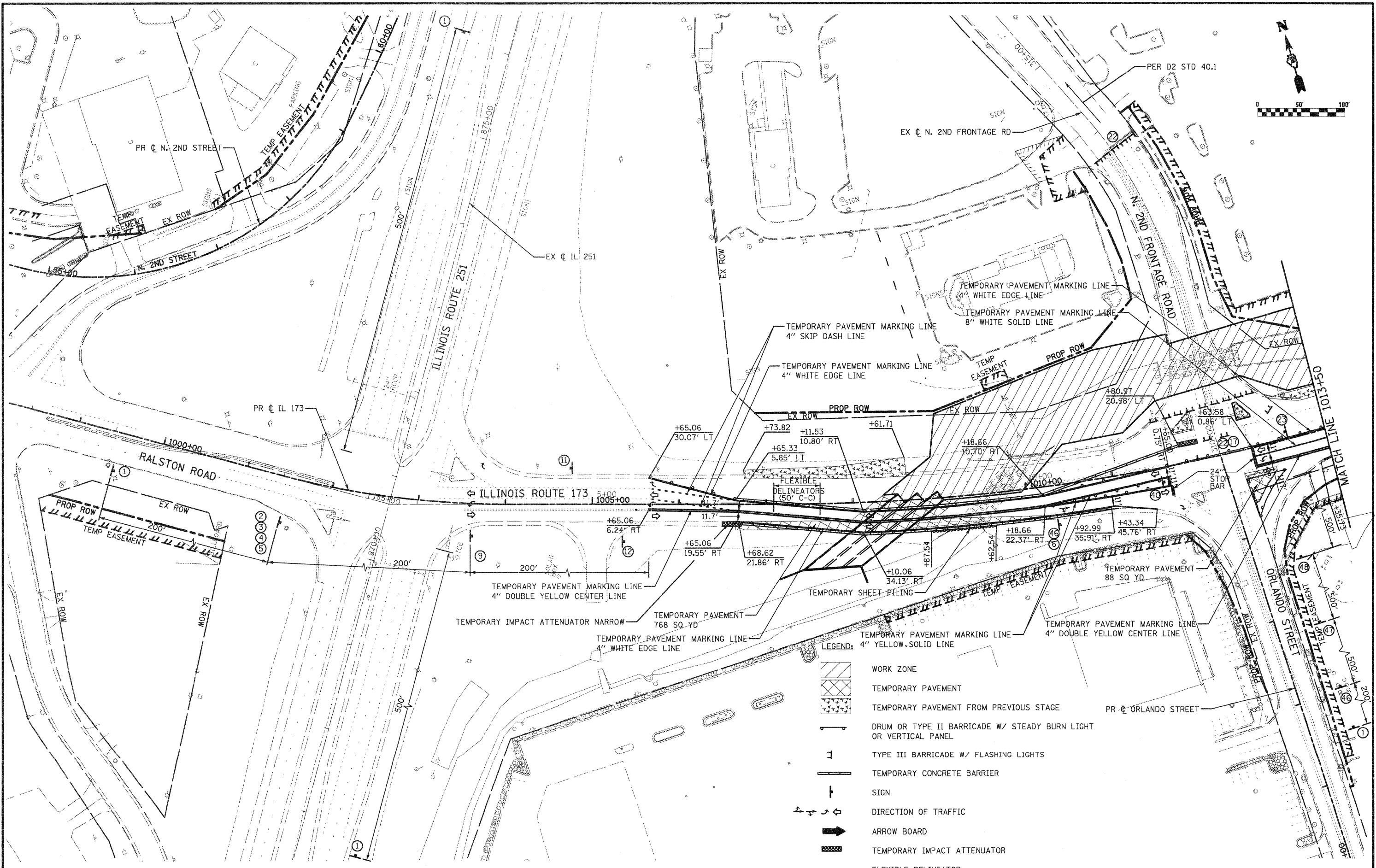

- LEGEND:**
- WORK ZONE
 - TEMPORARY PAVEMENT
 - TEMPORARY PAVEMENT FROM PREVIOUS STAGE
 - DRUM OR TYPE II BARRICADE W/ STEADY BURN LIGHT OR VERTICAL PANEL
 - TYPE III BARRICADE W/ FLASHING LIGHTS
 - TEMPORARY CONCRETE BARRIER
 - SIGN
 - DIRECTION OF TRAFFIC
 - ARROW BOARD
 - TEMPORARY IMPACT ATTENUATOR
 - FLEXIBLE DELINEATOR

FILE NAME = D264987-ahtr-staging-021.dgn
 USER NAME = 328289871
 PLOT SCALE = 100.0000' / IN.
 PLOT DATE = 1/18/2011

DESIGNED - LOM
 DRAWN - MD
 CHECKED - PDK
 DATE - 01-19-2011

REVISED -
 REVISED -
 REVISED -
 REVISED -

**STATE OF ILLINOIS
 DEPARTMENT OF TRANSPORTATION**

**STAGING AND TRAFFIC CONTROL PLAN
 PRE STAGE 2 - CULVERT CONSTRUCTION
 ILLINOIS ROUTE 173**

SCALE: SHEET NO. OF SHEETS STA. 998+00.00 TO STA. 1013+50.00

F.A.P. RTE.	SECTION	COUNTY	TOTAL SHEETS	SHEET NO.
303	129K-1	WINNEBAGO	401	82

CONTRACT NO. 64987
 FED. ROAD DIST. NO. 2 ILLINOIS FED. AID PROJECT

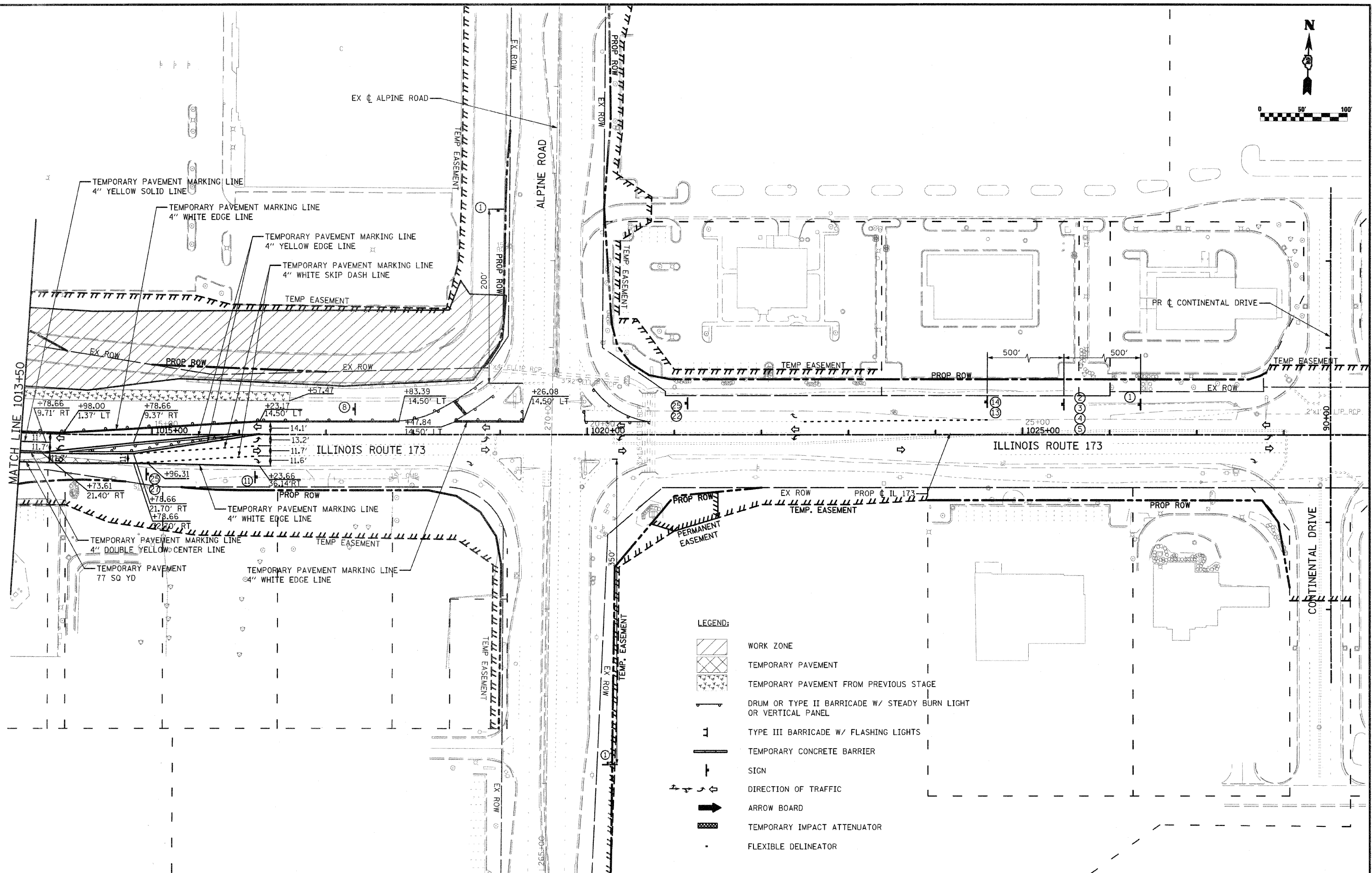
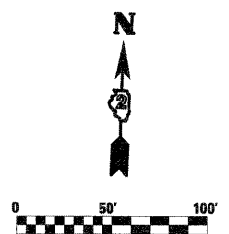

- LEGEND:**
- WORK ZONE
 - TEMPORARY PAVEMENT
 - TEMPORARY PAVEMENT FROM PREVIOUS STAGE
 - DRUM OR TYPE II BARRICADE W/ STEADY BURN LIGHT OR VERTICAL PANEL
 - TYPE III BARRICADE W/ FLASHING LIGHTS
 - TEMPORARY CONCRETE BARRIER
 - SIGN
 - DIRECTION OF TRAFFIC
 - ARROW BOARD
 - TEMPORARY IMPACT ATTENUATOR
 - FLEXIBLE DELINEATOR

FILE NAME = D264987-shr-staging-022.dgn	USER NAME = 3282890771	DESIGNED LOM	REVISOR
		DRAWN MD	REVISOR
		CHECKED PDK	REVISOR
		DATE 03-16-2011	REVISOR

**STATE OF ILLINOIS
DEPARTMENT OF TRANSPORTATION**

**STAGING AND TRAFFIC CONTROL PLAN
PRE STAGE 2 - CULVERT CONSTRUCTION
ILLINOIS ROUTE 173**

SCALE: SHEET NO. OF SHEETS STA. 1013+50 TO STA. 1028+00

F.A.P. RTE.	SECTION	COUNTY	TOTAL SHEETS	SHEET NO.
303	129K-1	WINNEBAGO	401	83
CONTRACT NO. 64987				
FED. ROAD DIST. NO. 2 ILLINOIS FED. AID PROJECT				

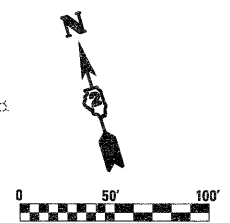
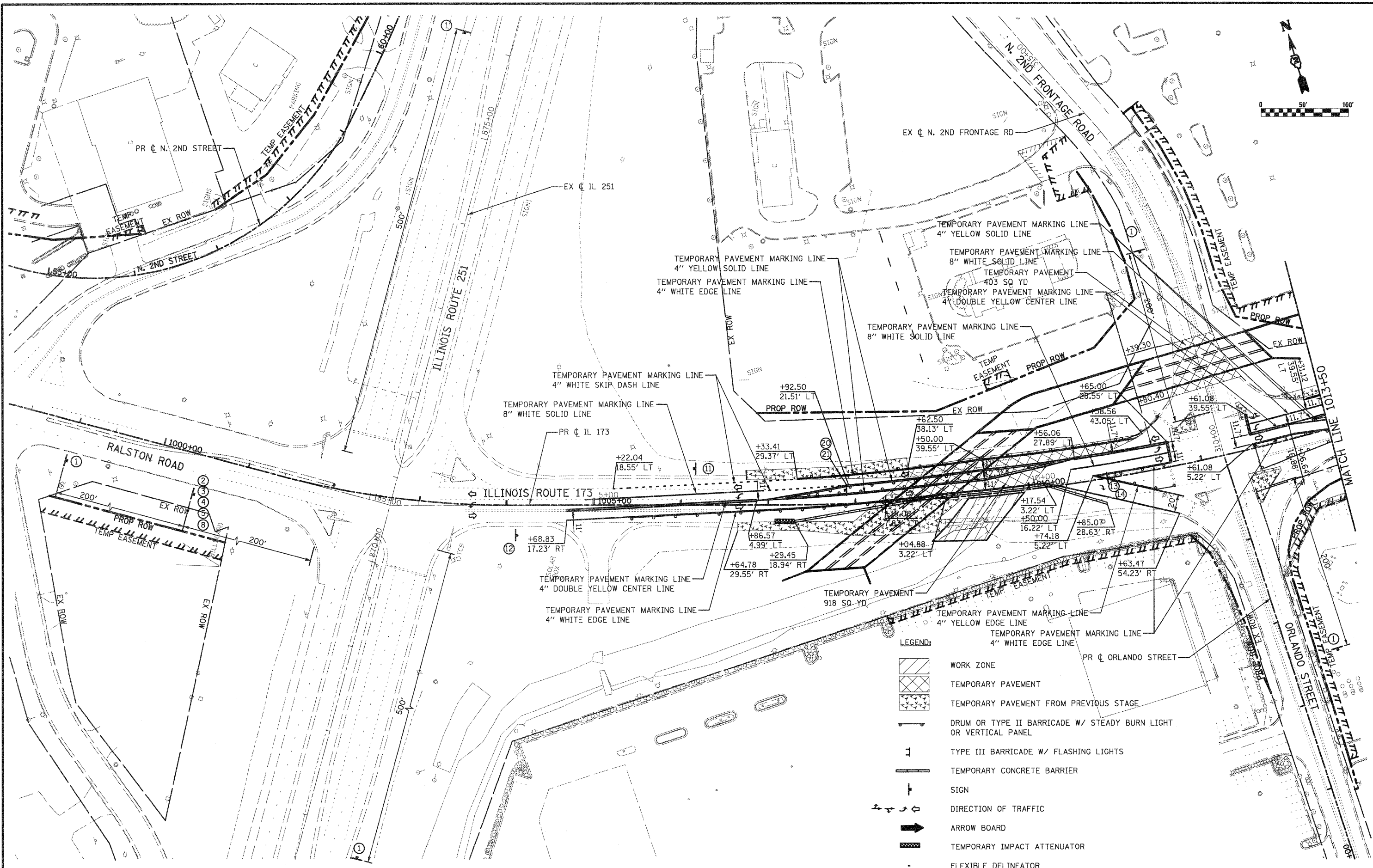

FILE NAME = D264987-shr-staging-031.dgn
 USER NAME = 3282090971

DESIGNED - LOM
 DRAWN - MD
 CHECKED - PDK
 DATE - 01-19-2011

REVISED -
 REVISED -
 REVISED -
 REVISED -

**STATE OF ILLINOIS
 DEPARTMENT OF TRANSPORTATION**

**STAGING AND TRAFFIC CONTROL PLAN
 PRE STAGE 3 - CULVERT CONSTRUCTION
 ILLINOIS ROUTE 173**

SCALE: SHEET NO. OF SHEETS STA. 998+00.00 TO STA. 1013+50.00

F.A.P. RTE.	SECTION	COUNTY	TOTAL SHEETS	SHEET NO.
303	129K-1	WINNEBAGO	401	84
				CONTRACT NO. 64987

FED. ROAD DIST. NO. 2 ILLINOIS FED. AID PROJECT

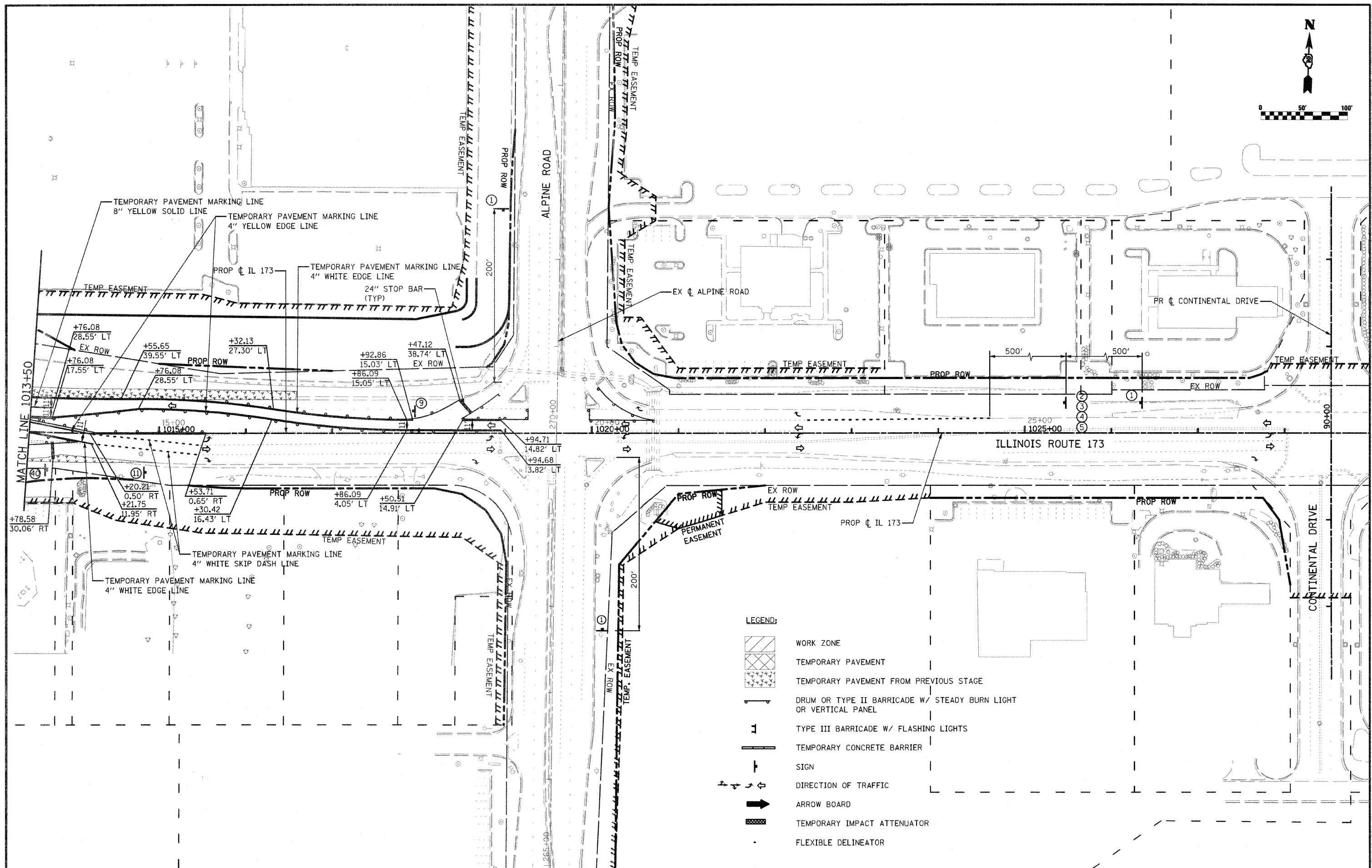
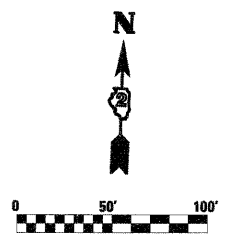

- LEGEND:**
- WORK ZONE
 - TEMPORARY PAVEMENT
 - TEMPORARY PAVEMENT FROM PREVIOUS STAGE
 - DRUM OR TYPE II BARRICADE W/ STEADY BURN LIGHT OR VERTICAL PANEL
 - TYPE III BARRICADE W/ FLASHING LIGHTS
 - TEMPORARY CONCRETE BARRIER
 - SIGN
 - DIRECTION OF TRAFFIC
 - ARROW BOARD
 - TEMPORARY IMPACT ATTENUATOR
 - FLEXIBLE DELINEATOR

FILE NAME = 0264987-ah-ts-tagging-032.dgn

USER NAME = 320289877
 PLOT SCALE = 100.0000' / IN.
 PLOT DATE = 3/16/2011

DESIGNED - LOM
 DRAWN - MD
 CHECKED - PDK
 DATE - 03-16-2011

REVISED -
 REVISED -
 REVISED -
 REVISED -









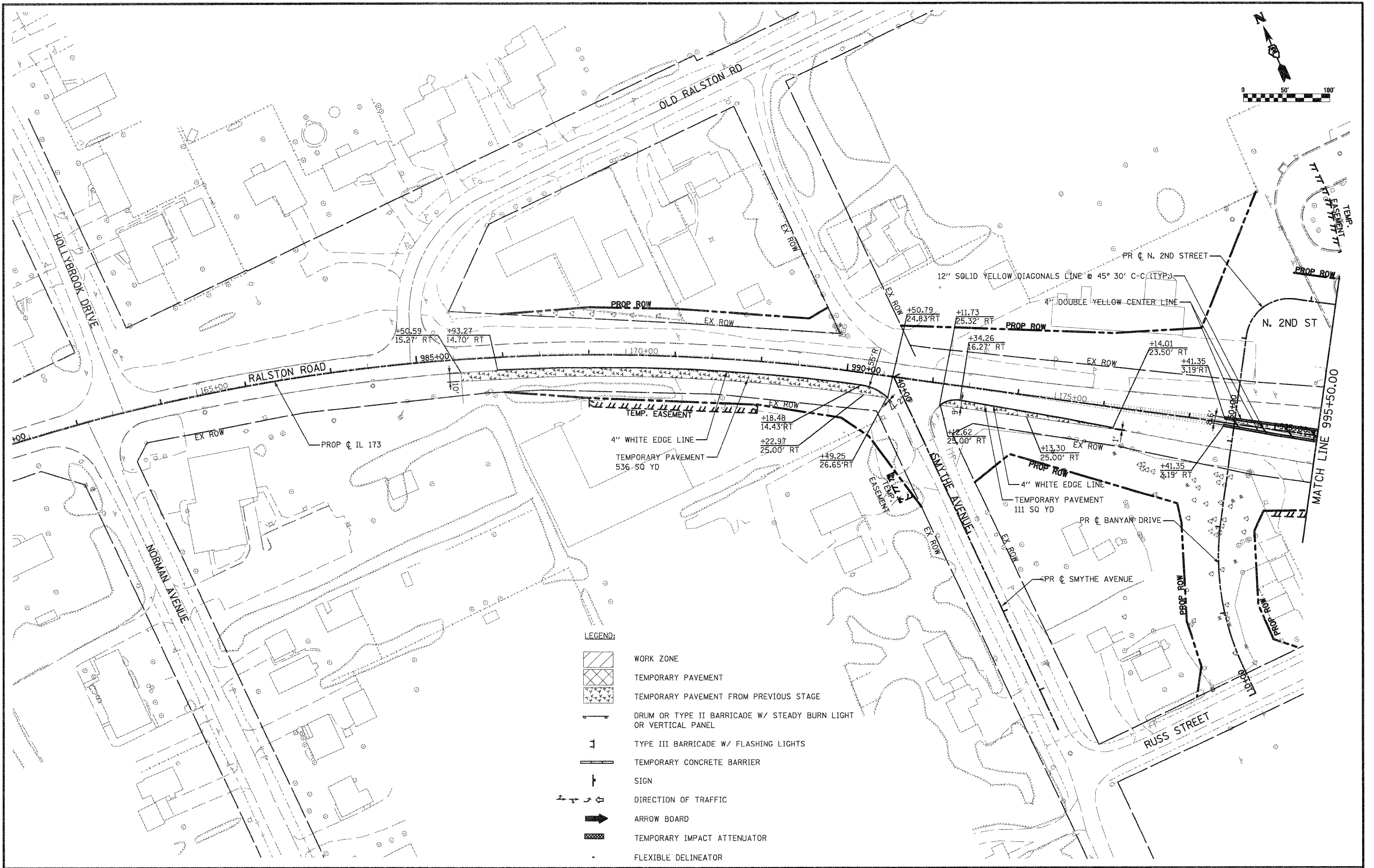

**STATE OF ILLINOIS
 DEPARTMENT OF TRANSPORTATION**

**STAGING AND TRAFFIC CONTROL PLAN
 PRE STAGE 3 - CULVERT CONSTRUCTION
 ILLINOIS ROUTE 173**

SCALE: SHEET NO. OF SHEETS STA. 1013+50 TO STA. 1028+00

F.A.P. RTE.	SECTION	COUNTY	TOTAL SHEETS	SHEET NO.
303	129K-1	WINNEBAGO	401	85
CONTRACT NO. 64987				
FED. ROAD DIST. NO. 2 ILLINOIS FED. AID PROJECT				



- LEGEND:**
-  WORK ZONE
 -  TEMPORARY PAVEMENT
 -  TEMPORARY PAVEMENT FROM PREVIOUS STAGE
 -  DRUM OR TYPE II BARRICADE W/ STEADY BURN LIGHT OR VERTICAL PANEL
 -  TYPE III BARRICADE W/ FLASHING LIGHTS
 -  TEMPORARY CONCRETE BARRIER
 -  SIGN
 -  DIRECTION OF TRAFFIC
 -  ARROW BOARD
 -  TEMPORARY IMPACT ATTENUATOR
 -  FLEXIBLE DELINEATOR

FILE NAME =
D264987-shtrstaging-041.dgn

USER NAME = 3202090971
PLOT SCALE = 100.0000' / IN.
PLOT DATE = 1/18/2011

DESIGNED - LOM
DRAWN - MD
CHECKED - PDK
DATE - 01-19-2011

REVISED -
REVISED -
REVISED -
REVISED -

**STATE OF ILLINOIS
DEPARTMENT OF TRANSPORTATION**

**STAGING AND TRAFFIC CONTROL PLAN
WINTER SHUT DOWN
RALSTON ROAD**

SCALE: SHEET NO. OF SHEETS STA. 980+50.00 TO STA. 995+50.00

F.A.P. RTE.	SECTION	COUNTY	TOTAL SHEETS	SHEET NO.
303	129K-1	WINNEBAGO	401	86
CONTRACT NO. 64987				

FED. ROAD DIST. NO. 2 ILLINOIS FED. AID PROJECT

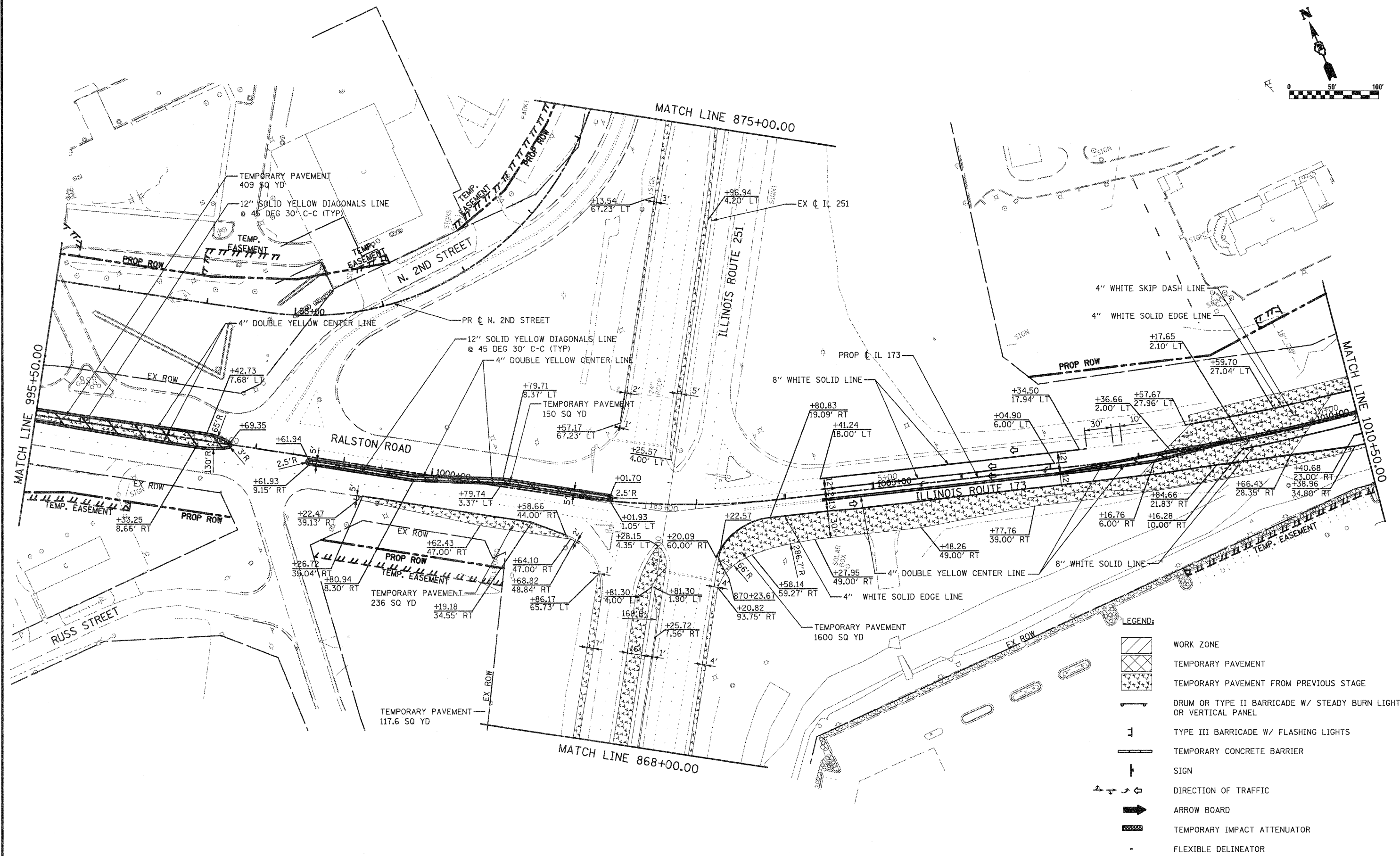
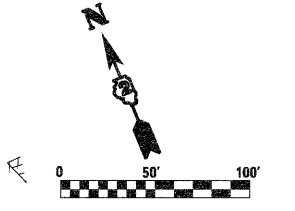

- LEGEND:**
- WORK ZONE
 - TEMPORARY PAVEMENT
 - TEMPORARY PAVEMENT FROM PREVIOUS STAGE
 - DRUM OR TYPE II BARRICADE W/ STEADY BURN LIGHT OR VERTICAL PANEL
 - TYPE III BARRICADE W/ FLASHING LIGHTS
 - TEMPORARY CONCRETE BARRIER
 - SIGN
 - DIRECTION OF TRAFFIC
 - ARROW BOARD
 - TEMPORARY IMPACT ATTENUATOR
 - FLEXIBLE DELINEATOR



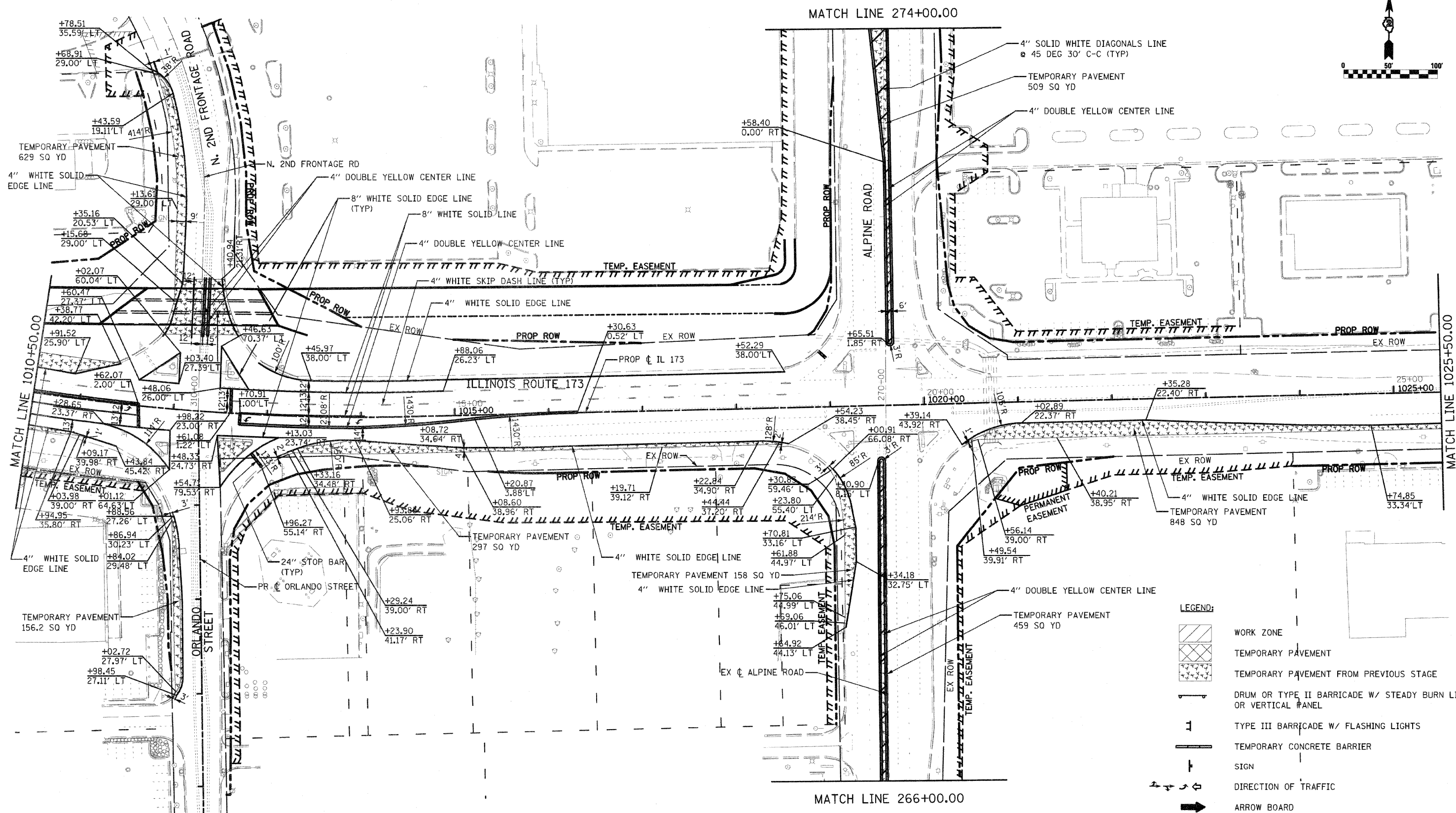
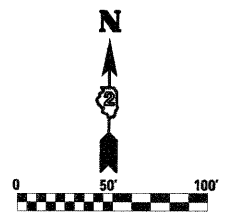





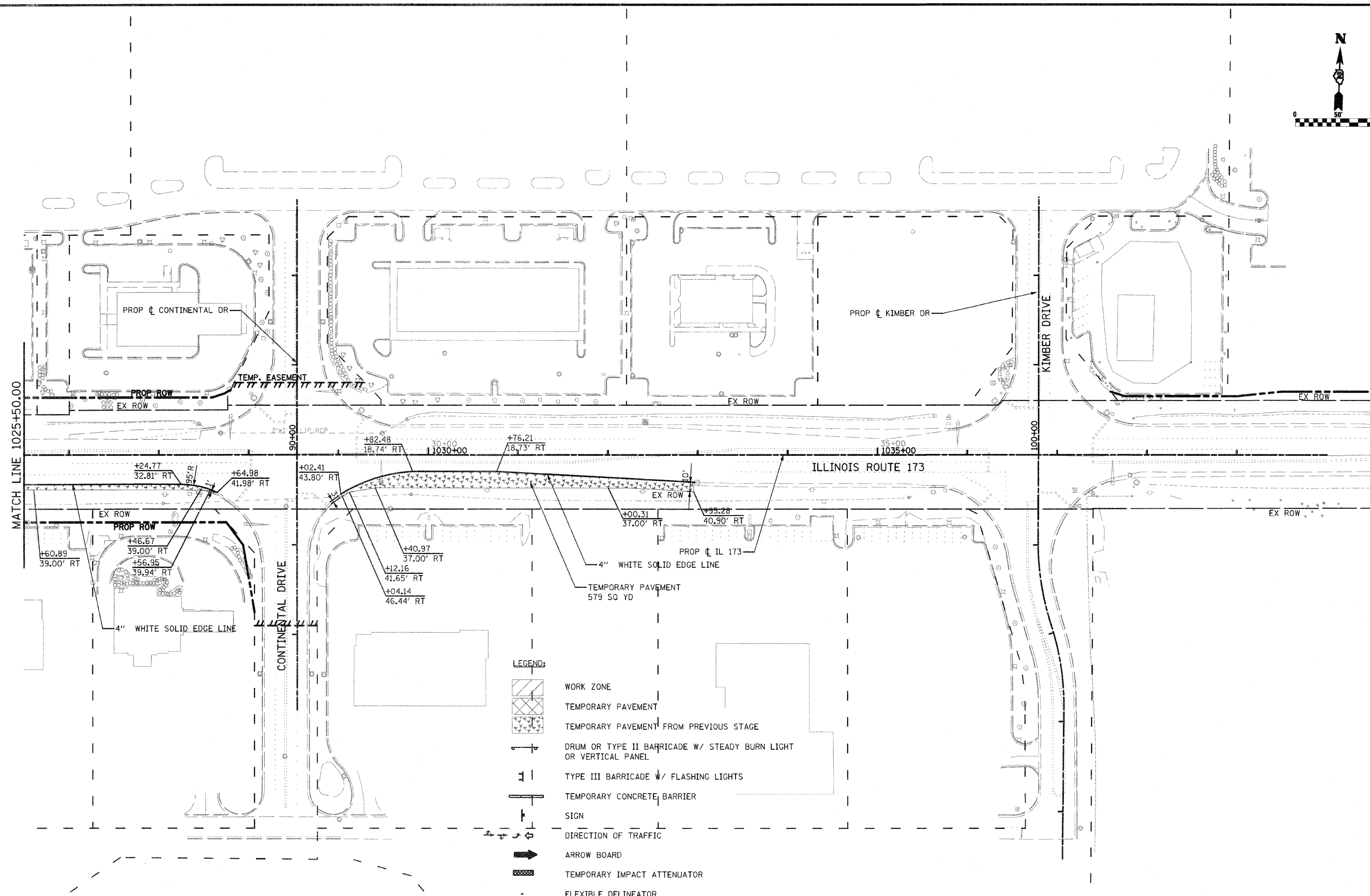
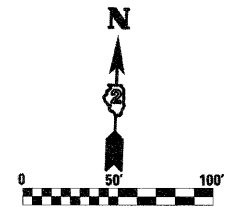

FILE NAME = D264987-shr-staging-042.dgn	USER NAME = 3202090971	DESIGNED - LOM	REVISED -	STATE OF ILLINOIS DEPARTMENT OF TRANSPORTATION	STAGING AND TRAFFIC CONTROL PLAN WINTER SHUT DOWN RALSTON ROAD \ ILLINOIS ROUTE 173			F.A.P. RTE. = 303	SECTION = 129K-1	COUNTY = WINNEBAGO	TOTAL SHEETS = 401	SHEET NO. = 87
	PLDT SCALE = 1/8" = 100.0000' / IN.	CHECKED - PDK	REVISED -		SCALE:	SHEET NO. OF SHEETS	STA. 995+50.00 TO STA. 1010+50.00	FED. ROAD DIST. NO. 2	ILLINOIS FED. AID PROJECT	CONTRACT NO. 64987		
PLDT DATE = 1/19/2011	DATE = 01-19-2011	REVISED -	REVISED -									



- LEGEND:**
- WORK ZONE
 - TEMPORARY PAVEMENT
 - TEMPORARY PAVEMENT FROM PREVIOUS STAGE
 - DRUM OR TYPE II BARRICADE W/ STEADY BURN LIGHT OR VERTICAL PANEL
 - TYPE III BARRICADE W/ FLASHING LIGHTS
 - TEMPORARY CONCRETE BARRIER
 - SIGN
 - DIRECTION OF TRAFFIC
 - ARROW BOARD
 - TEMPORARY IMPACT ATTENUATOR
 - FLEXIBLE DELINEATOR

FILE NAME = 0264987-shr-staging-043.dgn	USER NAME = 328229071	DESIGNED - LOM	REVISIONS	STATE OF ILLINOIS DEPARTMENT OF TRANSPORTATION	STAGING AND TRAFFIC CONTROL PLAN WINTER SHUT DOWN ILLINOIS ROUTE 173			F.A.P. RTE. 303	SECTION 129K-1	COUNTY WINNEBAGO	TOTAL SHEETS 401	SHEET NO. 88
	PLOT SCALE = 1/8" = 100'-0"	DRAWN - MD	REVISIONS		SCALE:	SHEET NO.	OF SHEETS	STA. 1010+50.00 TO STA. 1025+50.00	CONTRACT NO. 64987			
	PLOT DATE = 3/16/2011	CHECKED - PDK	REVISIONS						FED. ROAD DIST. NO. 2 ILLINOIS FED. AID PROJECT			
		DATE - 03-16-2011	REVISIONS									



- LEGEND:**
-  WORK ZONE
 -  TEMPORARY PAVEMENT
 -  TEMPORARY PAVEMENT FROM PREVIOUS STAGE
 -  DRUM OR TYPE II BARRICADE W/ STEADY BURN LIGHT OR VERTICAL PANEL
 -  TYPE III BARRICADE W/ FLASHING LIGHTS
 -  TEMPORARY CONCRETE BARRIER
 -  SIGN
 -  DIRECTION OF TRAFFIC
 -  ARROW BOARD
 -  TEMPORARY IMPACT ATTENUATOR
 -  FLEXIBLE DELINEATOR

FILE NAME = 0264987-shr-staging-244.dgn

USER NAME = 3282898971
 PLOT SCALE = 100.0000' / IN.
 PLOT DATE = 3/16/2011

DESIGNED - LOM
 DRAWN - MD
 CHECKED - PDK
 DATE - 03-16-2011

REVISED -
 REVISED -
 REVISED -
 REVISED -

**STATE OF ILLINOIS
 DEPARTMENT OF TRANSPORTATION**

**STAGING AND TRAFFIC CONTROL PLAN
 WINTER SHUT DOWN
 ILLINOIS ROUTE 173**

SCALE: SHEET NO. OF SHEETS STA. 1025+50.00 TO STA. 1040+00.00

F.A.P. RTE.	SECTION	COUNTY	TOTAL SHEETS	SHEET NO.
303	129K-1	WINNEBAGO	401	89
CONTRACT NO. 64987			FED. ROAD DIST. NO. 2 ILLINOIS FED. AID PROJECT	

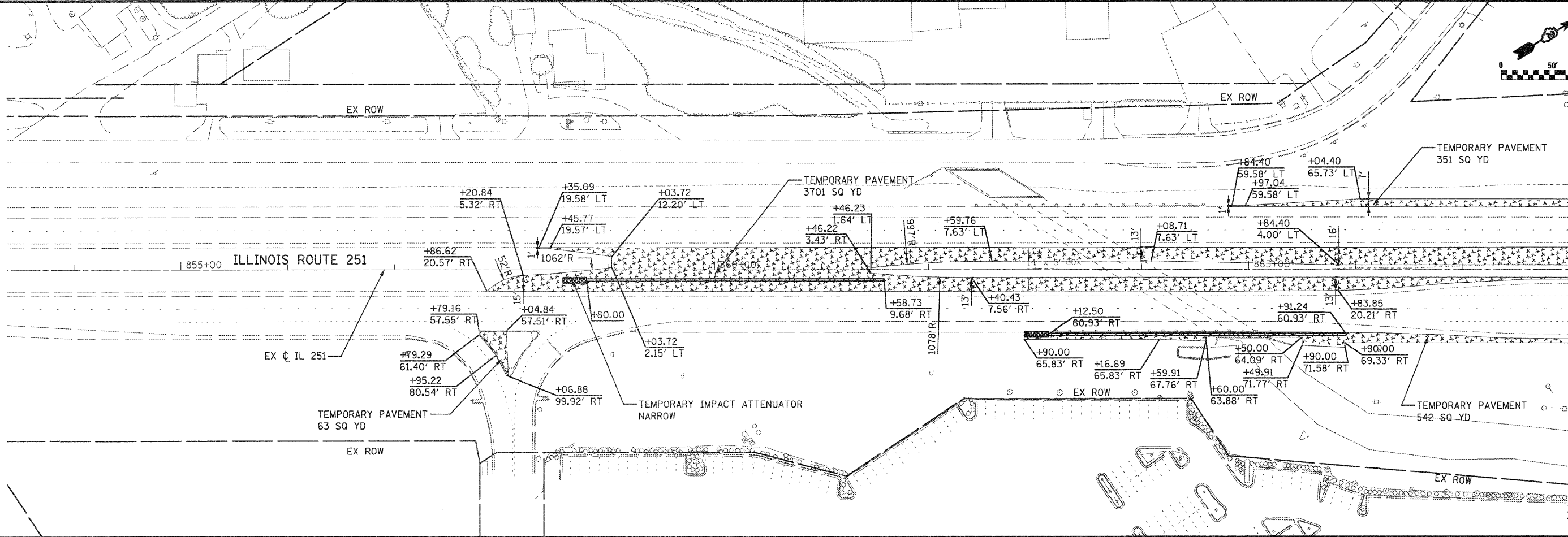

MATCH LINE 868+00.00

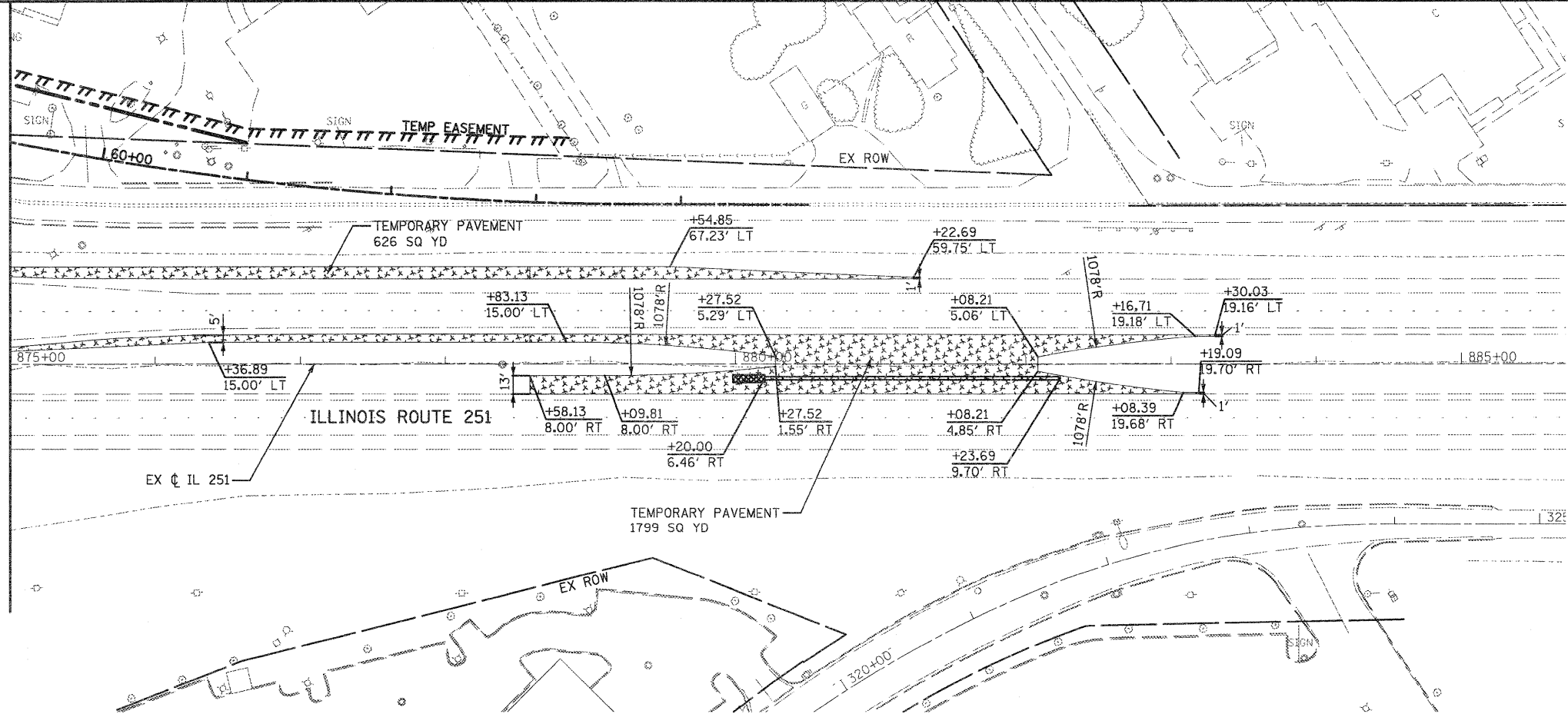

MATCH LINE 875+00.00

- LEGEND:**
- WORK ZONE
 - TEMPORARY PAVEMENT
 - TEMPORARY PAVEMENT FROM PREVIOUS STAGE
 - DRUM OR TYPE II BARRICADE W/ STEADY BURN LIGHT OR VERTICAL PANEL
 - TYPE III BARRICADE W/ FLASHING LIGHTS
 - TEMPORARY CONCRETE BARRIER
 - SIGN
 - DIRECTION OF TRAFFIC
 - ARROW BOARD
 - TEMPORARY IMPACT ATTENUATOR
 - FLEXIBLE DELINEATOR

FILE NAME = 0264987-shr-staging-045.dgn

USER NAME = 3202090971
 PLOT SCALE = 100.0000' / IN.
 PLOT DATE = 1/18/2011

DESIGNED - LOM
 DRAWN - MD
 CHECKED - PDK
 DATE - 01-19-2011

REVISED -
 REVISED -
 REVISED -
 REVISED -

**STATE OF ILLINOIS
 DEPARTMENT OF TRANSPORTATION**

**STAGING AND TRAFFIC CONTROL PLAN
 WINTER SHUT DOWN
 ILLINOIS ROUTE 251**

SCALE: SHEET NO. OF SHEETS STA. 875+00.00 TO STA. 885+00.00

F.A.P. RTE.	SECTION	COUNTY	TOTAL SHEETS	SHEET NO.
303	129K-1	WINNEBAGO	401	90

CONTRACT NO. 64987

FED. ROAD DIST. NO. 2 ILLINOIS FED. AID PROJECT

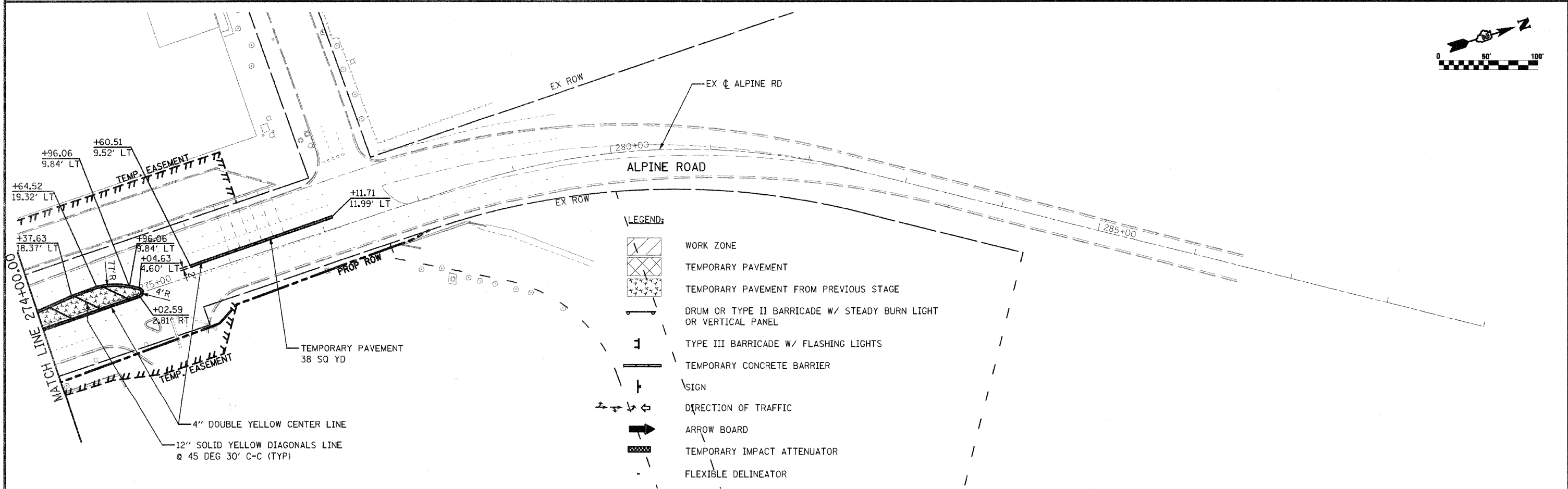
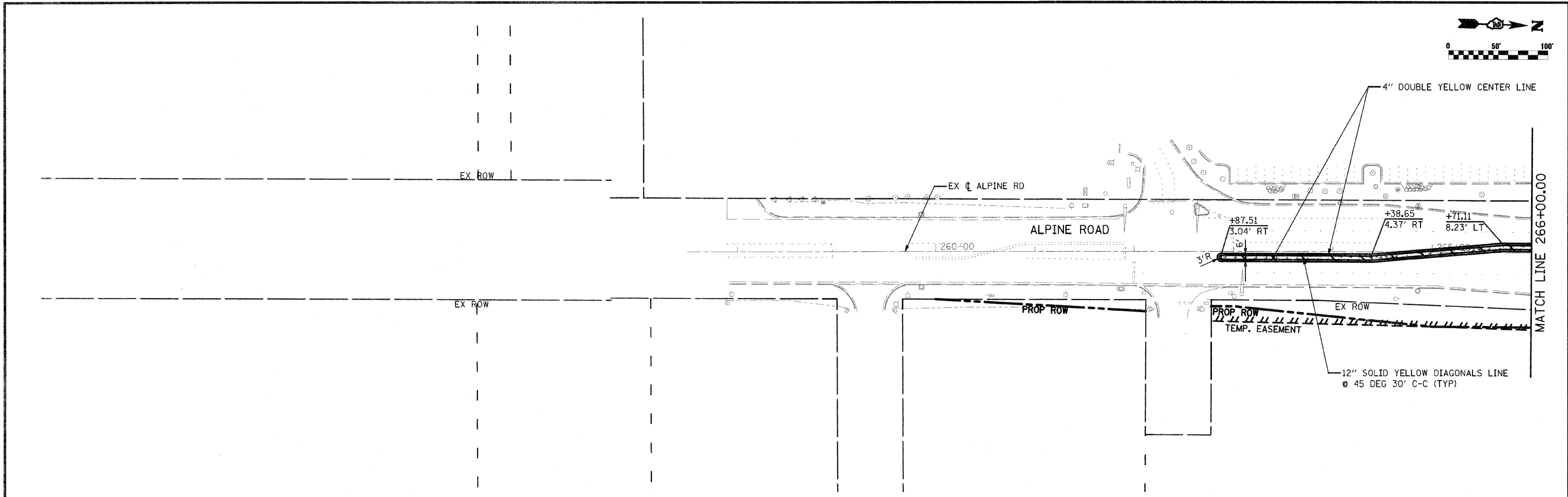

FILE NAME = D264987-shr-staging-046.dgn	USER NAME = 32029071	DESIGNED - LOM	REVISED -	STATE OF ILLINOIS DEPARTMENT OF TRANSPORTATION	STAGING AND TRAFFIC CONTROL PLAN WINTER SHUT DOWN ALPINE ROAD			F.A.P. RTE. 303	SECTION 129K-1	COUNTY WINNEBAGO	TOTAL SHEET SHEETS NO. 401 91	
	PLOT SCALE = 100.0000' / IN.	DRAWN - MD	REVISED -		SCALE:	SHEET NO. OF SHEETS	STA. 251+00.00 TO STA. 289+00.00	CONTRACT NO. 64987				
	PLOT DATE = 3/16/2011	CHECKED - PDK	REVISED -		FED. ROAD DIST. NO. 2 ILLINOIS FED. AID PROJECT							
		DATE - 03-16-2011	REVISED -									

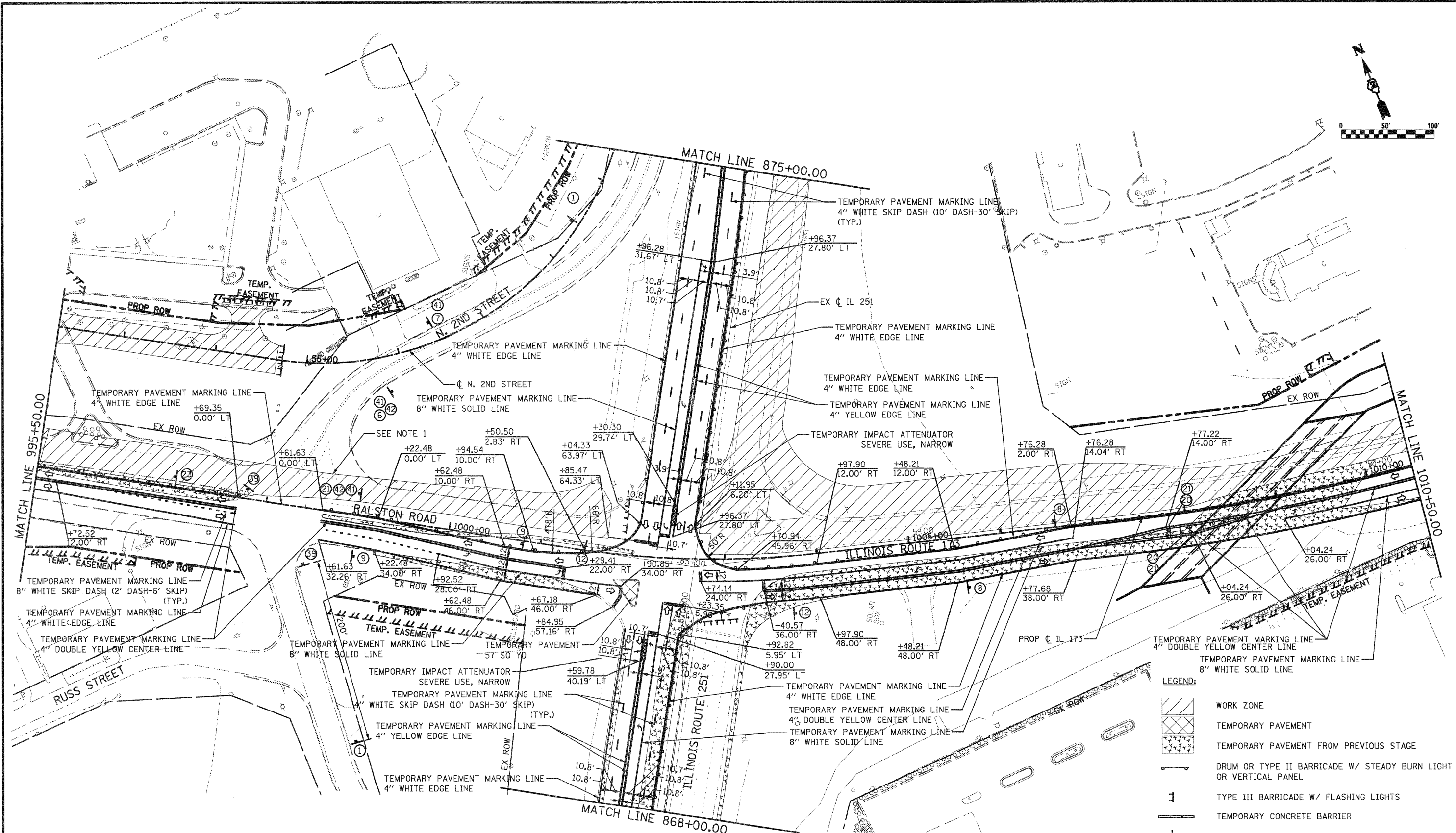
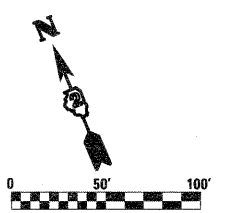

NOTE:
 1. IL 173/N 2ND STREET INTERSECTION WILL BE STAGE CONSTRUCTED TO PROVIDE ACCESS TO TRUCKS AT ALL TIMES. CONSTRUCTION LAYOUT SHALL BE SUBJECT TO THE ENGINEER'S APPROVAL.

- LEGEND:**
- WORK ZONE
 - TEMPORARY PAVEMENT
 - TEMPORARY PAVEMENT FROM PREVIOUS STAGE
 - DRUM OR TYPE II BARRICADE W/ STEADY BURN LIGHT OR VERTICAL PANEL
 - TYPE III BARRICADE W/ FLASHING LIGHTS
 - TEMPORARY CONCRETE BARRIER
 - SIGN
 - DIRECTION OF TRAFFIC
 - ARROW BOARD
 - TEMPORARY IMPACT ATTENUATOR
 - FLEXIBLE DELINEATOR

FILE NAME =
 0264987-sh1-staging-102.dgn

USER NAME = 328290971
 PLOT SCALE = 100.0000' / IN.
 PLOT DATE = 1/18/2011

DESIGNED - LOM
 DRAWN - MD
 CHECKED - PDK
 DATE - 01-19-2011

REVISED -
 REVISED -
 REVISED -
 REVISED -

**STATE OF ILLINOIS
 DEPARTMENT OF TRANSPORTATION**

**STAGING AND TRAFFIC CONTROL PLAN
 STAGE 1A
 RALSTON ROAD / ILLINOIS ROUTE 173**

SCALE: 1" = 50' SHEET NO. OF SHEETS STA. 995+50.00 TO STA. 1010+50.00

F.A.P. RTE.	SECTION	COUNTY	TOTAL SHEETS	SHEET NO.
303	129K-1	WINNEBAGO	401	93

CONTRACT NO. 64987
 FED. ROAD DIST. NO. 2 ILLINOIS FED. AID PROJECT

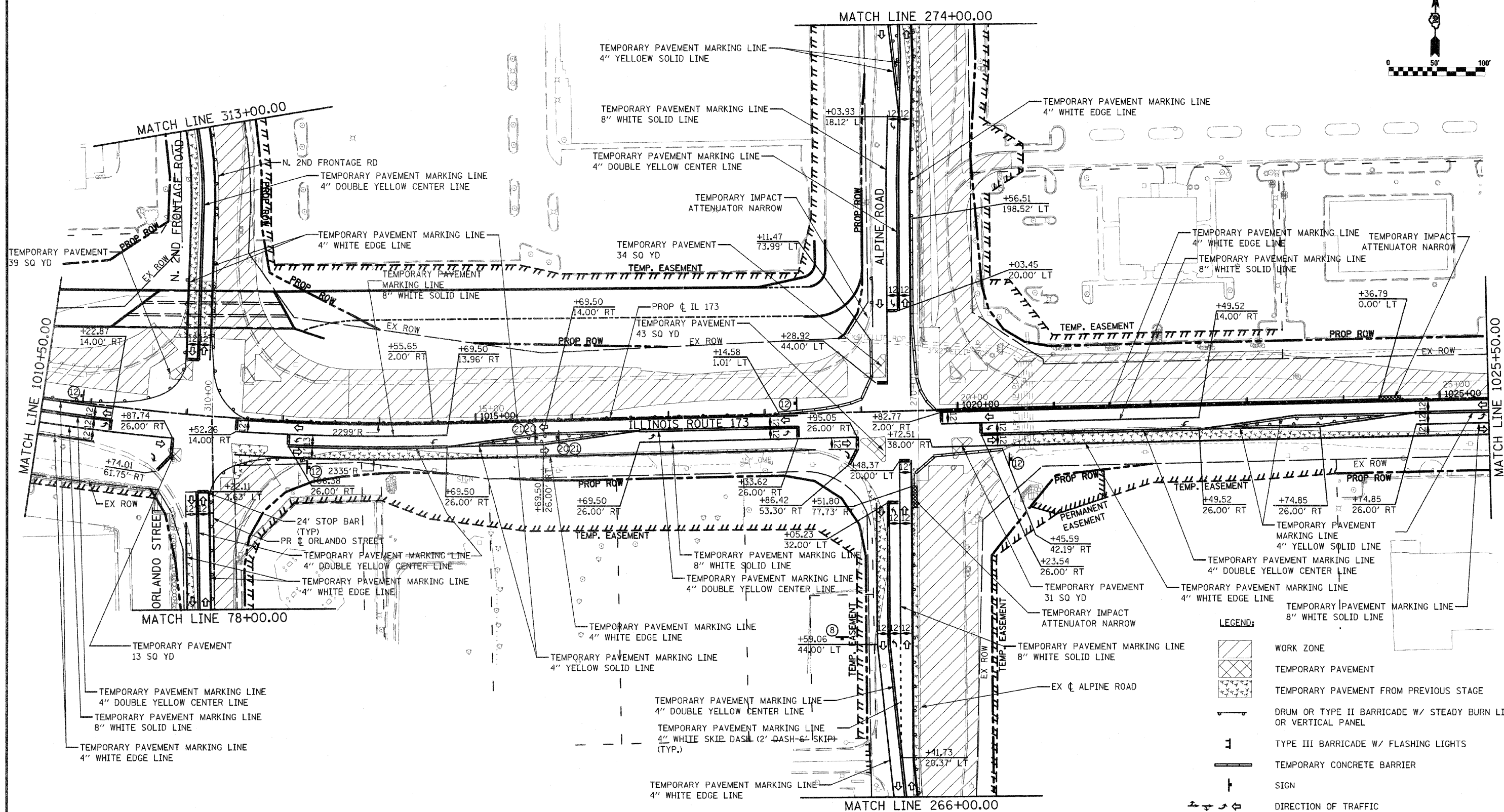
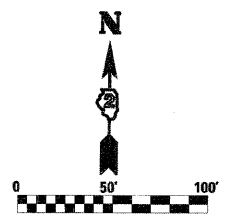

- LEGEND:**
- WORK ZONE
 - TEMPORARY PAVEMENT
 - TEMPORARY PAVEMENT FROM PREVIOUS STAGE
 - DRUM OR TYPE II BARRICADE W/ STEADY BURN LIGHT OR VERTICAL PANEL
 - TYPE III BARRICADE W/ FLASHING LIGHTS
 - TEMPORARY CONCRETE BARRIER
 - SIGN
 - DIRECTION OF TRAFFIC
 - ARROW BOARD
 - TEMPORARY IMPACT ATTENUATOR
 - FLEXIBLE DELINEATOR

FILE NAME = 0264987-shd-staging-103.dgn
 USER NAME = 328289071
 PLOT SCALE = 100.0000' / IN.
 PLOT DATE = 3/16/2011

DESIGNED - LOM
 DRAWN - MD
 CHECKED - PDK
 DATE - 03-16-2011

REVISED -
 REVISED -
 REVISED -
 REVISED -

**STATE OF ILLINOIS
 DEPARTMENT OF TRANSPORTATION**

**STAGING AND TRAFFIC CONTROL PLAN
 STAGE 1A
 ILLINOIS ROUTE 173**

SCALE: SHEET NO. OF SHEETS STA. 1010+50.00 TO STA. 1025+50.00

F.A.P. RTE.	SECTION	COUNTY	TOTAL SHEETS	SHEET NO.
303	129K-1	WINNEBAGO	401	94
FED. ROAD DIST. NO. 2 ILLINOIS FED. AID PROJECT				CONTRACT NO. 64987

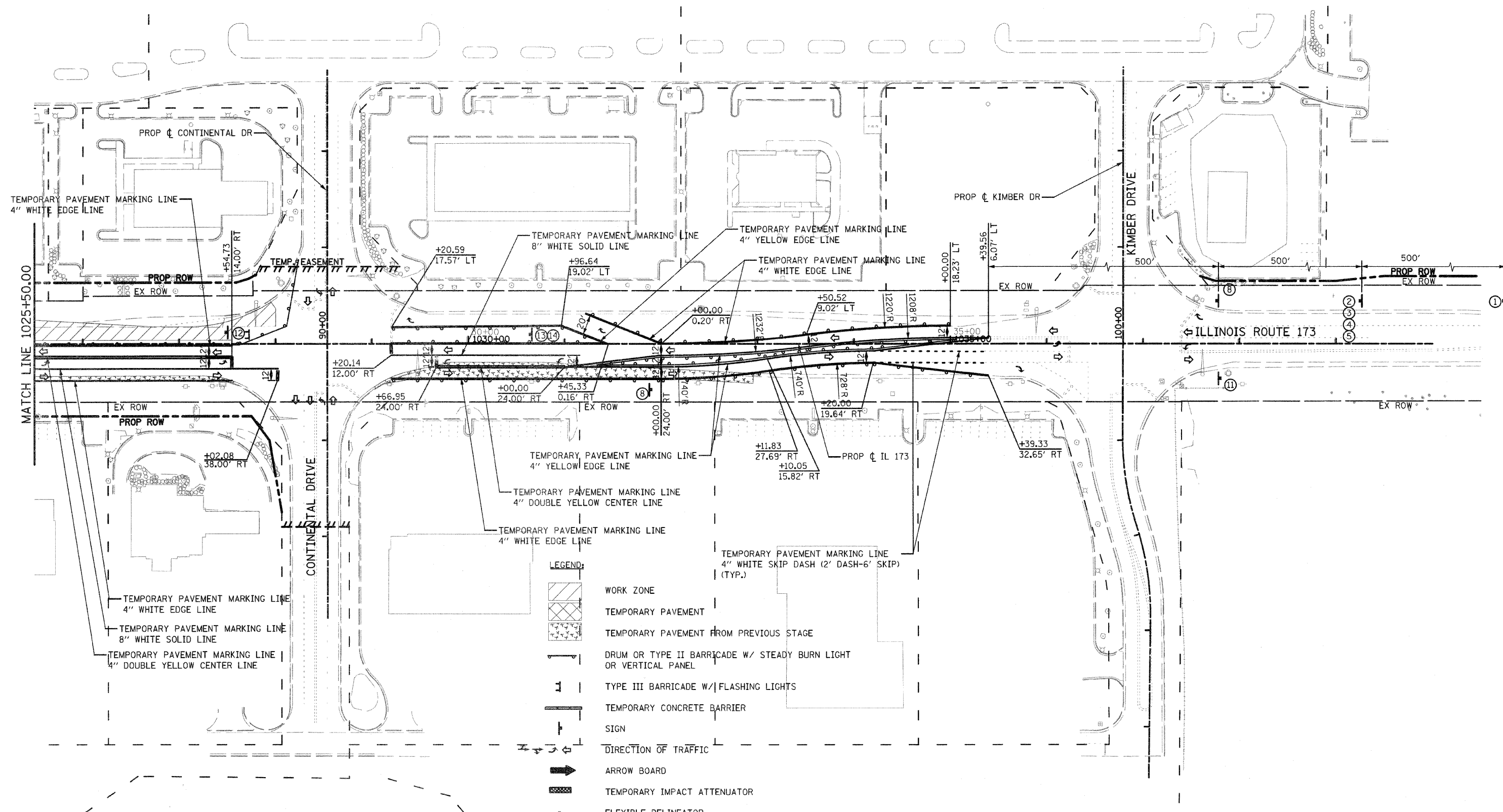
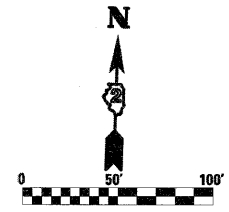

- LEGEND:**
- WORK ZONE
 - TEMPORARY PAVEMENT
 - TEMPORARY PAVEMENT FROM PREVIOUS STAGE
 - DRUM OR TYPE II BARRICADE W/ STEADY BURN LIGHT OR VERTICAL PANEL
 - TYPE III BARRICADE W/ FLASHING LIGHTS
 - TEMPORARY CONCRETE BARRIER
 - SIGN
 - DIRECTION OF TRAFFIC
 - ARROW BOARD
 - TEMPORARY IMPACT ATTENUATOR
 - FLEXIBLE DELINEATOR

FILE NAME =
0264987-ah-staging-104.dgn

USER NAME = 320289871
PLOT SCALE = 1/8" = 100.0000' / IN.
PLOT DATE = 3/16/2011

DESIGNED - LOM
DRAWN - MD
CHECKED - PDK
DATE - 03-16-2011

REVISED -
REVISED -
REVISED -
REVISED -

**STATE OF ILLINOIS
DEPARTMENT OF TRANSPORTATION**

**STAGING AND TRAFFIC CONTROL PLAN
STAGE 1A
ILLINOIS ROUTE 173**

SCALE: SHEET NO. OF SHEETS STA. 1025+50.00 TO STA. 1040+00.00

F.A.P. RTE.	SECTION	COUNTY	TOTAL SHEETS	SHEET NO.
303	129K-1	WINNEBAGO	401	95
CONTRACT NO. 64987				
FED. ROAD DIST. NO. 2 ILLINOIS FED. AID PROJECT				

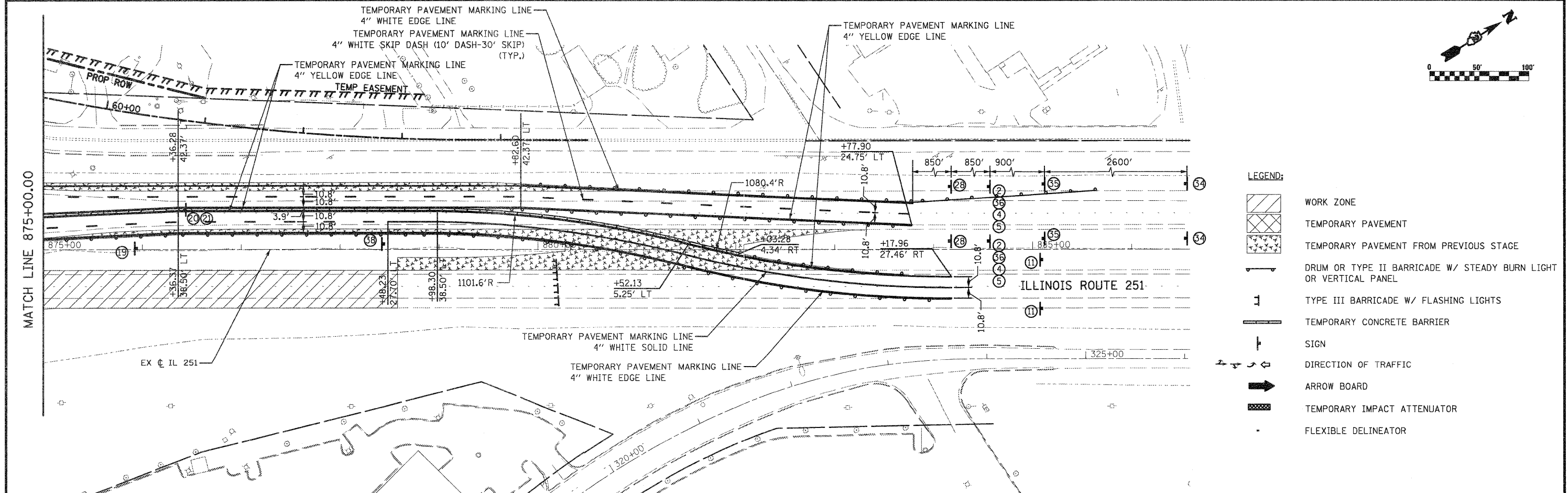
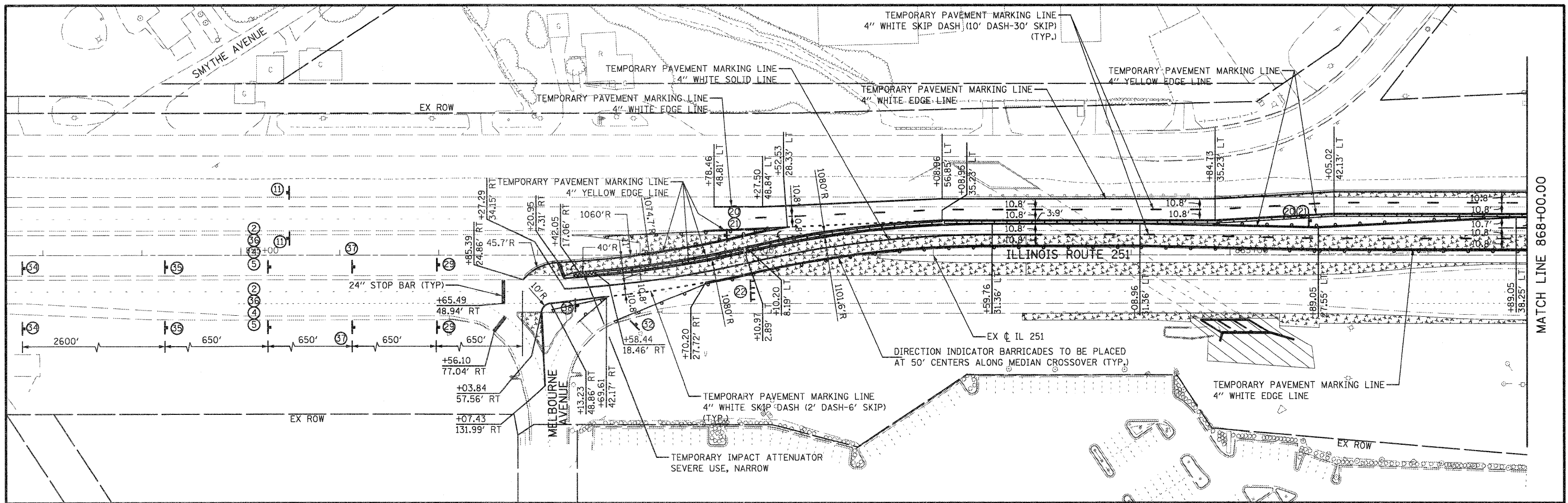

- LEGEND:**
- WORK ZONE
 - TEMPORARY PAVEMENT
 - TEMPORARY PAVEMENT FROM PREVIOUS STAGE
 - DRUM OR TYPE II BARRICADE W/ STEADY BURN LIGHT OR VERTICAL PANEL
 - TYPE III BARRICADE W/ FLASHING LIGHTS
 - TEMPORARY CONCRETE BARRIER
 - SIGN
 - DIRECTION OF TRAFFIC
 - ARROW BOARD
 - TEMPORARY IMPACT ATTENUATOR
 - FLEXIBLE DELINEATOR

FILE NAME = D264987-shl-staging-185.dgn	USER NAME = 3202070971	DESIGNED - LOM	REVISED -	STATE OF ILLINOIS DEPARTMENT OF TRANSPORTATION	STAGING AND TRAFFIC CONTROL PLAN STAGE 1A ILLINOIS ROUTE 251				F.A.P. RTE. 303	SECTION 129K-1	COUNTY WINNEBAGO	TOTAL SHEETS 401	SHEET NO. 96
PLOT SCALE = 100.0000' / IN.		DRAWN - MD	REVISED -		SCALE:	SHEET NO. OF SHEETS	STA. 840+00.00 TO STA. 868+00.00	CONTRACT NO. 64987		FED. ROAD DIST. NO. 2 ILLINOIS FED. AID PROJECT			
PLOT DATE = 1/18/2011		CHECKED - PDK	REVISED -										
		DATE - 01-19-2011	REVISED -										

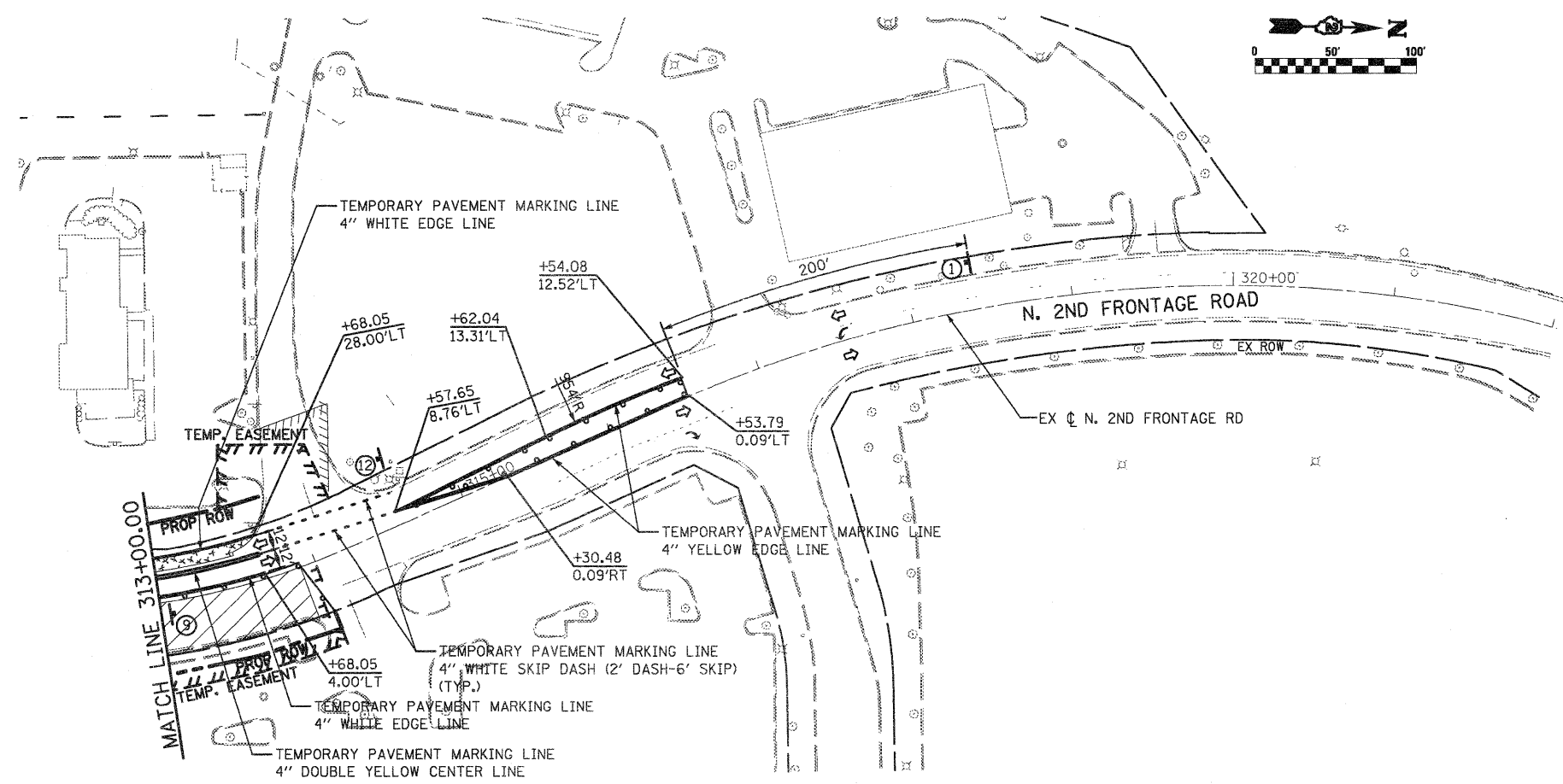
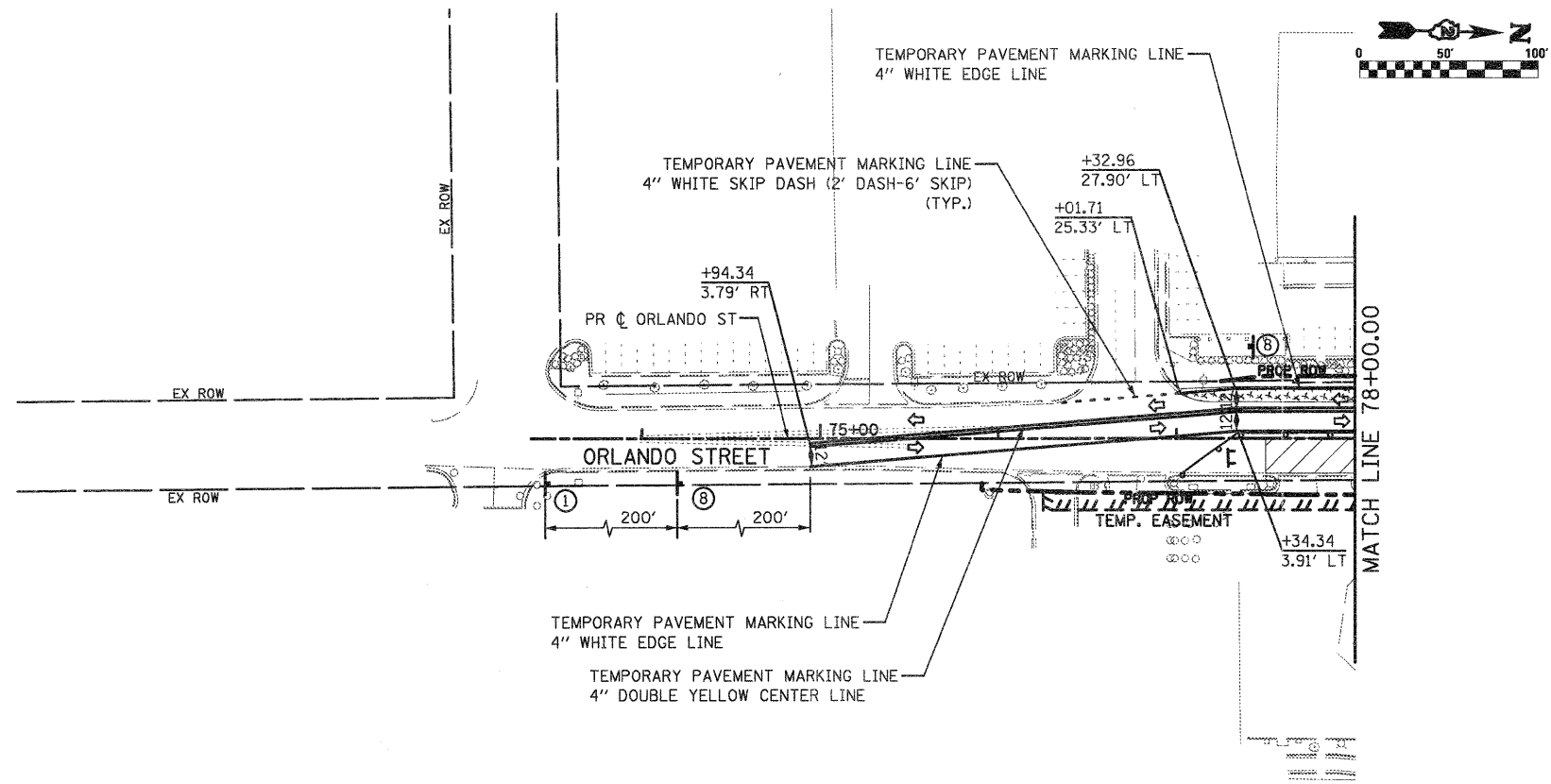

- LEGEND:**
- WORK ZONE
 - TEMPORARY PAVEMENT
 - TEMPORARY PAVEMENT FROM PREVIOUS STAGE
 - DRUM OR TYPE II BARRICADE W/ STEADY BURN LIGHT OR VERTICAL PANEL
 - TYPE III BARRICADE W/ FLASHING LIGHTS
 - TEMPORARY CONCRETE BARRIER
 - SIGN
 - DIRECTION OF TRAFFIC
 - ARROW BOARD
 - TEMPORARY IMPACT ATTENUATOR
 - FLEXIBLE DELINEATOR

FILE NAME = D264987-shr-staging-186.dgn
 USER NAME = 3282890971
 PLOT SCALE = 100.0000' / IN.
 PLOT DATE = 1/18/2011

DESIGNED - LOM
 DRAWN - MD
 CHECKED - PDK
 DATE - 01-19-2011

REVISED -
 REVISED -
 REVISED -
 REVISED -

**STATE OF ILLINOIS
 DEPARTMENT OF TRANSPORTATION**

**STAGING AND TRAFFIC CONTROL PLAN
 STAGE 1A
 ORLANDO ST./N. 2ND FRONTAGE RD.**

SCALE: SHEET NO. OF SHEETS STA. 70+50.00 TO STA. 78+00.00
 STA. 315+00.00 TO STA. 321+50.00

F.A.P. RTE.	SECTION	COUNTY	TOTAL SHEETS	SHEET NO.
303	129K-1	WINNEBAGO	401	97

CONTRACT NO. 64987
 FED. ROAD DIST. NO. 2 ILLINOIS FED. AID PROJECT

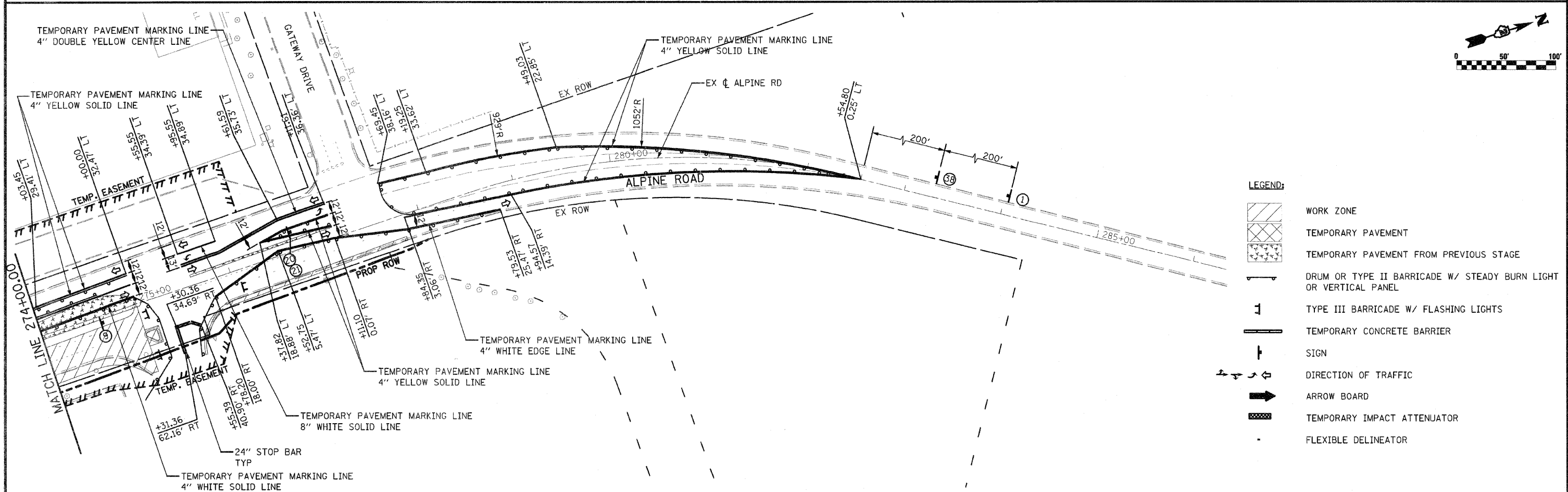
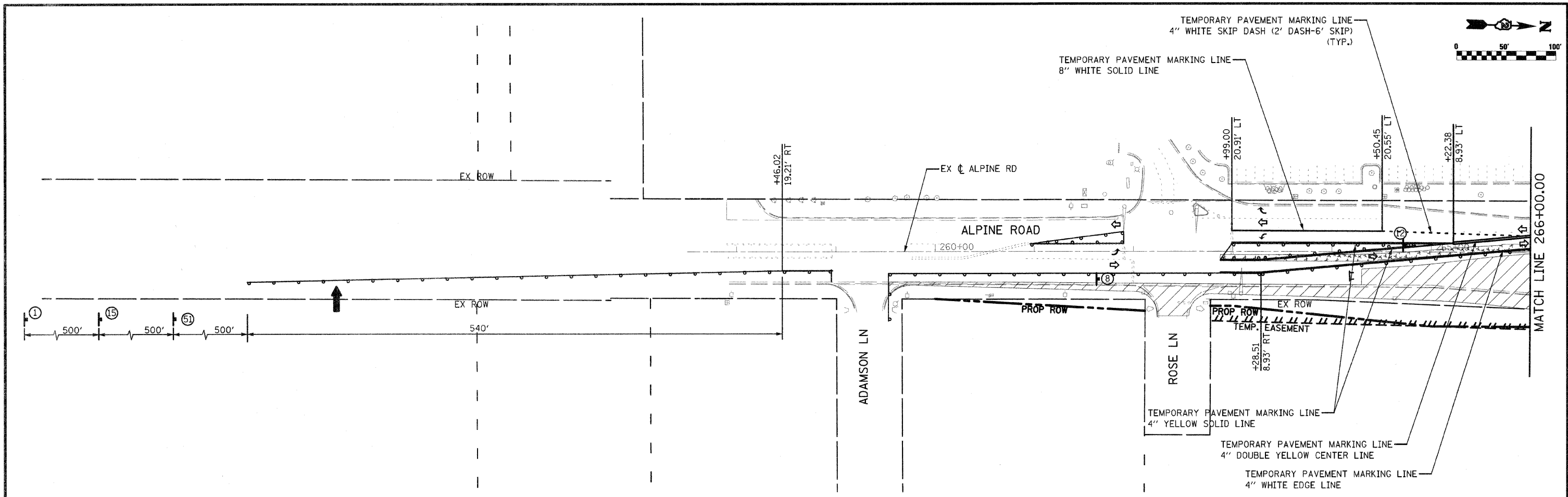

- LEGEND:**
- WORK ZONE
 - TEMPORARY PAVEMENT
 - TEMPORARY PAVEMENT FROM PREVIOUS STAGE
 - DRUM OR TYPE II BARRICADE W/ STEADY BURN LIGHT OR VERTICAL PANEL
 - TYPE III BARRICADE W/ FLASHING LIGHTS
 - TEMPORARY CONCRETE BARRIER
 - SIGN
 - DIRECTION OF TRAFFIC
 - ARROW BOARD
 - TEMPORARY IMPACT ATTENUATOR
 - FLEXIBLE DELINEATOR

FILE NAME = 0264987-sh1-staging-107.dgn

USER NAME = 328289871
 PLOT SCALE = 100.0000' / IN.
 PLOT DATE = 3/16/2011

DESIGNED - LOM
 DRAWN - MD
 CHECKED - PDK
 DATE - 03-16-2011

REVISED -
 REVISED -
 REVISED -
 REVISED -

**STATE OF ILLINOIS
 DEPARTMENT OF TRANSPORTATION**







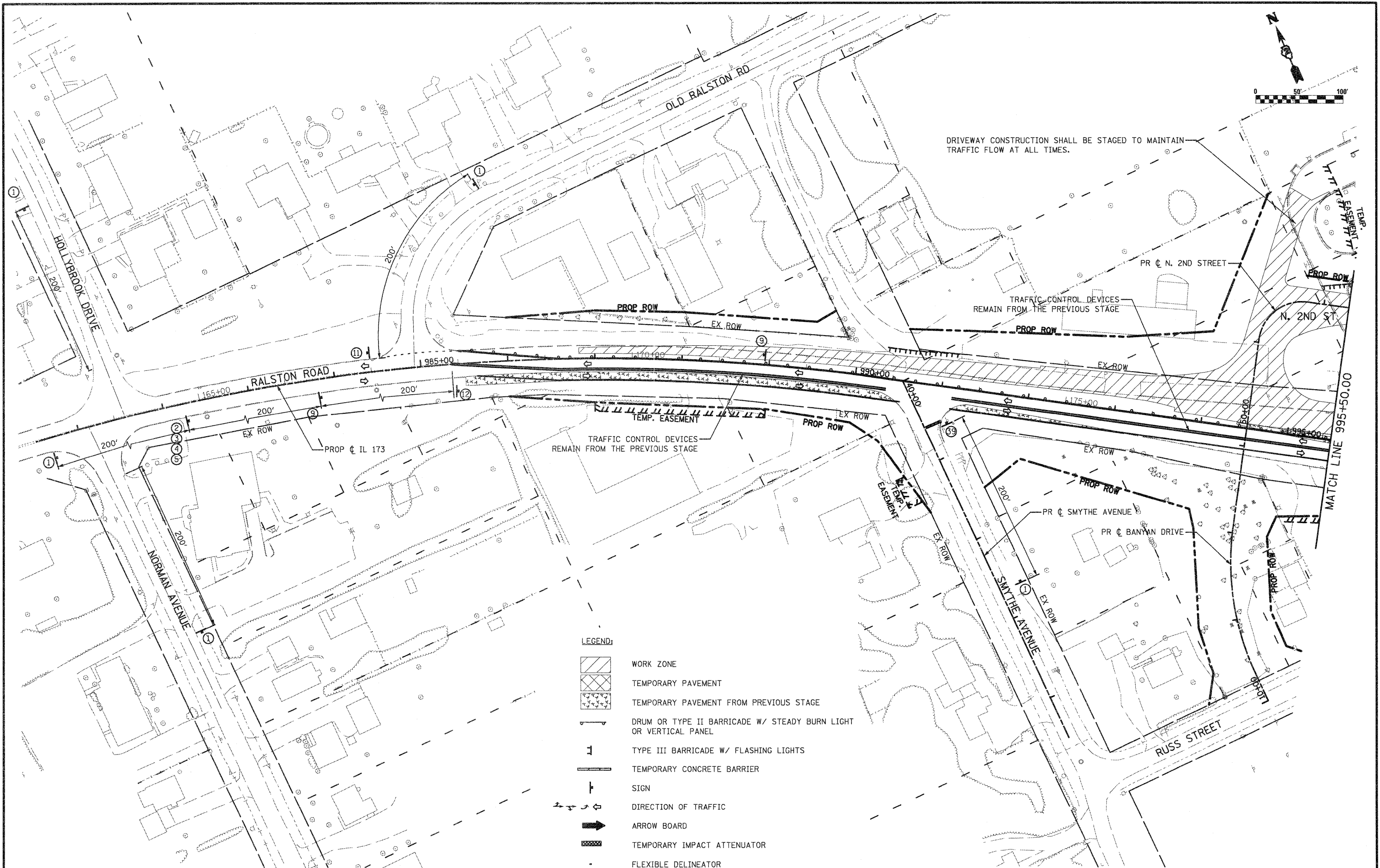



**STAGING AND TRAFFIC CONTROL PLAN
 STAGE 1A
 ALPINE ROAD**

SCALE: SHEET NO. OF SHEETS STA. 251+00.00 TO STA. 289+00.00

F.A.P. RTE.	SECTION	COUNTY	TOTAL SHEETS	SHEET NO.
303	129K-1	WINNEBAGO	401	98
CONTRACT NO. 64987				
FED. ROAD DIST. NO. 2 ILLINOIS FED. AID PROJECT				



DRIVEWAY CONSTRUCTION SHALL BE STAGED TO MAINTAIN TRAFFIC FLOW AT ALL TIMES.

- LEGEND:**
-  WORK ZONE
 -  TEMPORARY PAVEMENT
 -  TEMPORARY PAVEMENT FROM PREVIOUS STAGE
 -  DRUM OR TYPE II BARRICADE W/ STEADY BURN LIGHT OR VERTICAL PANEL
 -  TYPE III BARRICADE W/ FLASHING LIGHTS
 -  TEMPORARY CONCRETE BARRIER
 -  SIGN
 -  DIRECTION OF TRAFFIC
 -  ARROW BOARD
 -  TEMPORARY IMPACT ATTENUATOR
 -  FLEXIBLE DELINEATOR

FILE NAME = D264987-sh1-staging-111.dgn

USER NAME = 3202090971
 PLOT SCALE = 100.0000' / IN.
 PLOT DATE = 1/18/2011

DESIGNED - LOM
 DRAWN - MD
 CHECKED - PDK
 DATE - 01-19-2011

REVISED -
 REVISED -
 REVISED -
 REVISED -

**STATE OF ILLINOIS
 DEPARTMENT OF TRANSPORTATION**

**STAGING AND TRAFFIC CONTROL PLAN
 STAGE 1B
 RALSTON ROAD**

SCALE: SHEET NO. OF SHEETS STA. 980+50.00 TO STA. 995+50.00

F.A.P. RTE.	SECTION	COUNTY	TOTAL SHEETS	SHEET NO.
303	129K-1	WINNEBAGO	401	99
CONTRACT NO. 64987				

FED. ROAD DIST. NO. 2 ILLINOIS FED. AID PROJECT

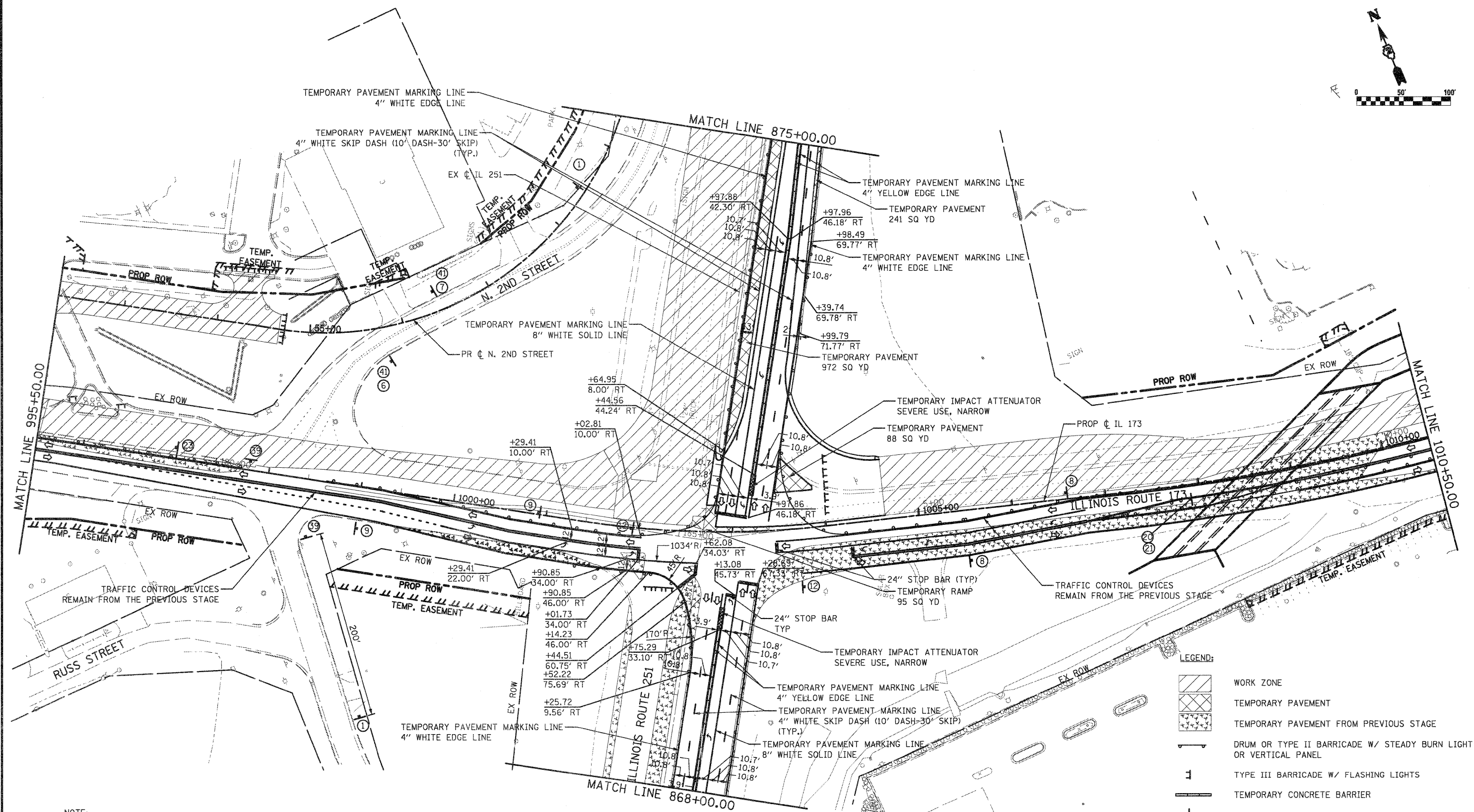
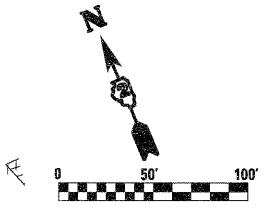

NOTE:
 1. IL 173/N 2ND STREET INTERSECTION WILL BE STAGE CONSTRUCTED TO PROVIDE ACCESS TO TRUCKS AT ALL TIMES. CONSTRUCTION LAYOUT SHALL BE SUBJECT TO THE ENGINEER'S APPROVAL.

- LEGEND:
- WORK ZONE
 - TEMPORARY PAVEMENT
 - TEMPORARY PAVEMENT FROM PREVIOUS STAGE
 - DRUM OR TYPE II BARRICADE W/ STEADY BURN LIGHT OR VERTICAL PANEL
 - TYPE III BARRICADE W/ FLASHING LIGHTS
 - TEMPORARY CONCRETE BARRIER
 - SIGN
 - DIRECTION OF TRAFFIC
 - ARROW BOARD
 - TEMPORARY IMPACT ATTENUATOR
 - FLEXIBLE DELINEATOR

FILE NAME =
 D264987-sh1-staging-112.dgn

USER NAME = 3202090971
 PLOT SCALE = 100.0000' / IN.
 PLOT DATE = 1/18/2011

DESIGNED - LOM
 DRAWN - MD
 CHECKED - PDK
 DATE - 01-19-2011

REVISED -
 REVISED -
 REVISED -
 REVISED -

STATE OF ILLINOIS
 DEPARTMENT OF TRANSPORTATION

STAGING AND TRAFFIC CONTROL PLAN
 STAGE 1B
 RALSTON ROAD/ILLINOIS ROUTE 173

SCALE: SHEET NO. OF SHEETS STA. 995+50.00 TO STA. 1010+50.00

F.A.P. RTE.	SECTION	COUNTY	TOTAL SHEETS	SHEET NO.
303	129K-1	WINNEBAGO	401	100
CONTRACT NO. 64987				

FED. ROAD DIST. NO. 2 ILLINOIS FED. AID PROJECT