

| F.A.P. RTE. | SECTION | COUNTY | TOTAL SHEETS | SHEET NO. |
|---------------------|-----------|------------------|--------------|-----------|
| 310 | 69-3(3HB) | MORGAN | 793 | 66 |
| STA. | | TO STA. | | |
| FED. ROAD DIST. NO. | ILLINOIS | FED. AID PROJECT | | |

3:57:32 PM
Mar-25-2011 03:57:32PM

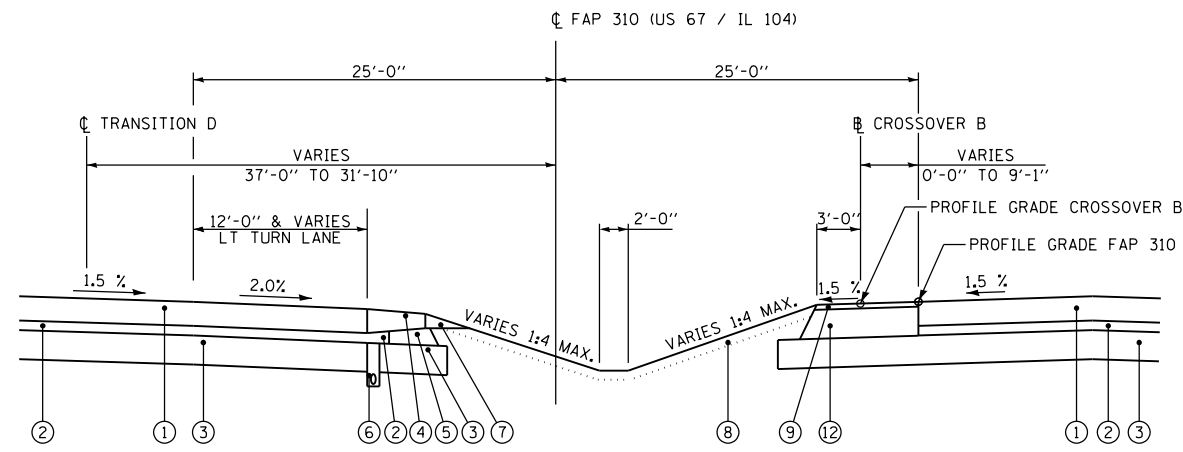

TYPICAL SECTION FAP 310 (US 67/IL 104) WITH CROSSOVER B & TRANSITION D

STA 1126+83.80 TO STA 1130+05.25 FAP 310 STA 15+30.22 TO STA 22+99.37 CROSSOVER B STA 0+00.00 TO STA 3+21.51 TRANSITION D

PROPOSED LEGEND

- ① PORTLAND CEMENT CONCRETE PAVEMENT 10" (JOINTED) - STD 420101
- ② STABILIZED SUB-BASE 4"
- ③ LIME MODIFIED SOIL 12"
- ④ PORTLAND CEMENT CONCRETE SHOULDERS 10" - STD 483001 WITH RUMBLE STRIPS - STD 642001
- ⑤ SUB-BASE GRANULAR MATERIAL, TYPE C
- ⑥ PIPE UNDERDRAINS 6" - STD 601001
- ⑦ AGGREGATE SHOULDERS, TYPE B
- ⑧ TOPSOIL FURNISH AND PLACE, 4"
- ⑨ POLYMERIZED HOT-MIX ASPHALT SURFACE COURSE, MIX "D", N70, 2"
- ⑫ HOT-MIX ASPHALT BASE COURSE, 12" (ANY WIDTH)

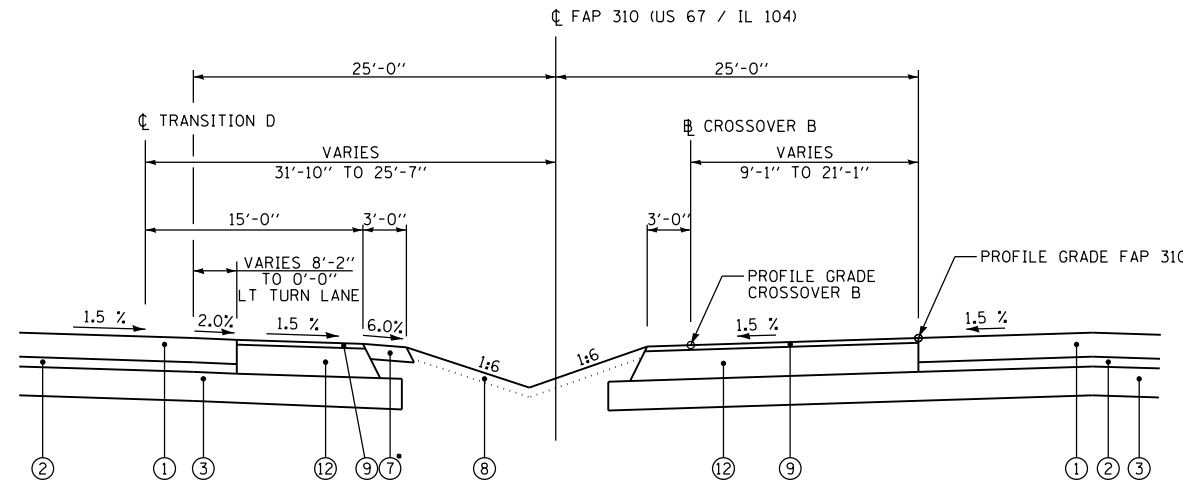

TYPICAL SECTION FAP 310 (US 67/IL 104) WITH CROSSOVER B & TRANSITION D

STA 1130+05.25 TO STA 131+62.23 FAP 310 STA 22+99.37 TO STA 24+56.81 CROSSOVER B STA 3+21.51 TO STA 4+78.61 TRANSITION D

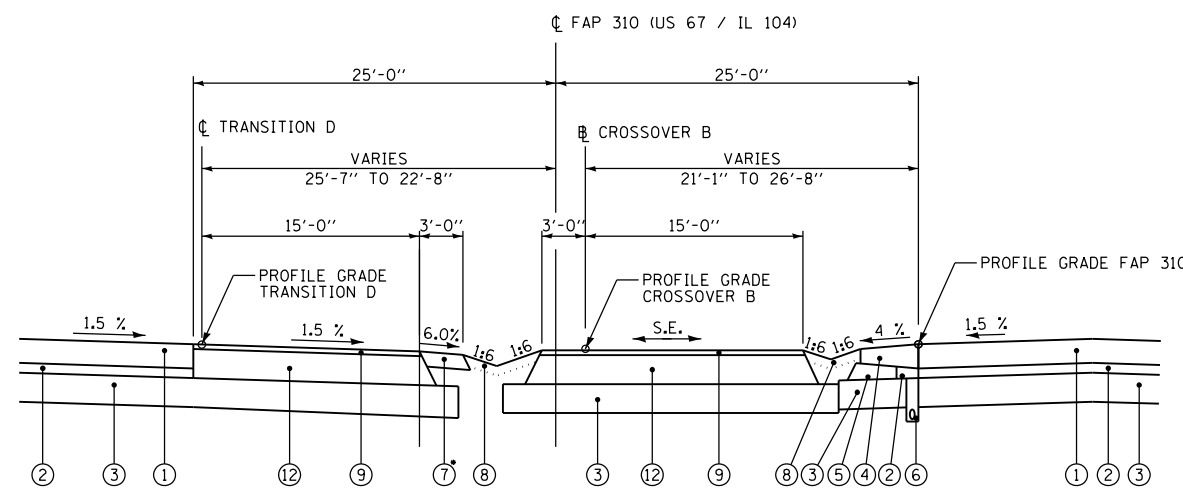

TYPICAL SECTION FAP 310 (US 67/IL 104) WITH CROSSOVER B & TRANSITION D

STA 131+62.23 TO STA 1132+18.86 FAP 310 STA 24+56.81 TO STA 25+13.72 CROSSOVER B STA 4+78.61 TO STA 5+35.31 TRANSITION D

NOTE: NOT TO SCALE

| REVISIONS | |
|-----------|------|
| NAME | DATE |
| | |
| | |
| | |
| | |
| | |
| | |
| | |
| | |
| | |
| | |

ILLINOIS DEPARTMENT OF TRANSPORTATION
TYPICAL SECTIONS
 FAP 310 (US 67/IL 104)
 SHEET 8 OF 24
 DRAWN BY SEB
 CHECKED BY
 DATE 4/2009

\$FILE\$