

# DETAILS OF MAILBOX TURNOUTS

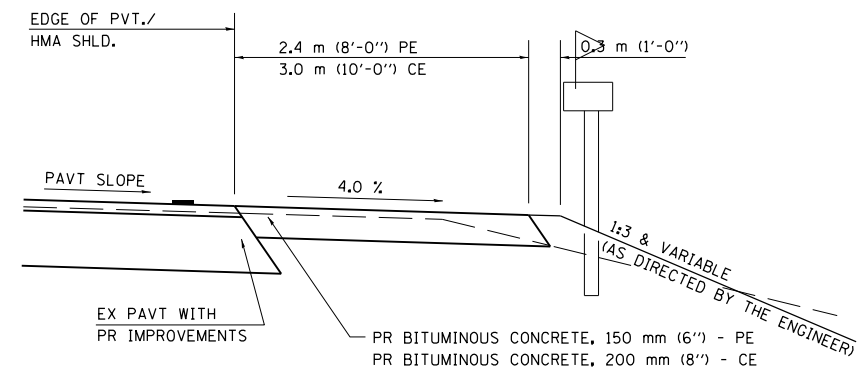
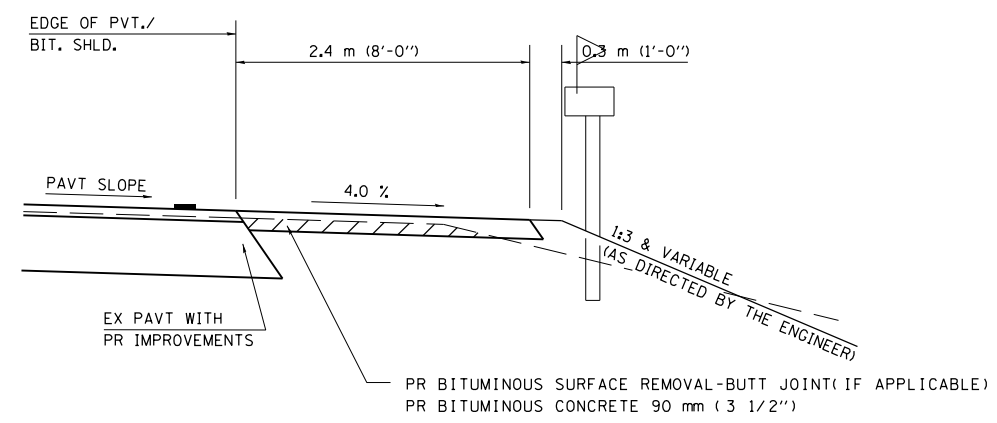
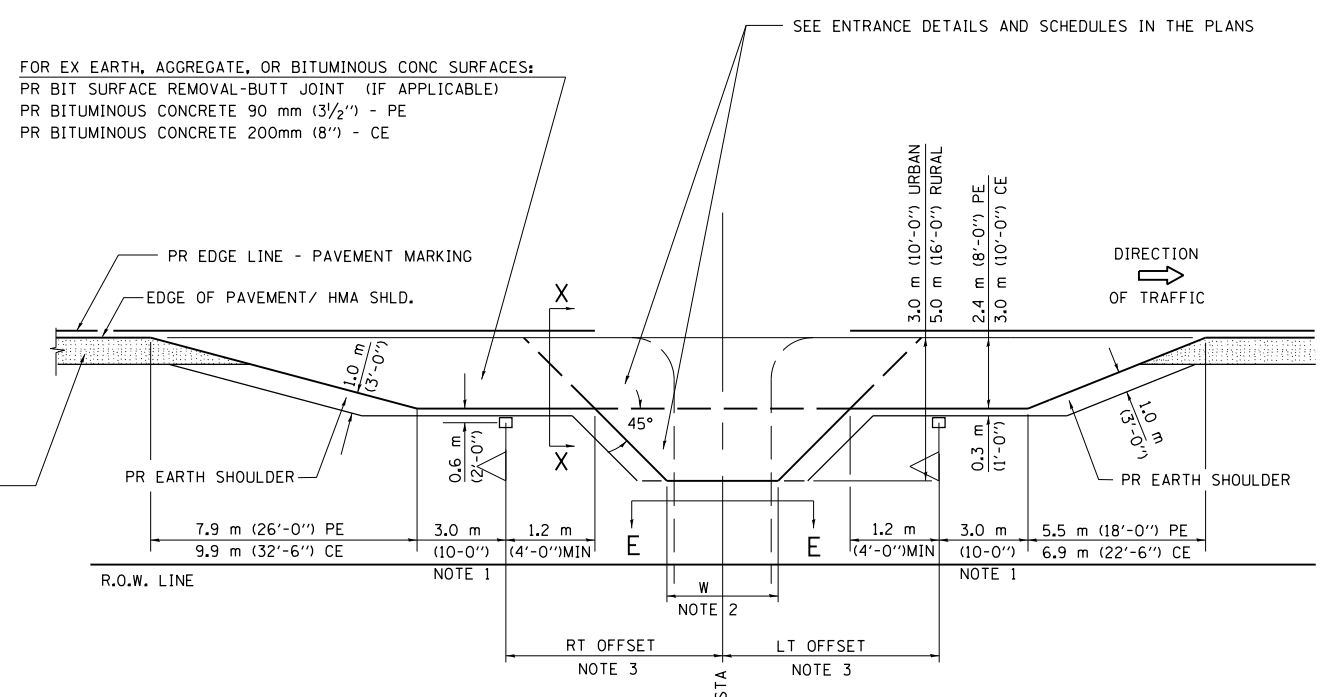
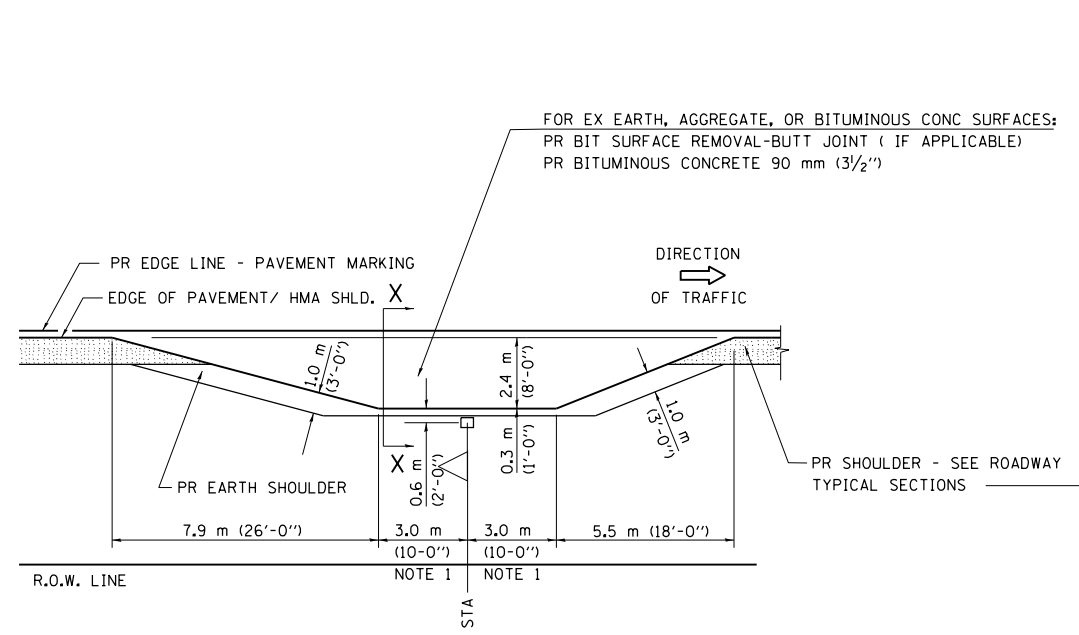

- NOTE 1 IF MORE THAN ONE MAILBOX IS PRESENT, DIMENSION FROM CENTER OF END MAILBOX.
- NOTE 2 FOR ENTRANCE LAYOUT DIMENSIONS AND SECTIONS A-A & E-E REFER TO THE SCHEDULES IN THE PLANS.
- NOTE 3 BOTH LT OR RT OFFSETS FOR MAILBOX SHOWN USE OFFSET DIMENSION PER SCHEDULE AND REFER TO LAYOUT SHOWN ON THE PLAN.

ALL DIMENSIONS ARE IN MILLIMETERS ( INCHES ) UNLESS OTHERWISE SHOWN.

FILE NAME =	USER NAME = Sparksgw	DESIGNED -	REVISED -	<b>STATE OF ILLINOIS DEPARTMENT OF TRANSPORTATION</b>	<b>DIST. 6 DETAILS FOR RURAL/URBAN ENT., MAILBOX TURNOUT &amp; SIDEROADS W/O CONC. GUTTER (3P-PROJ.)</b>	F.A.P. RTE.	SECTION	COUNTY	TOTAL SHEETS	SHEET NO.	
		DRAWN -	REVISED -			714	137 RS-6	MONTGOMERY	16	9	
		CHECKED -	REVISED -			CONTRACT NO. 72E29					
		DATE -	REVISED -			ILLINOIS FED. AID PROJECT					
PLOT SCALE = 40.0000 ' / in.		PLOT DATE = Mar-24-2011 09:10:12AM		SCALE:		SHEET NO. OF SHEETS STA. TO STA.					