

NAVIGATION LIGHT SUPPORT DETAIL
N.T.S.

NOTES:

1. ALL DIMENSIONS ARE IN INCHES UNLESS NOTED OTHERWISE.
2. THE CONTRACTOR SHALL COORDINATE THE NAVIGATION LIGHT ASSEMBLY WITH THE STRUCTURAL STEEL SHOP DRAWINGS. THE CONTRACTOR SHALL SUBMIT SHOP DRAWINGS TO THE ENGINEER FOR APPROVAL OF THE NAVIGATION LIGHT ASSEMBLY.
3. PIPE MOUNTING FLANGE TO HAVE (4) - 3/4" DIA. HOLES.
4. DRILL & PROVIDE EXPANSION ANCHORS. SEE STRUCTURAL DRAWINGS FOR LOCKING ROD SUPPORT AND ANCHORS. LOCATE PLATE RING AND PLATE HOOK 2" FROM TOP SURFACE OF CONCRETE AS INDICATED ON DETAIL.
5. FOR DIMENSIONS OF OTHER STRUCTURAL MEMBERS, REFER TO STRUCTURAL DRAWINGS.
6. TOP OF NAVIGATION LIGHT HOUSING SHALL BE AT THE SAME ELEVATION AS THE BOTTOM OF ADJACENT GIRDER.

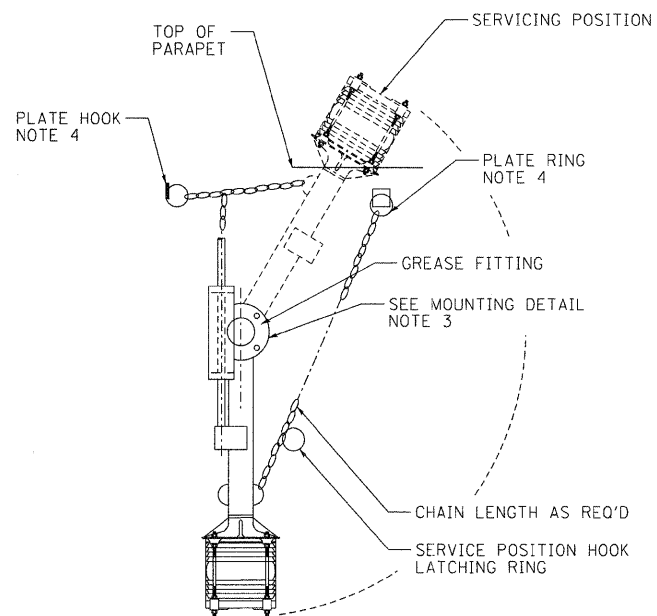

SECTION A-A
NAVIGATION LIGHT FIXTURE
AND SUPPORT ATTACHMENT
N.T.S.

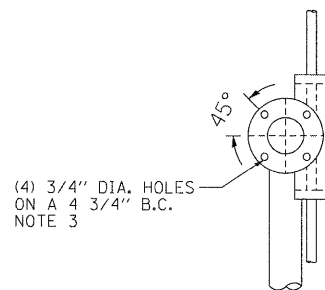

MOUNTING FLANGE DETAIL
N.T.S.

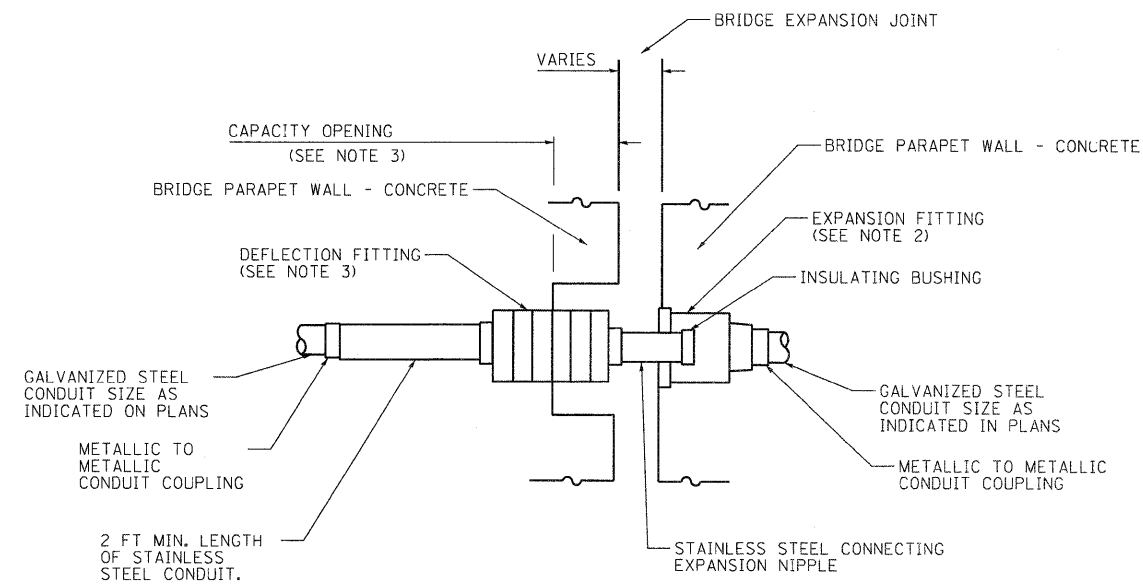

EXISTING CONDUIT EXPANSION / DEFLECTION COUPLING DETAIL

N.T.S.

NOTES:

1. THE CONTRACTOR SHALL INSTALL A CONDUIT EXPANSION / DEFLECTION COUPLING AT THE JOINTS IN THE CONCRETE PARAPET ON THE BRIDGE CAPABLE OF ACCEPTING THE LONGITUDINAL MOVEMENT. THE METALLIC PARTS OF THE COUPLING SHALL BE MADE OF STAINLESS STEEL OR AS APPROVED BY THE ENGINEER. THE COST OF THE COUPLING SHALL BE A PART OF AND INCIDENTAL TO THE CONDUIT SYSTEM.
2. THE BARREL IN THE EXPANSION FITTING SHALL BE FULLY EMBEDDED IN THE CONCRETE ON ONE SIDE OF THE EXPANSION JOINT.
3. ONE HALF OF THE LENGTH OF THE DEFLECTION FITTING SHALL BE EMBEDDED IN THE CONCRETE ON THE OTHER SIDE OF THE EXPANSION JOINT. A CAVITY OPENING 3" LARGER THAN THE DIAMETER OF THE DEFLECTION SLEEVE LENGTH SHALL BE PROVIDED TO ENSURE PROPER PERFORMANCE OF THE COUPLING.
4. CAREFUL ATTENTION TO JOINT MOVEMENT OVER A RANGE OF TEMPERATURES SHALL BE COORDINATED WITH THE SELECTION AND INSTALLATION OF THE COUPLING TO ENSURE THE RANGE OF MOVEMENT OF THE COUPLING IS NOT EXCEEDED AT THE TEMPERATURE EXTREMES.
5. ALL MANUFACTURERS' INSTALLATION INSTRUCTIONS SHALL BE CAREFULLY FOLLOWED TO ENSURE OPTIMUM PERFORMANCE OF THE EXPANSION / DEFLECTION COUPLING.
6. THE CONTRACTOR SHALL INSTALL COUPLINGS AT ALL BRIDGE EXPANSION JOINTS AND SHALL BE RESPONSIBLE TO DETERMINE THE PROPER NUMBER OF COUPLINGS REQUIRED.
7. WITH THE APPROVAL OF THE ENGINEER, THE CONTRACTOR MAY SUBSTITUTE TWO (2) STAINLESS STEEL JUNCTION BOXES ATTACHED TO THE BACK OF THE WALL AND CONNECTED BY A HIGH GRADE OF FLEXIBLE NON-METALLIC CONDUIT FOR ALL EXPANSION JOINTS. THIS SUBSTITUTION SHALL BE MADE AT NO COST TO THE DEPARTMENT.