

**PLAN**

\* Tilt #9 b1(E) bars as required to maintain clearance.

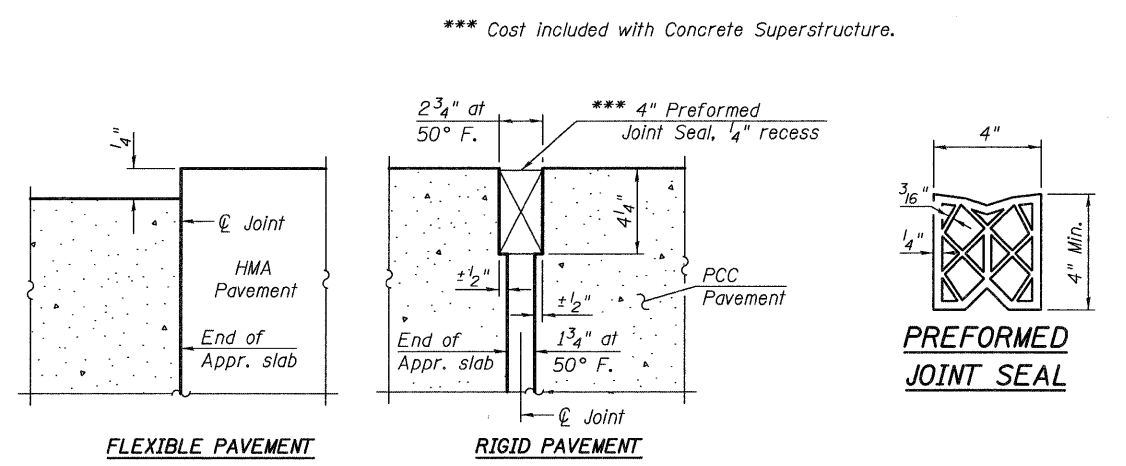

**DETAIL A**

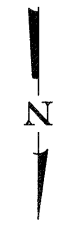
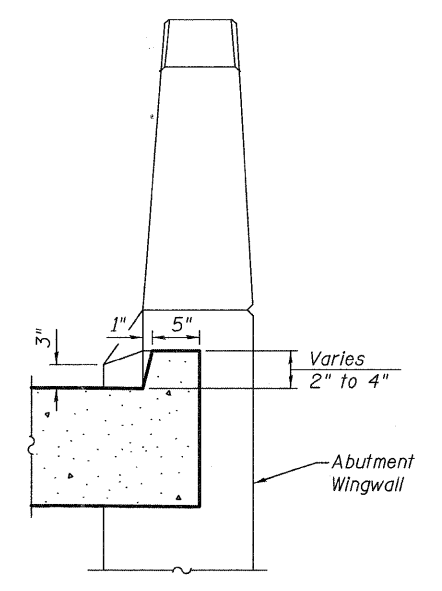

**VIEW B-B**

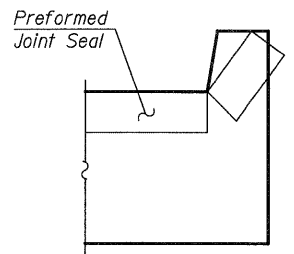

**VIEW F-F**

Angle Preformed Joint Seal at 45° at curbs when req'd for drainage.

**NOTES:**

1. See sheet 42 of 133 for Sections C-C & D-D and View E-E.
2. a(E) and a1(E) bar spacings measured along  $\varnothing$  Rdwy.

3/15/2011 2:15:06 PM ca:\pwworking\oma\0549104\0600345-76A91-041-ASD.dgn jmgus

 HDR ENGINEERING, INC.	USER NAME = jmgus FILE NAME = 0600345-76A91-041-ASD.DGN PLOT SCALE = NONE PLOT DATE = 3/18/2011	DESIGNED - BWC CHECKED - LGP DRAWN - JM CHECKED - BSK	REVISED - REVISED - REVISED - REVISED -	<b>STATE OF ILLINOIS</b> <b>DEPARTMENT OF TRANSPORTATION</b>	<b>WEST BRIDGE APPROACH SLAB DETAILS</b> <b>STRUCTURE NO. 060-0345</b> BRIDGE SHEET NO. 41 OF 133 SHEETS	F.A.I. RTE. 270	SECTION 60-1B-1	COUNTY MADISON	TOTAL SHEETS 712	SHEET NO. 420
	ILLINOIS FED. AID PROJECT						CONTRACT NO. 76A91			