

PLAN

* Tilt #9 b1(E) bars as required to maintain clearance.
 ** Space between a(E) bars, NE parapet only.

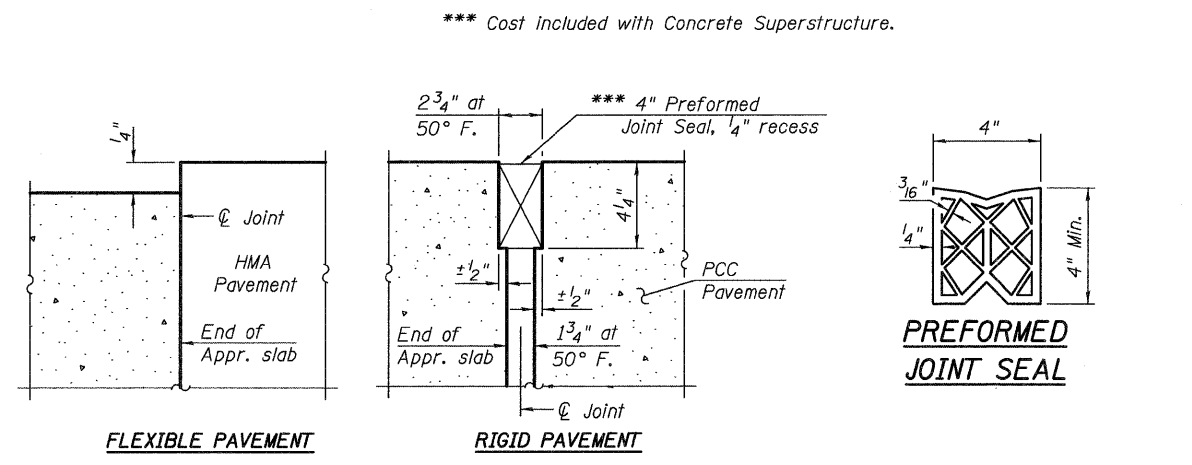

DETAIL A

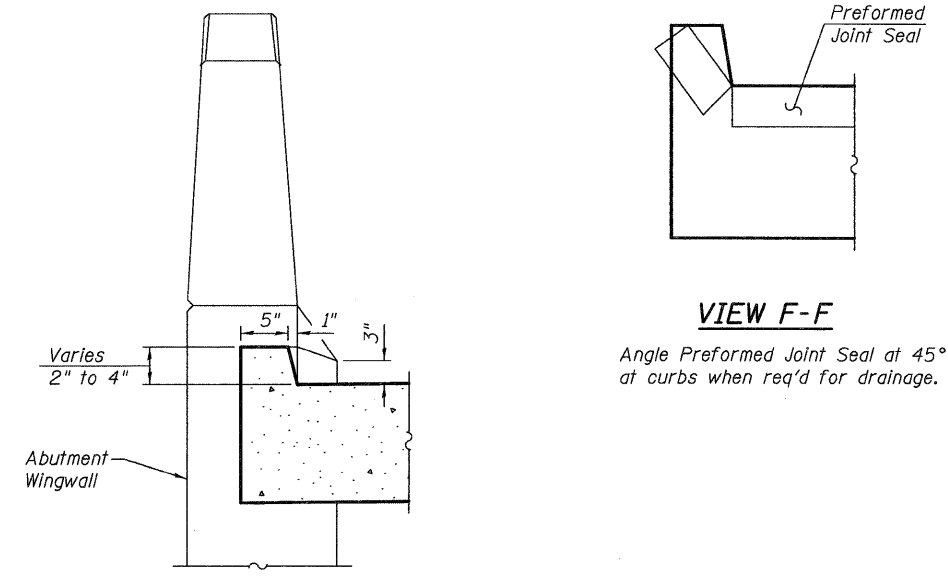

VIEW B-B

NOTES:

1. See sheet 44 of 133 for Sections C-C, D-D & H-H and Views E-E & G-G.
2. a(E) and a1(E) bar spacings measured along \varnothing Rdwy.
3. Cut t(E) and w1(E) bars to fit at corner of approach footing.

c:\pwworking\king\oma\d054904\0600345-76A91-043-ASD.dgn
 jmgus
 3/15/2011 2:15:17 PM



USER NAME = jmgus	DESIGNED - BWC	REVISED -
FILE NAME = 0600345-76A91-043-ASD.DGN	CHECKED - LGP	REVISED -
PLOT SCALE = NONE	DRAWN - JM	REVISED -
PLOT DATE = 3/18/2011	CHECKED - BSK	REVISED -

**STATE OF ILLINOIS
 DEPARTMENT OF TRANSPORTATION**

**EAST BRIDGE APPROACH SLAB DETAILS
 STRUCTURE NO. 060-0345**

BRIDGE SHEET NO. 43 OF 133 SHEETS

F.A.I. RTE.	SECTION	COUNTY	TOTAL SHEETS	SHEET NO.
270	60-1B-1	MADISON	712	422

CONTRACT NO. 76A91
 ILLINOIS FED. AID PROJECT