

STATE OF ILLINOIS
DEPARTMENT OF TRANSPORTATION

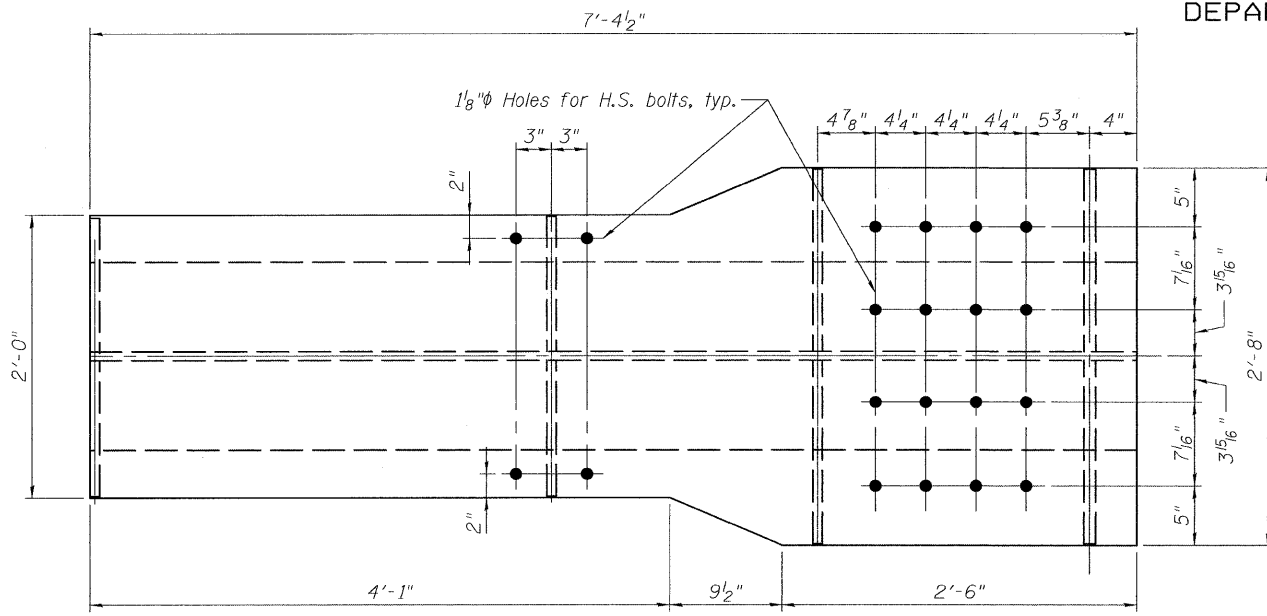

PLAN

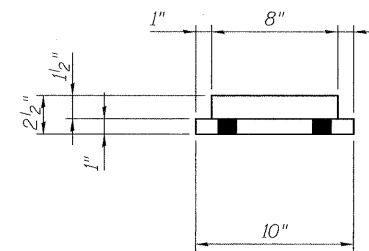

ELEVATION

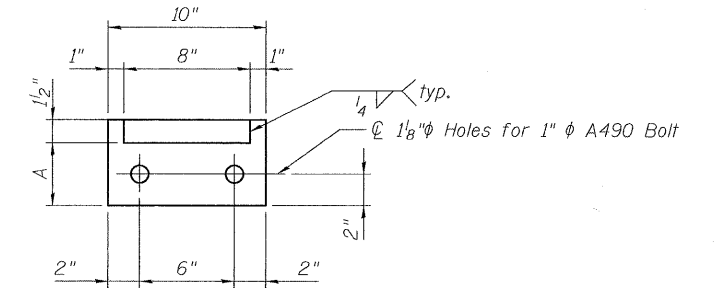

PLAN VIEW

SIDE RETAINER DIMENSIONS	
Pier	A
3	4 3/4"
32	4"
36	4"
40	4 3/4"

SIDE RETAINER
(2 required per catch beam)

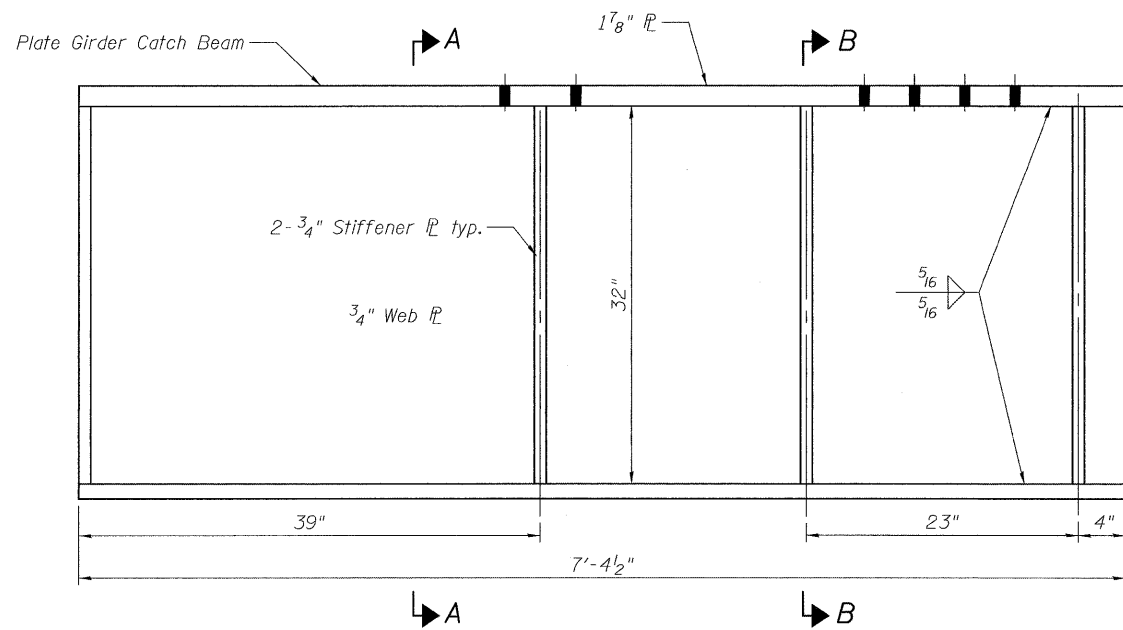

ELEVATION

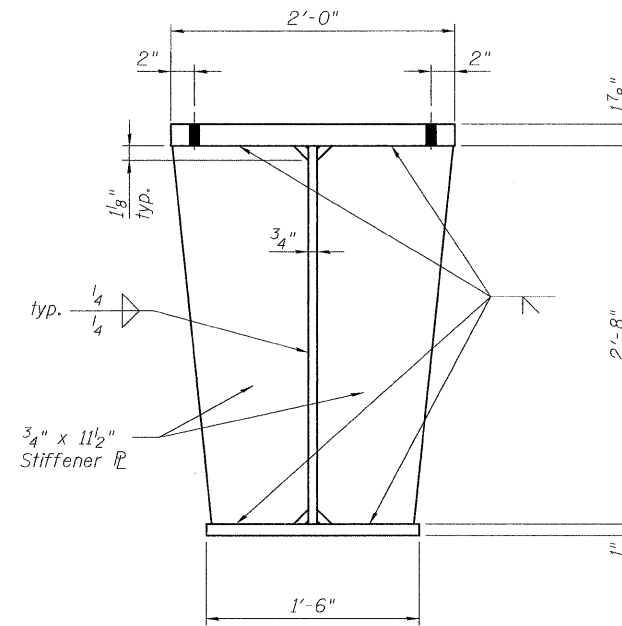

SECTION A-A

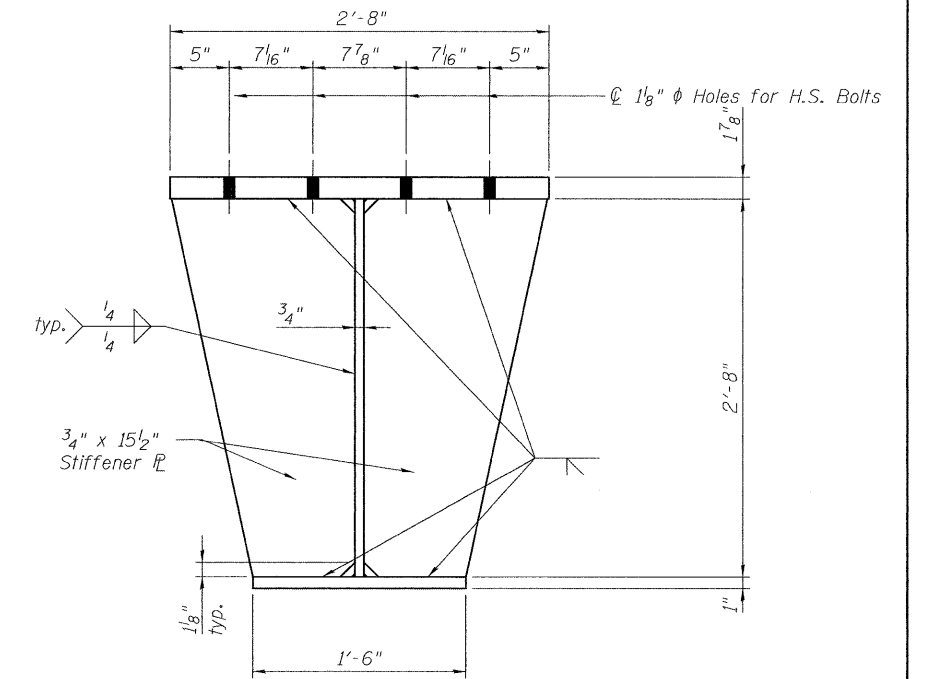

SECTION B-B

CATCH BEAM DETAILS-2
STRUCTURE NO. 060-0035

DESIGNED	TMB
CHECKED	TSB
DRAWN	JGC / TMB
CHECKED	TSB



SHEET NO. 22 36 SHEETS	F.A.I. RTE. 270	SECTION 60B-I-8	COUNTY MADISON	TOTAL SHEETS 49	SHEET NO. 35
	CONTRACT NO. 76A92				
	FED. ROAD DIST. NO. 8 ILLINOIS FED. AID PROJECT				

L:\647178-Cham of Rocks\04 Design\CADD\Sheet Files\0600035-76A92.dgn