

LEGEND

- △ TERMINAL IN MOTOR STARTER
- TERMINAL IN CONTROL PANEL
- ◇ TERMINAL IN SCADA PANEL
- ▲ DEVICE LOCATED ON STARTER DOOR
- DEVICE LOCALLY MTD
- DEVICE IN CONTROL PANEL
- ◆ DEVICE IN SCADA PANEL

NOTES:

1. ALL DEVICES MOUNTED IN MOTOR STARTER UNLESS OTHERWISE NOTED
LINE NO. & WIRE NO. PREFIX "B"
2. NEW MPR FOR EXISTING PUMPS TO BE PROVIDED UNDER NEW CONTRACT.
3. PROVIDE M.C.T. AS SPECIFIED IN SECTION 16D

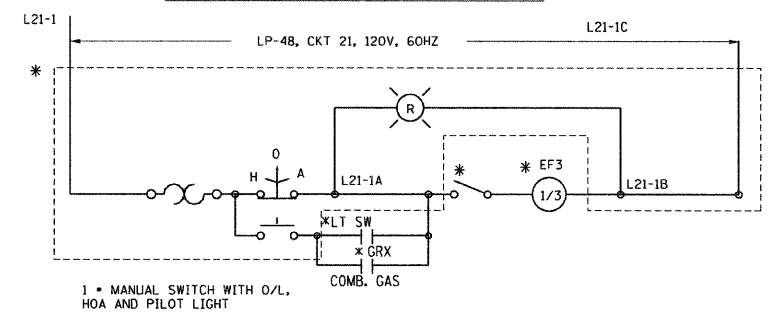
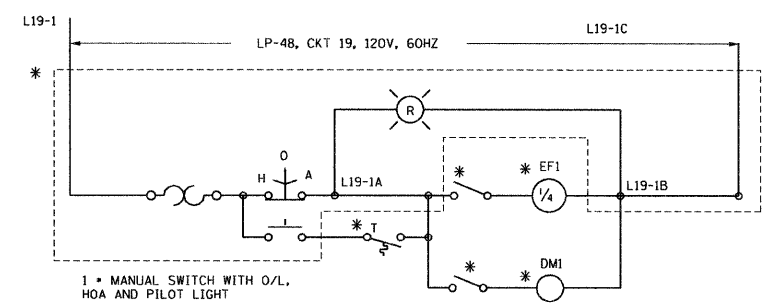
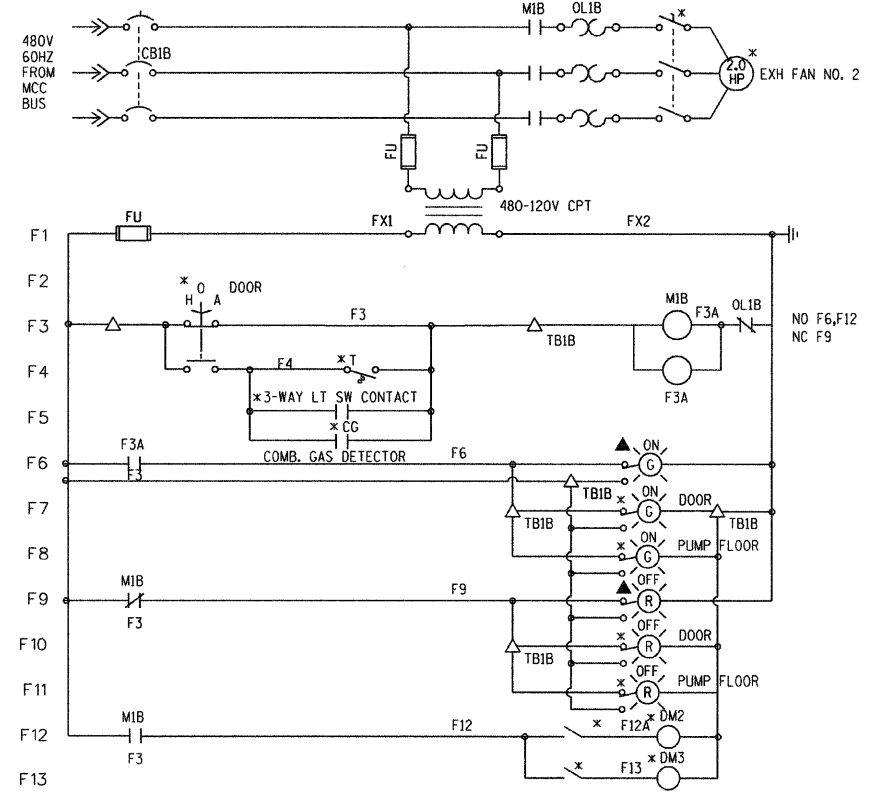
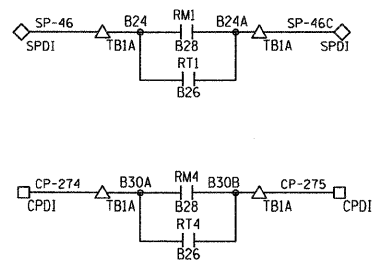

E6

REVISIONS	
NAME	DATE

ILLINOIS DEPARTMENT OF TRANSPORTATION

**PUMP STATION NO. 48
REHABILITATION**

**PUMP AND FAN
CONTROL SCHEMATICS**

SCALE: N/A
DATE: 03-10-11

DRAWN BY: HFF
CHECKED BY: MS

