

ROUTE NO.	SECTION	COUNTY	TOTAL SHEETS	SHEET NO.
FAS1523	*	CHAMPAIGN	38	23
FED. ROAD DIST. NO. 7		ILLINOIS	FED. AID PROJECT-	

\* 09-00956-00-BR  
Contract No. 91452

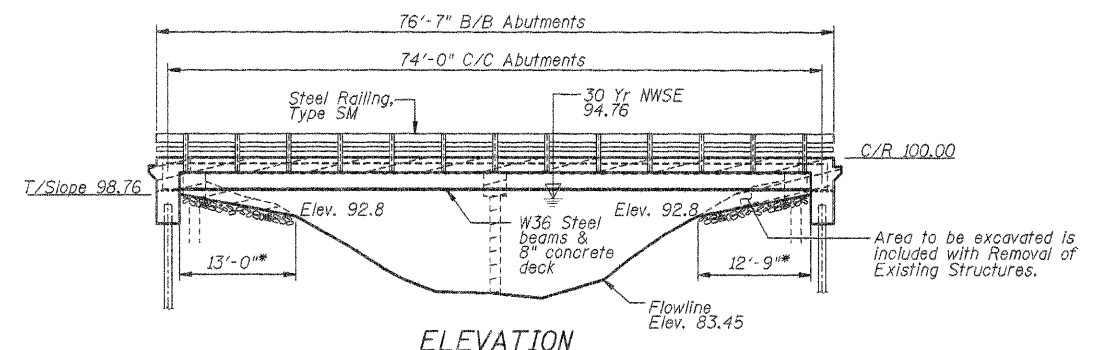

**ELEVATION**  
\* Perpendicular to skew

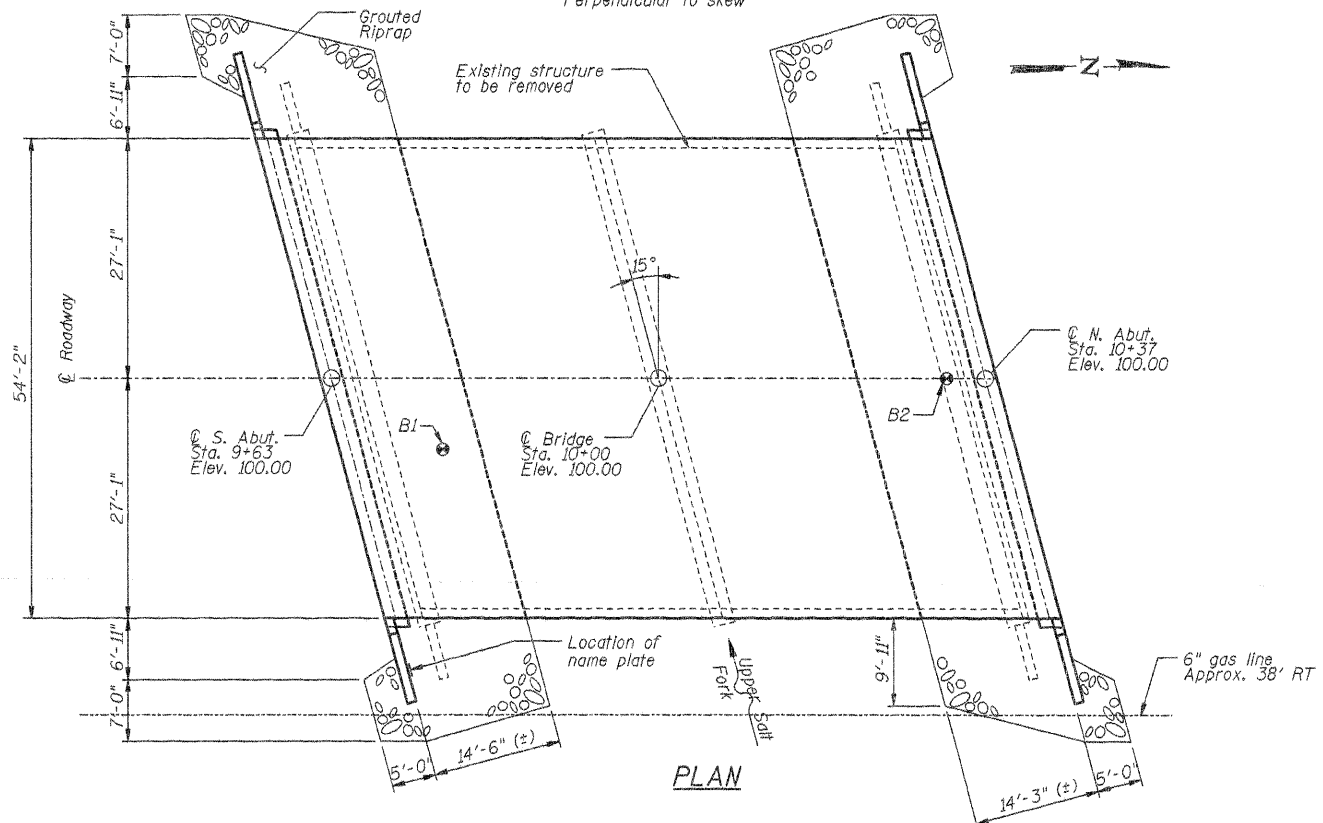

**PLAN**

**BORING DATA**

N - Standard Penetration Test - Blows per foot to drive 2" O.D. split spoon sampler 12" with 140 lb. hammer falling 30".  
 Qu - Unconfined Compressive Strength - Tons/Sq. Ft.  
 W - Water Content - Percentage of oven dry weight - %

**BORING B-1**

Location: STA 9+75.6 (±), 8 ft RT  
Elev. 96.2 (±)

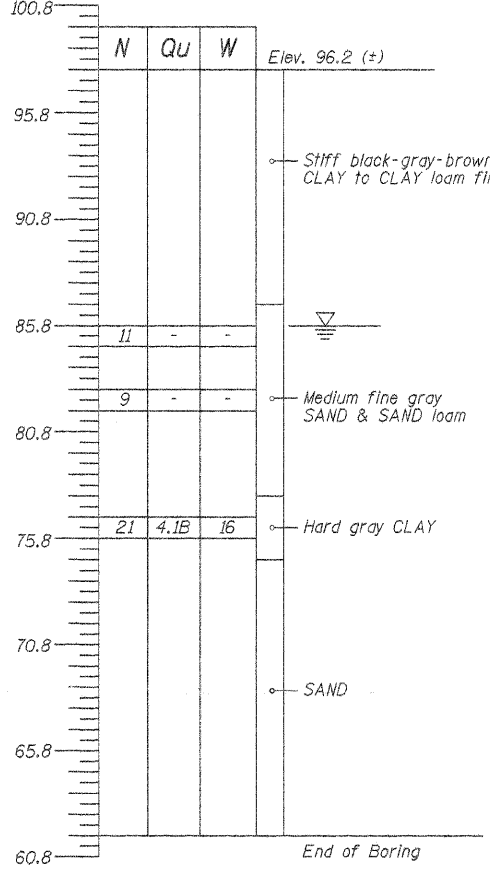

**BORING B-2**

Location: STA 10+32.6 (±), @  
Elev. 97.0 (±)

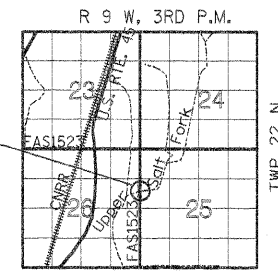
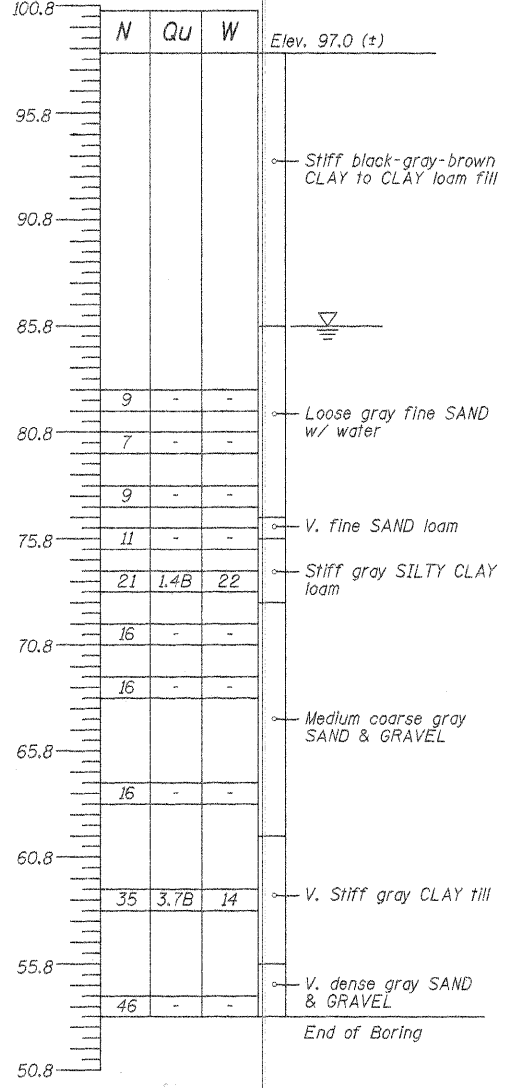

**LOCATION SKETCH**

STRUCTURE NO. 010-4549  
 SEC. 09-00956-00-BR BUILT 20...  
 FAS 1523/CH 55  
 CHAMPAIGN COUNTY  
 LOADING HL 93

**NAME PLATE**

See Standard 515001

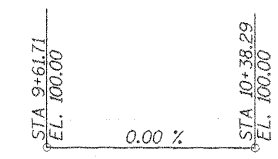

**PROFILE GRADE**

**DESIGN SPECIFICATIONS**

AASHTO LRFD (2007) and applicable Interims

**DESIGN LOADING**

HL-93  
 25 P.S.F Future Wearing Surface

**DESIGN STRESSES**

$f'_c = 3,500$  psi (Cast in Place Concrete)  
 $f_y = 60,000$  psi (M270 Grades 50 & 50W)  
 $f_y = 60,000$  psi (Reinforcement)

**WATERWAY DATA**

Drainage Area	8.2 Sq. Mi.
Existing Opening (30 Yr.)	344 Sq. Ft.
Required Opening (30 Yr.)	313 Sq. Ft.
Proposed Opening (30 Yr.)	374 Sq. Ft.
Design Discharge (30 Yr.)	1610 C.F.S.
Computed Discharge (100 Yr.)	2,160 C.F.S.
30 Year Head	0.02 Ft.
100 Year Head	0.13 Ft.

**TOTAL BILL OF MATERIAL**

ITEM	UNIT	SUPER	SUB	TOTAL
Porous Granular Material (Special)	Cu. Yd.	-	160	160
Removal of Existing Structures	Each	1	-	1
Structure Excavation	Cu. Yd.	-	385	385
Concrete Structures	Cu. Yd.	-	48.5	48.5
Concrete Superstructures (bridge deck)	Cu. Yd.	154	-	154
Bridge Deck Grooving	Sq. Yd.	461	-	461
Protective Coat	Sq. Yd.	490	-	490
Furnishing & Erecting Structural Steel	L. Sum	1	-	1
Reinforcement Bars	Pound	-	2960	2960
Reinforcement Bars, Epoxy Coated	Pound	31770	830	32600
Bar Splicers	Each	108	-	108
Steel Railing, Type SM	Foot	151	-	151
Name Plates	Each	-	1	1
Furnishing Steel Piles HP10x42	Foot	-	1400	1400
Driving Piles	Foot	-	1400	1400
Test Pile Steel HP10x42	Each	-	2	2
Pile Shoes	Each	-	30	30
Geocomposite Wall Drain	Sq. Yds.	-	115	115
Pipe Underdrains For Structures 4"	Foot	-	230	230
Grouted Riprap	Sq. Yds.	-	290	290
Concrete Cut-Off Wall	Cu. Yd.	-	10.8	10.8

**GENERAL NOTES**

- Layout of slope protection system may be varied in the field to suit ground conditions as directed by the Engineer.
- The Contractor shall drive 1 steel test pile in a permanent location at each abutment and each pier as directed by the Engineer before ordering the remainder of piles.
- Boring Data is shown only as as guide to bidders in estimating soil conditions which may be encountered during construction.
- Class SI or MS Concrete shall be used in the abutments and piers.
- Class BS concrete shall be used for the bridge deck.

"I certify that to the best of my knowledge, information and belief, this bridge/box culvert design is structurally adequate for the design loading shown on the plans. The design is an economical one for the style of structure and complies with requirements of the current 'AASHTO Standard Specifications for Highway Bridges'."

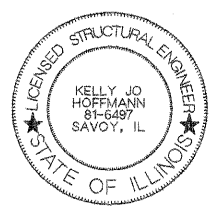

*Kelly Jo Hoffmann*  
 KELLY JO HOFFMANN

Illinois Licensed Structural Engineer Number 6497  
 License Expires 11/30/12

DSGN	K.J. Hoffmann				
DR	B.A. Clark				
CHK	J.R. Wolf				
APVD	J.A. Fraenhoffer	NO.	DATE	REVISION	BY



**FRAUENHOFER & ASSOCIATES**  
 A division of Engineering Resource Associates, Inc.  
 Consulting Engineers, Scientists, & Surveyors

3002 CROSSING COURT  
 CHAMPAIGN, IL 61822  
 PHONE (217) 351-6268  
 FAX (217) 355-1802

**GENERAL PLAN AND ELEVATION**

FAS 1523 (CH 55) OVER UPPER SALT FORK  
 SEC 09-00956-00-BR  
 CHAMPAIGN COUNTY

SHEET	23
DWG NO.	7052GPE.dgn
DATE	FEB 2011
PROJ NO.	7052