

ROUTE NO.	SECTION	COUNTY	SHEET NO.	S-SET NO.
FAS1523	#	CHAMPAIGN	38	33
FED. ROAD DIST. NO. 7		ILL. DIST.	FED. AID PROJECT	

\* 09-00956-00-BR  
Contract No. 91452

TOP OF GIRDER ELEVATIONS

Location	Girder 1		Girder 2		Girder 3		Girder 4		Girder 5	
	Station	Elevation	Station	Elevation	Station	Elevation	Station	Elevation	Station	Elevation
@ bearing S. Abut	9+56.37	98.765	9+57.84	98.880	9+59.32	98.995	9+60.79	99.109	9+62.26	99.224
0.25 L	9+84.62	98.685	9+86.09	98.811	9+87.57	98.926	9+89.04	99.040	9+90.51	99.155
0.50 L	10+12.87	98.653	10+14.34	98.783	10+15.82	98.898	10+17.29	99.012	10+18.76	99.127
0.75 L	10+41.12	98.685	10+42.59	98.811	10+44.07	98.926	10+45.54	99.040	10+47.01	99.155
@ bearing N. Abut	10+30.37	98.765	10+31.84	98.880	10+33.32	98.995	10+34.79	99.109	10+36.26	99.224

Location	Girder 6		Girder 7		Girder 8		Girder 9		Girder 10	
	Station	Elevation	Station	Elevation	Station	Elevation	Station	Elevation	Station	Elevation
@ bearing S. Abut	9+63.74	99.224	9+65.21	99.109	9+66.68	98.995	9+68.16	98.880	9+69.63	98.765
0.25 L	9+91.99	99.155	9+93.46	99.040	9+94.93	98.926	9+96.41	98.811	9+97.88	98.696
0.50 L	10+20.24	99.127	10+21.71	99.012	10+23.18	98.898	10+24.66	98.783	10+26.13	98.668
0.75 L	10+48.49	99.155	10+49.96	99.040	10+51.43	98.926	10+52.91	98.811	10+54.38	98.696
@ bearing N. Abut	10+37.74	99.224	10+39.21	99.109	10+40.68	98.995	10+42.16	98.880	10+43.63	98.765

\* Beam elevation include deflection from weight of concrete only.

INTERIOR GIRDER REACTION TABLE

	(K)	Abut.
R <sub>DC</sub>	29.2	
R <sub>DW</sub>	6.6	
R <sub>L</sub>	54.9	
R <sub>IM</sub>	13.2	
R (Total)	103.9	

EXTERIOR GIRDER REACTION TABLE

	(K)	Abut.
R <sub>DC</sub>	37.3	
R <sub>DW</sub>	6.2	
R <sub>L</sub>	52.0	
R <sub>IM</sub>	12.5	
R (Total)	108	

INTERIOR GIRDER MOMENT TABLE

	(K/ft.)	0.5 Span
I <sub>s</sub>	11300	(in <sup>4</sup> )
S <sub>s</sub>	623	(in <sup>3</sup> )
DC	0.775	(K/ft.)
DW	0.175	(K/ft.)
M <sub>dc</sub>	530	(K)
M <sub>dw</sub>	120	(K)
M (L+IM)	944.2	(K)
M <sub>u</sub> (Strength I)	2495	(K)
f <sub>s</sub> DC	10.22	(k.s.i.)
f <sub>s</sub> DW	2.31	(k.s.i.)
f <sub>s</sub> (L+IM)	18.19	(k.s.i.)
f <sub>s</sub> 1.75(L+IM)	31.83	(k.s.i.)
f <sub>s</sub> (SERVICE II)	36.18	(k.s.i.)
f <sub>s</sub> (Total)(Strength I)	48.07	(k.s.i.)
VR	68.1	(K)

EXTERIOR GIRDER MOMENT TABLE

	(K/ft.)	0.5 Span
I <sub>s</sub>	13200	(in <sup>4</sup> )
S <sub>s</sub>	719	(in <sup>3</sup> )
DC	0.990	(K/ft.)
DW	0.165	(K/ft.)
M <sub>dc</sub>	678	(K)
M <sub>dw</sub>	113	(K)
M (L+IM)	1106.5	(K)
M <sub>u</sub> (Strength I)	2953	(K)
f <sub>s</sub> DC	11.31	(k.s.i.)
f <sub>s</sub> DW	1.88	(k.s.i.)
f <sub>s</sub> (L+IM)	18.47	(k.s.i.)
f <sub>s</sub> 1.75(L+IM)	32.32	(k.s.i.)
f <sub>s</sub> (SERVICE II)	37.20	(k.s.i.)
f <sub>s</sub> (Total)(Strength I)	49.28	(k.s.i.)
VR	64.5	(K)

DEFINITIONS

- I<sub>s</sub>, S<sub>s</sub> : The moment of inertia and section modulus of the steel section used in computing f<sub>s</sub> (Total- Strength I & Service II) due to non-composite dead loads (in<sup>4</sup> and in<sup>3</sup>)
- VR : Maximum un-factored shear range in span.
- DC : Un-factored non-composite dead load (klps/ft.)
- M<sub>dc</sub> : Un-factored moment due to non-composite dead load (k)
- DW : Un-factored long-term composite (superimposed future wearing surface only) dead load (klp/ft.)
- M<sub>dw</sub> : Un-factored moment due to long-term composite (superimposed future wearing surface only) dead load (k)
- M (L+IM) : Un-factored live load moment plus dynamic load allowance (impact) (k)
- M<sub>u</sub> (Strength I) : Factored design moment (k).  
[1.25M<sub>dc</sub> + 1.5M<sub>dw</sub> + 1.75M (L+IM)]
- f<sub>s</sub> (Service II) : Sum of stresses as computed from the moments below (ksi).  
[M<sub>dc</sub> + M<sub>dw</sub> + 1.3M (L+IM)]
- f<sub>s</sub> (Total)(Strength I) : Sum of stresses as computed from the moments below on non compact section (ksi).  
[1.25M<sub>dc</sub> + 1.5M<sub>dw</sub> + 1.75M (L+IM)]

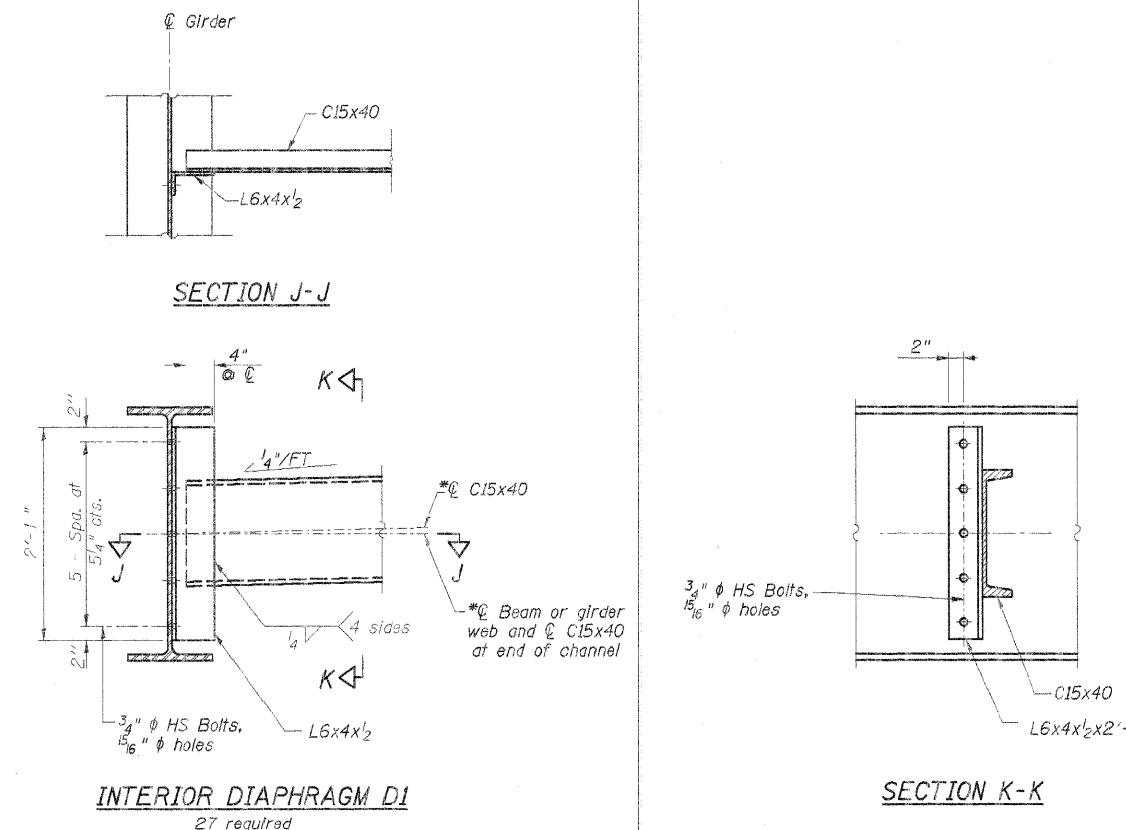

Note:  
Two hardened washers required for each set of oversized holes.  
\*Alternate channels are permitted to facilitate material acquisition. Calculated weight of structural steel is based on the lighter section.  
The alternate, C15x50, if utilized, shall be provided at no additional cost to the Department.

DSGN	K.J. Hoffmann				
DR	N.J. Liggett				
CHK	J.R. Wolf				
APVD	A. Fraenhoffer	NO.	DATE	REVISION	BY

**FRAUENHOFER & ASSOCIATES**  
A division of Engineering Resource Associates, Inc.  
Consulting Engineers, Scientists, & Surveyors

3002 CROSSING COURT  
CHAMPAIGN, IL 61822  
PHONE (217) 351-6268  
FAX (217) 355-3002

STEEL FRAMING DETAILS (SHEET 2 OF 2)		SHEET 33
FAS 1523 (CH 55) OVER UPPER SALT FORK		DWG NO. 7062stl.dgn
SEC 09-00956-00-BR		DATE FEB 2011
CHAMPAIGN COUNTY		PROJ NO. 7052