

F.A. RTE.	SECTION	COUNTY	TOTAL SHEETS	SHEET NO.
CH 7	05-00198-00-BR	MACON	29	1
		ILLINOIS	CONTRACT NO. 95513	

STATE OF ILLINOIS
DEPARTMENT OF TRANSPORTATION

PLANS FOR PROPOSED HIGHWAY BRIDGE PROGRAM

JOB # C-97-063-07

PROJECT # BRM-5169(38)

SECTION 05-00198-00-BR

FAU 7449 (CH 7) OVER FINLEY CREEK

MACON COUNTY

CONTRACT NO. 95513

INDEX OF SHEETS

- 1 COVER SHEET
- 2 GENERAL NOTES AND QUANTITIES
- 3 TYPICAL SECTIONS
- 4 PLAN AND PROFILE
- 5 GRADING PLAN
- 6 TEMPORARY TRAFFIC SIGNALS
- 7-18 BRIDGE PLANS
- 19-29 CROSS SECTIONS

STANDARDS

- 000001-06 STANDARD SYMBOLS, ABBREVIATIONS AND PATTERNS
- 280001-05 TEMPORARY EROSION CONTROL SYSTEMS
- 515001-03 NAME PLATE FOR BRIDGES
- 606001-04 CONCRETE CURB TYPE B AND COMBINATION CONCRETE CURB AND GUTTER
- 630201-06 PCCHMA STABILIZATION AT STEEL PLATE BEAM GUARD RAIL
- 630301-05 SHOULDER WIDENING FOR TYPE 1 (SPECIAL) GUARDRAIL TERMINALS
- 631011-07 TRAFFIC BARRIER TERMINAL, TYPE 2
- 631026-05 TRAFFIC BARRIER TERMINAL, TYPE 5
- 631031-09 TRAFFIC BARRIER TERMINAL, TYPE 6
- 635006-03 REFLECTOR AND TERMINAL MARKER PLACEMENT
- 701006-03 OFF-RD OPERATIONS, 2L, 2W, 15'(4.5m) TO 24'(600mm) FROM PAVEMENT EDGE
- 701301-04 LANE CLOSURE, 2L, 2W SHORT TIME OPERATIONS
- 701701-07 URBAN LANE CLOSURE, MULTILANE INTERSECTION
- 701901-01 TRAFFIC CONTROL DEVICES
- 780001-02 TYPICAL PAVEMENT MARKINGS
- 857001-01 STANDARD PHASE DESIGNATION DIAGRAMS AND PHASE SEQUENCES
- 880001-01 SPAN WIRE MOUNTED SIGNALS AND FLASHING BEACON INSTALLATION
- BLR 21-8 TYPICAL APPLICATION OF TRAFFIC CONTROL DEVICES FOR CONSTRUCTION ON RURAL HIGHWAYS

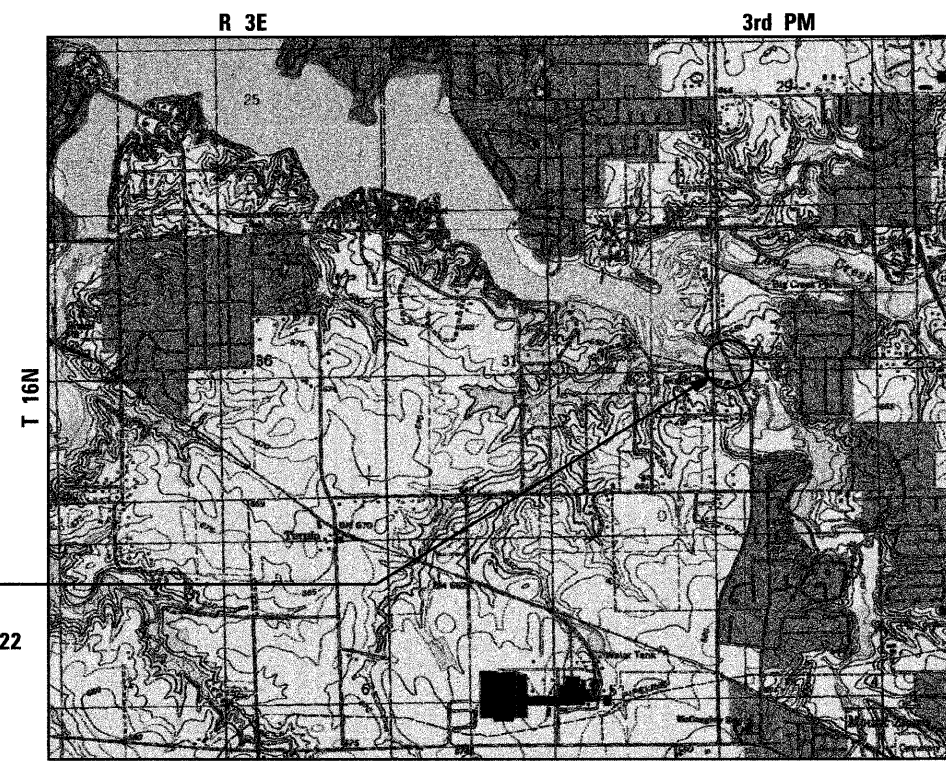
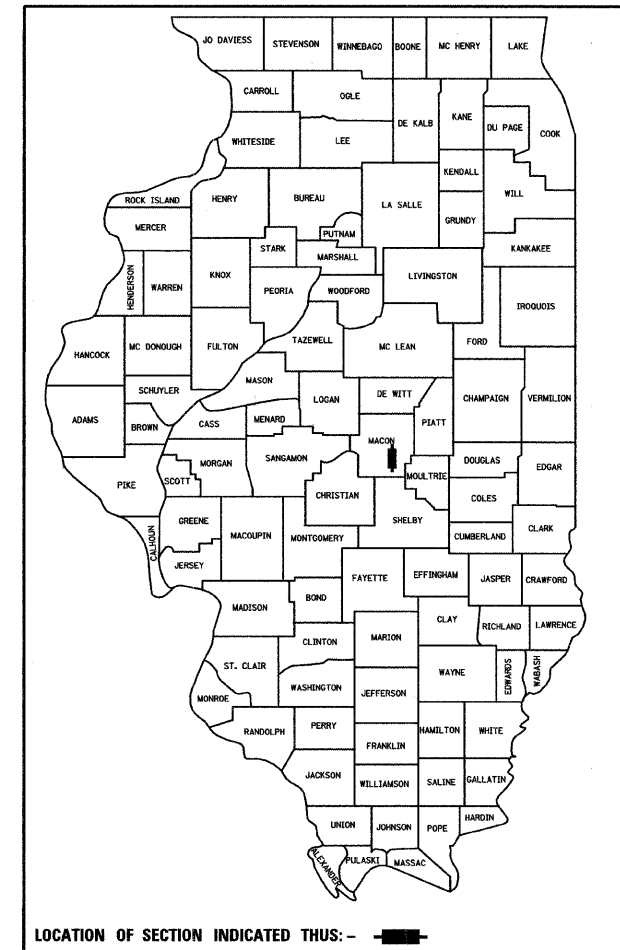

PROPOSED SECTION 05-00198-00-BR
BEGINS STATION 24+05.22
ENDS STATION 28+00
PROPOSED SN 058-3388
EXISTING SN 058-3194

LOCATION MAP

TOTAL LENGTH 394.78 FEET = 0.075 MILES
NET LENGTH 394.78 FEET = 0.075 MILES

THE PROPOSED IMPROVEMENT CONSISTS OF REMOVAL OF EXISTING STRUCTURE AND REPLACEMENT WITH A THREE SPAN PRECAST PRESTRESSED CONCRETE DECK BEAM (17" DEPTH) BRIDGE, PILE BENT PIERS AND ABUTMENTS, 30'-0" CLEAR ROADWAY AND 121'-5 1/2" BACK TO BACK ABUTMENTS, 30 DEGREE SKEW, AND OTHER MINOR COLLATERAL WORK.

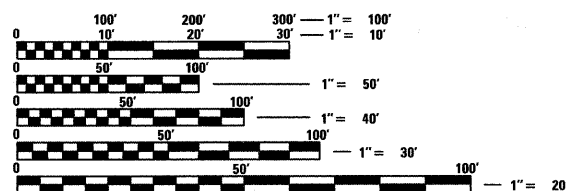

FULL SIZE PLANS HAVE BEEN PREPARED USING STANDARD ENGINEERING SCALES. REDUCED SIZED PLANS WILL NOT CONFORM TO STANDARD SCALES. IN MAKING MEASUREMENTS ON REDUCED PLANS, THE ABOVE SCALES MAY BE USED.

J.U.L.I.E.
JOINT UTILITY LOCATION INFORMATION FOR EXCAVATION
1-800-892-0123

HLC PROJECT NO. 5127
HLC FIELD BOOK NO. 479



Patrick P. Wilson
4/19/11
expires 11/30/11

FUNCTIONAL CLASSIFICATION - MINOR ARTERIAL (URBAN)
2011 ADT = 6800
2031 ADT = 8500
DESIGN SPEED = 45 MPH

APPROVED April 19 2011
Ernie C. ...
COUNTY ENGINEER

PASSED April 25 2011
Maurice ...
DISTRICT SEVEN ENGINEER OF LOCAL ROADS AND STREETS

Releasing For Bid Based on Limited Review April 25 2011
Roger L. ...
DEPUTY DIRECTOR OF HIGHWAYS
REGION FOUR ENGINEER
STATE OF ILLINOIS
DEPARTMENT OF TRANSPORTATION

HOMER L. CHASTAIN & ASSOCIATES, LLP
CONSULTING ENGINEERS
DECATUR (817) 422-8544
CHICAGO (773) 714-0050
ROCKFORD (815) 489-0050
184-001397

SUMMARY OF QUANTITIES

CODE NUMBER	PAY ITEM	UNIT	TOTAL
20200100	EARTH EXCAVATION	CU YD	94
20300100	CHANNEL EXCAVATION	CU YD	640
20400800	FURNISHED EXCAVATION	CU YD	673
28000400	PERIMETER EROSION BARRIER	FOOT	357
28100207	STONE RIPRAP, CLASS A4	TON	556
28200200	FILTER FABRIC	SQ YD	858
30200650	PROCESSING MODIFIED SOIL 12"	SO YD	326
30201700	PORTLAND CEMENT	TON	14
40701801	HOT-MIX ASPHALT PAVEMENT (FULL DEPTH), 6"	SQ YD	314
40701841	HOT-MIX ASPHALT PAVEMENT (FULL DEPTH), 8"	SQ YD	319
44213200	SAW CUTS	FOOT	52
50100100	REMOVAL OF EXISTING STRUCTURES	EACH	1
50200100	STRUCTURE EXCAVATION	CU YD	110
50300225	CONCRETE STRUCTURES	CU YD	89.0
50300255	CONCRETE SUPERSTRUCTURE	CU YD	28.3
50300260	BRIDGE DECK GROOVING	SQ YD	378
50300280	CONCRETE ENCASEMENT	CU YD	30.2
50300300	PROTECTIVE COAT	SO YD	710
50400305	PRECAST PRESTRESSED CONCRETE DECK BEAMS (17" DEPTH)	SQ FT	5748
50800205	REINFORCEMENT BARS, EPOXY COATED	POUND	21700
* 50901750	PARAPET RAILING	FOOT	120
51201400	FURNISHING STEEL PILES HP 10X42	FOOT	1265
51202305	DRIVING PILES	FOOT	1265
51203400	TEST PILE STEEL HP 10X42	EACH	2
51500100	NAME PLATES	EACH	1
59300100	CONTROLLED LOW-STRENGTH MATERIAL	CU YD	74.8
60600605	CONCRETE CURB, TYPE B	FOOT	80
* 63100045	TRAFFIC BARRIER TERMINAL, TYPE 2	EACH	2
* 63100070	TRAFFIC BARRIER TERMINAL, TYPE 5	EACH	2
* 63100085	TRAFFIC BARRIER TERMINAL, TYPE 6	EACH	2
* 63100167	TRAFFIC BARRIER TERMINAL, TYPE 1 (SPECIAL) TANGENT	EACH	2
63200310	GUARDRAIL REMOVAL	FOOT	408
* 63300705	RUB RAIL	FOOT	58
67100100	MOBILIZATION	L SUM	1
70101830	TRAFFIC CONTROL AND PROTECTION, STANDARD BLR 21	L SUM	1
* 78001110	PAINT PAVEMENT MARKING - LINE 4"	FOOT	460
* 78201000	TERMINAL MARKER - DIRECT APPLIED	EACH	4
* 89000100	TEMPORARY TRAFFIC SIGNAL INSTALLATION	EACH	1
X2501000	SEEDING, CLASS 2 (SPECIAL)	ACRE	0.2
X5020501	UNDERWATER STRUCTURE EXCAVATION PROTECTION - LOCATION 1	EACH	1
X5020502	UNDERWATER STRUCTURE EXCAVATION PROTECTION - LOCATION 2	EACH	1
X5030305	CONCRETE WEARING SURFACE, 5"	SQ YD	640
* X5091725	BICYCLE RAILING, SPECIAL	FOOT	140
Z0001900	ASBESTOS BEARING PAD REMOVAL	EACH	40

* SPECIALTY ITEMS

EARTHWORK SCHEDULE

LOCATION	1	2	3	4
	20200100 EARTH EXCAVATION (CU YD)	*EXCAVATION TO BE USED IN EMBANKMENT (ADJUSTED FOR SHRINKAGE) (COL 1 X 0.75) (CU YD)	*EMBANKMENT (FILL) (CU YD)	20400800 FURNISHED EXCAVATION (COL 2 - COL 3) (CU YD)
24+50.00 TO 28+25.00	94	71	744	673

EARTH EXCAVATION SHRINKAGE FACTOR = 25%

ITEMS MARKED WITH AN ASTERISK (*) ARE FOR INFORMATIONAL PURPOSES ONLY

CHANNEL EXCAVATION MAY BE USED AS EMBANKMENT WHEN APPROVED BY THE ENGINEER, BUT IS NOT INCLUDED IN THE EARTHWORK SCHEDULE.

GENERAL NOTES

- All elevations are based on U.S.G.S. Mean Sea Level datum. The proposed grade elevations shown on the plan and profile sheets and station cross sections are the elevations for the finished surface at the locations indicated.
- The following rates were used in calculating quantities for this project:

Riprap: 1.5 Tons / Cu Yd
 Portland Cement: 8% By Weight
 Hot Mix Asphalt: 112 LBS / Sq Yd / Inch

LOCATION(S)	CH 7			
	HOT-MIX ASPHALT PAVEMENT (FULL DEPTH), 8"		HOT-MIX ASPHALT PAVEMENT (FULL DEPTH), 6"	
MIXTURE USE(S)	6" HMA BINDER	2" HMA SURFACE	4" HMA BINDER	2" HMA SURFACE
PG	PG 64-28	PG 64-28	PG 64-28	PG 64-28
DESIGN AIR Voids	4.0 % @ Ndes = 50	4.0 % @ Ndes = 50	4.0 % @ Ndes = 50	4.0 % @ Ndes = 50
MIX COMP (GRADATION)	IL 19.0	IL 9.5	IL 19.0	IL 9.5
FRICTION AGGREGATE	MIX C	MIX C	MIX C	MIX C

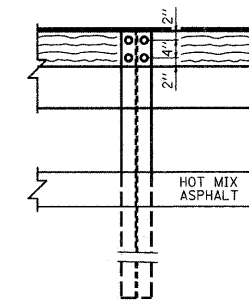

ELEVATION
(BIKE PATH SIDE)

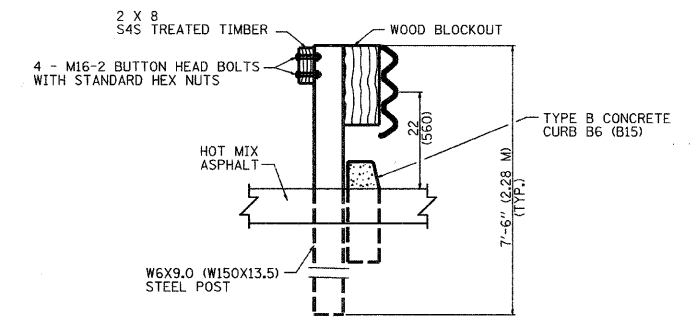

CROSS SECTION

RUBRAIL DETAIL

STA 26+69.81 LT TO STA 27+09.81 RT
 STA 25+31.26 LT TO STA 25+49.26 LT

FILE NAME =	USER NAME = #USER#	DESIGNED -	REVISED -	STATE OF ILLINOIS DEPARTMENT OF TRANSPORTATION	GENERAL NOTES AND QUANTITIES	F.A.U. RTE.	SECTION	COUNTY	TOTAL SHEETS	SHEET NO.	
#FILE#		DRAWN -	REVISED -			7449	05-00198-00-BR	MACON	29	2	
		CHECKED -	REVISED -			CONTRACT NO.		ILLINOIS FED. AID PROJECT			
		PLOT SCALE = #SCALE#		SCALE:	SHEET NO. OF SHEETS	STA.	TO STA.				
		PLOT DATE = #DATE#									

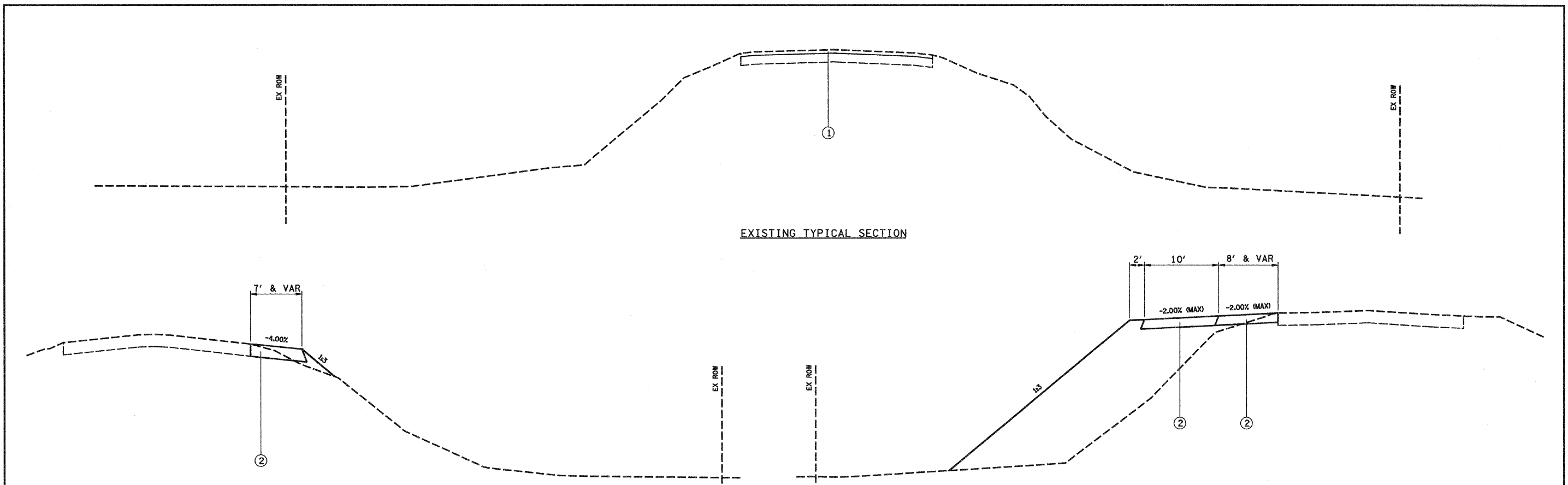

EXISTING TYPICAL SECTION

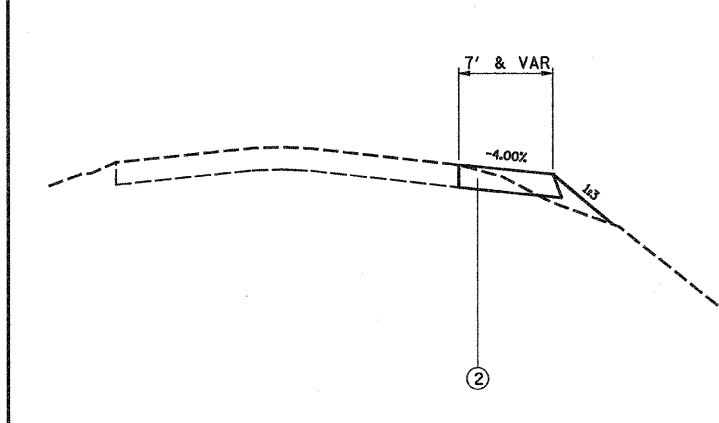

PROPOSED TYPICAL SECTION
STA 24+05.00 TO STA 25+00.00

TRAFFIC BARRIER TERMINAL TYPE 6
AND TYPE 1, SPECIAL (TANGENT)
(N. W. APPROACH)
TRAFFIC BARRIER TERMINAL TYPE 5
AND TYPE 2
(N. E. APPROACH)

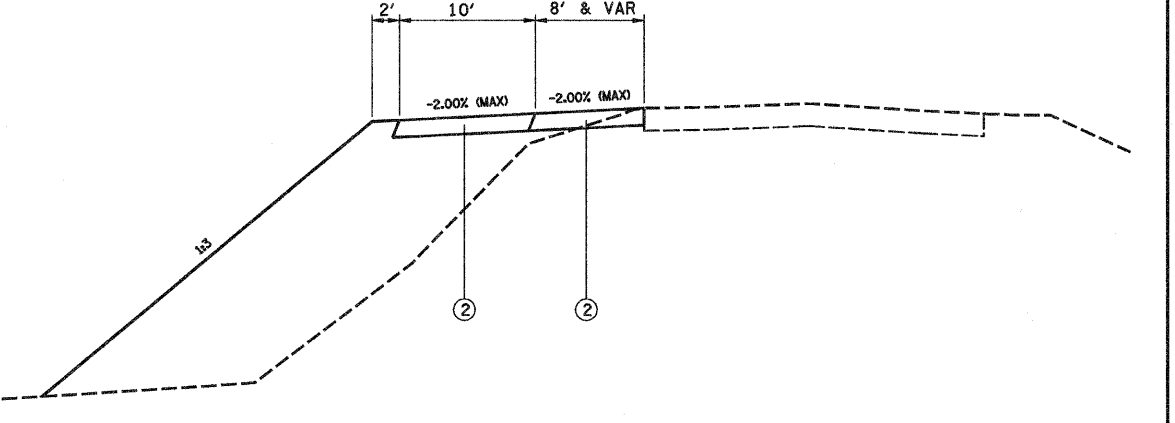

PROPOSED TYPICAL SECTION
STA 27+00.00 TO STA 28+00.00

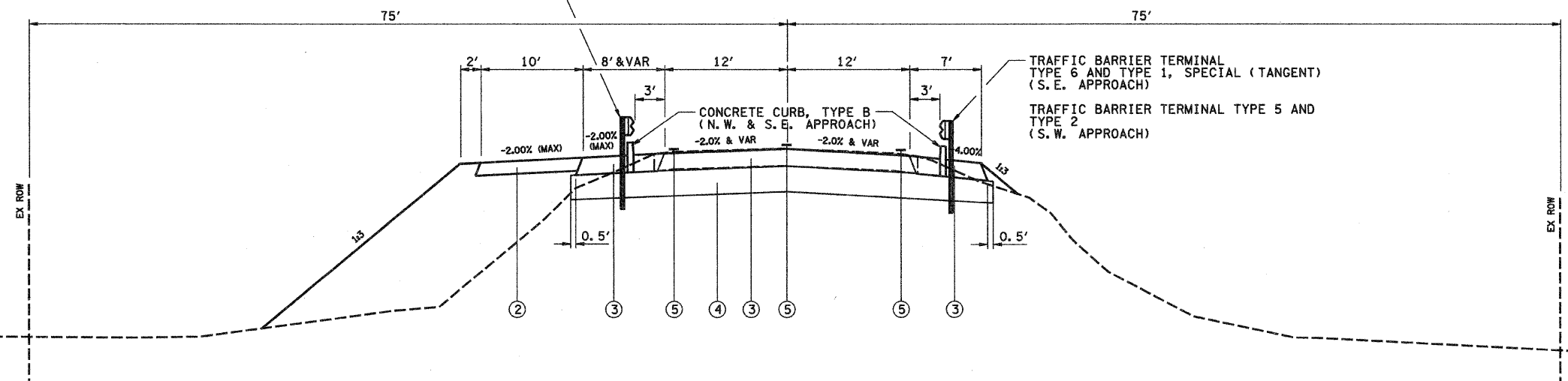

PROPOSED TYPICAL SECTION

STA 25+00.00 TO STA 25+39.47
STA 26+60.91 TO STA 27+00.00

- ① BITUMINOUS SURFACE TREATMENT OVER AGGREGATE BASE COURSE
- ② HOT-MIX-ASPHALT PAVEMENT (FULL DEPTH), 6"
- ③ HOT-MIX-ASPHALT PAVEMENT (FULL DEPTH), 8"
- ④ PROCESSING MODIFIED SOILS, 12"
- ⑤ PAINT PAVEMENT MARKING - LINE 4"

FILE NAME =	USER NAME = rking	DESIGNED -	REVISED -	STATE OF ILLINOIS DEPARTMENT OF TRANSPORTATION	TYPICAL SECTIONS			F.A.U. RTE.	SECTION	COUNTY	TOTAL SHEETS	SHEET NO.
I:\Municipalities\Macon_County\5127 Finle	Creek Bridge\CADD\Civil\gen_notes.dgn	DRAWN -	REVISED -					7449	05-00198-00-BR	MACON	29	3
	PLOT SCALE = 28.0000' / IN.	CHECKED -	REVISED -		CONTRACT NO.			ILLINOIS FED. AID PROJECT				
	PLOT DATE = 4/18/2011	DATE -	REVISED -		SCALE:	SHEET NO.	OF SHEETS	STA.	TO STA.			

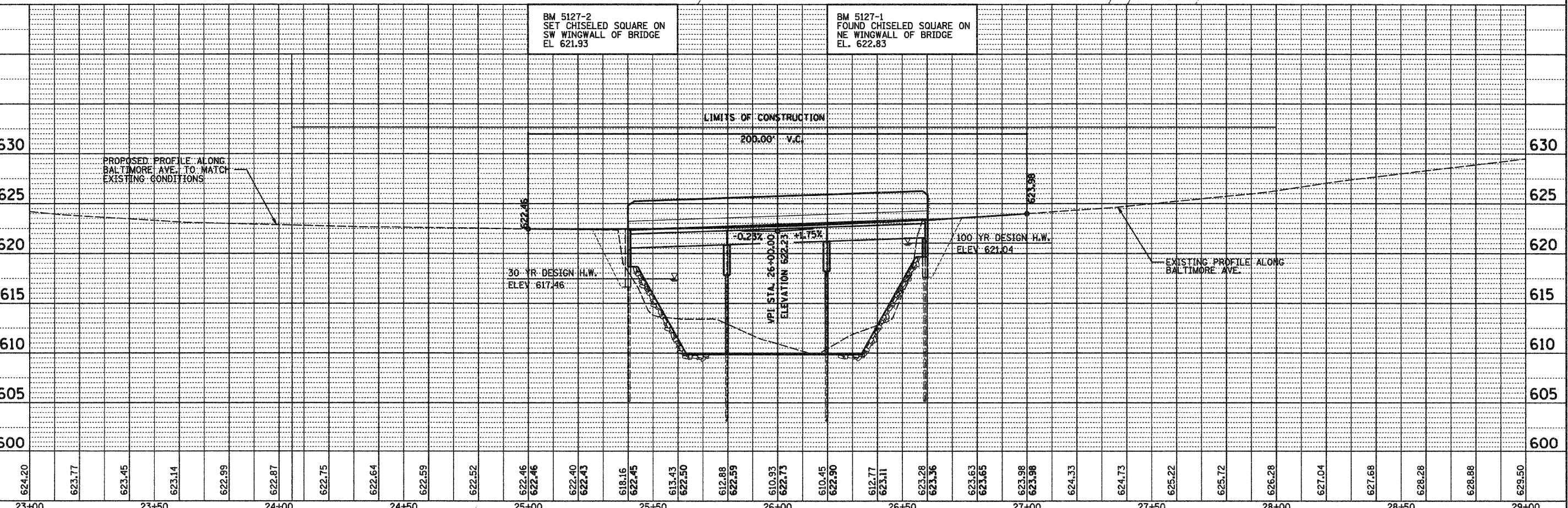
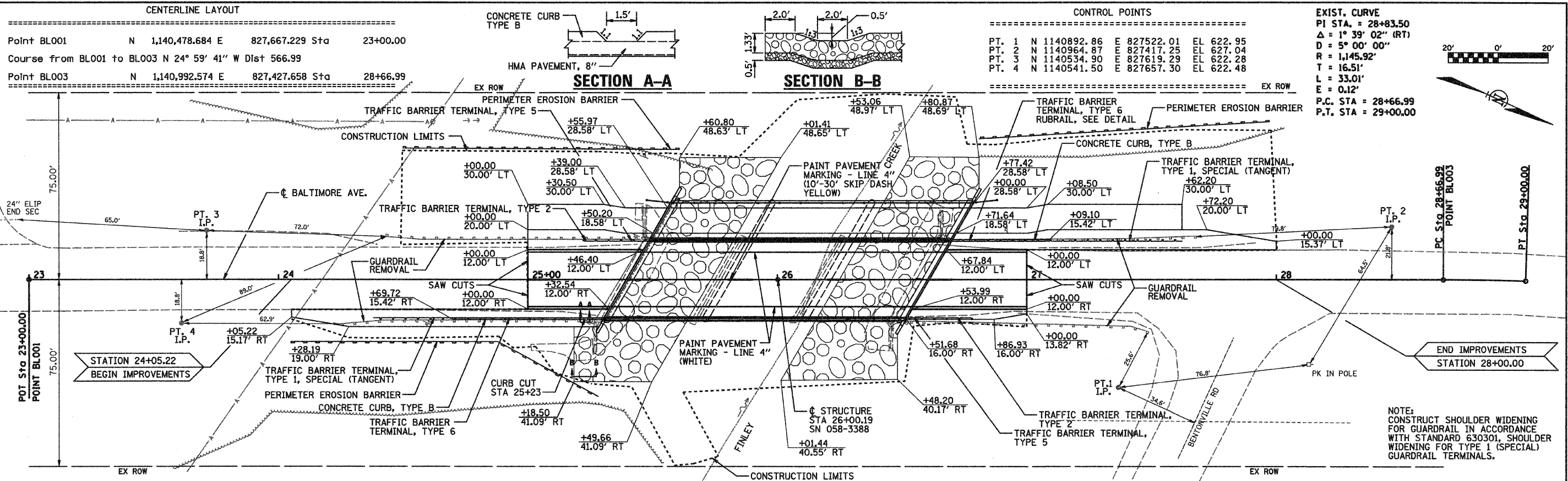

PLAN	SURVEYED	DATE
	PLOTTED	
	CHECKED	
	BY	
	NO. OF WAY CHECKED	
	ROAD FILE NAME	
	NO.	

PROFILE	SURVEYED	DATE
	PLOTTED	
	CHECKED	
	BY	
	NO. OF WAY CHECKED	
	STRUCTURE NOTATION CRD	
	NO.	

FILE NAME =	USER NAME = rking	DESIGNED -	REVISED -	STATE OF ILLINOIS DEPARTMENT OF TRANSPORTATION	PLAN AND PROFILE	F.A.U. RTE.	SECTION	COUNTY	TOTAL SHEETS	SHEET NO.
I:\Municipalities\Macon County\5127 Finley Creek Bridge\CADD\Civil\pp01.dgn	DRAWN -	REVISED -	7449			05-000198-00-BR	MACON	29	4	
PLOT SCALE = 20.0000' / IN.	CHECKED -	REVISED -	CONTRACT NO.			ILLINOIS FED. AID PROJECT				
PLOT DATE = 4/18/2011	DATE -	REVISED -	SCALE:			SHEET NO.	OF SHEETS	STA.	TO STA.	

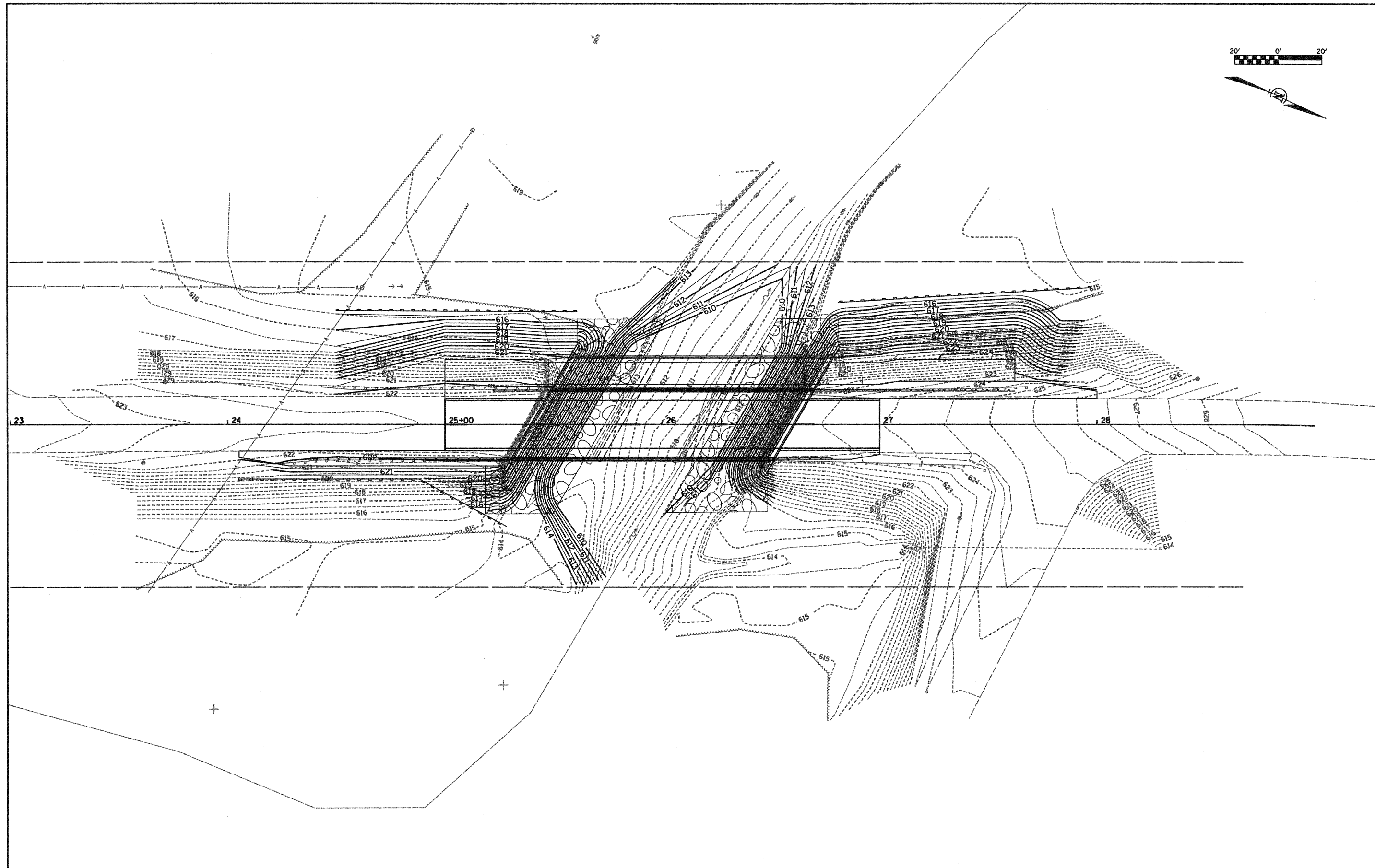
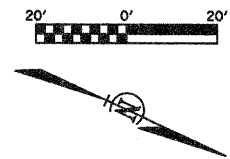

FILE NAME =	USER NAME = rkang	DESIGNED -	REVISED -	STATE OF ILLINOIS DEPARTMENT OF TRANSPORTATION	GRADING PLAN				F.A.J. RTE.	SECTION	COUNTY	TOTAL SHEETS	SHEET NO.
I:\Municipalities\Mecon.County\5127 Finle	Creek Bridge\CADD\Civil\grading_plan.dgn	DRAWN -	REVISED -		7449	05-00198-00-BR	MACON	29	5				
	PLOT SCALE = 20.0000' / IN.	CHECKED -	REVISED -		SCALE: SHEET NO. OF SHEETS STA. TO STA.				CONTRACT NO.				
	PLOT DATE = 4/18/2011	DATE -	REVISED -		ILLINOIS FED. AID PROJECT								

TRAFFIC SIGNAL LEGEND

- SIGNAL HEAD
- + SIGNAL HEAD WITH BACKPLATE
- POST
- ⊥ GUY ANCHOR

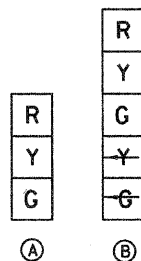

HIGHWAY STANDARDS FOR TRAFFIC SIGNALS

THE FOLLOWING ILLINOIS DEPARTMENT OF TRANSPORTATION HIGHWAY STANDARDS SHALL APPLY TO THIS PROJECT.

- 000001-06 STANDARD SYMBOLS, ABBREVIATIONS AND PATTERNS
- 701006-03 OFF-RD OPERATIONS, 2L, 2W, 15' (4.5m) TO 24' (600mm) FROM PAVEMENT EDGE
- 701301-04 LANE CLOSURE, 2L, 2W SHORT TIME OPERATIONS
- 701701-07 URBAN LANE CLOSURE, MULTILANE INTERSECTION
- 701901-01 TRAFFIC CONTROL DEVICES
- 857001-01 STANDARD PHASE DESIGNATION DIAGRAMS AND PHASE SEQUENCES
- 880001-01 SPAN WIRE MOUNTED SIGNALS AND FLASHING BEACON INSTALLATION

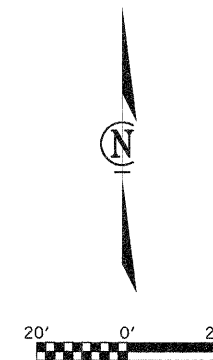

GENERAL NOTES

1. THIS WORK SHALL BE PERFORMED IN ACCORDANCE WITH THE "STANDARD SPECIFICATION FOR ROAD AND BRIDGE CONSTRUCTION", ADOPTED JANUARY 1, 2007, THE LATEST EDITION OF THE "ILLINOIS MANUAL OF UNIFORM TRAFFIC CONTROL DEVICES FOR STREET AND HIGHWAY" AND THE "MANUAL OF TEST PROCEDURES FOR MATERIAL" IN EFFECT ON THE DATE OF INVITATION FOR BIDS, AND THE SUPPLEMENT SPECIFICATION ADOPTED JANUARY 1, 2011. IN THE CASE OF CONFLICT WITH ANY PART OR PARTS OF SAID SPECIFICATIONS, THE SPECIAL PROVISIONS SHALL TAKE PRECEDENCE AND SHALL GOVERN.
2. THE ELECTRICAL WORK SHALL BE IN CONFORMANCE WITH NATIONAL AND LOCAL CODES.
3. THE ACTUAL LOCATION OF ALL SIGNAL POSTS, SIGNAL HEADS, WIRING, TRAFFIC DETECTION AND OTHER APPURTENANCE WILL BE DETERMINED IN THE FIELD BY THE ENGINEER.
4. ALL TRAFFIC SECTIONS SHALL HAVE 12" LENSES.
5. ALL SIGNAL HEADS FURNISHED SHALL HAVE BULBS CAPABLE OF BEING CHANGED BY OPENING THE LENS DOOR AND WITHOUT REMOVING THE REFLECTOR.
6. SIGNALS SHALL BE VIDEO ACTUATED AS DIRECTED BY THE ENGINEER. AT A MINIMUM, THERE SHALL BE VIDEO ACTIVATION ON BENTONVILLE ROAD AND THE LEFT TURN LANES ON IL RTE 121.
7. PLACE "SIGNAL AHEAD" W3-3 SIGNS ON IL RTE 121.
8. NO SURVEY WAS CONDUCTED FOR THE DEVELOPMENT OF THESE PLANS. IT SHALL BE THE CONTRACTOR'S RESPONSIBILITY TO VERIFY ALL UTILITY LOCATIONS PRIOR TO BEGINNING THE WORK.
9. THE BASE LINES WERE ESTABLISHED FOR THE LOCATION PURPOSES FOR THIS PROJECT ONLY. THEY HAVE NO RELATIONSHIP TO PREVIOUS CENTERLINES, LAND LINES, EXISTING RIGHT-OF-WAY, AND UTILITY EASEMENTS.

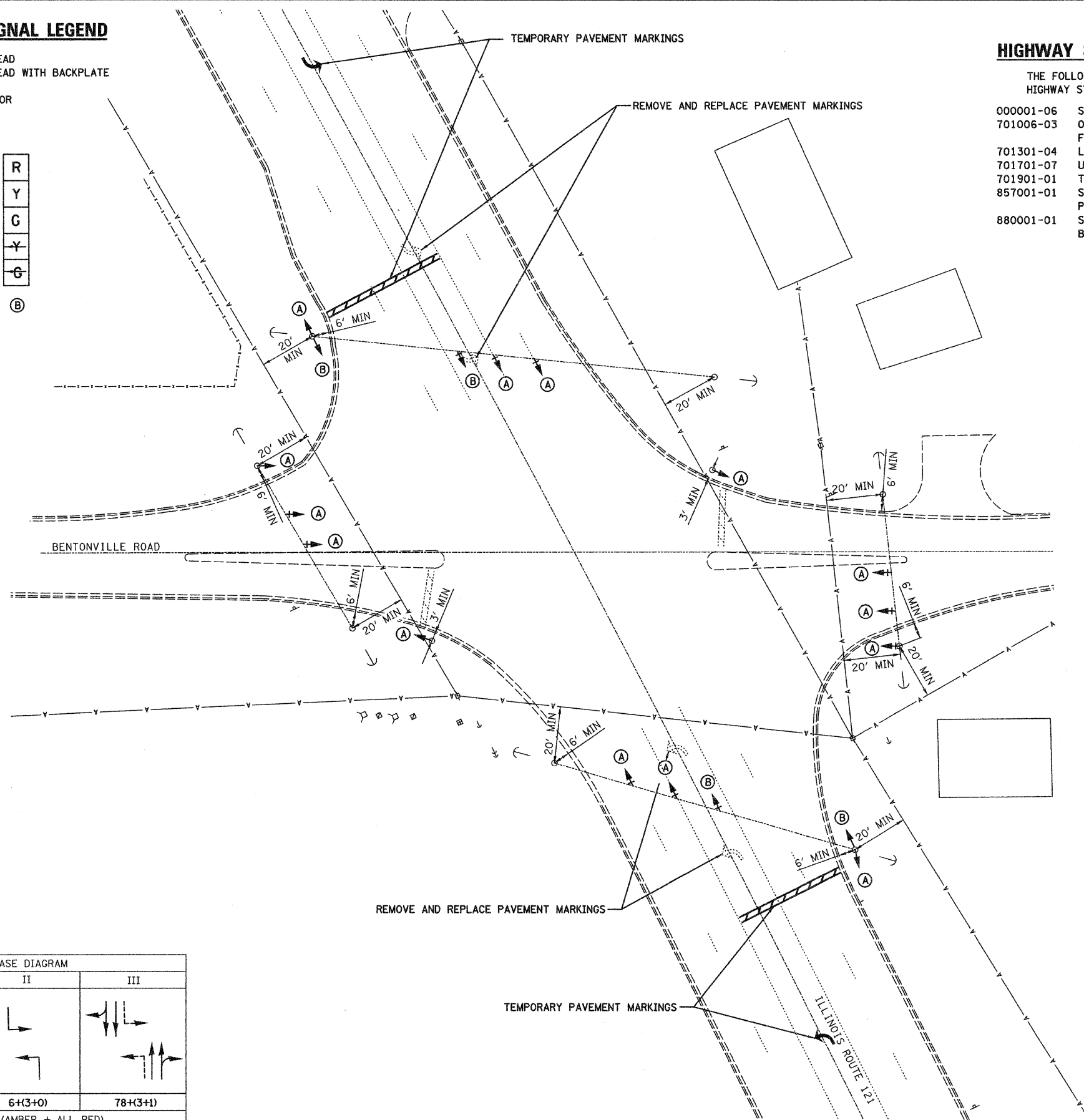

PHASE DIAGRAM		
I	II	III
25+(3+1)	6+(3+0)	78+(3+1)
GREEN + (AMBER + ALL RED)		

FILE NAME = #FILE#	USER NAME = #USER#	DESIGNED -	REVISED -
	PLOT SCALE = #SCALE#	DRAWN -	REVISED -
	PLOT DATE = #DATE#	CHECKED -	REVISED -
		DATE -	REVISED -

**STATE OF ILLINOIS
DEPARTMENT OF TRANSPORTATION**

TEMPORARY TRAFFIC SIGNALS

SCALE: SHEET NO. OF SHEETS STA. TO STA.

F.A.J. RTE.	SECTION	COUNTY	TOTAL SHEETS	SHEET NO.
7449	05-00198-00-BR	MACON	29	6
CONTRACT NO.			ILLINOIS FED. AID PROJECT	

Bench Mark BM 5127-1:
Found chiseled square on
NE wingwall of bridge
Elev 622.83

Bench Mark BM 5127-2:
Set chiseled square on
SW wingwall of bridge
Elev 621.93

Existing Structure:
Three span precast channel deck beams on timber
pile bent abutments and concrete pile bent piers

INDEX OF SHEETS

- 1 General Plan And Elevation
- 2 Deck Plan And Cross Section
- 3-4 Superstructure Details
- 5-6 17"x36" PPC Deck Beam Details
- 7 Bicycle Rail Details
- 8 South Abutment Details
- 9 North Abutment Details
- 10 Pier No. 1 Details
- 11 Pier No. 2 Details
- 12 Steel HP Pile Details

GENERAL NOTES:

For Boring Data see Special Provisions.
Reinforcement bars shall conform to the requirements of
ASTM A706, Grade 60. See Special Provisions.
Layout of the slope protection system may be varied to suit
ground conditions as directed by the Engineer.
All Construction joints shall be bonded.
See Roadway Plans for channel excavation limits and quantities.
See Roadway Plans for additional riprap limits and quantities.
See Roadway Plans for traffic barrier terminal type and location.

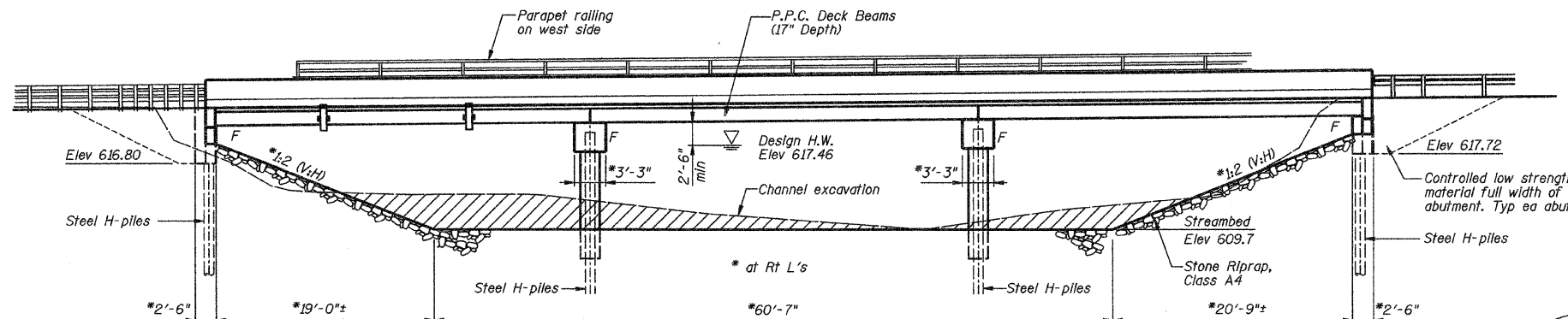

**FINLEY CREEK BRIDGE
BUILT 20 BY
MACON COUNTY
SECTION 05-00198-00-BR
STA 26+00.19
SN 058-3388 LOADING HL93**

LOADING HL 93

Allow 50 lb/sq. ft. for future wearing surface.

DESIGN SPECIFICATIONS

2010 AASHTO LRFD Bridge Design Specifications

DESIGN STRESSES

FIELD UNITS
f'c = 3,500 psi
fy = 60,000 psi (reinforcement)
PRECAST PRESTRESSED UNITS
f'c = 6,000 psi
f'ci = 5,000 psi
f's = 270,000 psi (1/2" φ low relaxation strands)
f'si = 202,000 psi (1/2" φ low relaxation strands)

SEISMIC DATA

Seismic Performance Zone (SPZ) = 1
Design Spectral Acceleration at 1.0 sec. (SD1) = 0.111 g
Design Spectral Acceleration at 0.2 sec. (SDs) = 0.204 s
Soil Site Class = C

TOTAL BILL OF MATERIAL

Item	Unit	Quantity
Removal of Existing Structures	Each	1
Structure Excavation	Cu Yd	110
Concrete Structures	Cu Yd	89.0
Concrete Superstructures	Cu Yd	28.3
Concrete Wearing Surface, 5"	Sq Yd	639.6
Bridge Deck Grooving	Sq Yd	378
Protective Coat	Sq Yd	710
Precast Prestressed Concrete Deck Beams (17" Depth)	Sq Ft	5748
Reinforcement Bars, Epoxy Coated	Pound	21,700
Furnishing Steel Piles HP10x42	Foot	1265
Driving Piles	Foot	1265
Test Pile Steel HP10x42	Each	2
Name Plates	Each	1
Underwater Structure Excavation Protection - Location 1	Each	1
Underwater Structure Excavation Protection - Location 2	Each	1
Asbestos Bearing Pad Removal	Each	40
Bicycle Railing, Special	Foot	140
Controlled Low-Strength Material	Cu Yd	74.8
Parapet Railing	Foot	120
Concrete Encasement	Cu Yd	30.2

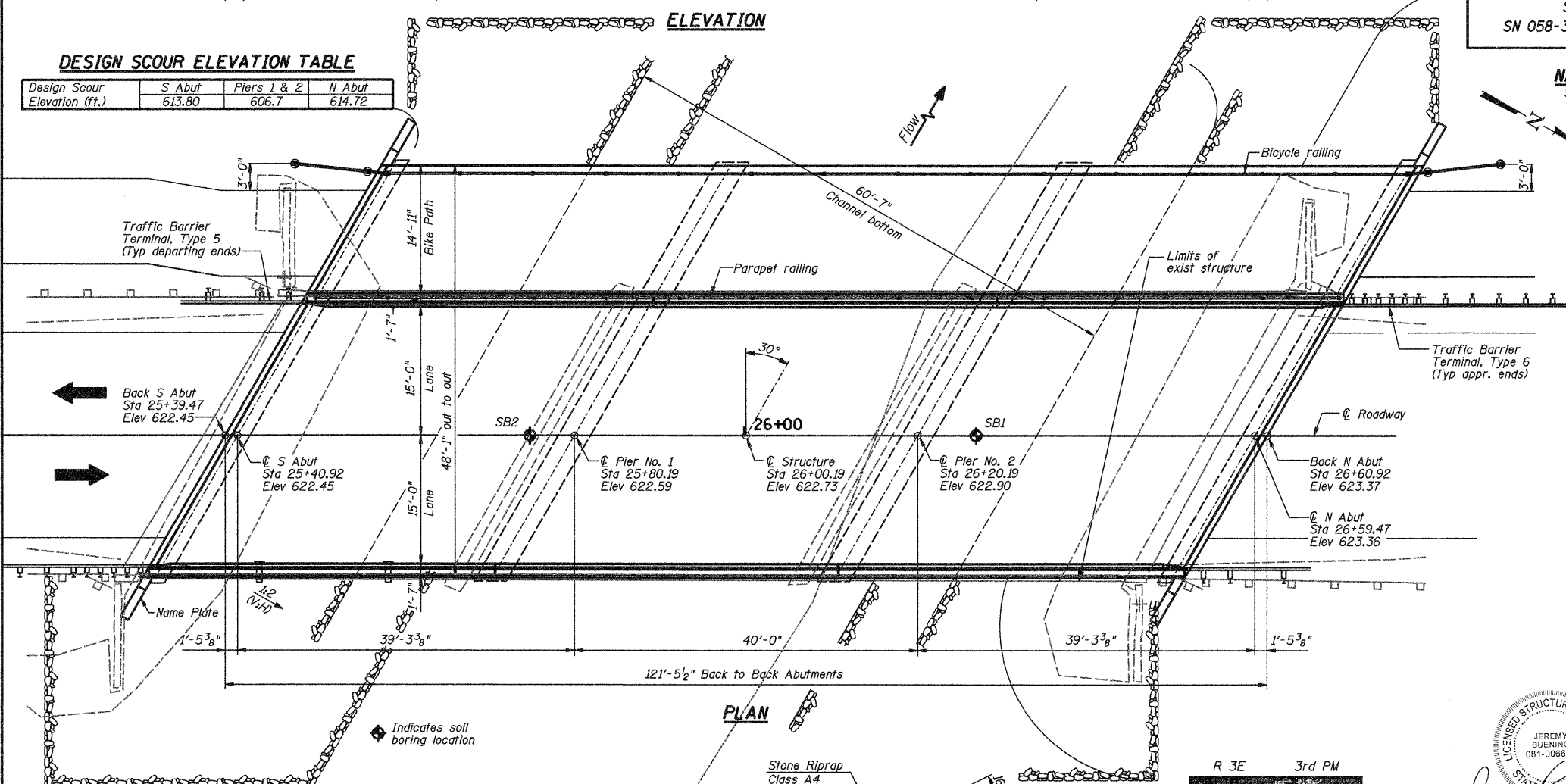

NAME PLATE
See Std. 515001

DESIGN SCOUR ELEVATION TABLE

Design Scour Elevation (ft.)	S Abut	Piers 1 & 2	N Abut
	613.80	606.7	614.72

WATERWAY INFORMATION AT 153' UPSTREAM

Drainage Area = 27.02 sq mi Low Grade Elev. 622.43 @ Sta. 25+36.91

Flood	Freq. Yr.	Q C.F.S.	Opening Sq. Ft.		Nat. H.W.E.		Head - Ft.		Headwater El.	
			Exist.	Prop.	Exist.	Prop.	Exist.	Prop.	Exist.	Prop.
Design	30	2944	461	596	617.46	0.73	0.45	618.19	617.91	
Base	100	3856	724	894	621.04	0.40	0.24	621.44	621.28	
Max. Calc.	500	5171	724	894	621.66	0.72	0.44	622.38	622.10	

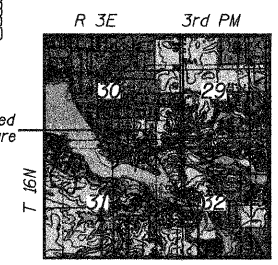
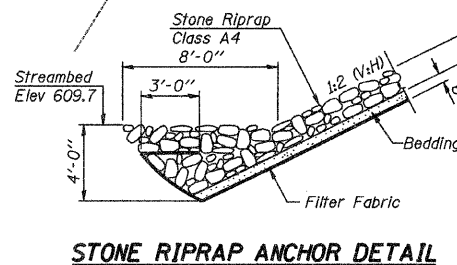

JEREMY BUENING
LICENSED STRUCTURAL ENGINEER
STATE OF ILLINOIS
081-006698
Jeremy Buening, P.E., S.E.
License Expires 11/30/12
Date 4/18/11

I certify that to the best of my knowledge, information and belief, this bridge design is structurally adequate for the design loading shown on the plans. The design is an economical one for the style of structure and complies with requirements of the current AASHTO Standard Specifications for Highway Bridges.

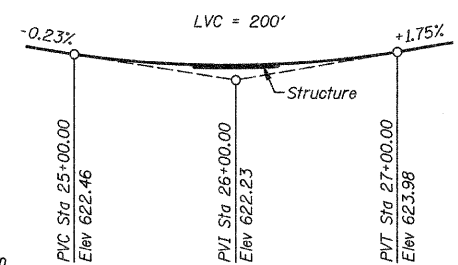

FILE NAME = I:\Municipalities\Macon County\5127 Finley Creek Bridge\CADD\Structural\Revised\gpk	USER NAME = rkung	DESIGNED ACB	REVISED -	 DECATUR (217) 422-8544 CHICAGO (773) 714-0050 ROCKFORD (815) 489-0050 184-001397	GENERAL PLAN AND ELEVATION BALTIMORE AVE (CH 7) OVER FINLEY CREEK SCALE: SHEET NO. 1 OF 12 SHEETS STA. TO STA.	F.A.S. RTE. CH 7	SECTION 05-00198-BR	COUNTY MACON	TOTAL SHEETS 29	SHEET NO. 7
PLOT SCALE = 8x10.0000 "/>										

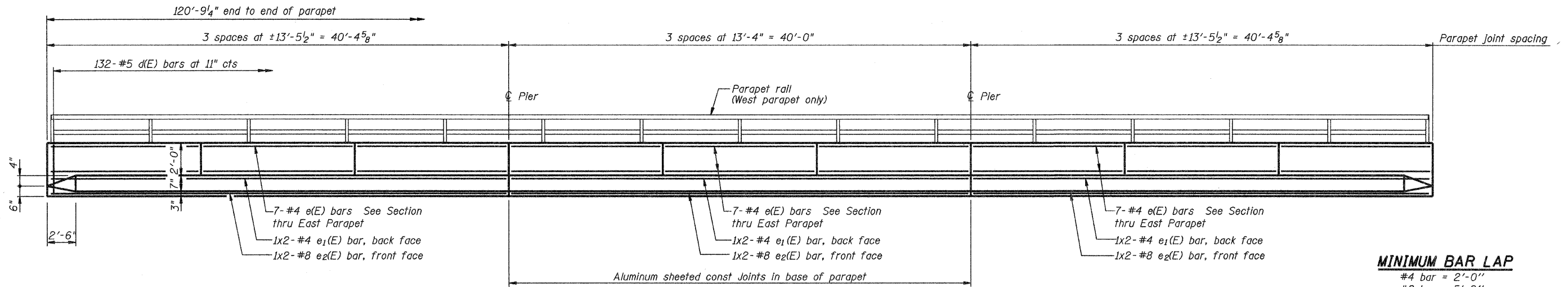

MINIMUM BAR LAP
 #4 bar = 2'-0"
 #8 bar = 5'-2"

INSIDE ELEVATION OF PARAPETS

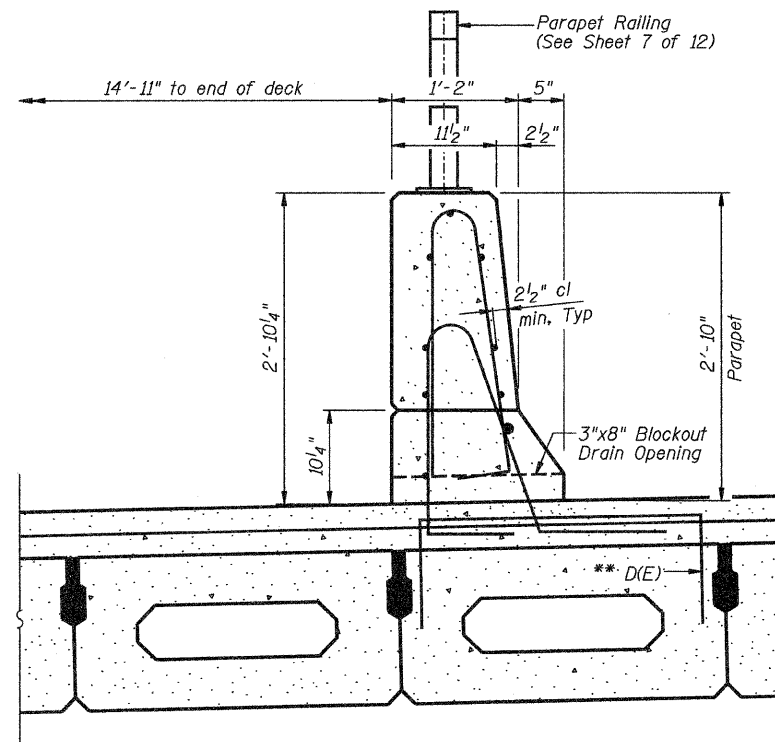

SECTION THRU WEST PARAPET

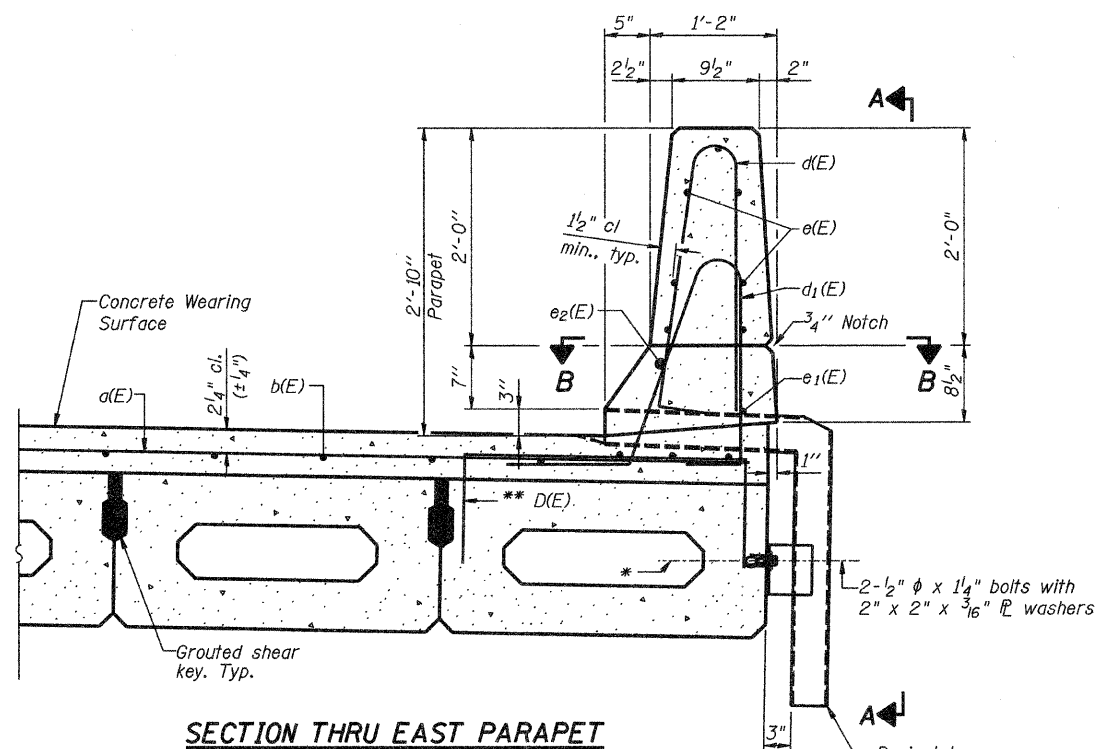

SECTION THRU EAST PARAPET

- * \odot Loop Ferrule inserts for $\frac{1}{2}$ " ϕ bolts. Place at \odot of beam depth.
- ** Place #4 D(E) bars at 9" cts in beam 6 & 16. D(E) bar included in cost of beam. See sheets 6 and 7 of 12 for details.

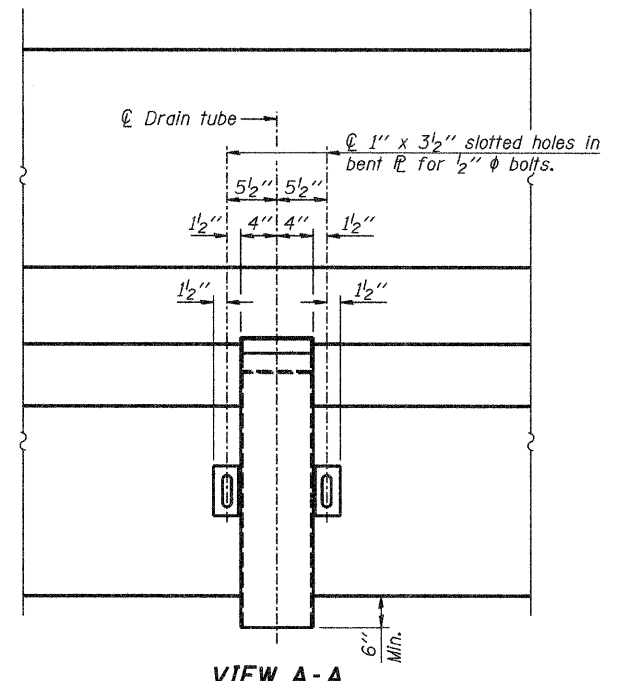

VIEW A-A

Note:
 All drain tubes and accessories shall be galvanized according to AASHTO M111 or M232, (as applicable).
 The cost of the drain tube assemblies and everything necessary for their installation is included with Concrete Superstructure.
 For drain spacing in both parapets see Sheet 2 of 12.

PDS-M-F-D

7-1-10

FILE NAME =	USER NAME = rkung	DESIGNED ACB	REVISED -		DECATUR 617) 422-8544 CHICAGO 773) 714-0050 ROCKFORD (815) 489-0050 184-001997	SUPERSTRUCTURE DETAILS BALTIMORE AVE (CH 7) OVER FINLEY CREEK			F.A.S. RTE.	SECTION	COUNTY	TOTAL SHEETS	SHEET NO.
In\Municipalities\Wacon County\5127 Finley Creek Bridge\CADD_Structural\revised\supdet	DRAWN RLK	CHECKED JMB	REVISED -						CH 7	05-00198-BR	MACON	29	9
PLOT SCALE = 1:8000 ' / IN.	DATE 1-11-11	REVISED -	REVISED -						CONTRACT NO.				
PLOT DATE = 4/18/2011	DATE 1-11-11	REVISED -	REVISED -						ILLINOIS FED. AID PROJECT				

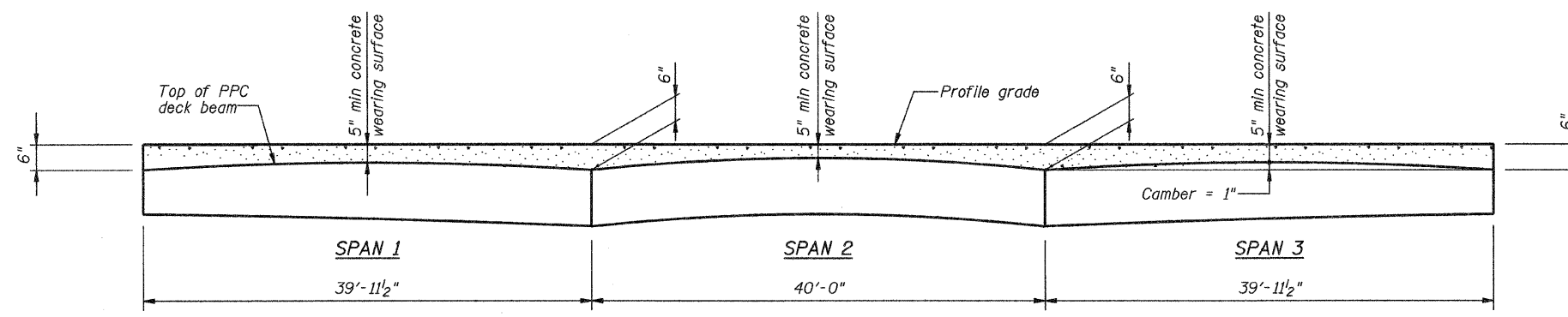

Note:
The thickness of the concrete wearing surface varies as required to adjust for profile grade and beam camber.

REINFORCED CONCRETE WEARING SURFACE PROFILE
(For information only)

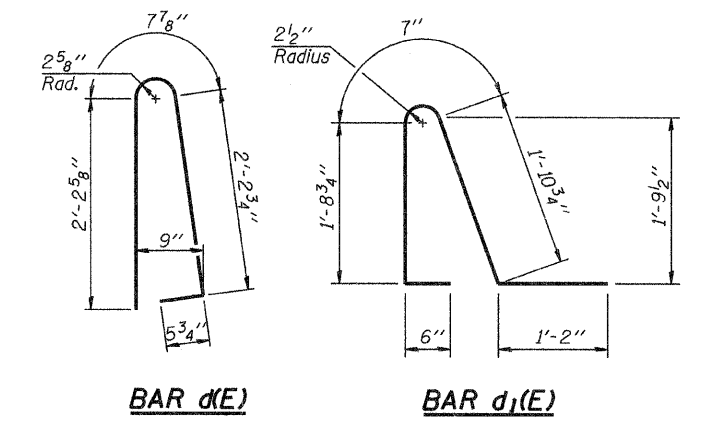

BAR d(E) **BAR d1(E)**

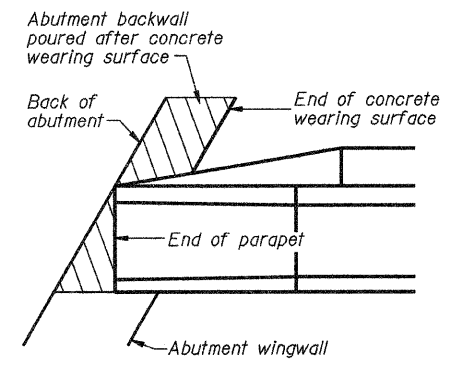
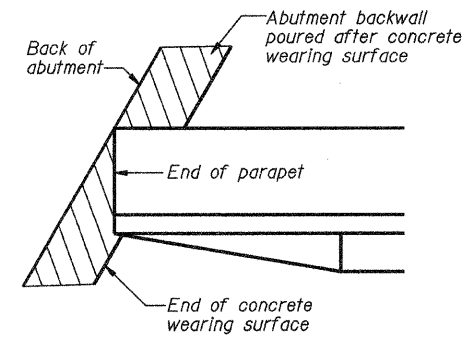

PARAPET END DETAILS
(Occurs at all 4 parapet ends)

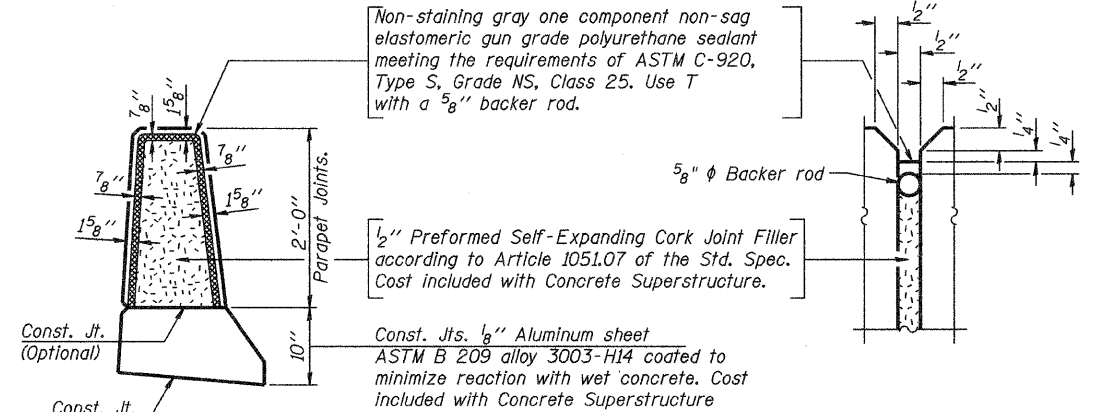

PARAPET JOINT DETAILS

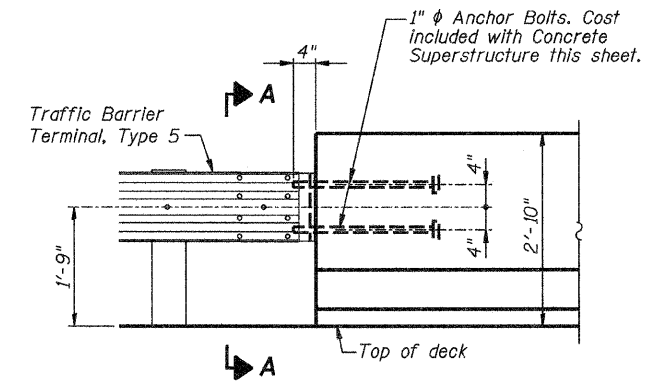

END OF PARAPET ELEVATION

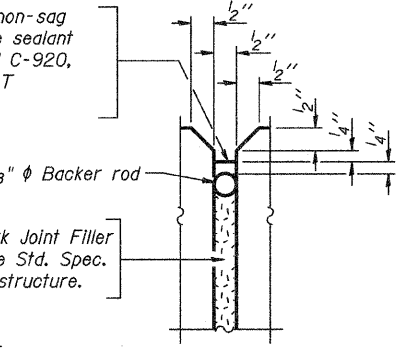

VIEW A-A

(West parapet shown. East parapet similar)

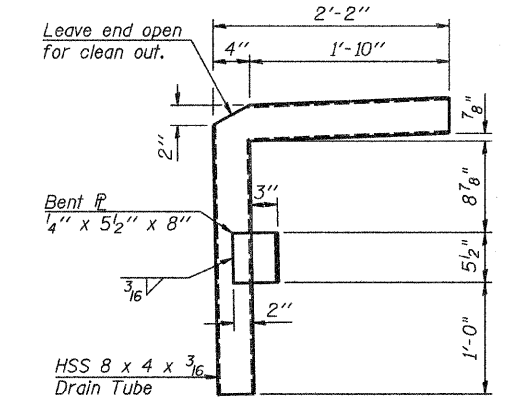

DETAIL A

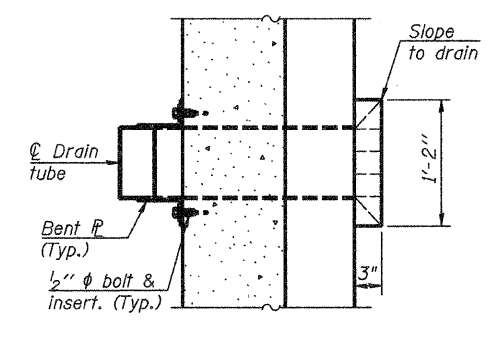

SECTION B-B

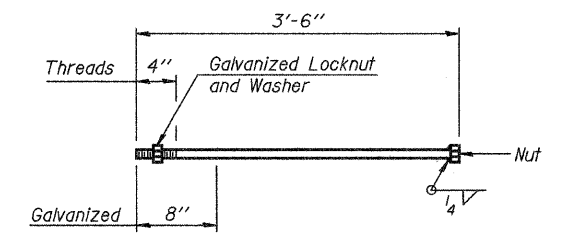

1\"/>

SUPERSTRUCTURE BILL OF MATERIAL

Bar	No.	Size	Length	Shape
a(E)	242	#4	25'-2"	—
b(E)	200	#4	31'-11"	—
d(E)	264	#5	5'-7"	U
d1(E)	264	#5	5'-11"	U
e(E)	126	#4	13'-1"	—
e1(E)	12	#4	21'-1"	—
e2(E)	12	#8	22'-8"	—
Bridge Deck Grooving	Sq. Yd.		378	
Protective Coat	Sq. Yd.		710	
Reinforcement Bars, Epoxy Coated	Pound		13,500	
Concrete Superstructure	Cu. Yd.		28.3	
Concrete Wearing Surface, 5"	Sq. Yd.		639.6	

Bars indicated thus 1 x 2-#4 etc. indicates 1 line of bars with 2 lengths per line.

FILE NAME =	USER NAME = rking	DESIGNED ACB	REVISED -		DECATUR 617) 422-8544	F.A.S. RTE.	SECTION	COUNTY	TOTAL SHEETS	SHEET NO.
In:\Municipalities\Mecon County\5127 Finley Creek Bridge\CADD\Structural\revised\supdet	DRAWN RLK	REVISED -	CHICAGO 773) 714-0050		CH 7	05-00198-BR	MACON	29	10	
PLOT SCALE = 1/8" = 1' IN.	CHECKED JMB	REVISED -	ROCKFORD 815) 489-0050		SCALE:	SHEET NO. 4 OF 12 SHEETS	STA.	TO STA.	CONTRACT NO.	
PLOT DATE = 4/18/2011	DATE 1-11-11	REVISED -	184-001397		ILLINOIS FED. AID PROJECT					

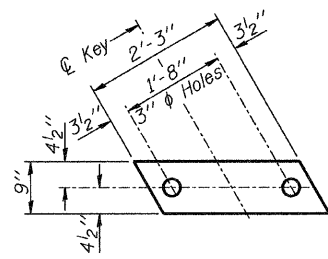

FABRIC BEARING PAD
(Interior)

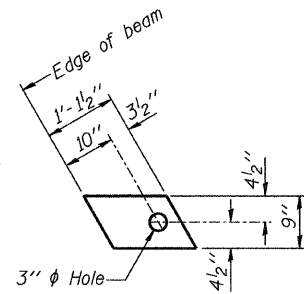

FABRIC BEARING PAD
(Exterior)

FIXED

Notes:
All bearing pads shall be 1" thick.

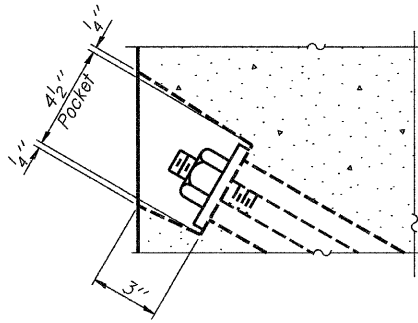

SECTION A-A

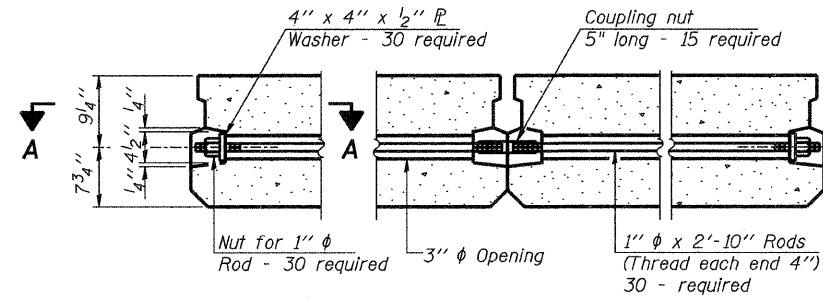

TYPICAL TRANSVERSE TIE ASSEMBLY

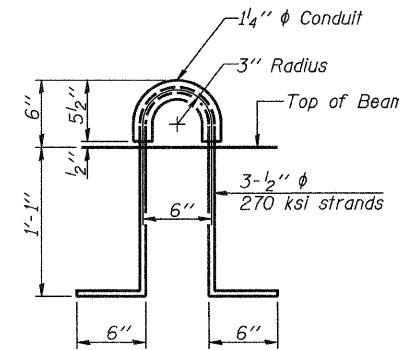

LIFTING LOOP DETAIL

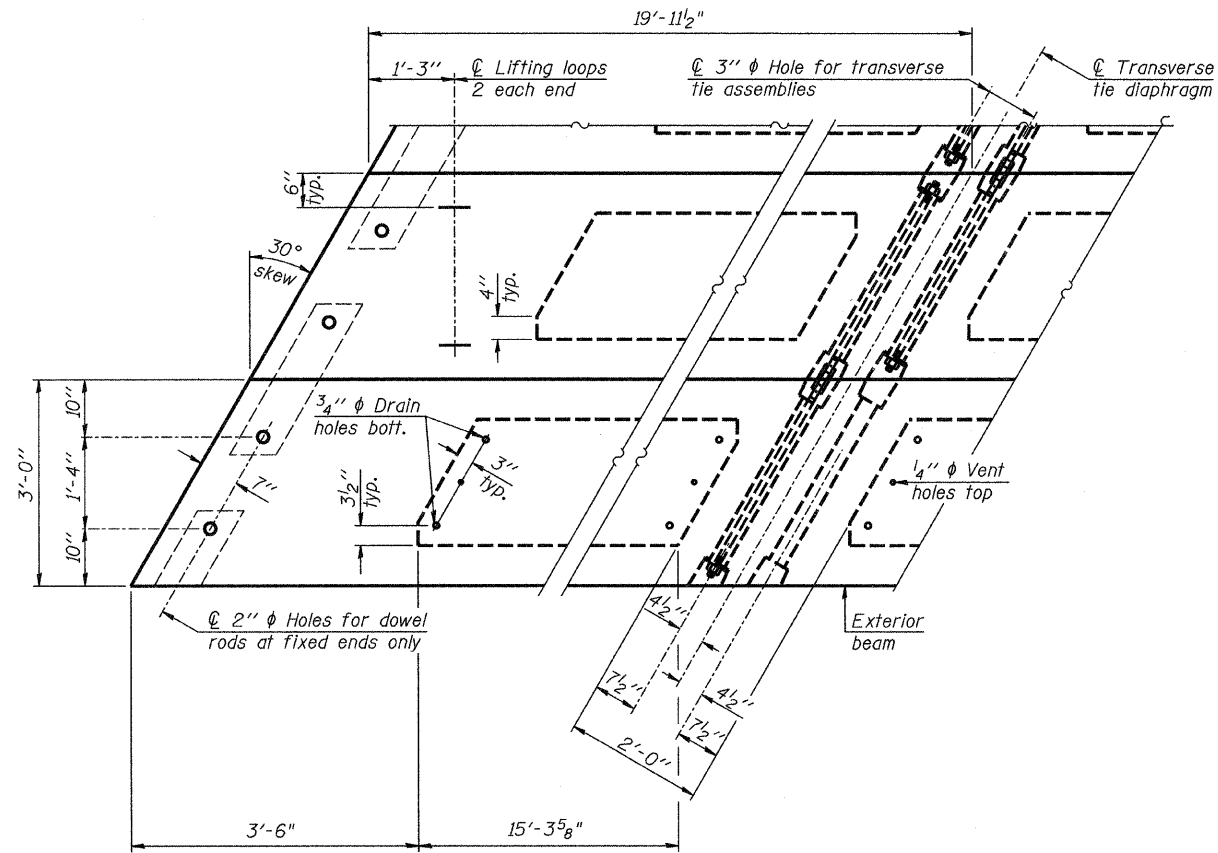

PLAN VIEW

Note: Connect beams in pairs with the transverse tie configuration shown.

NOTES

Prestressing steel shall be uncoated high strength, low relaxation 7-wire strand, Grade 270. The nominal diameter shall be 1/2" and the nominal cross-sectional area shall be 0.153 sq. in.
The 1" rods in the transverse tie assembly shall be tightened to a snug fit and the threads set. Pockets on exterior faces of bridge shall be filled with grout after transverse tie assembly is in place.
Reinforcement bars shall conform to ASTM A 706, Grade 60. (See Special Provisions).
Two 1/8" fabric adjusting shims of the dimensions of the exterior bearing pad shall be provided for each bearing pad location.
A minimum 2 1/2" lifting pin shall be used to engage the lifting loops during handling.
Corrosion Inhibitor, per Article 1020.05(b)(12) and 1021.06 of the Standard Specifications, shall be used in the concrete for precast prestressed concrete deck beams.
Compressive strength of prestressed concrete, f'c, shall be 6000 psi.
Compressive strength of prestressed concrete at release, f'ci, shall be 5000 psi.

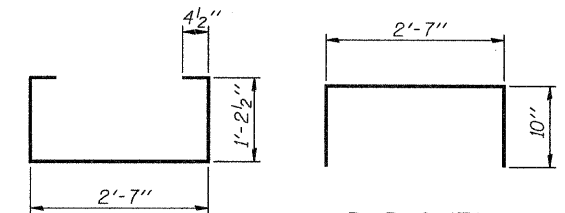

BAR S1(E)

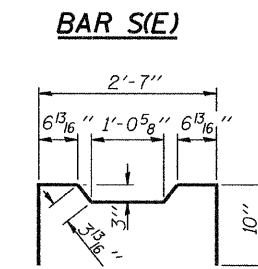

BAR S2(E)

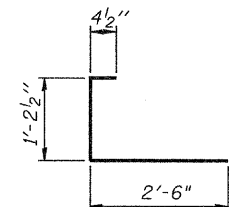

BAR S3(E)

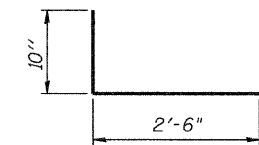

BAR S4(E)

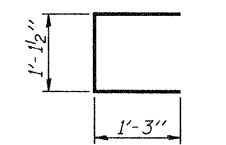

BAR U(E)

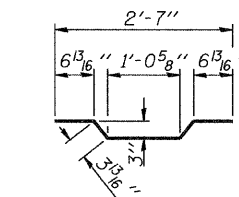

BAR A1(E)

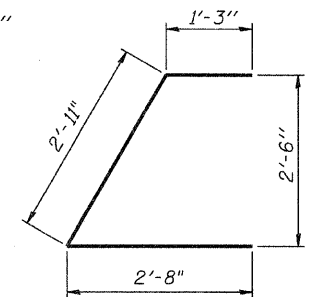

BAR U1(E)

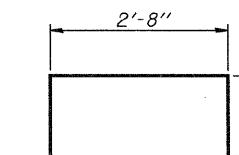

BAR D(E)

BILL OF MATERIAL

Precast Prestressed Conc. Deck Bms. (17" depth)	Sq. Ft.	5748
---	---------	------

PD-1736-LD

7-1-10

FILE NAME =	USER NAME = rking	DESIGNED ACB	REVISED -
In:\Municipalities\Macon County\5127 Finley Creek Bridge\CADD\Structural\revised\beam	DRAWN RLK	REVISED -	
PLOT SCALE = 1/8" = 1'-0"	CHECKED JMB	REVISED -	
PLOT DATE = 4/18/2011	DATE 1-11-11	REVISED -	

HOMER L. CHASTAIN & ASSOCIATES, LLP
CONSULTING ENGINEERS

DECATUR 317 422-8544
CHICAGO 773 714-0050
ROCKFORD 815 489-0050
184-001997

17" x 36" PPC DECK BEAM DETAILS
BALTIMORE AVE (CH 7) OVER FINLEY CREEK

SCALE: SHEET NO. 5 OF 12 SHEETS STA. TO STA.

F.A.S. RTE.	SECTION	COUNTY	TOTAL SHEETS	SHEET NO.
CH 7	05-00198-BR	MACON	29	11
CONTRACT NO.			ILLINOIS FED. AID PROJECT	

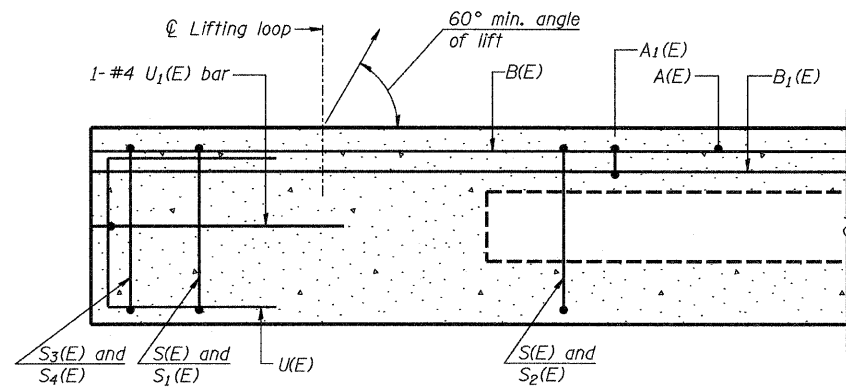

SECTION A-A

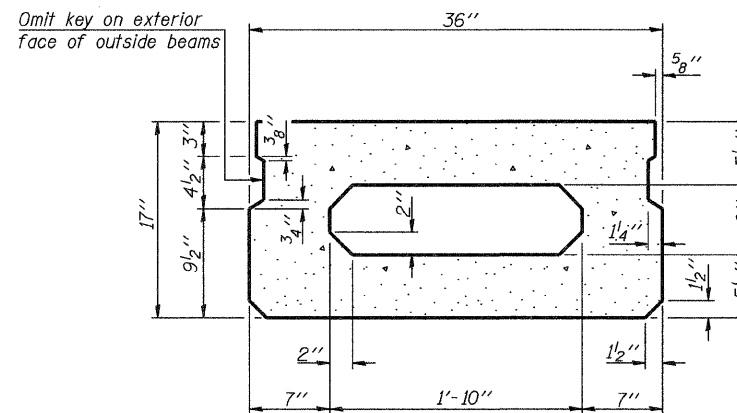

SECTION B-B
(Showing dimensions)

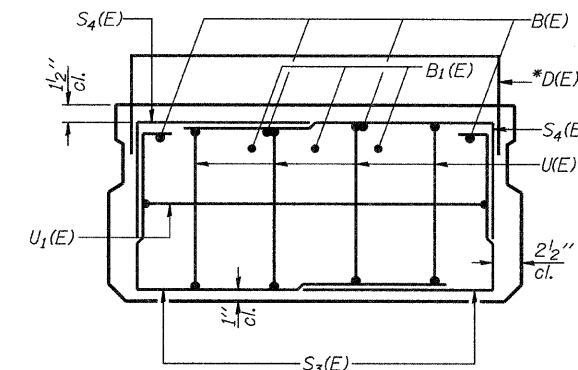

VIEW C-C

*Provide only for beams 6 and 16.

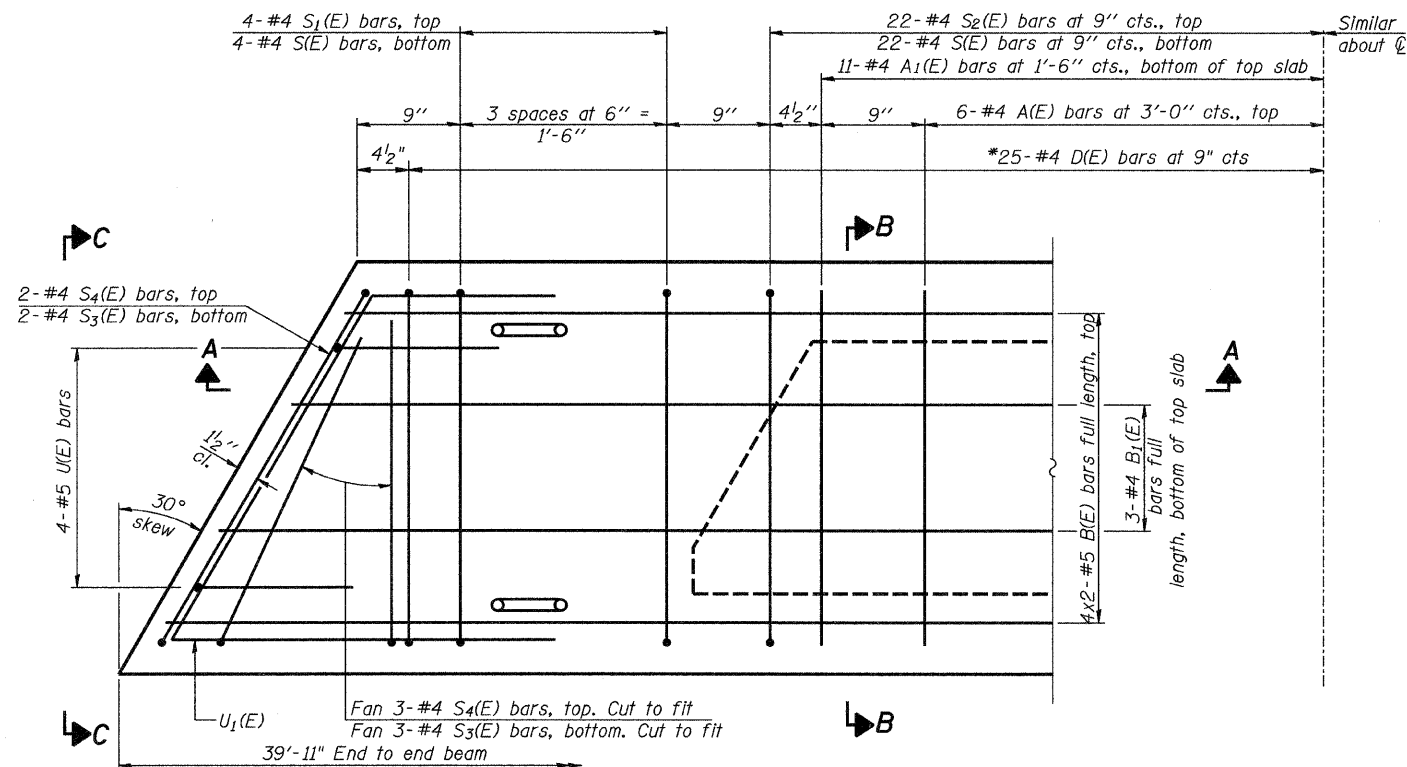

PLAN VIEW

Note: Spacing of S(E) and S2(E) bars may be adjusted up to 4" in the immediate area of the transverse tie diaphragms to miss the block outs for the transverse ties.

*Provide only for beams 6 and 16.

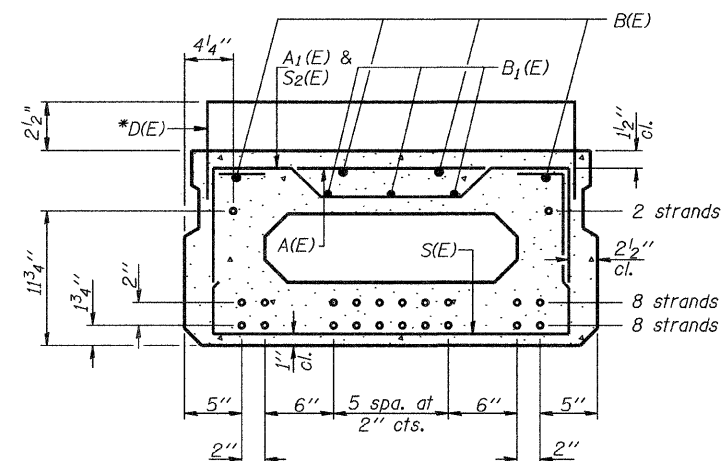

SECTION B-B

(Showing reinforcement and permissible strand locations)

Note: Place the number of strands specified in each row symmetrically about the centerline of beam in the permissible strand locations shown.

*Provide only for beams 6 and 16.

BAR LIST
ONE BEAM ONLY
(For information only)

Bar	No.	Size	Length	Shape
A(E)	11	#4	2'-7"	—
A1(E)	22	#4	2'-10"	—
B(E)	8	#5	2'-3"	—
B1(E)	6	#4	2'-3"	—
D(E)	51	#4	4'-8"	⌌
S(E)	53	#4	5'-9"	⌌
S1(E)	8	#4	4'-3"	⌌
S2(E)	45	#4	4'-6"	⌌
S3(E)	10	#4	4'-1"	⌌
S4(E)	10	#4	3'-4"	⌌
U(E)	8	#5	3'-8"	⌌
U1(E)	2	#4	6'-10"	⌌

Note: See sheet 5 of 12 for additional details and Bill of Material.

*Provide only for beams 6 and 16.

MINIMUM BAR LAP

#4 bar = 2'-0"
#5 bar = 2'-6"

PD-1736-L

7-1-10

FILE NAME =	USER NAME = rking	DESIGNED ACB	REVISED -		DECATUR (217) 422-8544 CHICAGO (773) 714-0050 ROCKFORD (815) 489-0050 184-001597	17" x 36" PPC DECK BEAM BALTIMORE AVE (CH 7) OVER FINLEY CREEK		F.A.S. RTE.	SECTION	COUNTY	TOTAL SHEETS	SHEET NO.
In:\Municipalities\Macon County\5127 Finley Creek Bridge\CADD\Structural\revised\beam	DRAWN RLK	REVISED -	CH 7					05-00198-BR	MACON	29	12	
PLOT SCALE = 1/8" = 1'-0"	CHECKED JMB	REVISED -	CONTRACT NO.									
PLOT DATE = 4/18/2011	DATE 1-11-11	REVISED -	ILLINOIS FED. AID PROJECT									

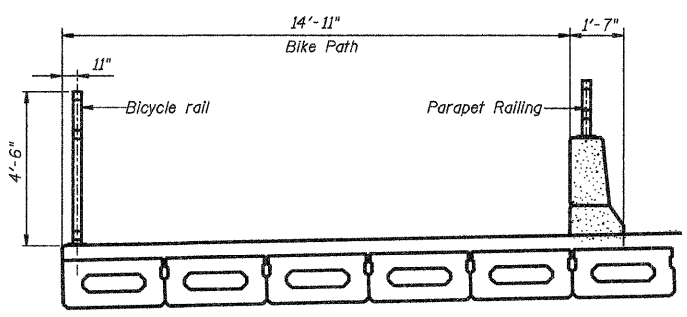
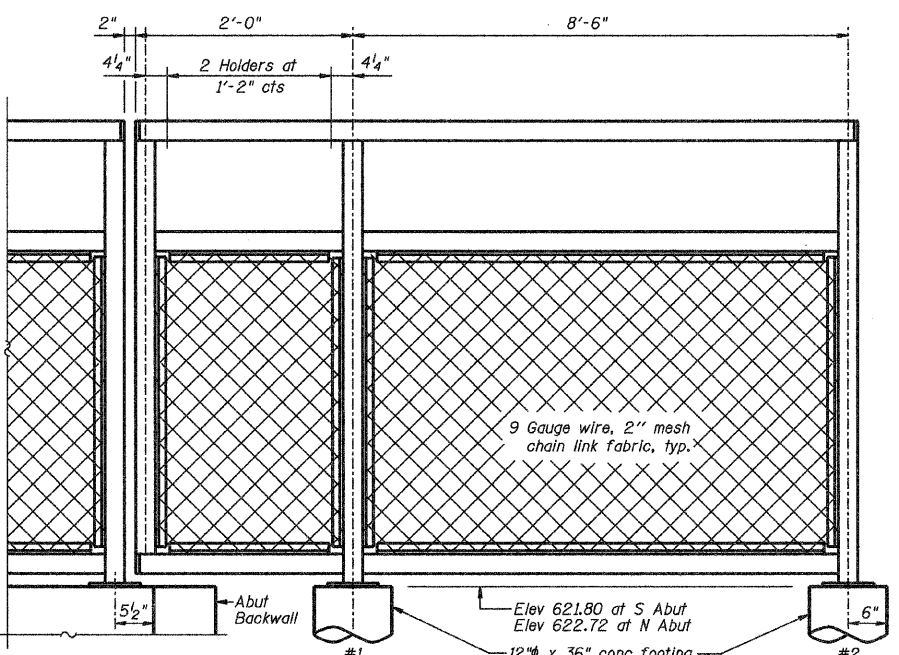
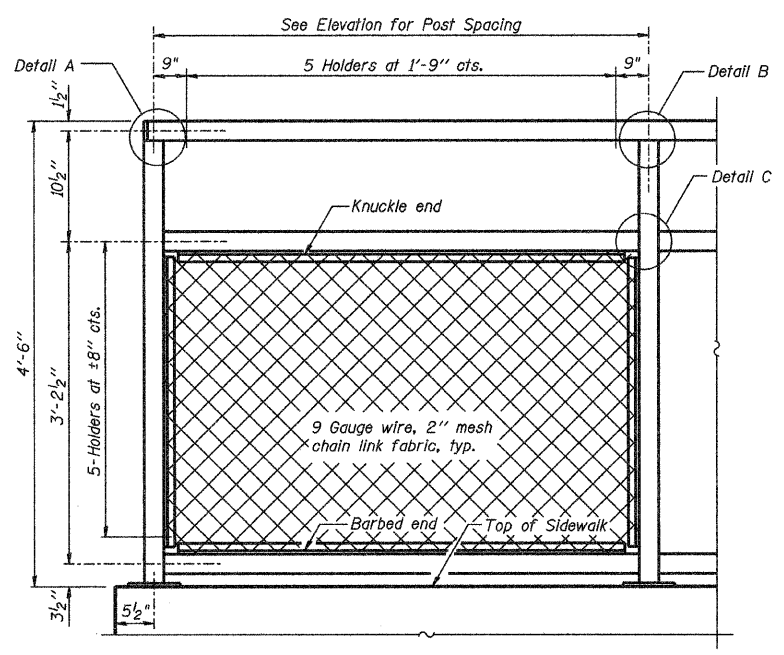
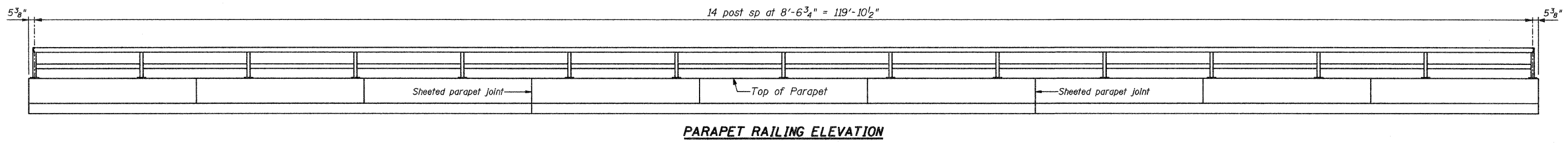
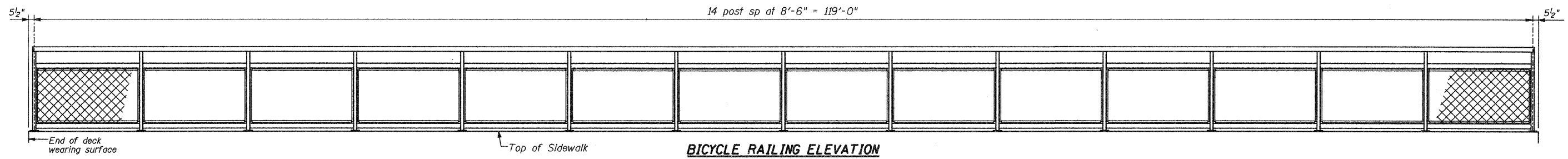

NOTES
 The chain link fabric shall be black vinyl coated and conform to the requirements of Article 1006.27(a)(1) of the Standard Specifications.
 All posts, railing, splices, anchor devices and bent plates shall be painted using one of the two following paint systems:
 1. Inorganic Zinc-rich/Waterborne Acrylic for shop and field applications.
 2. Organic Zinc-rich/Epoxy/Urethane for full shop application.
 Finish paint color shall be NI-Black. See Special Provision "Cleaning and Painting New Metal Structures."
 Footings for bicycle railing end panels shall be included in cost of Bicycle Railing, Special.
 There will be a conflict with the bicycle railing concrete footings and the CLSM behind the abutment. The Contractor shall make adjustments so that full footing depth can be achieved.

FOOTING LOCATION

Description	Station	Offset
S Abut #1	25+56.08	30.80' Lt
S Abut #2	25+47.63	31.71' Lt
N Abut #1	26+79.63	30.80' Lt
N Abut #2	26+88.08	31.71' Lt

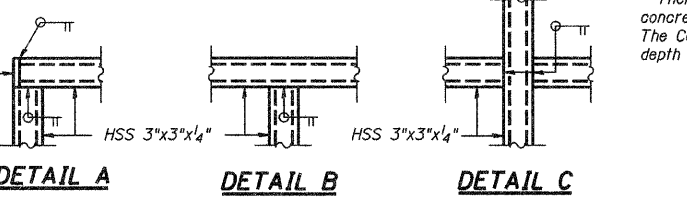
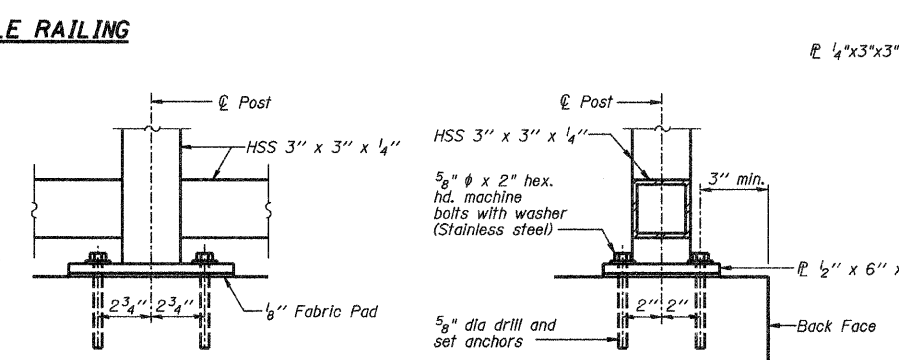
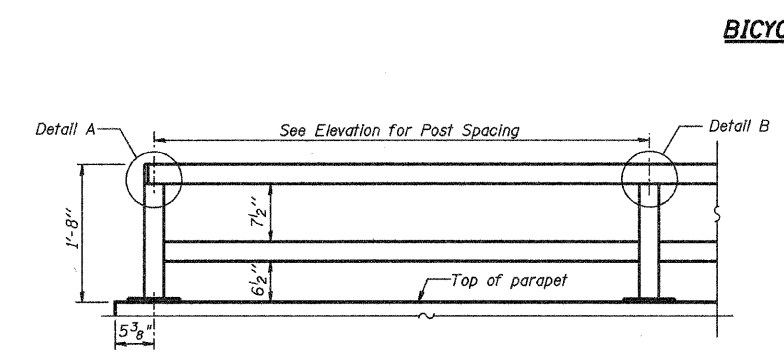

BILL OF MATERIAL

Item	Unit	Quantity
Bicycle Railing, Special	Foot	140
Parapet Railing	Foot	120

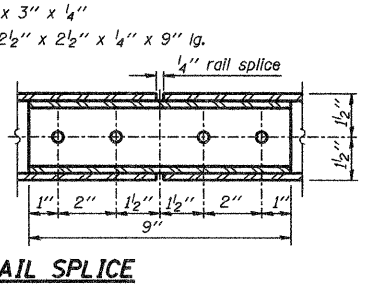
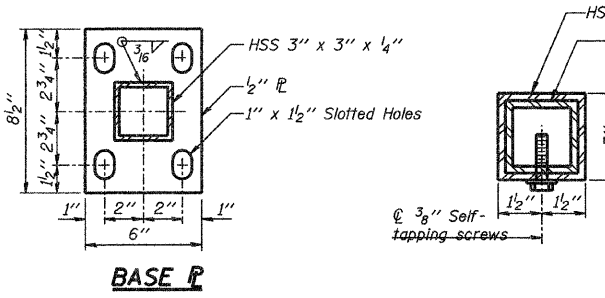

The Contractor shall drill and set 5/8" dia anchor rods according to Article 509.06 of the Standard Specifications. Embedment shall be according to the manufacturer's specifications and shall not exceed 5".

(10'-0" Maximum Post Spacing)

FILE NAME =	USER NAME = rking	DESIGNED ACB	REVISED -
I:\Municipalities\Moon_County\5127 Finl	Creek Bridge\CADD_Structural\Revised\Bicyc	DRAWN RLK	REVISED -
PLOT SCALE = 4.0000' / IN.	CHECKED JMB	DATE 1-11-11	REVISED -
PLOT DATE = 4/18/2011			REVISED -

HOMER L. CHASTAIN & ASSOCIATES, LLP
 CONSULTING ENGINEERS

DECATUR (317) 422-8544
 CHICAGO (773) 714-0050
 ROCKFORD (815) 489-0050
 184-001897

BICYCLE RAIL DETAILS
BALTIMORE AVE (CH 7) OVER FINLEY CREEK

SCALE: SHEET NO. 7 OF 12 SHEETS STA. TO STA.

F.A.S. RTE.	SECTION	COUNTY	TOTAL SHEETS	SHEET NO.
CH 7	05-00198-BR	MACON	29	13

CONTRACT NO. [ILLINOIS] FED. AID PROJECT

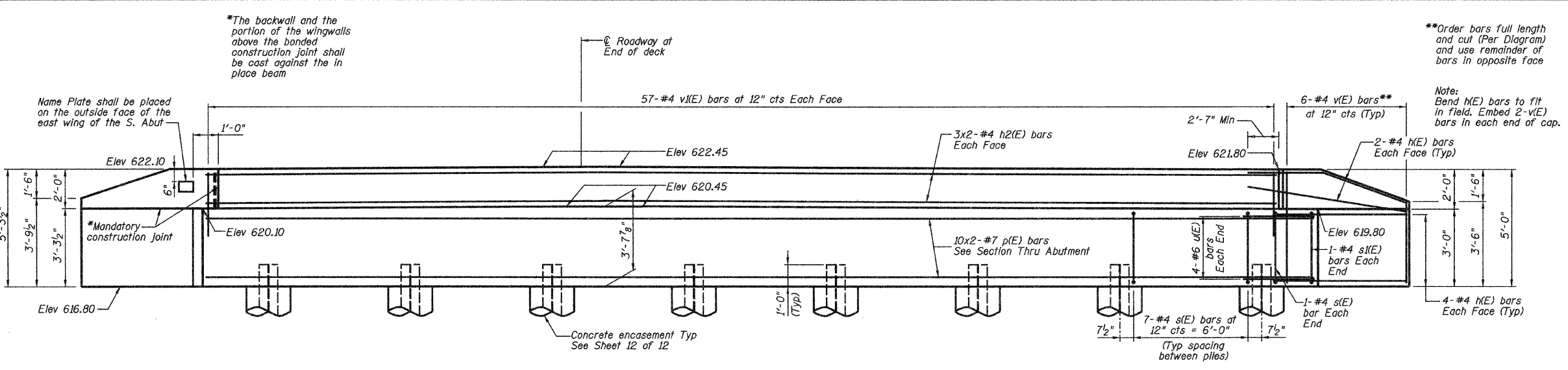

ELEVATION

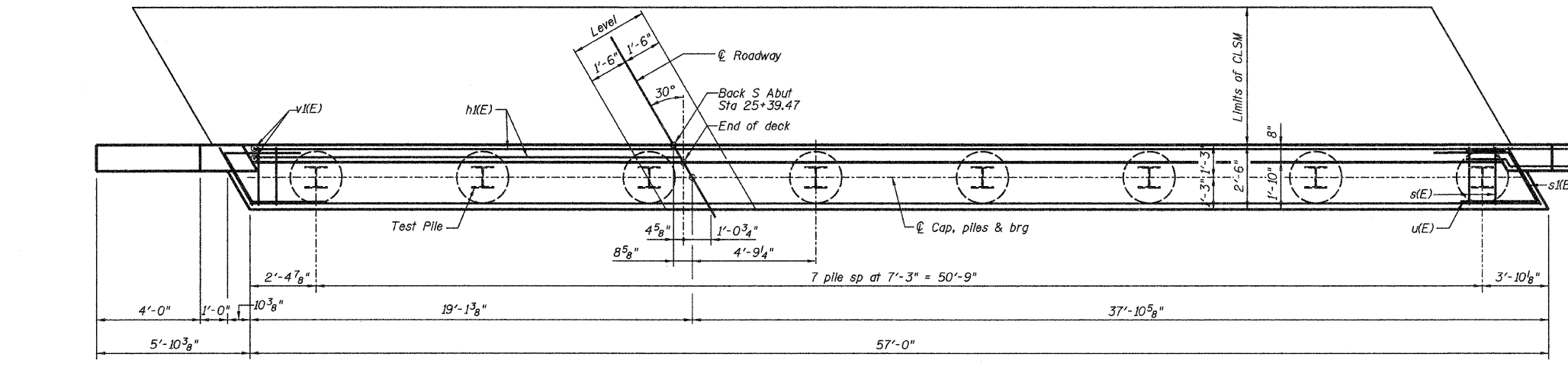

PLAN

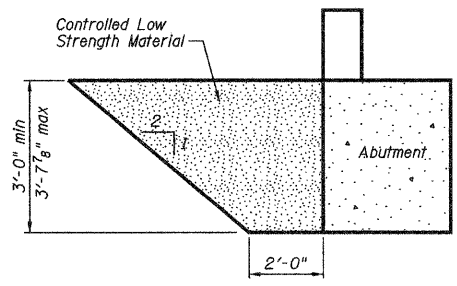

CONTROLLED LOW STRENGTH MATERIAL LIMITS
(Dimensions at right L's)

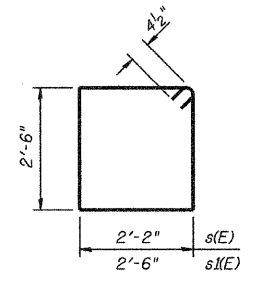

BARS s(E) and s(E)

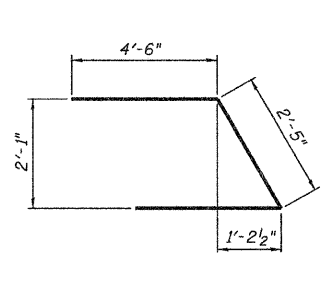

BAR u(E)

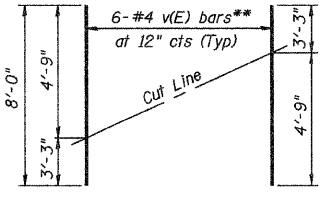

FIELD CUTTING DIAGRAM
**Order v(E) full length. Cut as shown and use remainder of bars in opposite face.

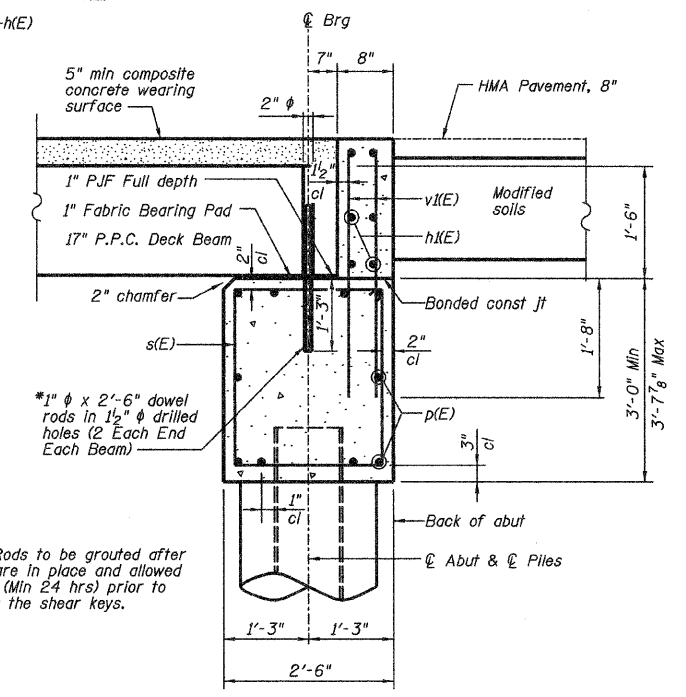

SECTION THRU ABUTMENT
(Dimensions at Rt L's)

BILL OF MATERIAL

Bar No.	Size	Length	Shape
h(E)	#4	4'-8"	—
h(E)	#4	29'-9"	—
p(E)	#7	31'-0"	—
s(E)	#4	10'-1"	□
s(E)	#4	10'-9"	□
u(E)	#6	11'-5"	∩
v(E)	#4	8'-0"	—
v(E)	#4	3'-6"	—
Structure Excavation	Cu Yd	50	
Concrete Structures	Cu Yd	22.4	
Reinforcement Bars, Epoxy Coated	Pound	2410	
Furnishing Steel Piles HP10x42	Foot	280	
Driving Piles	Foot	280	
Test Pile	Each	1	
Controlled Low Strength Material	Cu Yd	37.4	
Concrete Encasement	Cu Yd	2.8	

NOTES

The cost of excavation and reinforcement for pile encasement is incidental to the cost of "Concrete Encasement."
Reinforcement bars designated (E) shall be epoxy coated.
Cast backwall after beams and concrete wearing surface has been erected.

PILE DATA:

Type: Steel HP10x42
Nominal Required Bearing: 183 kips
Allowable Resistance Available: 61 kips
Est. Length: 40'
No. Production Piles: 7
No. Test Piles: 1

FILE NAME =	USER NAME = #USER#	DESIGNED ACB	REVISED -		DECATUR (317) 422-8544	SOUTH ABUTMENT DETAILS		F.A.S. RTE.	SECTION	COUNTY	TOTAL SHEETS	SHEET NO.	
#FILE#		DRAWN RLK	REVISED -		CHICAGO (773) 714-0050	BALTIMORE AVE (CH 7) OVER FINLEY CREEK		CH 7	05-00198-BR	MACON	29	14	
		CHECKED JMB	REVISED -		ROCKFORD (815) 489-0050	SCALE:	SHEET NO. 8 OF 12 SHEETS	STA.					
		DATE 1-11-11	REVISED -		184-001397			TO STA.					

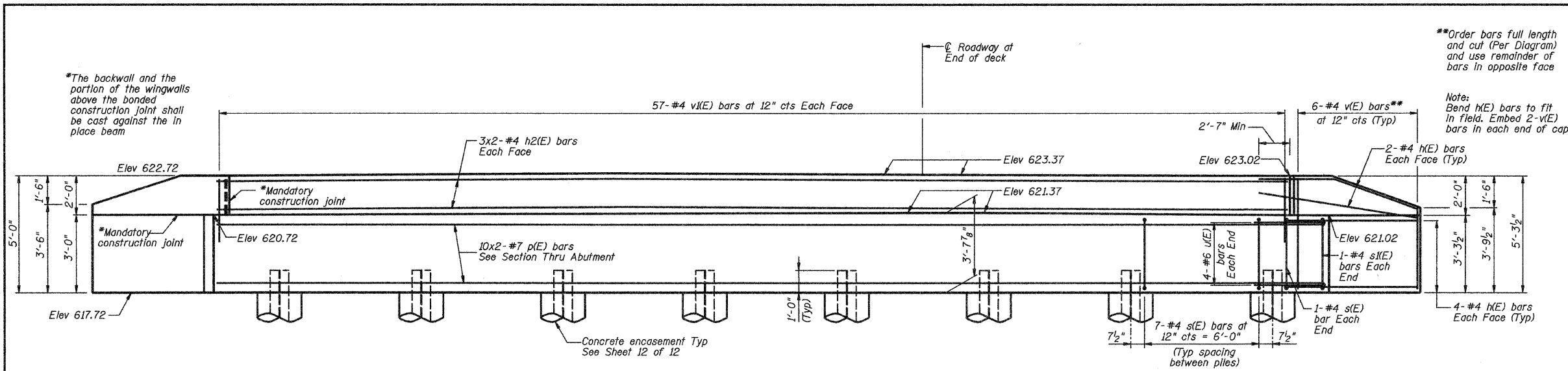

BILL OF MATERIAL

Bar	No.	Size	Length	Shape
h(E)	24	#4	4'-8"	—
h(E)	12	#4	29'-9"	—
p(E)	20	#7	31'-0"	—
s(E)	51	#4	10'-1"	□
s(E)	2	#4	10'-9"	□
u(E)	8	#6	11'-5"	—
v(E)	12	#4	8'-0"	—
v(E)	114	#4	3'-6"	—
Structure Excavation			Cu Yd	60
Concrete Structures			Cu Yd	22.4
Reinforcement Bars, Epoxy Coated			Pound	2410
Furnishing Steel Piles HP10x42			Foot	320
Driving Piles			Foot	320
Controlled Low Strength Material			Cu Yd	37.4
Concrete Encasement			Cu Yd	2.8

ELEVATION

MIN BAR LAP
 #4 bar = 2'-7"
 #7 bar = 5'-2"

NOTES

The cost of excavation and reinforcement for pile encasement is incidental to the cost of "Concrete Encasement."
 Reinforcement bars designated (E) shall be epoxy coated.
 Cast backwall after beams and concrete wearing surface has been erected.

PILE DATA:

Type: Steel HP10x42
 Nominal Required Bearing: 183 kips
 Allowable Resistance Available: 61 kips
 Est. Length: 40'
 No. Production Piles: 8
 No. Test Piles: 0

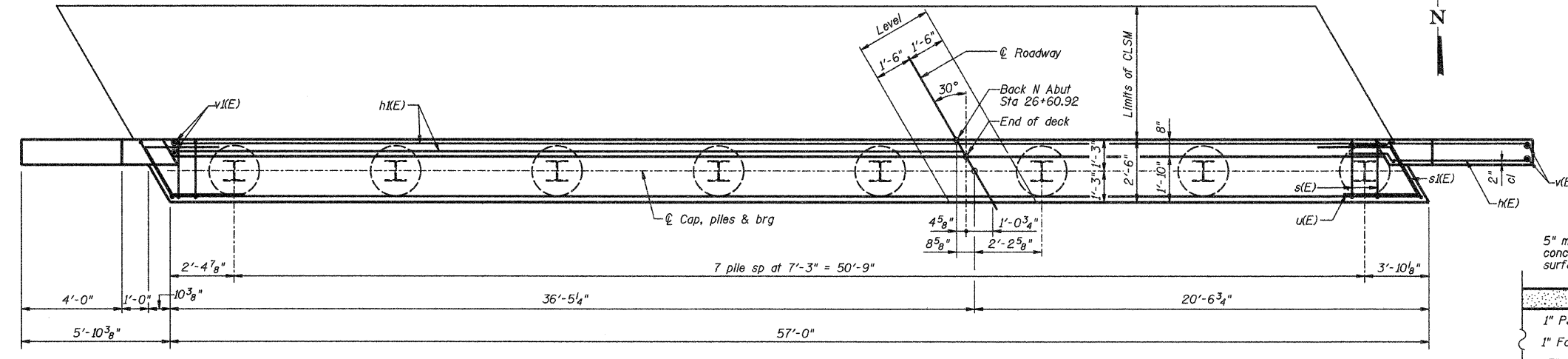

PLAN

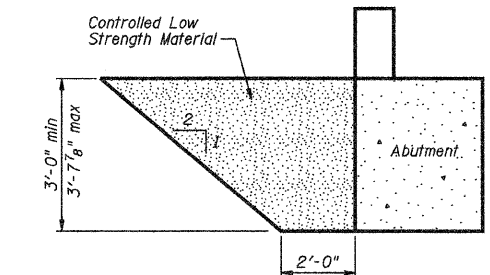

CONTROLLED LOW STRENGTH MATERIAL LIMITS
 (Dimensions at right L's)

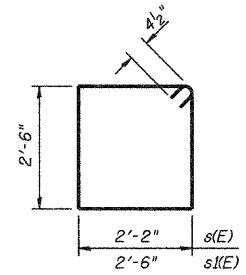

BARS s(E) and s(E)

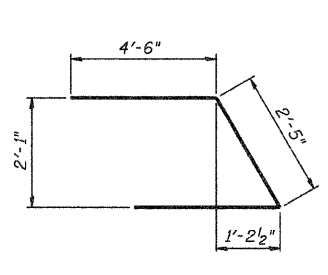

BAR u(E)

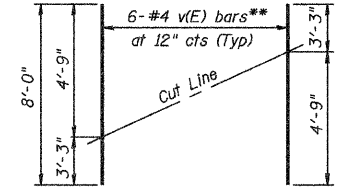

FIELD CUTTING DIAGRAM
 **Order v(E) full length. Cut as shown and use remainder of bars in opposite face.

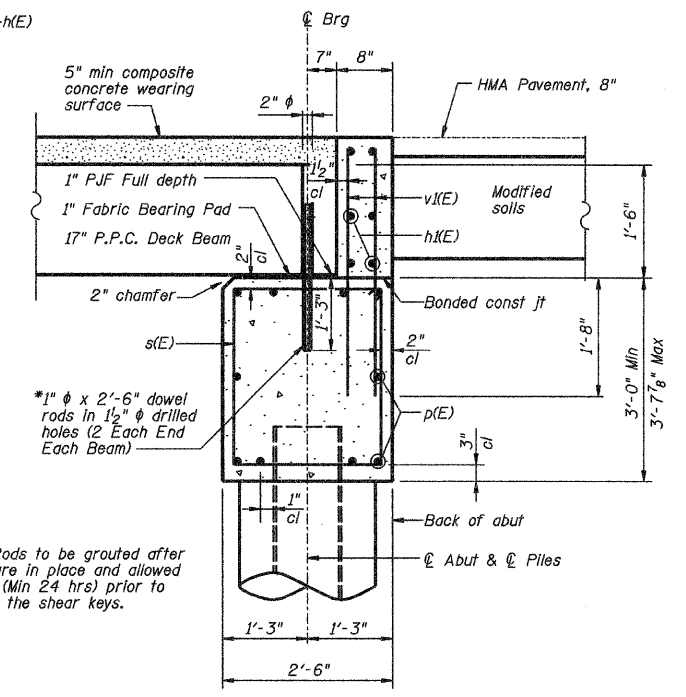

SECTION THRU ABUTMENT
 (Dimensions at Rt L's)

FILE NAME =	USER NAME = rking	DESIGNED ACB	REVISED -	HOMER L. CHASTAIN & ASSOCIATES, LLP CONSULTING ENGINEERS DECATUR CHICAGO ROCKFORD (217) 422-8544 (773) 714-0050 (616) 489-0850 184-001997	NORTH ABUTMENT DETAILS BALTIMORE AVE (CH 7) OVER FINLEY CREEK SCALE: SHEET NO. 9 OF 12 SHEETS STA. TO STA.		F.A.S. RTE.	SECTION	COUNTY	TOTAL SHEETS	SHEET NO.
Ir\Municipal\tees\Mecon.County\5127 Finley Creek Bridge\CADD_Structural\revised\abut	Creek Bridge\CADD_Structural\revised\abut	DRAWN RLK	REVISED -				CH 7	05-00198-BR	MACON	29	15
PLOT SCALE = 2:8.0000 '1\"/>											
PLOT DATE = 4/18/2011	DATE 1-11-11	CHECKED JMB	REVISED -				CONTRACT NO.			ILLINOIS FED. AID PROJECT	

**After beams have been erected, holes shall be drilled into substructure and anchor dowels placed. Dowel holes shall be filled with non-shrink grout to top of beam and allowed to cure min 24 hrs prior to grouting the shear keys.

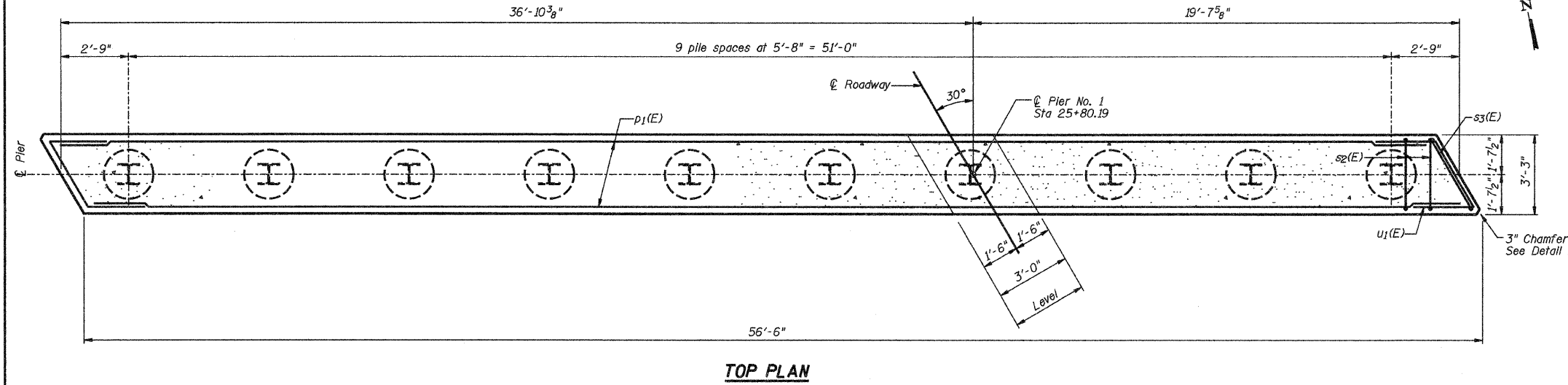

TOP PLAN

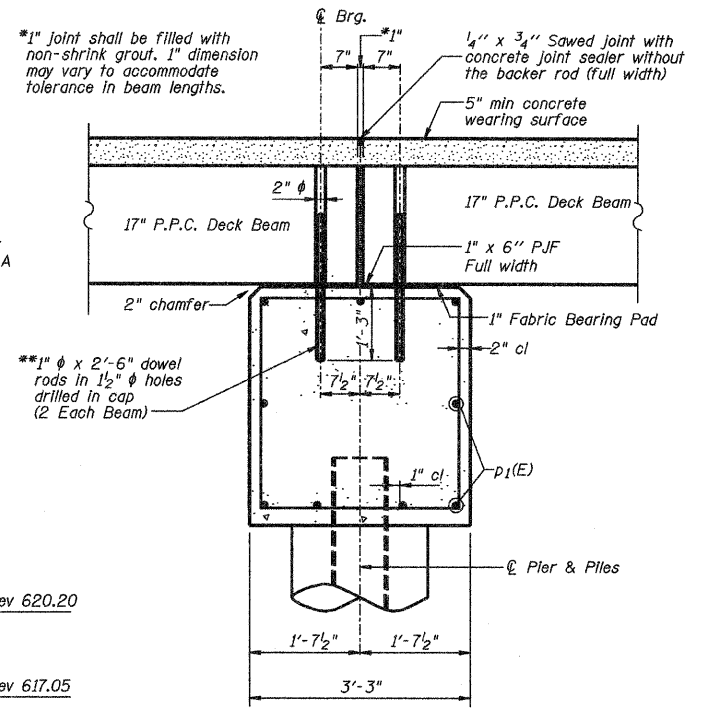

SECTION THRU PIER
(Dimensions at Rt L's)

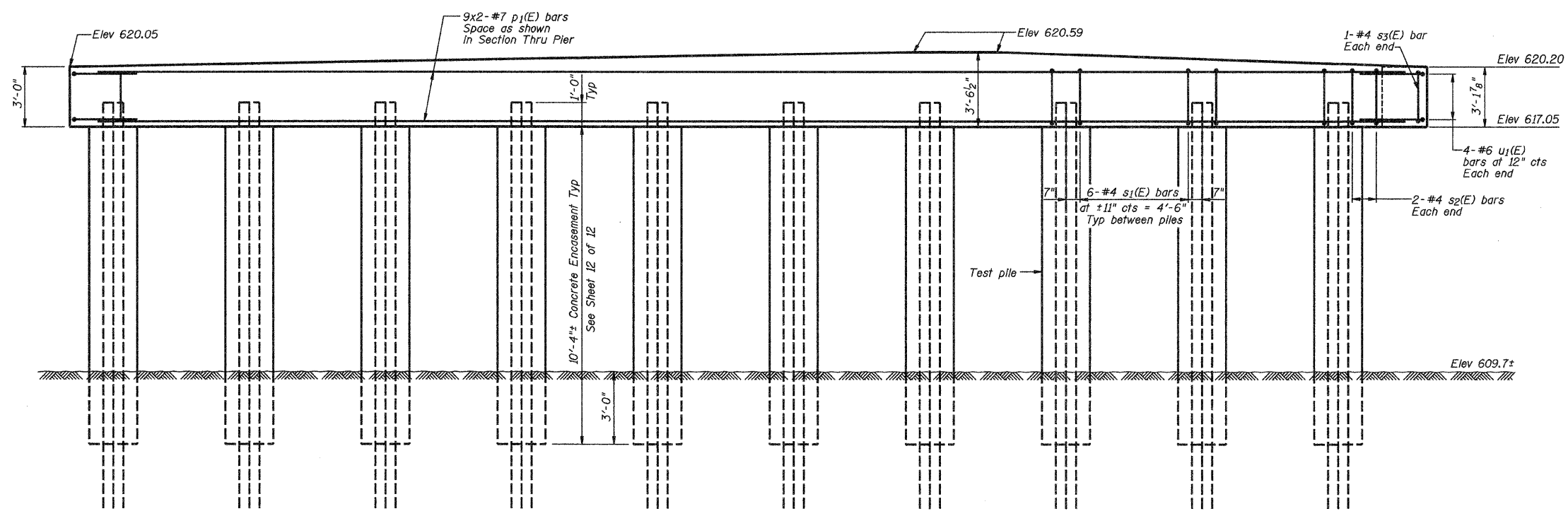

ELEVATION
(Looking Up Station)

BILL OF MATERIAL

Bar	No.	Size	Length	Shape
p1(E)	18	#7	30'-8"	—
sg(E)	58	#4	11'-11"	□
s3(E)	2	#4	12'-9"	□
u1(E)	8	#6	12'-4"	⌒
Concrete Encasement		Cu Yd	12.1	
Concrete Structures		Cu Yd	22.1	
Reinforcement Bars, Epoxy Coated		Pound	1690	
Furnishing Steel Piles HP 10x42		Foot	315	
Driving Piles		Foot	315	
Test Pile		Each	1	
Underwater Structure Excavation Protection Location 1		Each	1	

PILE DATA

Type: Steel HP 10x42
 Nominal Required Bearing: 228 kips
 Allowable Resistance Available: 76 kips
 Est. Length: 35'
 No. Production Piles: 9
 No. Test Piles: 1

MIN BAR LAP
#7 bar = 5'-2"

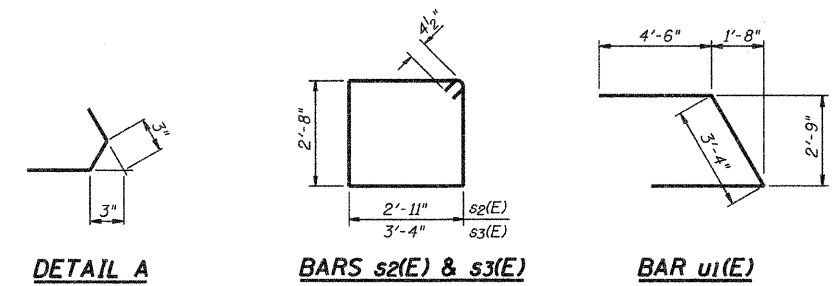

DETAIL A

BARS s2(E) & s3(E)

BAR u1(E)

NOTES

The cost of excavation and reinforcement for pile encasement is incidental to the cost of "Concrete Encasement."
 Reinforcement bars designated (E) shall be epoxy coated.

FILE NAME =	USER NAME = rking	DESIGNED ACB	REVISED -	HOMER L. CHASTAIN & ASSOCIATES, LLP CONSULTING ENGINEERS DECATUR (217) 422-8544 CHICAGO (773) 714-0050 ROCKFORD (815) 489-0050 184-001597	PIER NO. 1 DETAILS		F.A.S. RTE.	SECTION	COUNTY	TOTAL SHEETS	SHEET NO.
In:\Municipalities\Wacon County\8127 Finley Creek Bridge\CADD_Structural\revised\pier1	Creek Bridge\CADD_Structural\revised\pier1	DRAWN RLK	REVISED -		BALTIMORE AVE (CH 7) OVER FINLEY CREEK		CH 7	05-00198-BR	MACON	29	16
PLOT SCALE = 2/8" = 1" / IN.		CHECKED JMB	REVISED -		SCALE:	SHEET NO. 10 OF 12 SHEETS	STA.	CONTRACT NO.			
PLOT DATE = 4/18/2011		DATE 1-11-11	REVISED -		ILLINOIS FED. AID PROJECT						

**After beams have been erected, holes shall be drilled into substructure and anchor dowels placed. Dowel holes shall be filled with non-shrink grout to top of beam and allowed to cure min 24 hrs prior to grouting the shear keys.

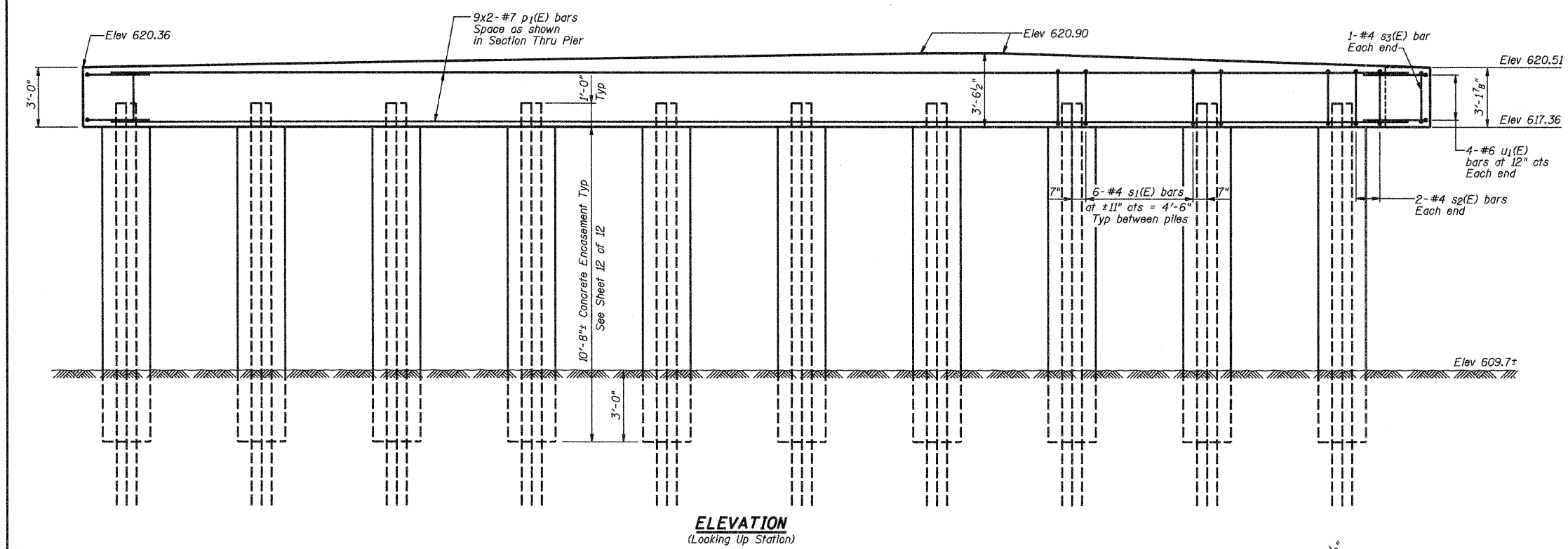
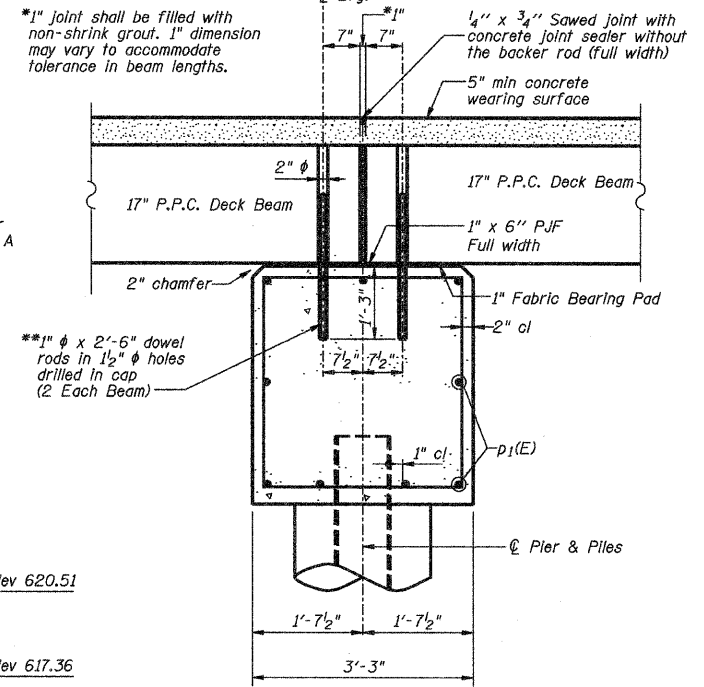
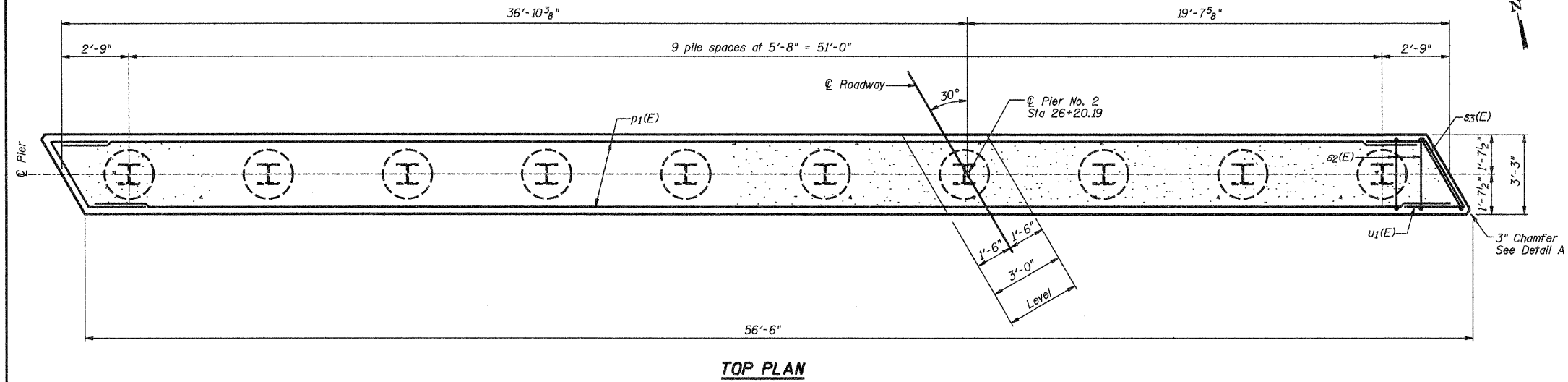

SECTION THRU PIER
(Dimensions at Rt L's)

BILL OF MATERIAL

Bar	No.	Size	Length	Shape
p1(E)	18	#7	30'-8"	—
s2(E)	58	#4	11'-11"	□
s3(E)	2	#4	12'-9"	□
u1(E)	8	#6	12'-4"	⌒
Concrete Encasement		Cu Yd	12.5	
Concrete Structures		Cu Yd	22.1	
Reinforcement Bars, Epoxy Coated		Pound	1690	
Furnishing Steel Piles HP 10x42		Foot	350	
Driving Piles		Foot	350	
Underwater Structure Excavation Protection Location 2		Each	1	

PILE DATA

Type: Steel HP 10x42
 Nominal Required Bearing: 228 kips
 Allowable Resistance Available: 76 kips
 Est. Length: 35'
 No. Production Piles: 10
 No. Test Piles: 0

MIN BAR LAP
#7 bar = 5'-2"

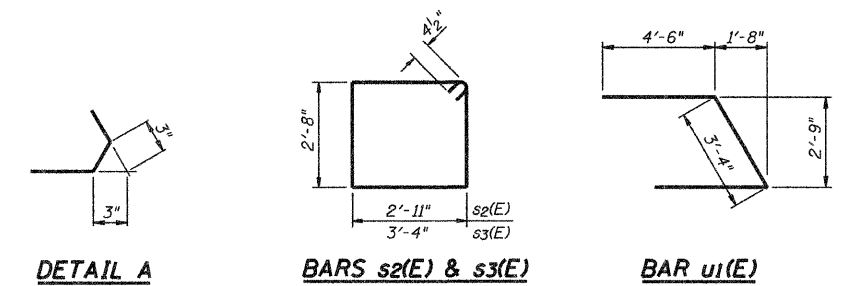

NOTES

The cost of excavation and reinforcement for pile encasement is incidental to the cost of "Concrete Encasement."
 Reinforcement bars designated (E) shall be epoxy coated.

FILE NAME =	USER NAME = rking	DESIGNED ACB	REVISED -		DECATUR (317) 422-8544 CHICAGO (773) 714-0050 ROCKFORD (815) 489-0050 184-001397	PIER NO. 2 DETAILS BALTIMORE AVE (CH 7) OVER FINLEY CREEK			F.A.S. RTE.	SECTION	COUNTY	TOTAL SHEETS	SHEET NO.
In\Municipalities\Macon County\5127 Finley Creek Bridge\CADD_Structural\revised\pier2	DRAWN RLK	REVISED -	CH 7						05-00198-BR	MACON	29	17	
PLOT SCALE = 2/8" = 1' / IN.	CHECKED JMB	REVISED -	CONTRACT NO.										
PLOT DATE = 4/18/2011	DATE 1-11-11	REVISED -	ILLINOIS FED. AID PROJECT										

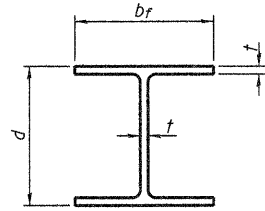

STEEL PILE TABLE

Designation	Depth d	Flange width b _f	Web and Flange thickness t	Encasement diameter A
HP 14x117	14 1/4"	14 7/8"	1 3/16"	30"
x102	14"	14 3/4"	1 1/16"	30"
x89	13 7/8"	14 3/8"	5/8"	30"
x73	13 5/8"	14 5/8"	1/2"	30"
HP 12x84	12 1/4"	12 1/4"	1 1/16"	24"
x74	12 1/8"	12 1/4"	5/8"	24"
x63	12"	12 1/8"	1/2"	24"
x53	11 3/4"	12"	7/16"	24"
HP 10x57	10"	10 1/4"	9/16"	24"
x42	9 3/4"	10 1/8"	7/16"	24"
HP 8x36	8"	8 1/8"	7/16"	18"

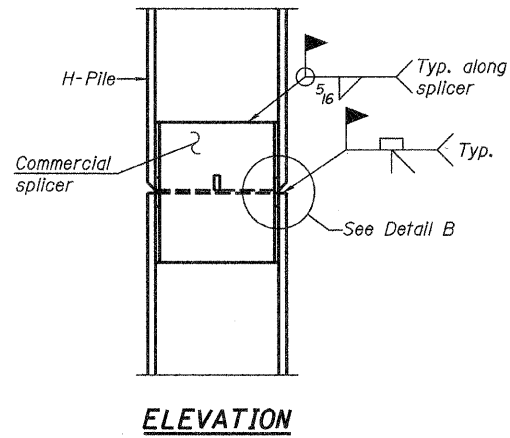

ELEVATION

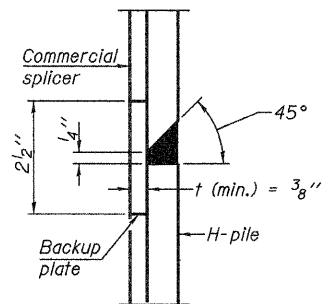

DETAIL "B"

WELDED COMMERCIAL SPLICE

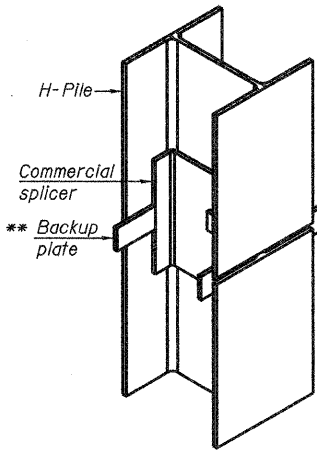

ISOMETRIC VIEW

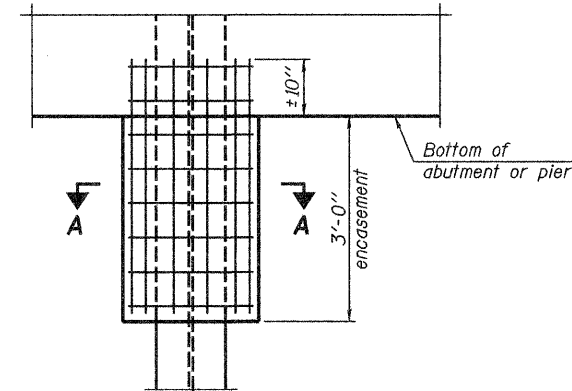

ELEVATION

PILE ENCASEMENT

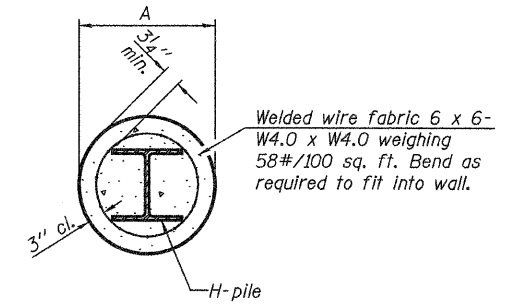

SECTION A-A

Note:
Forms for encasement may be omitted when soil conditions permit.

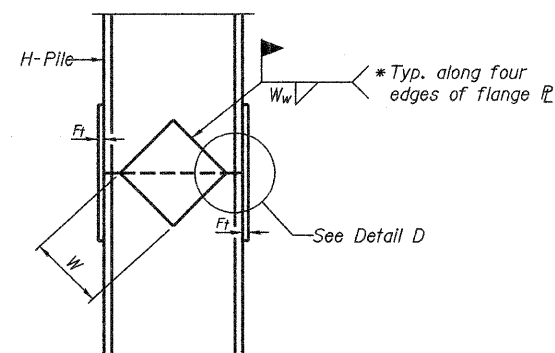

ELEVATION

WELDED PLATE FIELD SPLICE

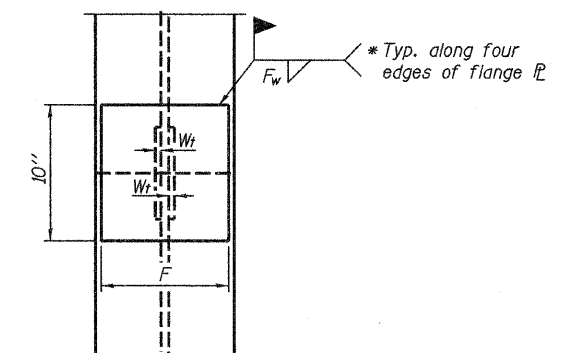

END VIEW

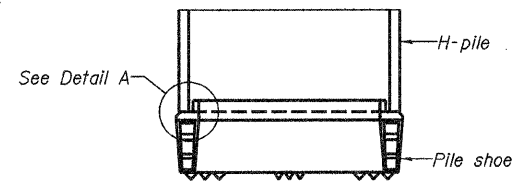

ELEVATION

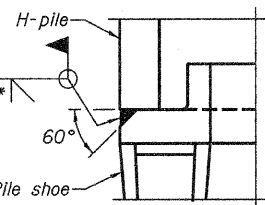

DETAIL A

H-PILE SHOE ATTACHMENT

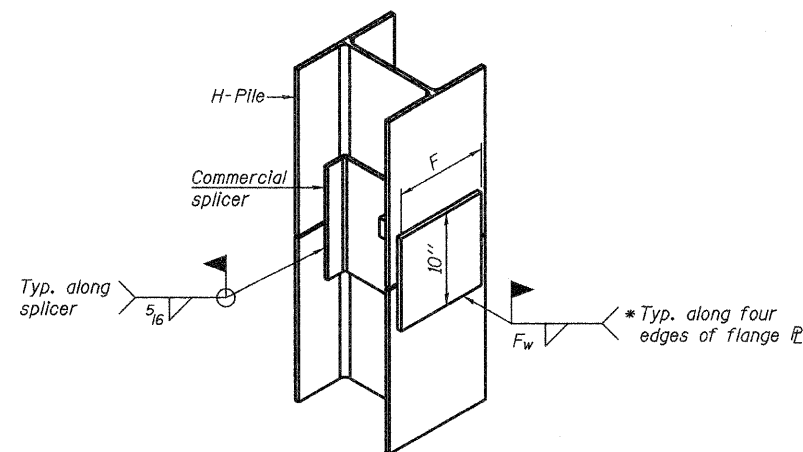

ISOMETRIC VIEW

WELDED COMMERCIAL SPLICE ALTERNATE

- * Interrupt welds 1/4" from end of web and/or each flange.
- ** Remove portions of backup plates that extend outside the flanges.
- *** Weld size per pile shoe manufacturer (5/16" min.).

Note:
The steel H-piles shall be according to AASHTO M270 Grade 50.

Designation	F	F _t	F _w	W	W _t	W _w
HP 14x117	12 1/2"	1"	7/8"	7 3/4"	5/8"	1/2"
x102	12 1/2"	7/8"	3/4"	7 3/4"	5/8"	1/2"
x89	12 1/2"	3/4"	1/16"	7 3/4"	5/8"	1/2"
x73	12 1/2"	5/8"	9/16"	7 3/4"	5/8"	1/2"
HP 12x84	10"	7/8"	1/16"	6 1/2"	5/8"	1/2"
x74	10"	7/8"	1/16"	6 1/2"	5/8"	1/2"
x63	10"	5/8"	1/2"	6 1/2"	1/2"	3/8"
x53	10"	5/8"	1/2"	6 1/2"	1/2"	3/8"
HP 10x57	8"	3/4"	9/16"	5 1/4"	1/2"	3/8"
x42	8"	5/8"	9/16"	5 1/4"	1/2"	3/8"
HP 8x36	7"	5/8"	7/16"	4 1/4"	1/2"	3/8"

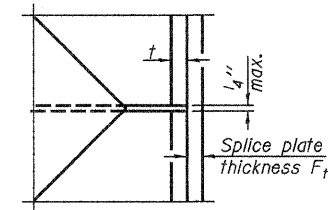

DETAIL D

F-HP

7-1-10

FILE NAME =	USER NAME = #USER*	DESIGNED ACB	REVISED -		DECATUR (317) 422-6544 CHICAGO (773) 714-0050 ROCKFORD (815) 489-0050 184-001997	HP PILE DETAILS BALTIMORE AVE (CH 7) OVER FINLEY CREEK			F.A.S. RTE.	SECTION	COUNTY	TOTAL SHEETS	SHEET NO.
#FILE#		DRAWN RLK	REVISED -			CH 7	05-00198-BR	MACON	29	18			
PLOT SCALE = #SCALE*		CHECKED JMB	REVISED -			CONTRACT NO.							
PLOT DATE = #DATE*		DATE 1-11-11	REVISED -			ILLINOIS FED. AID PROJECT							
SCALE:		SHEET NO. 12 OF 12 SHEETS		STA.		TO STA.							

ROUTE NO.	SECTION	COUNTY	TOTAL SHEETS	SHEET NO.
CH 7	*	MACON	29	19
STA. 24+00.00		TO STA. 24+05.21		
FED. RD. DIST. NO. 7	ILLINOIS	PROJECT		
* 05-00198-06-BR				

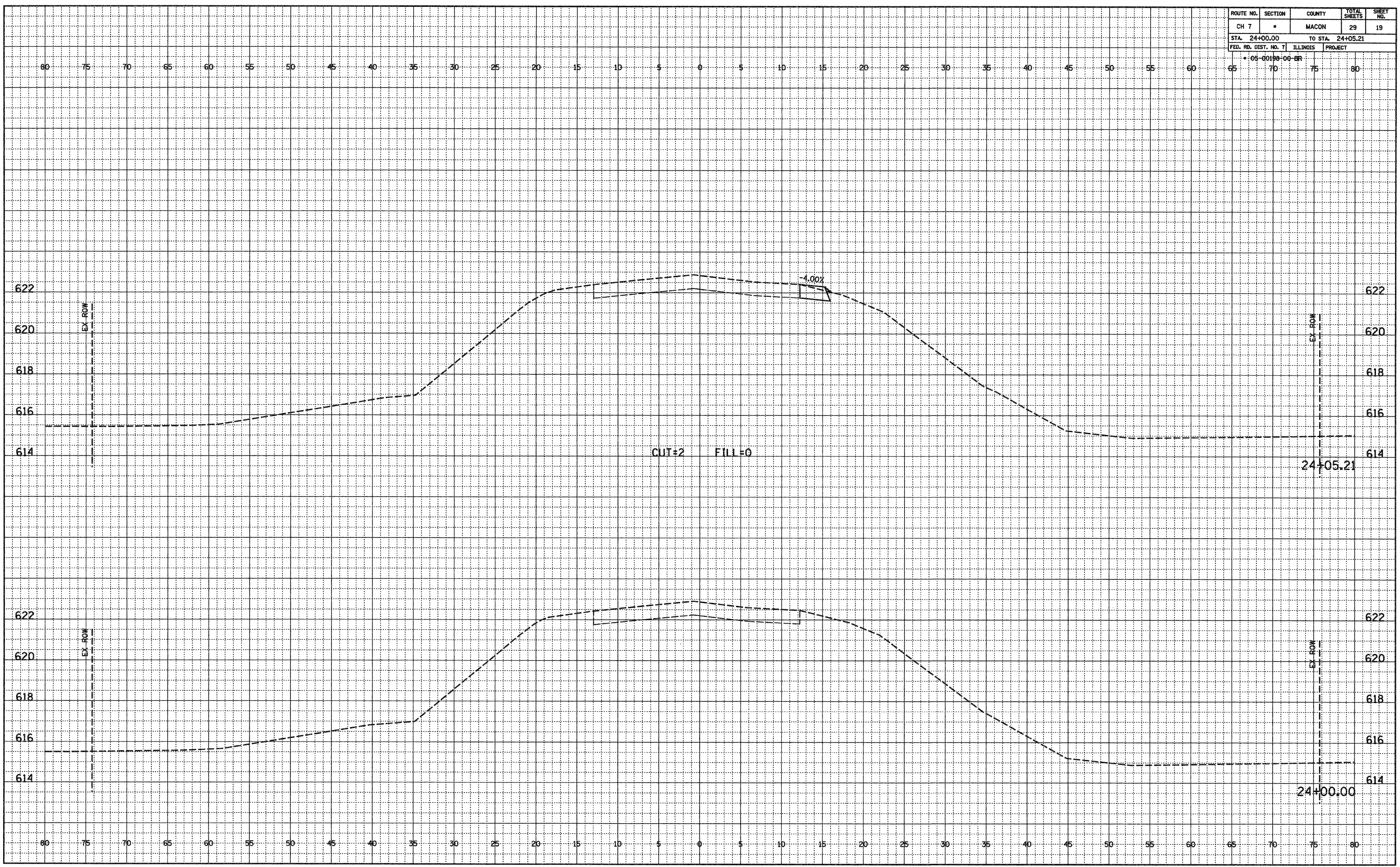

FINAL	SURVEYED	BY	DATE
NO.	NOTEBOOK		
	NO.		

ORIGINAL	SURVEYED	BY	DATE
NO.	NOTEBOOK		
	NO.		

CH 7 CROSS SECTIONS

ROUTE NO.	SECTION	COUNTY	TOTAL SHEETS	SHEET NO.
CH 7	*	MACON	29	20
STA. 24+28.19		TO STA. 24+50.00		
FED. RD. DIST. NO. 7	ILLINOIS	PROJECT		
* 05-00188-06-BR				

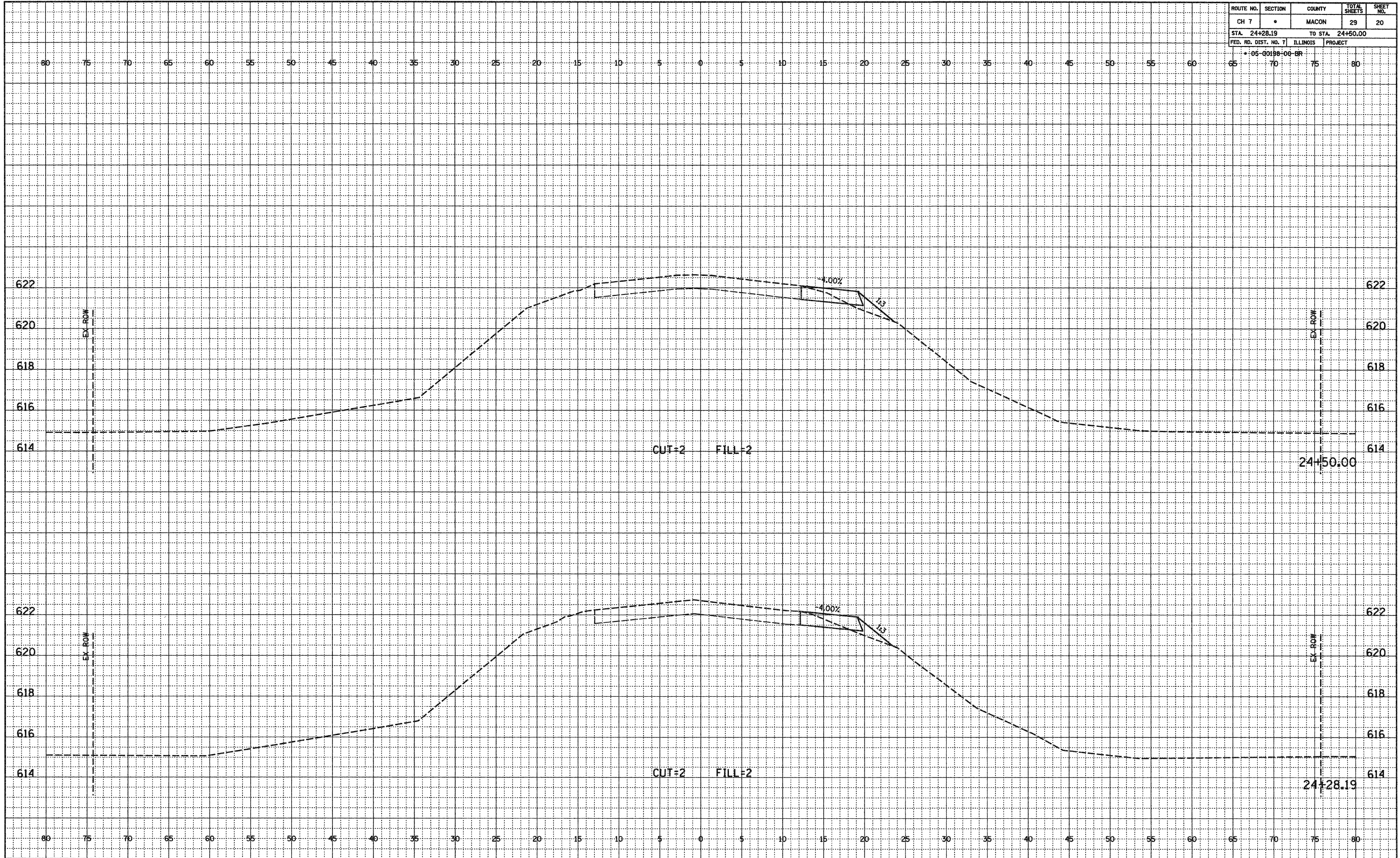

FINAL	SURVEYED	BY	DATE
NOTEBOOK	PLOTTED		
NO. _____	NO. _____		

ORIGINAL	SURVEYED	BY	DATE
NOTEBOOK	PLOTTED		
NO. _____	NO. _____		

CH 7 CROSS SECTIONS

ROUTE NO.	SECTION	COUNTY	TOTAL SHEETS	SHEET NO.
CH 7		MACON	29	21
STA. 25+00.00		TO STA. 25+28.50		
FED. RD. DIST. NO. 7		ILLINOIS PROJECT		
05-00198-06-BR				

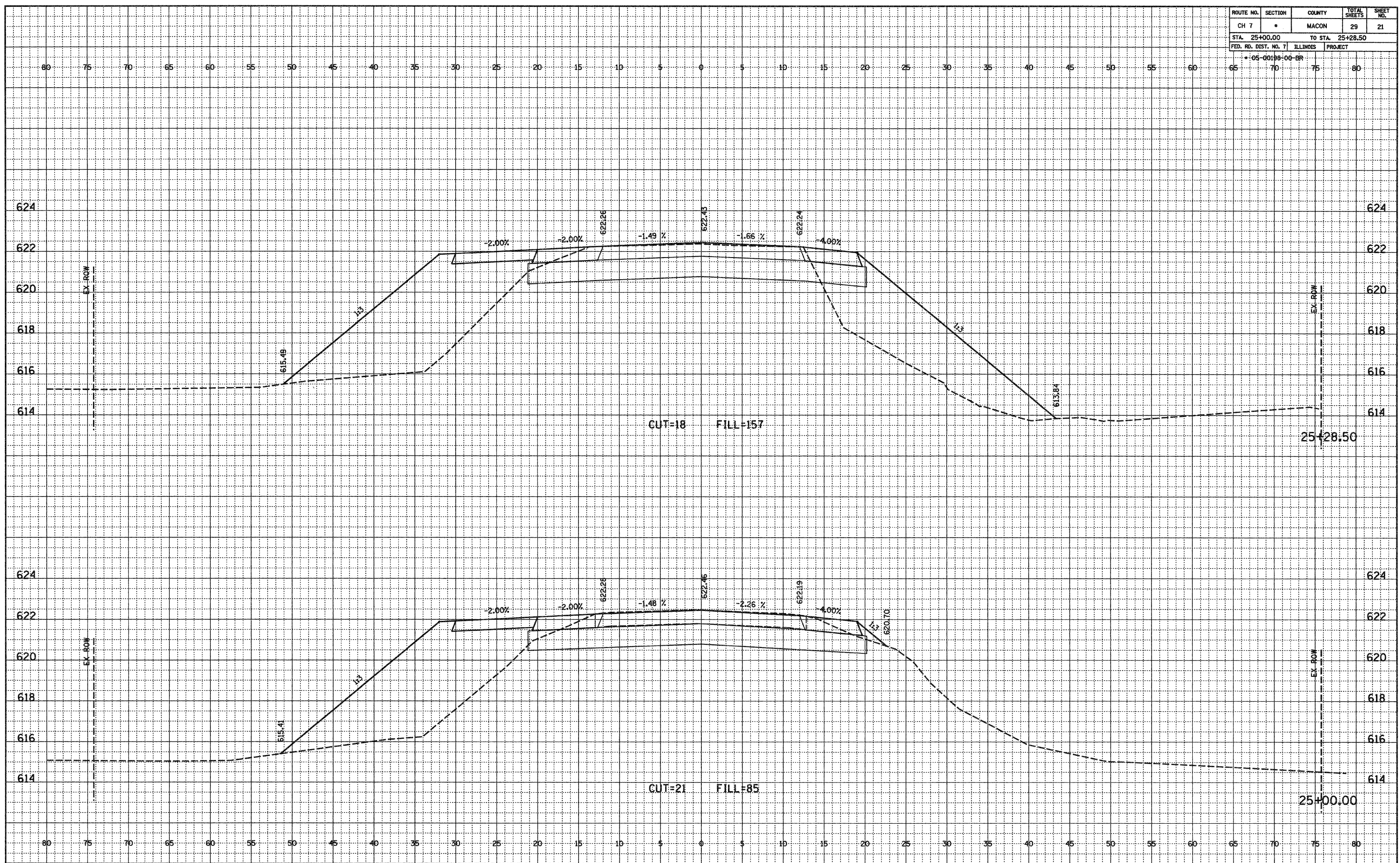

CH 7 CROSS SECTIONS

FINAL SURVEYED
 PLOTTED
 NOTEBOOK ALIGNMENT CHECKED
 NO. OF WRT CHECKED

ORIGINAL SURVEYED
 PLOTTED
 NOTEBOOK GRADES CHECKED
 STRUCTURE NOTATIONS OK'D

ROUTE NO.	SECTION	COUNTY	TOTAL SHEETS	SHEET NO.
CH 7		MACON	29	22
STA. 25+46.40		TO STA. 25+55.97		
FED. RD. DIST. NO. 7		ILLINOIS PROJECT		
05-G0180-06-BR				

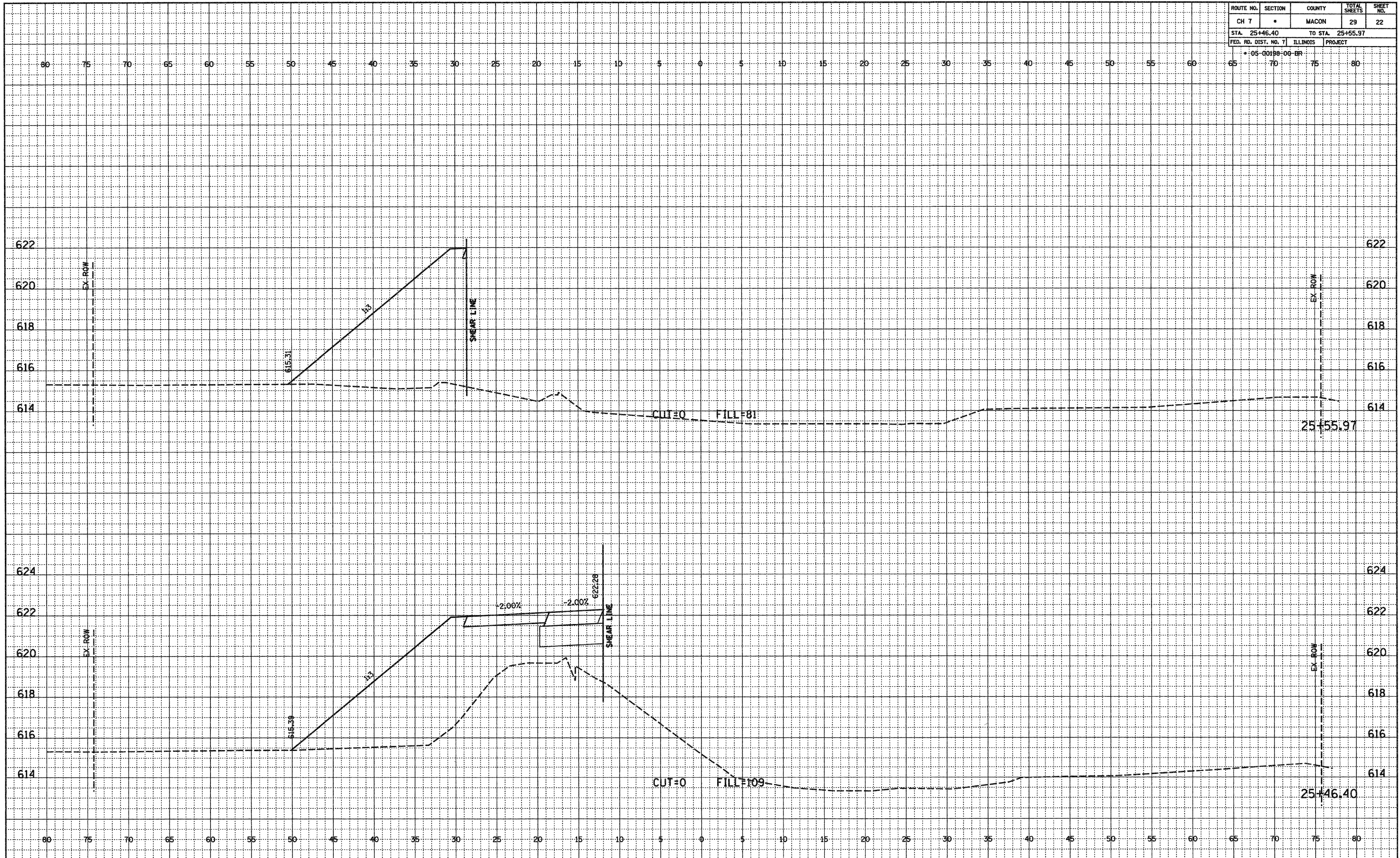

CH 7 CROSS SECTIONS

FINAL SURVEYED
 PLOTTED
 NOTEBOOK GRADES CHECKED
 NO. _____ DATE _____

ORIGINAL SURVEYED
 PLOTTED
 NOTEBOOK GRADES CHECKED
 NO. _____ DATE _____

ROUTE NO.	SECTION	COUNTY	TOTAL SHEETS	SHEET NO.
CH 7	*	MACON	29	23
STA. 26+51.68		TO STA. 26+51.68		
FED. RD. DIST. NO. 7	ILLINOIS	PROJECT		
* 05-00188-00-BR				

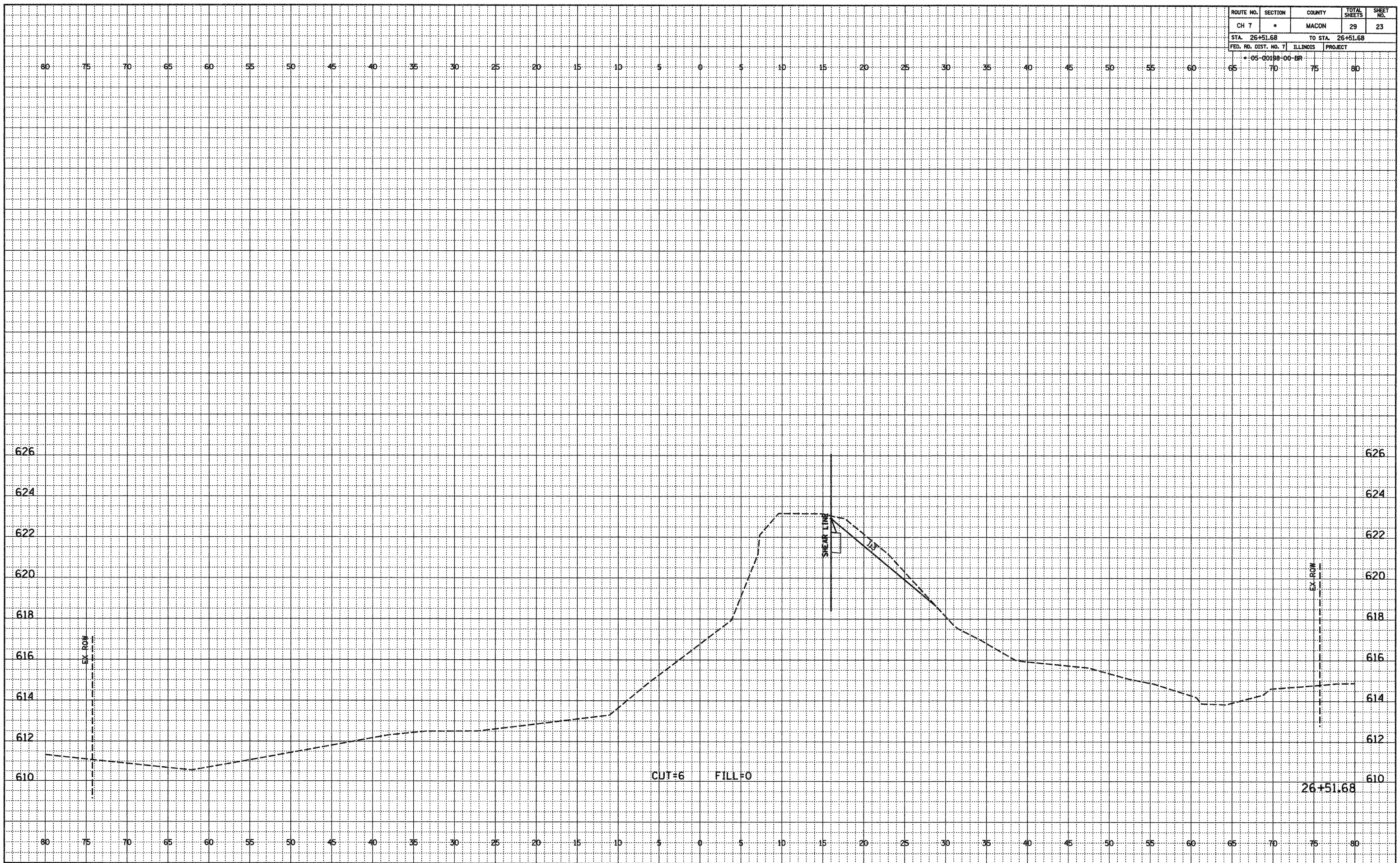

FINAL	SURVEYED	BY	DATE
NOTEBOOK	PLOTTED		
NO.	BY		

ORIGINAL	SURVEYED	BY	DATE
NOTEBOOK	PLOTTED		
NO.	BY		

CH 7 CROSS SECTIONS

ROUTE NO.	SECTION	COUNTY	TOTAL SHEETS	SHEET NO.
CH 7	*	MACON	29	24
STA. 26+67.84		TO STA. 26+67.84		
FED. RD. DIST. NO. 7	ILLINOIS	PROJECT		
* 05-00198-00-BR				

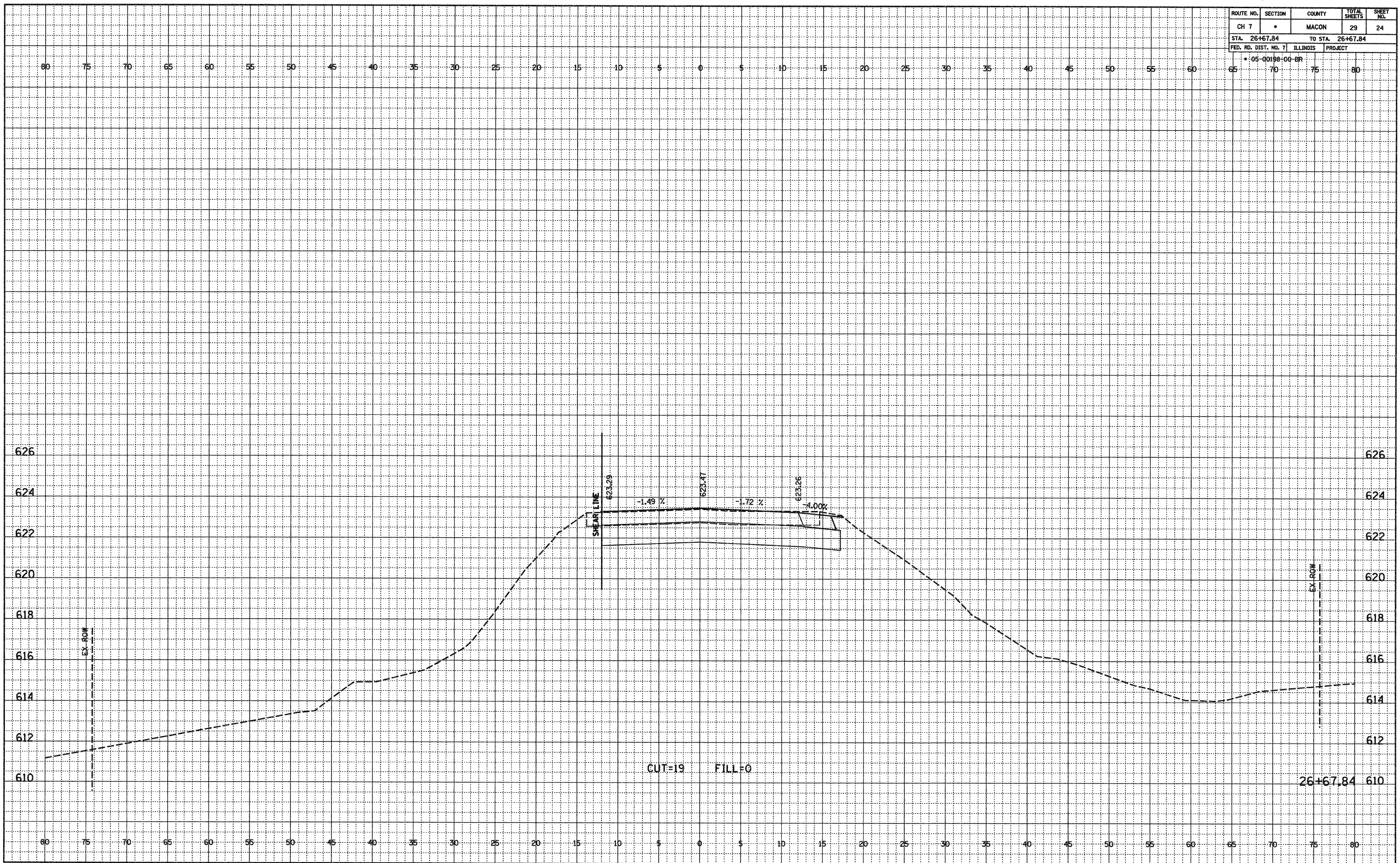

FINAL	DATE
SURVEYED	
PLOTTED	
REVISIONS	
NO. OF REV. DESIG.	
NO.	

ORIGINAL	DATE
SURVEYED	
PLOTTED	
REVISIONS	
NO. OF REV. DESIG.	
NO.	

CH 7 CROSS SECTIONS

ROUTE NO.	SECTION	COUNTY	TOTAL SHEETS	SHEET NO.
CH 7		MACON	29	25
STA. 26+77.42		TO STA. 26+86.93		
FED. RD. DIST. NO. 7	ILLINOIS	PROJECT		
05-00198-06-BR				

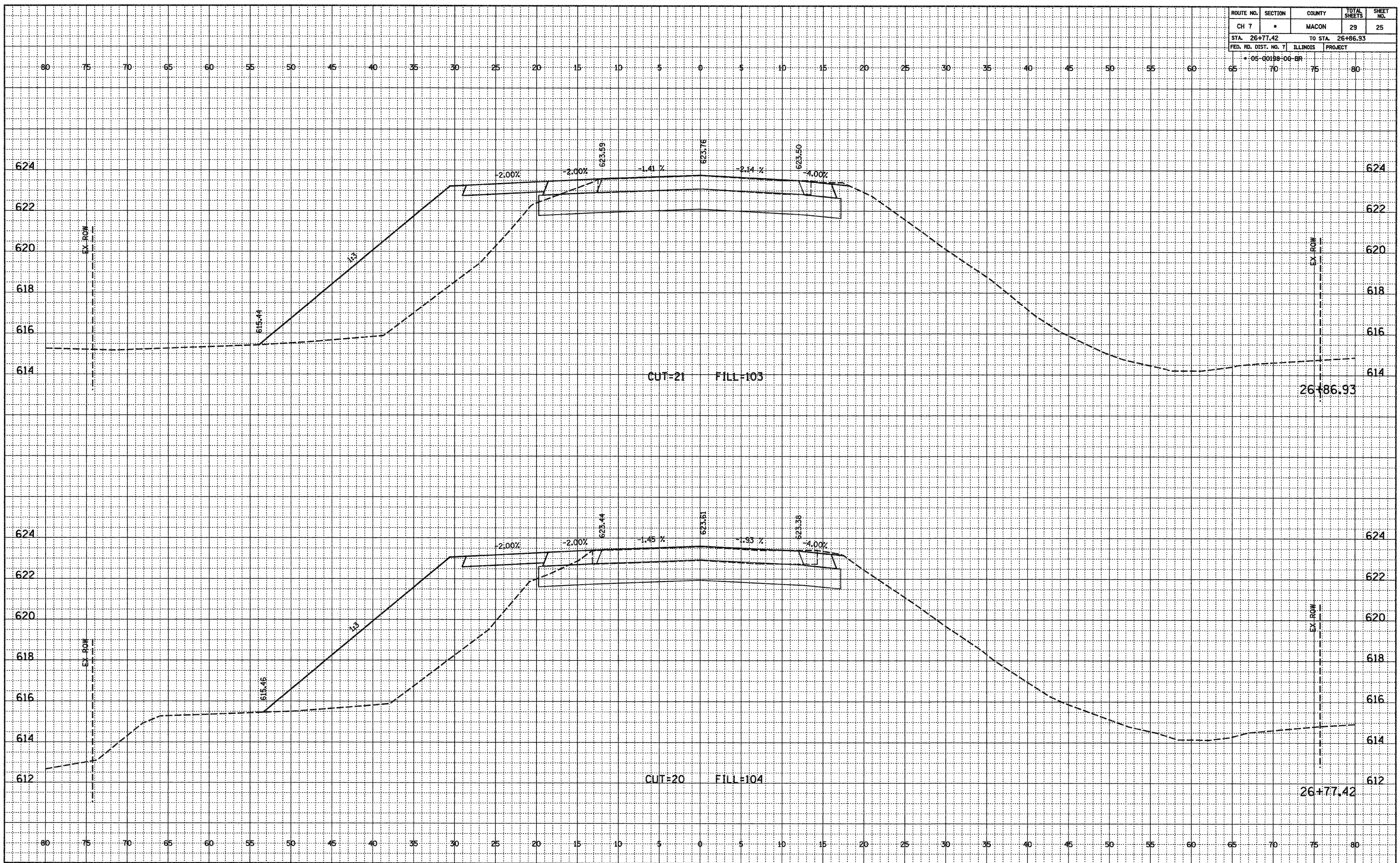

FINAL SURVEYED BY DATE
 PLOTTED BY DATE
 NOTEBOOK NO. OF MAN CHECKED

ORIGINAL SURVEYED BY DATE
 PLOTTED BY DATE
 NOTEBOOK NO. STRUCTURE NOTATIONS OK'D

CH 7 CROSS SECTIONS

ROUTE NO.	SECTION	COUNTY	TOTAL SHEETS	SHEET NO.
CH 7	*	MACON	29	26
STA. 27+00.00		TO STA. 27+08.50		
FED. RD. DIST. NO. 7		ILLINOIS PROJECT		
* 05-00198-00-BR				

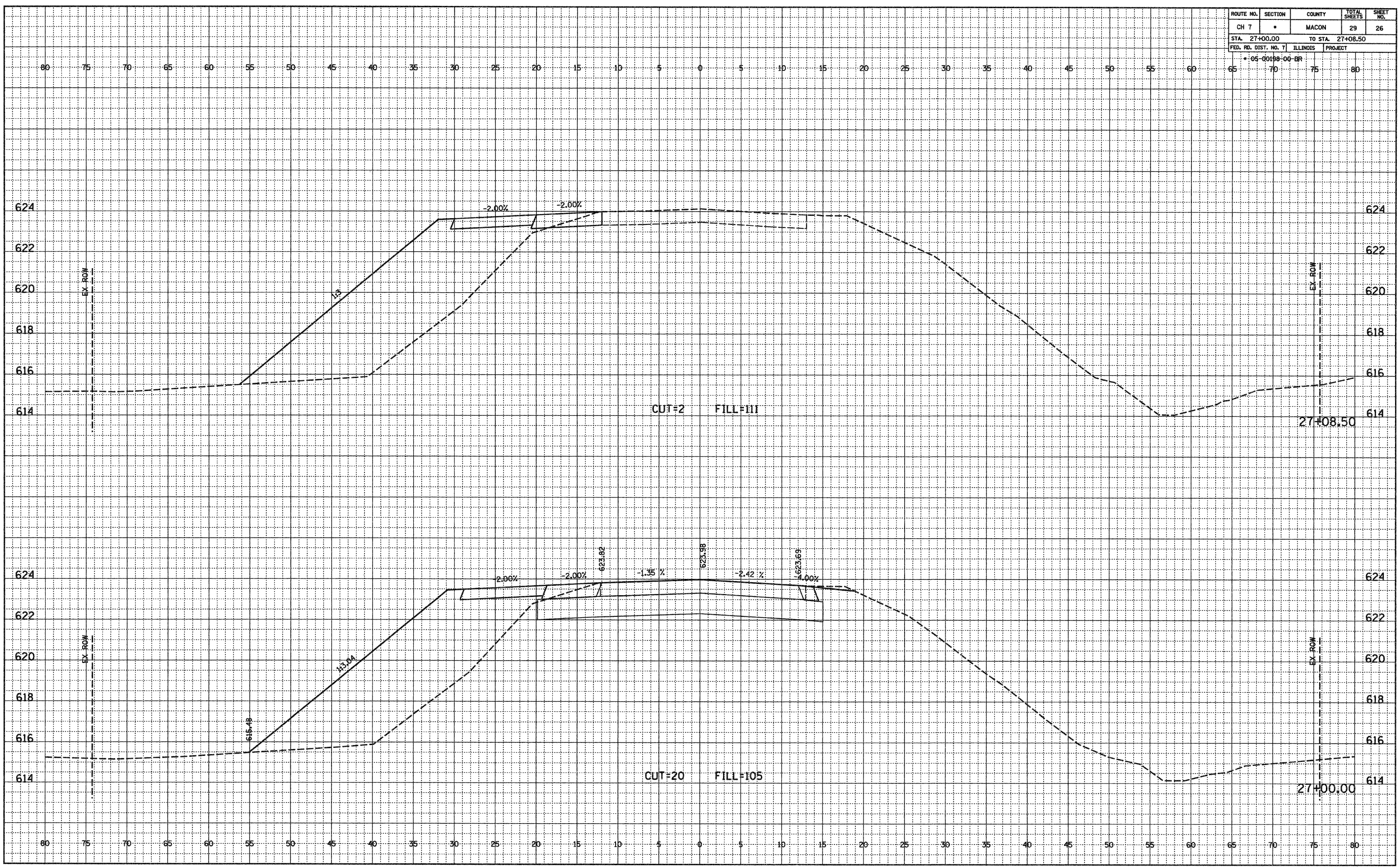

FINAL SURVEYED BY DATE
 PLOTTED BY
 NOTEBOOK NO. _____
 DATE CHECKED _____
 BY: _____

ORIGINAL SURVEYED BY DATE
 PLOTTED BY
 NOTEBOOK NO. _____
 DATE CHECKED _____
 BY: _____
 STRUCTURE NOTATIONS OK'D

CH 7 CROSS SECTIONS

ROUTE NO.	SECTION	COUNTY	TOTAL SHEETS	SHEET NO.
CH 7	*	MACON	29	27
STA. 27+62.20		TO STA. 27+62.20		
FED. RD. DIST. NO. 7		ILLINOIS PROJECT		
* 05-00180-00-BR				

FINAL	SURVEYED	BY	DATE
NOTEBOOK	PLOTTED		
NO.	NO.		

ORIGINAL	SURVEYED	BY	DATE
NOTEBOOK	PLOTTED		
NO.	NO.		

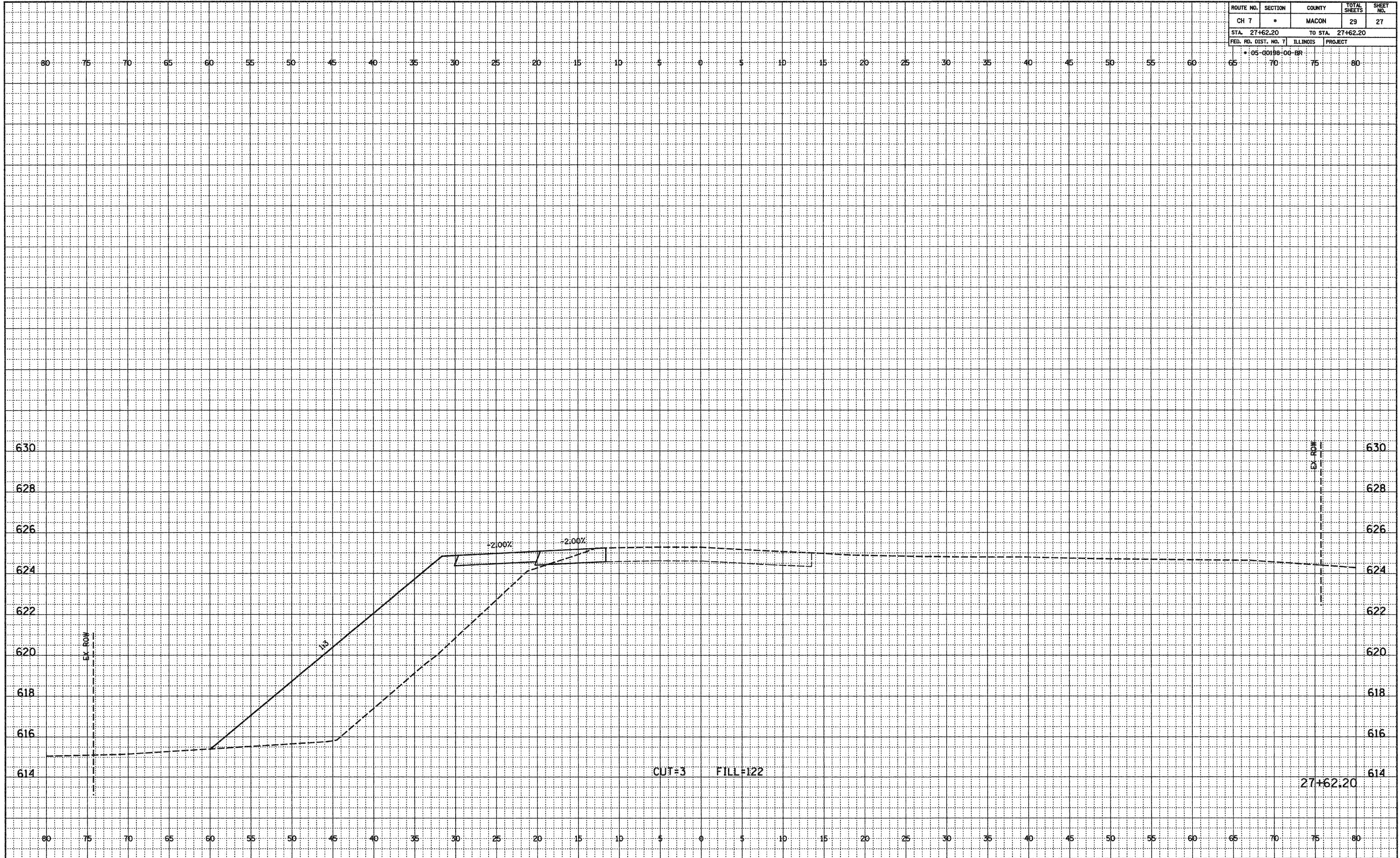

CH 7 CROSS SECTIONS

ROUTE NO.	SECTION	COUNTY	TOTAL SHEETS	SHEET NO.
CH 7	*	MACON	29	28
STA. 27+72.20		TO STA. 27+72.20		
FED. RD. DIST. NO. 7		ILLINOIS PROJECT		
* 05-00180-00-BR				

FINAL	SURVEYED	BY	DATE
NOTEBOOK	PLOTTED		
NO.	BY		
	NO. OF PAGES		

ORIGINAL	SURVEYED	BY	DATE
NOTEBOOK	PLOTTED		
NO.	BY		
	NO. OF PAGES		
	STRUCTURE NOTATIONS GRID		

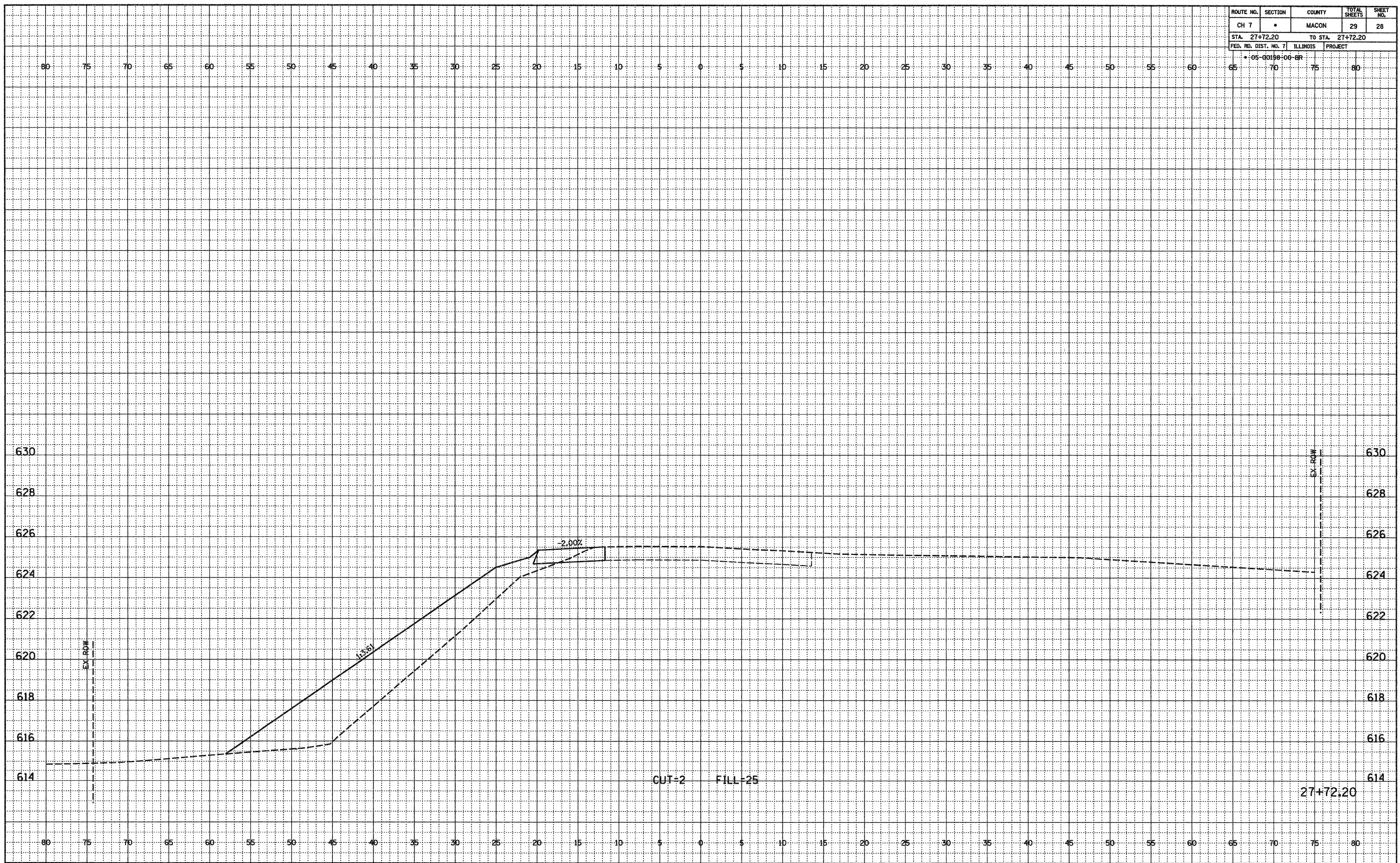

CH 7 CROSS SECTIONS

ROUTE NO.	SECTION	COUNTY	TOTAL SHEETS	SHEET NO.
CH 7	*	MACON	29	29
STA. 28+00.00		TO STA. 28+50.00		
FED. RD. DIST. NO. 7		ILLINOIS PROJECT		

05-00188-06-BR



CH 7 CROSS SECTIONS

FINAL	SURVEYED	DATE
NOTEBOOK	PLOTTED	
NO.	ALIGNED	
	BY	
	DATE	

ORIGINAL	SURVEYED	DATE
NOTEBOOK	PLOTTED	
NO.	GRADES CHECKED	
	STRUCTURE NOTATIONS OK'D	
	BY	
	DATE	