

ROUTE NO.	SECTION	COUNTY	TOTAL SHEETS	SHEET NO.
FAU 8390	04-00084-01-FV	EFFINGHAM	139	7
FED. ROAD DIST. NO. 7		ILLINOIS		

CONTRACT #95639

PAVING LEGEND

- ① HOT-MIX ASPHALT SURFACE COURSE, MIX "C", N70, 1 3/4"
- ② HOT-MIX ASPHALT BINDER COURSE, IL-19.0, N70, 1 3/4"
- ③ HOT-MIX ASPHALT BINDER COURSE, IL-19.0, N70, 1 3/4"
- ④ 10" SOIL CEMENT BASE COURSE, CONSIST OF 5" AGGREGATE BASE COURSE, TYPE A AND 5" OF SOIL ALL MIXED WITH 12% CEMENT (BY VOLUME)
- ⑤ HOT-MIX ASPHALT SURFACE COURSE, MIX "C", N70, 1 3/4"
- ⑥ AGGREGATE BASE COURSE, TYPE A, 8"

Revised 5-31-2011

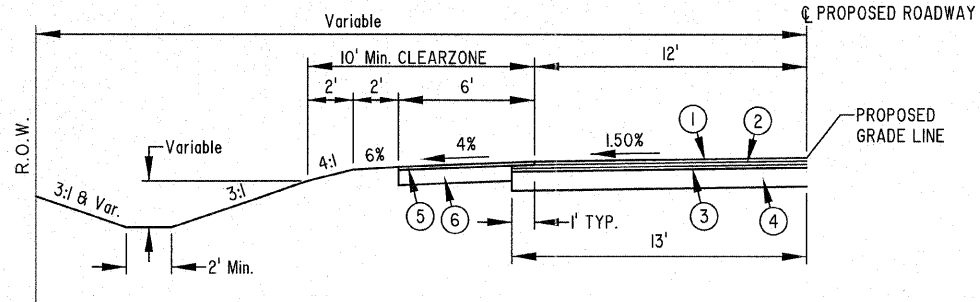

TYPICAL SECTION - EVERGREEN AVENUE

LT STA. 32+63.87 TO STA. 34+96.43
LT STA. 37+00.00 TO STA. 38+76.00

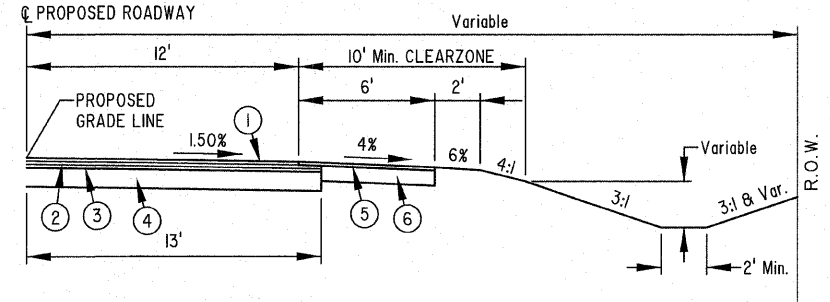

TYPICAL SECTION - EVERGREEN AVENUE

RT STA. 32+63.87 TO STA. 33+50.00
RT STA. 37+88.65 TO STA. 38+76.00

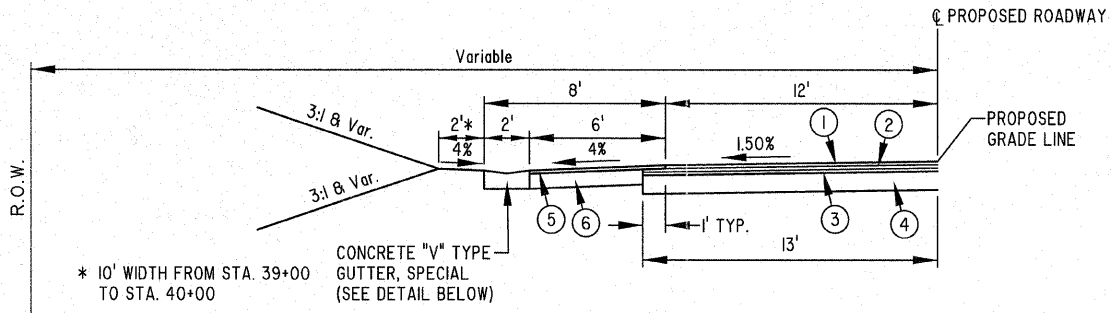

TYPICAL SECTION - EVERGREEN AVENUE

LT STA. 34+96.43 TO STA. 37+00.00
LT STA. 38+76.00 TO STA. 41+12.40

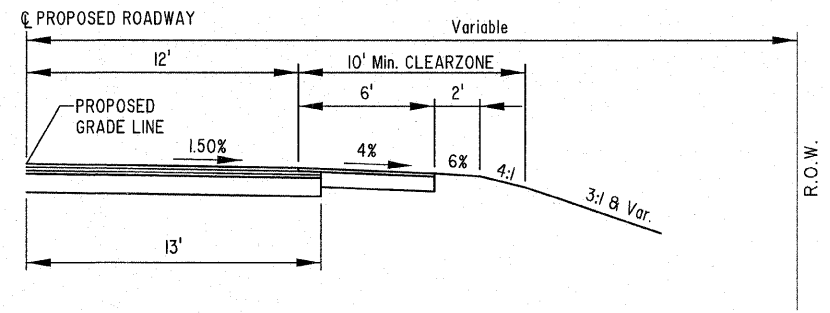

TYPICAL SECTION - EVERGREEN AVENUE

RT STA. 33+50.00 TO STA. 37+88.65

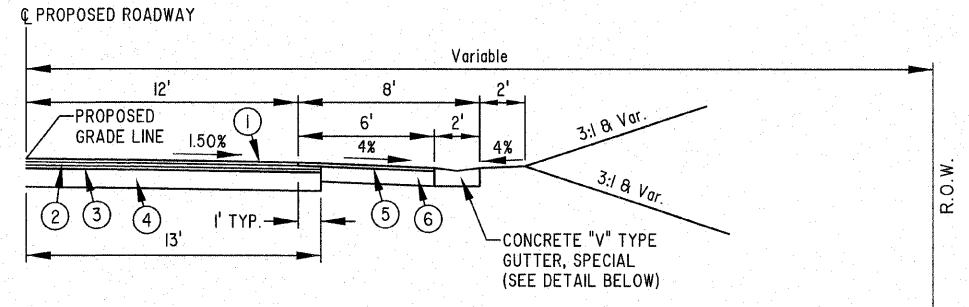

TYPICAL SECTION - EVERGREEN AVENUE

RT STA. 38+76.00 TO STA. 41+12.40

STA. 32+63.87 TO STA. 41+12.40

	MILANO & GRUNLOH ENGINEERS, LLC	TYPICAL SECTIONS
	14 WEST WASHINGTON P.O. BOX 937 EFFINGHAM, ILLINOIS 62401	EVERGREEN AVENUE
	PHONE: (217) 347-7262 (800) 677-2714 FAX #: (217) 342-3433	COUNTY OF EFFINGHAM, ILLINOIS
	File name: S:\DWB\05\08227\dwg\Typical.dwg Plot date: 02/08/11 09:00	