

F.A.I. RTE.	SECTION	COUNTY	TOTAL SHEETS	SHEET NO.
9266	06-00062-06-PV	ST. CLAIR	80	7
FHWA REG. NO. 7	ILLINOIS	PROJECT NO.	RS-0163(035)	
FEDERAL AID PROJECT		CONTRACT NO.	97457	

TYPICAL SECTIONS

LEGEND

- ① PROPOSED HOT-MIX ASPHALT PAVEMENT (FULL DEPTH), 11" (2" SURFACE WITH 9" BINDER)
- ② PROPOSED AGGREGATE BASE COURSE, TYPE A 8"
- ③ PROPOSED COMBINATION CONCRETE CURB AND GUTTER, TYPE B-6.24
- ④ PROPOSED PORTLAND CEMENT CONCRETE SIDEWALK, 4" STA. 3+30.00 TO 18+40.00
- ⑤ PROPOSED HOT-MIX ASPHALT SHOULDERS, 8"
- ⑥ PROPOSED 4 1/4" HOT-MIX ASPHALT BINDER COURSE, IL-19.0, N70. LEVELING BINDER AS REQUIRED TO GENERATE PROPER CROSS SLOPE
- ⑦ EXISTING 1 1/2" BITUMINOUS CONCRETE BINDER COURSE
EXISTING 1 1/2" BITUMINOUS CONCRETE SURFACE COURSE
- ⑧ EXISTING 8" STABILIZED BASE COURSE
- ⑨ EXISTING 4" SUB-BASE GRANULAR MATERIAL
- ⑩ EXISTING 8" STABILIZED SHOULDERS
- ⑪ EXISTING AGGREGATE SHOULDERS
- ⑫ INTENTIONALLY LEFT BLANK
- ⑬ PROPOSED CONCRETE GUTTER, TYPE A
- ⑭ EXISTING 2" OIL AND CHIP
- ⑮ EXISTING 6" COMPACTED GRAVEL BASE COURSE
- ⑯ EXISTING 4" CRUSHED STONE BASE COURSE
- ⑰ PROPOSED AGGREGATE WEDGE SHOULDER, TYPE B
- ⑱ PROPOSED 2" HOT-MIX ASPHALT SURFACE COURSE, MIX "D" N70
- ⑲ EXISTING CONCRETE SIDEWALK
- ⑳ PROPOSED GUARDRAIL
- ㉑ EXISTING GUARDRAIL
- ㉒ REERECTED EXISTING GUARDRAIL
- ㉓ EXISTING CONCRETE CURB AND GUTTER
- ㉔ FUTURE CONCRETE SIDEWALK
- ㉕ PROPOSED BITUMINOUS MATERIAL (PRIME COAT)
PROPOSED AGGREGATE (PRIME COAT)
- ㉖ PROPOSED AGGREGATE SHOULDER TYPE A 8"

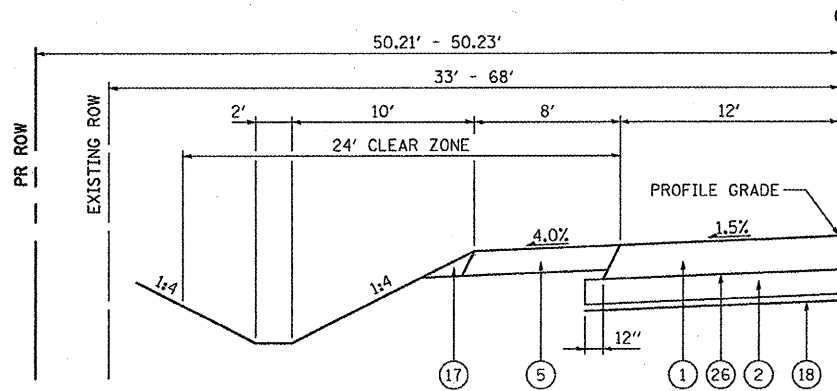

PROPOSED SHILOH CUT-OFF (MAIN STREET)

STA. 49+25.00 TO STA. 50+89.60
STA. 65+91.54 TO STA. 70+71.19
STA. 75+96.69 TO STA. 77+95.00
(NOT TO SCALE)

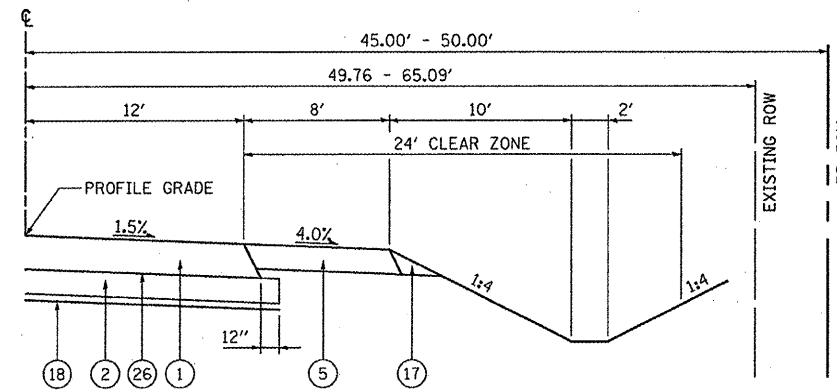

PROPOSED SHILOH CUT-OFF (MAIN STREET)

STA. 49+25.00 TO STA. 50+89.60
STA. 65+91.54 TO STA. 67+38.01
STA. 68+51.08 TO STA. 78+25.00
(NOT TO SCALE)

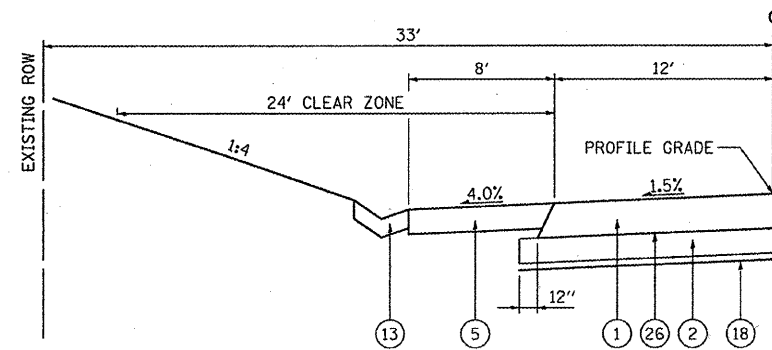

PROPOSED SHILOH CUT-OFF (MAIN STREET)

STA. 77+95.00 TO STA. 81+81.47
(NOT TO SCALE)

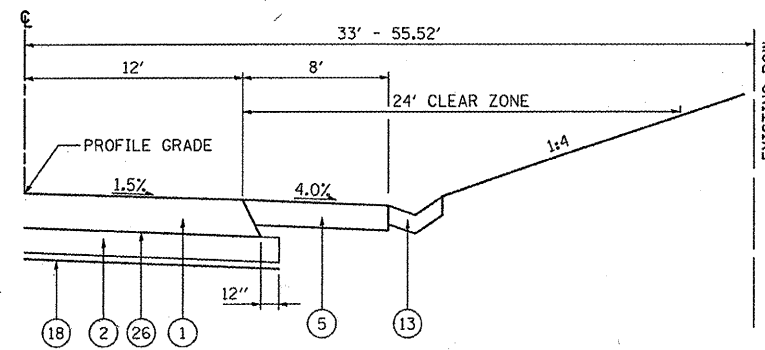

PROPOSED SHILOH CUT-OFF (MAIN STREET)

STA. 67+38.01 TO STA. 68+51.08
STA. 78+25.00 TO STA. 80+39.58
(NOT TO SCALE)

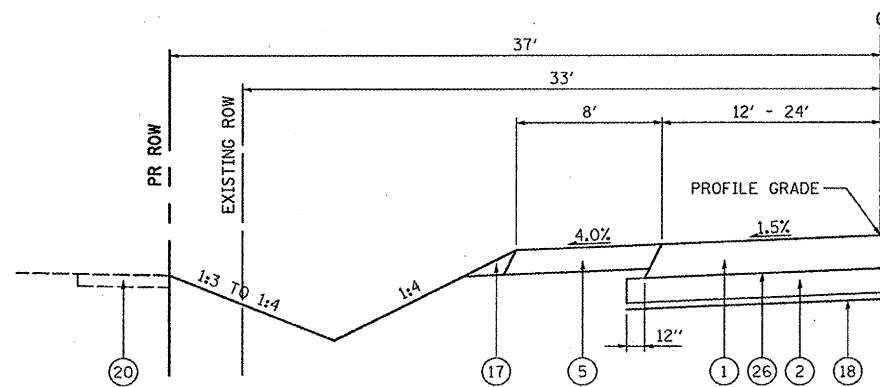

PROPOSED SHILOH CUT-OFF (MAIN STREET)

STA. 70+71.19 TO STA. 75+96.69
(NOT TO SCALE)

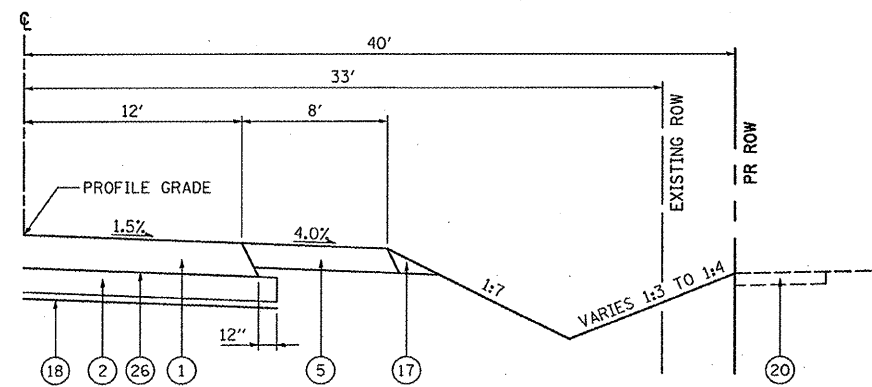

PROPOSED SHILOH CUT-OFF (MAIN STREET)

STA. 80+39.58 TO STA. 81+38.00
(NOT TO SCALE)

CHAD D. FAIRBANKS
062-063136
4-13-11
CAP 11-20-11