

**STEEL PILE TABLE**

Designation	Depth d	Flange width bf	Web and Flange thickness t	Encasement diameter A
HP 14x117	14 1/4"	14 7/8"	13/16"	30"
x102	14"	14 3/4"	1/16"	30"
x89	13 7/8"	14 3/4"	5/8"	30"
x73	13 5/8"	14 5/8"	1/2"	30"
HP 12x84	12 1/4"	12 1/4"	11/16"	24"
x74	12 1/8"	12 1/4"	5/8"	24"
x63	12"	12 1/8"	1/2"	24"
x53	11 3/4"	12"	7/16"	24"
HP 10x57	10"	10 1/4"	9/16"	24"
x42	9 3/4"	10 1/8"	7/16"	24"
HP 8x36	8"	8 1/8"	7/16"	18"

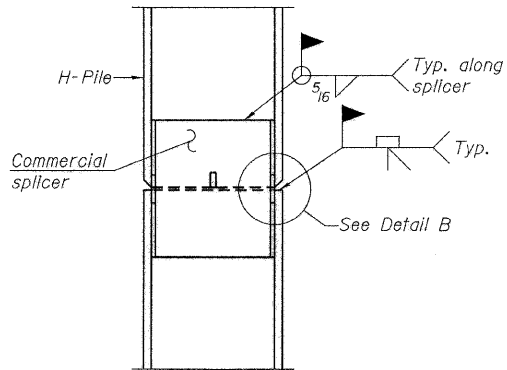

**ELEVATION**

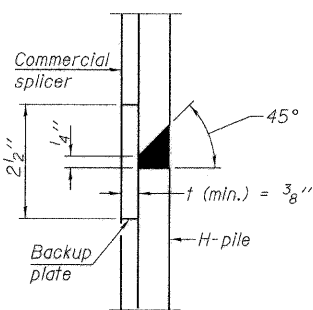

**DETAIL "B"**

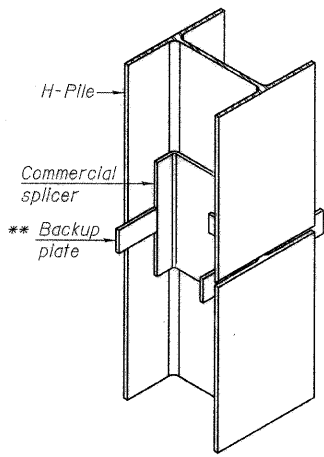

**ISOMETRIC VIEW**

**WELDED COMMERCIAL SPLICE**

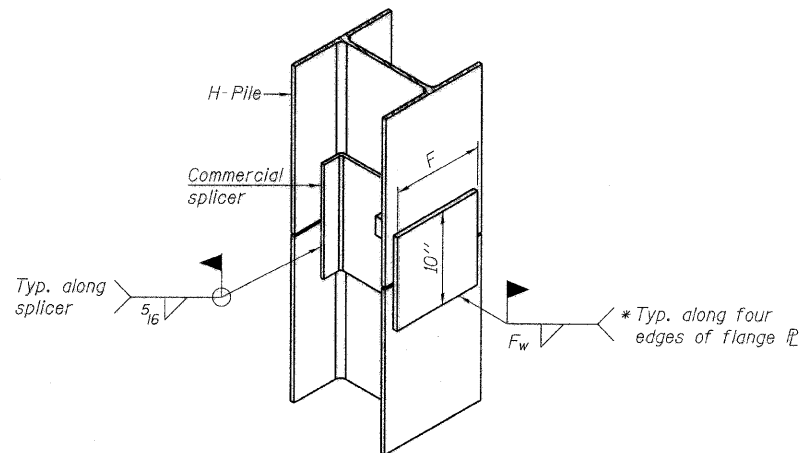

**ISOMETRIC VIEW**

**WELDED COMMERCIAL SPLICE ALTERNATE**

- \* Interrupt welds 1/4" from end of web and/or each flange.
- \*\* Remove portions of backup plates that extend outside the flanges.
- \*\*\* Weld size per pile shoe manufacturer (5/16" min.).

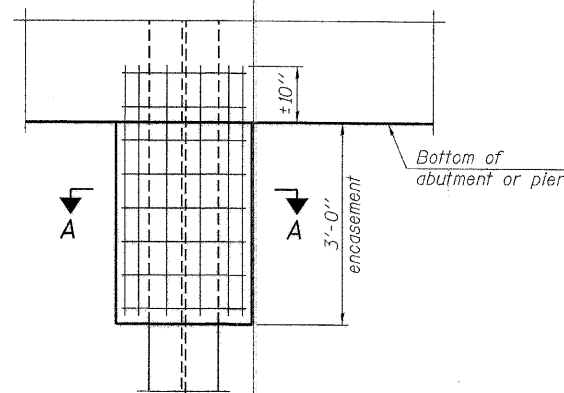

**ELEVATION**

**PILE ENCASEMENT**

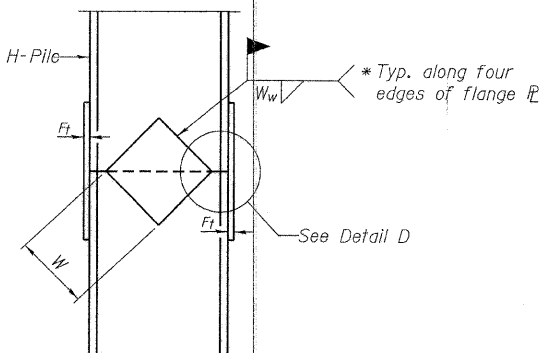

**ELEVATION**

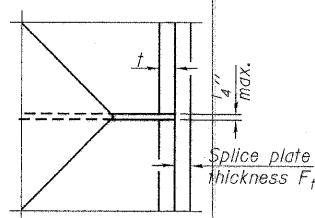

**DETAIL D**

**WELDED PLATE FIELD SPLICE**

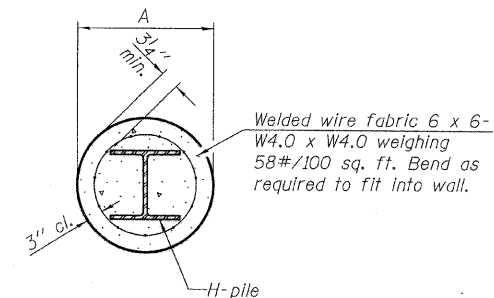

Note:  
Forms for encasement may be omitted when soil conditions permit.

**SECTION A-A**

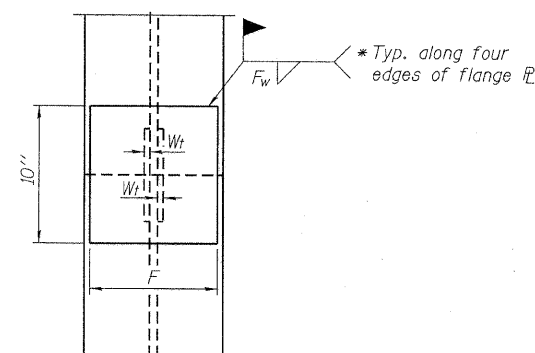

**END VIEW**

Designation	F	Ft	Fw	W	Wt	Ww
HP 14x117	12 1/2"	1"	7/8"	7 3/4"	5/8"	1/2"
x102	12 1/2"	7/8"	3/4"	7 3/4"	5/8"	1/2"
x89	12 1/2"	3/4"	11/16"	7 3/4"	5/8"	1/2"
x73	12 1/2"	5/8"	9/16"	7 3/4"	5/8"	1/2"
HP 12x84	10"	7/8"	11/16"	6 1/2"	5/8"	1/2"
x74	10"	7/8"	11/16"	6 1/2"	5/8"	1/2"
x63	10"	5/8"	1/2"	6 1/2"	1/2"	3/8"
x53	10"	5/8"	1/2"	6 1/2"	1/2"	3/8"
HP 10x57	8"	3/4"	9/16"	5 1/4"	1/2"	3/8"
x42	8"	5/8"	9/16"	5 1/4"	1/2"	3/8"
HP 8x36	7"	5/8"	7/16"	4 1/4"	1/2"	3/8"

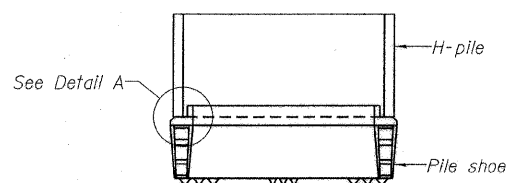

**ELEVATION**

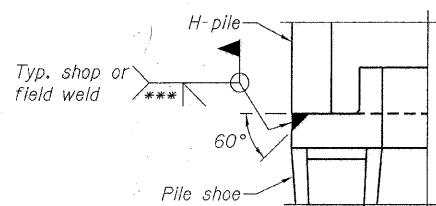

**DETAIL A**

**H-PILE SHOE ATTACHMENT**

Note:  
The steel H-piles shall be according to AASHTO M270 Grade 50.

**HP PILE DETAILS  
STRUCTURE NO. 097-3273**

DESIGNED - A.S.L.
CHECKED - S.W.M.
DRAWN - D.T.M.
CHECKED - S.W.M.

F-HP 11-1-09

**HAMPTON, LENZINI AND RENWICK, INC.**  
 CIVIL ENGINEERS - STRUCTURAL ENGINEERS - LAND SURVEYORS  
 3085 STEVENSON DRIVE, SUITE 201  
 SPRINGFIELD, ILLINOIS 62703  
 217.546.3400 www.hlrengineering.com

SHEET NO. 7  
9 SHEETS

T.R.	SECTION	COUNTY	TOTAL SHEETS	SHEET NO.
28A	07-08137-00-BR	WHITE	13	11
INDIAN CREEK ROAD DISTRICT		CONTRACT NO. 99441		
FED. ROAD DIST. NO.		ILLINOIS FED. AID PROJECT BROS-193(38)		

PROJECT NUMBER: 09 0056 130 DATE: 02/10/11