

STATE OF ILLINOIS  
DEPARTMENT OF TRANSPORTATION

F.A.P. RTE.	SECTION	COUNTY	TOTAL SHEETS	SHEET NO.
330	2021-030-RS	COOK	35	1
		ILLINOIS	CONTRACT NO. 62N43	

D-91-093-21

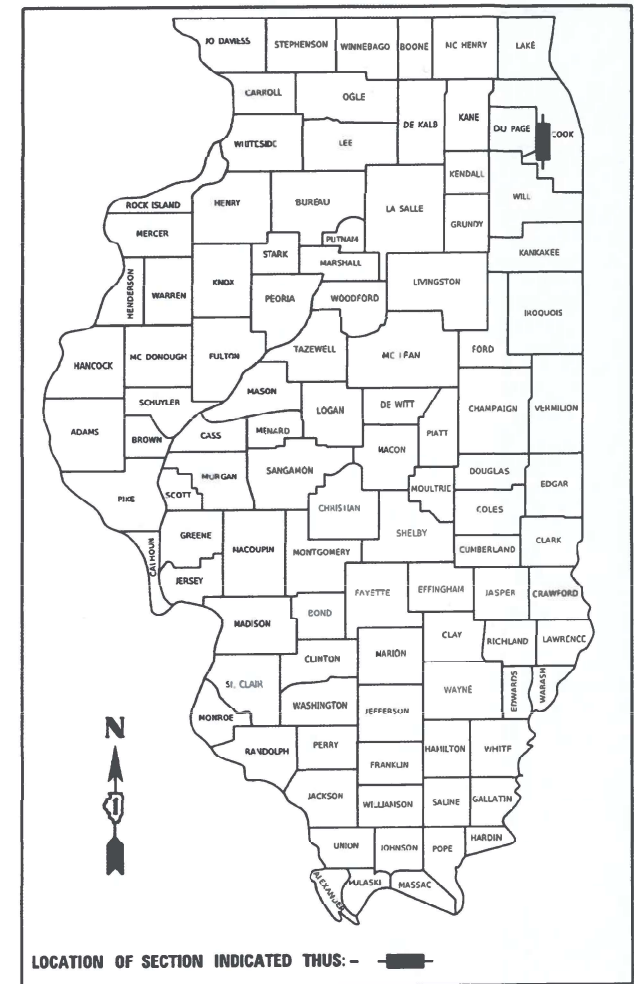

LOCATION OF SECTION INDICATED THIS: -

**PROPOSED  
HIGHWAY PLANS**

**FAP ROUTE 330: US RTE 12/20/45 (LA GRANGE ROAD)  
FROM 31ST ST TO N OF CERMAK RD  
SECTION 2021-030-RS  
PROJECT NHPP-9P76(903)  
SMART OVERLAY AND ADA RAMP IMPROVEMENTS  
COOK COUNTY  
C-91-116-21**

FOR INDEX OF SHEETS, SEE SHEET NO. 2

DESIGN DESIGNATION: OTHER PRINCIPAL ARTERIAL  
FAP ROUTE 330: LA GRANGE ROAD  
2019 ADT: 26,100  
SPEED LIMIT: VARIES 30-40 MPH

THIS PROJECT IS LOCATED IN  
THE VILLAGES OF LA GRANGE PARK  
AND WESTCHESTER

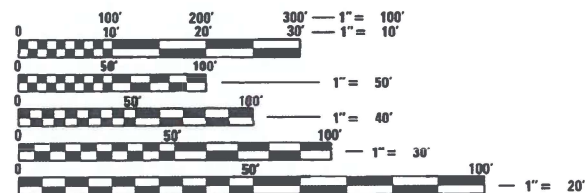

FULL SIZE PLANS HAVE BEEN PREPARED USING STANDARD ENGINEERING SCALES. REDUCED SIZED PLANS WILL NOT CONFORM TO STANDARD SCALES. IN MAKING MEASUREMENTS ON REDUCED PLANS, THE ABOVE SCALES MAY BE USED.

J.U.L.I.E.  
JOINT UTILITY LOCATION INFORMATION FOR EXCAVATORS  
1-800-892-0123  
OR 811

PROJECT ENGINEER MR. DANIEL WILGREEN, P.E. (847) 705-4240  
PROJECT MANAGER MR. FAWAD AQUEEL, P.E., PTOE

CONTRACT NO. 62N43

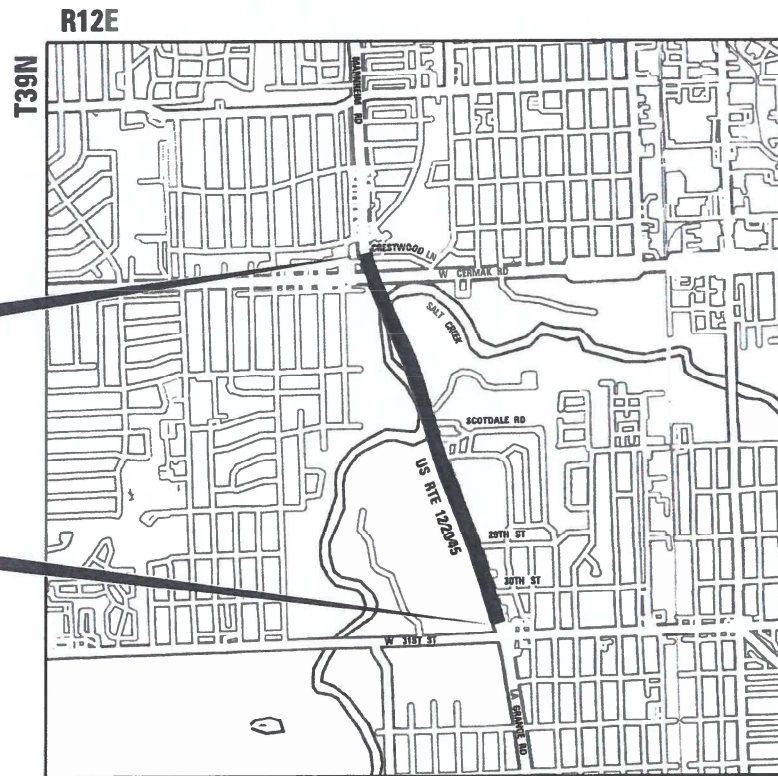

LOCATION MAP (NOT TO SCALE)  
LYONS TOWNSHIP

GROSS LENGTH = 5,908 FT. = 1.118 MILE  
NET LENGTH = 5,908 FT. = 1.118 MILE

PROJECT ENDS  
STA 74 + 95 SB  
STA 75 + 15 NB

RESURFACING OMISSION  
STA 65 + 45 TO  
STA 67 + 49

PROJECT BEGINS  
STA 16 + 07



DATE SIGNED: 03-14-22  
EXP. DATE: 11-30-23  
SHEETS: 1-14

*Jamal Davis*

STATE OF ILLINOIS  
DEPARTMENT OF TRANSPORTATION

SUBMITTED MARCH 16, 2022  
Jose Rios Lara  
REGIONAL ENGINEER

May 13, 2022 [Signature]  
ENGINEER OF DESIGN AND ENVIRONMENT

May 13, 2022 [Signature]  
DIRECTOR OF HIGHWAYS PROJECT IMPLEMENTATION

PRINTED BY THE AUTHORITY  
OF THE STATE OF ILLINOIS

Accurate  
GROUP, INC.

WWW.ACCGI.COM  
101 SCHELTER RD., SUITE B-200  
LINCOLNSHIRE, ILLINOIS 60069  
T (847) 613-1100 F (847) 613-1105  
ILLINOIS PROFESSIONAL DESIGN FIRM NO. 184.002053

## INDEX OF SHEETS

SHEET NO.	DESCRIPTION
1	COVER SHEET
2	INDEX OF SHEETS, STATE HIGHWAY STANDARDS, AND GENERAL NOTES
3-5	SUMMARY OF QUANTITIES
6	ADA CURB RAMP SCHEDULE OF QUANTITIES
7-8	TYPICAL SECTIONS AND DETAILS
9-12	RESURFACING AND PAVEMENT MARKING PLANS
13	ADA CURB RAMP DETAILS
14-17	PROJECT DETAILS FOR ADA CURB RAMP
17-24	DETECTOR LOOP REPLACEMENT AND APS PLANS
25	BD-08 DETAILS FOR FRAMES AND LIDS ADJUSTMENT WITH MILLING
26	BD-22 PAVEMENT PATCHING FOR HMA SURFACED PAVEMENT
27	BD-24 CURB OR CURB AND GUTTER REMOVAL AND REPLACEMENT
28	BD-32 BUTT JOINT AND HMA TAPER DETAILS
29	TC-10 TRAFFIC CONTROL AND PROTECTION FOR SIDE ROADS, INTERSECTIONS, AND DRIVEWAYS
30	TC-11 TYPICAL APPLICATIONS RAISED REFLECTIVE PAVEMENT MARKERS (SNOW-PLOW RESISTANT)
31	TC-13 DISTRICT ONE TYPICAL PAVEMENT MARKINGS
32	TC-14 TRAFFIC CONTROL AND PROTECTION AT TURN BAY (TO REMAIN OPEN TO TRAFFIC)
33	TC-16 SHORT TERM PAVEMENT MARKING LETTERS AND SYMBOLS
34	TC-22 ARTERIAL ROAD INFORMATION SIGN
35	TS-07 DETECTOR LOOP INSTALLATION DETAILS FOR ROADWAY RESURFACING

## LIST OF STATE HIGHWAY STANDARDS

STANDARD NO.	TITLE
000001-08	STANDARD SYMBOLS, ABBREVIATIONS, AND PATTERNS
424001-11	PERPENDICULAR CURB RAMPS FOR SIDEWALKS
424006-05	DIAGONAL CURB RAMPS FOR SIDEWALKS
424011-04	CORNER PARALLEL CURB RAMPS FOR SIDEWALKS
424021-06	DEPRESSED CORNER FOR SIDEWALKS
424026-03	ENTRANCE/ALLEY PEDESTRIAN CROSSINGS
424031-02	MEDIAN PEDESTRIAN CROSSINGS
442201-03	CLASS C AND D PATCHES
604001-05	FRAME AND LIDS, TYPE 1
606001-08	CONCRETE CURB TYPE B AND COMBINATION CONCRETE CURB AND GUTTER
701006-05	OFF-ROAD OPERATIONS, 2L, 2W, 15' TO 24" FROM PAVEMENT EDGE
701101-05	OFF-ROAD OPERATIONS, MULTILANE, 15' TO 24" FROM PAVEMENT EDGE
701301-04	LANE CLOSURE, 2L, 2W, SHORT TIME OPERATIONS
701311-03	LANE CLOSURE, 2L, 2W, MOVING OPERATIONS-DAY ONLY
701427-05	LANE CLOSURE, MULTILANE, INTERMITTENT OR MOVING OPER., FOR SPEEDS ≤ 40 MPH
701606-10	URBAN SINGLE LANE CLOSURE, MULTILANE, 2W WITH MOUNTABLE MEDIAN
701611-01	URBAN HALF ROAD CLOSURE, MULTILANE, 2W WITH MOUNTABLE MEDIAN
701701-10	URBAN LANE CLOSURE, MULTILANE INTERSECTION
701801-06	SIDEWALK, CORNER, OR CROSSWALK CLOSURE
701901-08	TRAFFIC CONTROL DEVICES
780001-05	TYPICAL PAVEMENT MARKINGS
781001-04	TYPICAL APPLICATIONS RAISED REFLECTIVE PAVEMENT MARKERS
886001-01	DETECTOR LOOP INSTALLATIONS
886006-01	TYPICAL LAYOUT FOR DETECTION LOOPS

## GENERAL NOTES

- BEFORE STARTING ANY EXCAVATION, THE CONTRACTOR SHALL CALL "J.U.L.I.E." AT (800) 892-0123 OR 811 FOR FIELD LOCATIONS OF BURIED UTILITY FACILITIES. 48 HOUR NOTICE IS REQUIRED.
- THE CONTRACTOR SHALL COORDINATE CONSTRUCTION ACTIVITIES WITH UTILITY COMPANIES, THE VILLAGE OF LAGRANGE PARK AND VILLAGE OF WESTCHESTER.
- THE CONTRACTOR WILL NOT BE ALLOWED TO SET UP A YARD OR FIELD OFFICE ON STATE PROPERTY WITHOUT WRITTEN PERMISSION FROM THE DEPARTMENT.
- THE CONTRACTOR SHALL CONTACT THE DISTRICT ONE TRAFFIC CONTROL SUPERVISOR KALPANA KANNAN-HOSADURGA AT KALPANA.KANNAN-HOSADURGA@ILLINOIS.GOV A MINIMUM OF 72 HOURS IN ADVANCE OF BEGINNING WORK AND INSTALLATION.
- THE ENGINEER SHALL CONTACT THE CENTRAL COOK TRAFFIC FIELD AREA ENGINEER EMAD AL HUSSEINI AT EMAD.ALHUSSEINI@ILLINOIS.GOV A MINIMUM OF TWO (2) WEEKS PRIOR TO THE PLACEMENT OF PERMANENT PLACEMENT MARKINGS.
- DO NOT SCALE PLANS FOR CONSTRUCTION DIMENSIONS.
- WHEN MILLED PAVEMENT IS OPEN TO TRAFFIC, THE MAXIMUM GRADE DIFFERENTIAL BETWEEN PASSES OF THE MILLING MACHINE SHALL NOT EXCEED 1½ INCHES. A MAXIMUM GRADE DIFFERENTIAL OF 3 INCHES MAY BE ALLOWED IF THE EDGE OF THE MILLING IS SLOPED AT A MINIMUM OF 1:3 (V:H), OR A NOTCHED LONGITUDINAL WEDGE IS USED.
- BUTT JOINTS SHALL BE INSTALLED AT THE ENDS OF ALL RESURFACING (WHERE RESURFACING MEETS EXISTING PAVEMENT) ACCORDING TO THE "BUTT JOINT AND HOT-MIX ASPHALT TAPER DETAILS" SHEET INCLUDED IN THE PLANS, UNLESS OTHERWISE SPECIFIED.
- UNLESS OTHER CONDITIONS WARRANT EXTENDED LANE CLOSURE AS DETERMINED AND APPROVED IN WRITING BY THE ENGINEER OR AS PROVIDED FOR IN THE CONTRACT SPECIFICATIONS, OVERNIGHT CLOSURES SHALL NOT BE ALLOWED FOR REHABILITATION PROJECTS INVOLVING DAYTIME MILLING, RESURFACING, AND CLASS D PATCHING OPERATIONS.
- THE CONTRACTOR SHALL EXERCISE CAUTION WHEN REMOVING OR EXCAVATING NEAR ALL EXISTING ITEMS WHICH WILL REMAIN. ANY DAMAGE DONE TO EXISTING ITEMS BY THE CONTRACTOR SHALL BE REPAIRED AT THE CONTRACTOR'S EXPENSE.
- THE CONTRACTOR SHALL BE REQUIRED TO PROVIDE ACCESS TO ABUTTING PROPERTIES AT ALL TIMES DURING THE CONSTRUCTION OF THIS PROJECT.
- THE LOCATION OF EXISTING DRAINAGE STRUCTURES, STORM SEWERS, WATER MAINS, SANITARY SEWERS, AND ANY OTHER PUBLIC OR PRIVATE UTILITIES AS SHOWN ON THE PLANS IS APPROXIMATE AND THEIR EXACT LOCATION IS TO BE DETERMINED IN THE FIELD BY THE CONTRACTOR.
- THE CONTRACTOR SHALL BE RESPONSIBLE FOR THE PROTECTION OF ALL UNDERGROUND AND SURFACE UTILITIES EVEN THOUGH THEY MIGHT NOT BE SHOWN IN THE PLANS. ANY UTILITY PROPERTY DAMAGED DURING CONSTRUCTION SHALL BE REPAIRED OR REPLACED TO THE SATISFACTION OF THE ENGINEER.
- ANY LOOSE MATERIAL DEPOSITED IN THE FLOW LINE OF DRAINAGE STRUCTURES WHICH OBSTRUCTS THE NATURAL FLOW OF WATER SHALL BE REMOVED AT THE CLOSE OF EACH WORKING DAY. PRIOR TO ACCEPTANCE OF THE IMPROVEMENT, ALL DRAINAGE STRUCTURES SHALL BE FREE OF DIRT AND DEBRIS. THIS WORK WILL NOT BE PAID FOR SEPARATELY, BUT SHALL BE CONSIDERED AS INCLUDED IN THE UNIT BID PRICES OF THE CONTRACT.
- THE CONTRACTOR SHALL MAINTAIN PEDESTRIAN ACCESS AT ALL TIMES DURING CONSTRUCTION.
- IT SHALL BE THE CONTRACTOR'S RESPONSIBILITY TO VERIFY ALL DIMENSIONS AND CONDITIONS EXISTING IN THE FIELD PRIOR TO CONSTRUCTION AND ORDERING OF MATERIALS.
- EXACT LOCATIONS OF PAVEMENT PATCHING AND CURB & GUTTER REMOVAL & REPLACEMENT WILL BE DETERMINED IN THE FIELD BY THE ENGINEER.
- ALL PAVEMENT MARKINGS SHALL BE PLACED THROUGHOUT THE IMPROVEMENT ACCORDING TO THE DISTRICT 1 TYPICAL PAVEMENT MARKING STANDARD DETAIL. ALL CROWWALKS SHALL BE HIGH VISIBILITY OPTION (TC-13 TYPICAL CROSSWALK MARKING, DETAIL B)
- ALL DAMAGE TO EXISTING PAVEMENT MARKINGS OR RAISED REFLECTIVE PAVEMENT MARKERS OUTSIDE THE REMOVAL LINE SHOWN ON THE PLANS SHALL BE REPLACED AT THE CONTRACTOR'S EXPENSE.
- PAVEMENT MARKING TAPE, TYPE III SHALL BE USED FOR TEMPORARY PAVEMENT MARKINGS ON ALL FINAL SURFACES.
- RELOCATION OF EXISTING PLANTER BOXES IS INCLUDED IN THE COST OF SIDEWALK REMOVAL.
- 2-FOOT TRANSITIONS SHALL BE USED TO MATCH PROPOSED CURB AND GUTTER ITEMS OR WORK TO EXISTING CURBS AND GUTTERS UNLESS OTHERWISE SHOWN. THE TRANSITIONS SHALL BE PAID FOR AT THE CONTRACT UNIT PRICE FOR THE PROPOSED ITEMS OF WORK.
- SAW CUTTING OF PAVEMENT, SIDEWALK, CURB & GUTTER, ETC. SHALL BE TO FULL DEPTH AND SHALL RESULT IN A CLEAN STRAIGHT EDGE ON THE PORTION REMAINING. ALL SAW CUTTING SHALL BE CONSIDERED INCLUDED IN THE COST OF THE ITEM REMOVED EXCEPT FR CLASS A PATCHES .
- LANDSCAPED AREAS AFFECTED BY SIDEWALK CONSTRUCTION AND EXISTING SIDEWALK TO BE REMOVED WITHOUT PROPOSED REPLACEMENT SHALL BE RESTORED WITH "SODDING, SALT TOLERANT" AND "TOPSOIL FURNISH AND PLACE, 4-INCH" AS DIRECTED BY THE ENGINEER.
- THE SIDEWALK ON ONLY ONE SIDE OF THE ROAD MAY BE CLOSED AT ANY TIME, WHILE THE SIDEWALK ON THE OPPOSITE SIDE OF THE ROAD SHALL REMAIN OPEN AND FULLY ACCESSIBLE. THE CONTRACTOR SHALL PLAN AND SCHEDULE ALL WORK ACCORDINGLY.
- PROPOSED SIDEWALK RAMPS SHALL CONFORM TO CURRENT ADA REQUIREMENTS AND APPLICABLE STATE HIGHWAY STANDARDS TO THE EXTENT POSSIBLE, TO BE DETERMINED BY THE ENGINEER.
- FRAMES AND GRATES ADJUSTMENT OF PRIVATE UTILITIES WITHIN THE LIMITS OF THE IMPROVEMENTS SHALL BE PERFORMED BY THEIR RESPECTIVE OWNERS AND ARE NOT PART OF THIS CONTRACT.
- DRAINAGE ADJUSTMENT OR RECONSTRUCTION LOCATIONS WILL BE DETERMINED IN THE FIELD BY THE ENGINEER.
- ANY DETECTOR LOOPS DAMAGED OUTSIDE OF THE RESURFACING LIMITS SHALL BE REPLACED BY THE CONTRACTOR AT NO EXPENSE TO THE DEPARTMENT.
- BEFORE BEGINNING ANY WORK THE CONTRACTOR SHALL RETAIN AND RECORD FOR FUTURE REFERENCE, ALL EXISTING PAVEMENT MARKING LINES (AND RAISED REFLECTIVE PAVEMENT MARKERS) SO THAT THESE LOCATIONS CAN BE RE-ESTABLISHED FOR STRIPING. EXACT LOCATIONS OF ALL PAVEMENT MARKINGS SHALL BE AS SHOWN ON THE PLANS OR AS DIRECTED BY THE ENGINEER.
- THE CONTRACTOR SHALL CONTACT THE IDOT ROADSIDE DEVELOPMENT UNIT AT (847) 705-4171 AT LEAST TWO (2) WEEKS PRIOR TO BEGINNING LANDSCAPE AND FORESTRY WORK FOR LAYOUT.
- ALL MILLED SURFACES SHALL BE AT A UNIFORM CROSS SLOPE PER LANE AND FREE OF RIDGES BETWEEN PASSES. ANY DEVIATION SHALL BE CORRECTED AT NO COST TO THE DEPARTMENT.
- ONLY CORNERS WITH CURB RAMP IMPROVEMENT SYMBOLS WILL BE RECONSTRUCTED UNDER THIS CONTRACT.

MODEL Path: G:\Engineering\Live\Projects\1003\_IDOT\_DWB\_HBR\10 - 62N43\CADD\CADD\_Sheets\CADD\161143-13-20-20-agencere.dgn  
FILE NAME: G:\Engineering\Live\Projects\1003\_IDOT\_DWB\_HBR\10 - 62N43\CADD\CADD\_Sheets\CADD\161143-13-20-20-agencere.dgn



USER NAME = jDavis	DESIGNED - MA	REVISED -
	DRAWN - MA	REVISED -
PLOT SCALE = 100,0000' / in.	CHECKED - JJD	REVISED -
PLOT DATE = 4/26/2022	DATE - 03/18/2021	REVISED -

### STATE OF ILLINOIS DEPARTMENT OF TRANSPORTATION

### INDEX OF SHEETS, STATE HIGHWAY STANDARDS, AND GENERAL NOTES US 12 /20 /45 OVERLAY AND ADA RAMP IMPROVEMENTS

SCALE: SHEET 1 OF 1 SHEETS STA. TO STA.

F.A.P. RTE.	SECTION	COUNTY	TOTAL SHEETS	SHEET NO.
330	2021-030-R5	COOK	35	2
CONTRACT NO. 62N43				
ILLINOIS FED. AID PROJECT 9P76(903)				

CODE NO.	ITEM	UNIT	TOTAL QUANTITY	CONSTRUCTION CODE		
				80% FED 20% STATE	80% FED 20% STATE	100% STATE
				ROADWAY	SAFETY	ROADWAY
				0005 URBAN	0021 URBAN	0005 URBAN
20101300	TREE PRUNING (1 TO 10 INCH DIAMETER)	EACH	2	2		
20101350	TREE PRUNING (OVER 10 INCH DIAMETER)	EACH	3	3		
20200100	EARTH EXCAVATION	CU YD	13	13		
21101615	TOPSOIL FURNISH AND PLACE, 4"	SQ YD	71	71		
21101630	TOPSOIL FURNISH AND PLACE, 8"	SQ YD	19	19		
25200110	SODDING, SALT TOLERANT	SQ YD	90	90		
25200200	SUPPLEMENTAL WATERING	UNIT	2	2		
40600290	BITUMINOUS MATERIALS (TACK COAT)	POUND	16785	16785		
40600370	LONGITUDINAL JOINT SEALANT	FOOT	22777	22777		
40600400	MIXTURE FOR CRACKS, JOINTS, AND FLANGEWAYS	TON	35	35		
40600982	HOT-MIX ASPHALT SURFACE REMOVAL - BUTT JOINT	SQ YD	221	221		
40605026	POLYMERIZED HOT-MIX ASPHALT SURFACE COURSE, STONE MATRIX ASPHALT, 9.5, MIX "F", N80	TON	3655	3655		
42001300	PROTECTIVE COAT	SQ YD	168	168		
42400200	PORTLAND CEMENT CONCRETE SIDEWALK 5 INCH	SQ FT	1149	1149		
42400800	DETECTABLE WARNINGS	SQ FT	83	83		

\* SPECIALTY ITEMS

CODE NO.	ITEM	UNIT	TOTAL QUANTITY	CONSTRUCTION CODE		
				80% FED 20% STATE	80% FED 20% STATE	100% STATE
				ROADWAY	SAFETY	ROADWAY
				0005 URBAN	0021 URBAN	0005 URBAN
44000156	HOT-MIX ASPHALT SURFACE REMOVAL, 1 3/4"	SQ YD	37300	37300		
44000200	DRIVEWAY PAVEMENT REMOVAL	SQ YD	19	19		
44000600	SIDEWALK REMOVAL	SQ FT	1098	1098		
44000500	COMBINATION CURB AND GUTTER REMOVAL	FOOT	21	21		
44201690	CLASS D PATCHES, TYPE I, 4 INCH	SQ YD	3	3		
44201692	CLASS D PATCHES, TYPE II, 4 INCH	SQ YD	14	14		
44201789	CLASS D PATCHES, TYPE II, 12 INCH	SQ YD	128	128		
44201794	CLASS D PATCHES, TYPE III, 12 INCH	SQ YD	306	306		
44201796	CLASS D PATCHES, TYPE IV, 12 INCH	SQ YD	174	174		
44213200	SAW CUTS	FOOT	21	21		
60250200	CATCH BASINS TO BE ADJUSTED	EACH	1	1		
60252800	CATCH BASINS TO BE RECONSTRUCTED	EACH	1	1		
60255500	MANHOLES TO BE ADJUSTED	EACH	1	1		
60300105	FRAMES AND GRATES TO BE ADJUSTED	EACH	2	2		
60605000	COMBINATION CONCRETE CURB AND GUTTER, TYPE B-6.24	FOOT	21	21		
63100167	TRAFFIC BARRIER TERMINAL, TYPE 1 (SPECIAL) TANGENT	EACH	2	2		
63100169	TRAFFIC BARRIER TERMINAL, TYPE 1 (SPECIAL) FLARED	EACH	1	1		
* 66900200	NON-SPECIAL WASTE DISPOSAL	CU YD	13	13		

\* SPECIALTY ITEMS

MODEL: S00\_1  
FILE: MAINT\_C:\Engineering\Live\Projects\1003\_IDOT\_DIB\_HDR\WD 1 - 62N43\CADD\CADD\_Sheets\CIVIL\162143-INT-S00.dgn



USER NAME = malkufahy	DESIGNED - MA	REVISED -
	DRAWN - MA	REVISED -
PLOT SCALE = 100.0000' / in.	CHECKED - JJD	REVISED -
PLOT DATE = 3/23/2022	DATE - 03/18/2021	REVISED -

**STATE OF ILLINOIS  
DEPARTMENT OF TRANSPORTATION**

**SUMMARY OF QUANTITIES  
US 12 /20 /45 OVERLAY AND ADA RAMP IMPROVEMENTS**

SCALE: SHEET 1 OF 3 SHEETS STA. TO STA.

F.A.P. RTE.	SECTION	COUNTY	TOTAL SHEETS	SHEET NO.
330	2021-030-R5	COOK	35	3
CONTRACT NO. 62N43			ILLINOIS FED. AID PROJECT 9P76(903)	

MODEL: S00\_2  
FILE NAME: C:\Engineering\1\live\Projects\1003\_IDOT\_DUB\_HBR\WID\_1 - 62N43\CADD\CADD\_Sheets\CIMD\1631N43-INT-S00.dgn

CODE NO.	ITEM	UNIT	TOTAL QUANTITY	CONSTRUCTION CODE		
				80% FED 20% STATE ROADWAY	80% FED 20% STATE SAFETY	100% STATE ROADWAY
				0005	0021	0005
				URBAN	URBAN	URBAN
*66900530	SOIL DISPOSAL ANALYSIS	EACH	2	2		
*66901001	REGULATED SUBSTANCES PRE-CONSTRUCTION PLAN	L SUM	1	1		
*66901003	REGULATED SUBSTANCES FINAL CONSTRUCTION REPORT	L SUM	1	1		
*66901006	REGULATED SUBSTANCES MONITORING	CAL DA	3	3		
67100100	MOBILIZATION	L SUM	1	1		
70102625	TRAFFIC CONTROL AND PROTECTION, STANDARD 701606	L SUM	1	1		
70102634	TRAFFIC CONTROL AND PROTECTION, STANDARD 701611	L SUM	1	1		
70102635	TRAFFIC CONTROL AND PROTECTION, STANDARD 701701	L SUM	1	1		
70102640	TRAFFIC CONTROL AND PROTECTION, STANDARD 701801	L SUM	1	1		
70300100	SHORT TERM PAVEMENT MARKING	FOOT	8424	8424		
70300150	SHORT TERM PAVEMENT MARKING REMOVAL	SQ FT	2808	2808		
70300211	TEMPORARY PAVEMENT MARKING LETTERS AND SYMBOLS - PAINT	SQ FT	364	364		
70300221	TEMPORARY PAVEMENT MARKING - LINE 4"- PAINT	FOOT	17454	17454		
70300241	TEMPORARY PAVEMENT MARKING - LINE 6"- PAINT	FOOT	2340	2340		

\* SPECIALTY ITEMS

CODE NO.	ITEM	UNIT	TOTAL QUANTITY	CONSTRUCTION CODE		
				80% FED 20% STATE ROADWAY	80% FED 20% STATE SAFETY	100% STATE ROADWAY
				0005	0021	0005
				URBAN	URBAN	URBAN
70300251	TEMPORARY PAVEMENT MARKING - LINE 8"- PAINT	FOOT	493	493		
70300261	TEMPORARY PAVEMENT MARKING - LINE 12"- PAINT	FOOT	258	258		
70300281	TEMPORARY PAVEMENT MARKING - LINE 24"- PAINT	FOOT	327	327		
*72400600	RELOCATE SIGN PANEL ASSEMBLY - TYPE B	EACH	1	1		
*72800100	TELESCOPING STEEL SIGN SUPPORT	FOOT	9	9		
*78000100	THERMOPLASTIC PAVEMENT MARKING - LETTERS AND SYMBOLS	SQ FT	364	364		
*78000200	THERMOPLASTIC PAVEMENT MARKING - LINE 4"	FOOT	17454	17454		
*78000400	THERMOPLASTIC PAVEMENT MARKING - LINE 6"	FOOT	2340	2340		
*78000500	THERMOPLASTIC PAVEMENT MARKING - LINE 8"	FOOT	493	493		
*78000600	THERMOPLASTIC PAVEMENT MARKING - LINE 12"	FOOT	258	258		
*78000650	THERMOPLASTIC PAVEMENT MARKING - LINE 24"	FOOT	327	327		
*78004635	PREFORMED PLASTIC PAVEMENT MARKING, TYPE D - LINE 7"	FOOT	110	110		
*78009004	MODIFIED URETHANE PAVEMENT MARKING - LINE 4"	FOOT	816	816		
*78009006	MODIFIED URETHANE PAVEMENT MARKING - LINE 6"	FOOT	80	80		

\* SPECIALTY ITEMS



USER NAME = jldavis	DESIGNED - MA	REVISED -
	DRAWN - MA	REVISED -
PLOT SCALE = 100,0000' / in.	CHECKED - JJD	REVISED -
PLOT DATE = 3/23/2022	DATE - 03/18/2021	REVISED -

**STATE OF ILLINOIS  
DEPARTMENT OF TRANSPORTATION**

SUMMARY OF QUANTITIES	
US 12 /20 /45 OVERLAY AND ADA RAMP IMPROVEMENTS	
SCALE:	SHEET 2 OF 3 SHEETS STA. TO STA.

F.A.P. RTE. 330	SECTION 2021-030-R5	COUNTY COOK	TOTAL SHEETS 35	SHEET NO. 4
CONTRACT NO. 62N43			ILLINOIS FED. AID PROJECT 9P76(903)	

MODEL: S00\_3  
 FILE: MAINT\_G:\Engineering\Live\Projects\1003\_IDOT\_DUA\_HDR\WD 1 - 62M43\CADD\CADD\_Sheets\CIVIL\1621M43-ent-S00.dgn

CODE NO.	ITEM	UNIT	TOTAL QUANTITY	CONSTRUCTION CODE		
				80% FED 20% STATE	80% FED 20% STATE	100% STATE
				ROADWAY	SAFETY	ROADWAY
				0005 URBAN	0021 URBAN	0005 URBAN
* 78009012	MODIFIED URETHANE PAVEMENT MARKING - LINE 12"	FOOT	47	47		
* 78011040	GROOVING FOR RECESSED PAVEMENT MARKING 8"	FOOT	110	110		
* 78100100	RAISED REFLECTIVE PAVEMENT MARKER	EACH	672	672		
78300200	RAISED REFLECTIVE PAVEMENT MARKER REMOVAL	EACH	582	582		
78300202	PAVEMENT MARKING REMOVAL - WATER BLASTING	SQ FT	8908	8908		
* 81028200	UNDERGROUND CONDUIT, GALVANIZED STEEL, 2" DIA.	FOOT	50	50		
* 85000200	MAINTENANCE OF EXISTING TRAFFIC SIGNAL INSTALLATION	EACH	1	1		
* 87301215	ELECTRIC CABLE IN CONDUIT, SIGNAL NO. 14 2C	FOOT	1540	1540		
* 87301900	ELECTRIC CABLE IN CONDUIT, EQUIPMENT GROUNDING CONDUCTOR, NO. 6 1C	FOOT	83	83		
* 87900200	DRILL EXISTING HANDHOLE	EACH	5	5		
* 88600600	DETECTOR LOOP REPLACEMENT	FOOT	593	593		
* 89502200	MODIFY EXISTING CONTROLLER	EACH	1	1		
* 89502300	REMOVE ELECTRIC CABLE FROM CONDUIT	FOOT	578	578		
* 89502375	REMOVE EXISTING TRAFFIC SIGNAL EQUIPMENT	EACH	1	1		

\* SPECIALTY ITEMS

CODE NO.	ITEM	UNIT	TOTAL QUANTITY	CONSTRUCTION CODE		
				80% FED 20% STATE	80% FED 20% STATE	100% STATE
				ROADWAY	SAFETY	ROADWAY
				0005 URBAN	0021 URBAN	0005 URBAN
X0320050	CONSTRUCTION LAYOUT (SPECIAL)	L SUM	1	1		
X0326806	WASHOUT BASIN	L SUM	1	1		
X0326898	CENTER LINE - RUMBLE STRIP - 16"	FOOT	1188	1188		
* X1400378	PEDESTRIAN SIGNAL POST, 5 FT.	EACH	5	5		
X2100002	PRUNING FOR SAFETY AND EQUIPMENT CLEARANCE	UNIT	5.9	5.9		
X4400501	COMBINATION CURB AND GUTTER REMOVAL AND REPLACEMENT LESS THAN OR EQUAL TO 10 FEET	FOOT	30	30		
X5537800	STORM SEWERS TO BE CLEANED 12"	FOOT	340		340	
X6700407	ENGINEER'S FIELD OFFICE, TYPE A (D1)	CAL MO	12	12		
* X8760200	ACCESSIBLE PEDESTRIAN SIGNALS	EACH	8	8		
* X8780012	CONCRETE FOUNDATION, TYPE A 12-INCH DIAMETER	FOOT	20	20		
Z0004562	COMBINATION CURB AND GUTTER REMOVAL AND REPLACEMENT	FOOT	431	431		
Z0018100	DRAINAGE STRUCTURE ADJUSTMENT (SPECIAL)	EACH	15	15		
Z0018500	DRAINAGE STRUCTURES TO BE CLEANED	EACH	17		17	
Z0030850	TEMPORARY INFORMATION SIGNING	SQ FT	257	257		
* Z0033044	RE-OPTIMIZE TRAFFIC SIGNAL SYSTEM LEVEL 1	EACH	1	1		
Ø Z0076600	TRAINEES	HOURS	500	500		
Ø Z0076604	TRAINEES - TRAINING PROGRAM GRADUATE	HOURS	500	500		

\* SPECIALTY ITEMS



USER NAME = jdavis	DESIGNED - MA	REVISED -
PLOT SCALE = 100.0000' / in.	DRAWN - MA	REVISED -
PLOT DATE = 3/23/2022	CHECKED - JJD	REVISED -
	DATE - 03/18/2021	REVISED -

**STATE OF ILLINOIS  
 DEPARTMENT OF TRANSPORTATION**

<b>SUMMARY OF QUANTITIES</b>	
<b>US 12 /20 /45 OVERLAY AND ADA RAMP IMPROVEMENTS</b>	
SCALE:	SHEET 3 OF 3 SHEETS STA. TO STA.

F.A.P. RTE. 330	SECTION 2021-030-R5	COUNTY COOK	TOTAL SHEETS 35	SHEET NO. 5
CONTRACT NO. 62N43			ILLINOIS FED. AID PROJECT 9P76(903)	

Ø 0042

INTERSECTION	20200100 EARTH EXCAVATION CU YD	21101615 TOPSOIL F&P 4 SQ YD	25200110 SODDING SALT TOLERANT SQ YD	25200200 SUPPLE WATERING UNIT	42001300 PROTECTIVE COAT SQ YD	42400200 PC CONC SIDEWALK 5" SQ FT	42400800 DETECTABLE WARNINGS SQ FT	44000600 SIDEWALK REM SQ FT	44201690 CL D PATCH T1 4 SQ YD	44201692 CL D PATCH T2 4 SQ YD	60250200 CATCH BASINS ADJUST EACH	60255500 MANHOLES TO BE ADJUSTED EACH	72400600 RELOC SIN PAN ASSY TB EACH	72800100 TELES STL SIN SUPPORT FOOT	Z0004562 COMB C&G REMOV REPL FOOT
LAGRANGE RD AND 30TH ST	5	36	36	0.5	56	444	20	429	2.5	0.0	1	1	0	0	23
LAGRANGE RD AND CERMAK RD	8	35	35	0.5	112	705	63	669	0.0	13.6	0	0	1	9	123
<b>TOTAL</b>	<b>13</b>	<b>71</b>	<b>71</b>	<b>2</b>	<b>168</b>	<b>1149</b>	<b>83</b>	<b>1098</b>	<b>3</b>	<b>14</b>	<b>1</b>	<b>1</b>	<b>1</b>	<b>9</b>	<b>146</b>

MODEL Schedule 1  
 FILE NAME: C:\Engineering\Live\Projects\1003\_IDOT\_DUB\_HBR\WID\_1 - 62M43\CADD\CADD\_Sheets\CURB\ADA\_Schedule.dgn



USER NAME = ma\kufahy	DESIGNED - MA	REVISED -
	DRAWN - MA	REVISED -
PLOT SCALE = 100,0000' / in.	CHECKED - JJD	REVISED -
PLOT DATE = 3/23/2022	DATE - 03/18/2021	REVISED -

**STATE OF ILLINOIS**  
**DEPARTMENT OF TRANSPORTATION**

<b>ADA CURB RAMP SCHEDULE OF QUANTITIES</b> <b>US 12 /20 /45 OVERLAY AND ADA RAMP IMPROVEMENTS</b>			
SCALE:	SHEET	OF	SHEETS
	STA.	TO	STA.

F.A.P. RTE.	SECTION	COUNTY	TOTAL SHEETS	SHEET NO.
330	2021-030-R5	COOK	35	6
			CONTRACT NO. 62N43	
			ILLINOIS FED. AID PROJECT 9P76(903)	

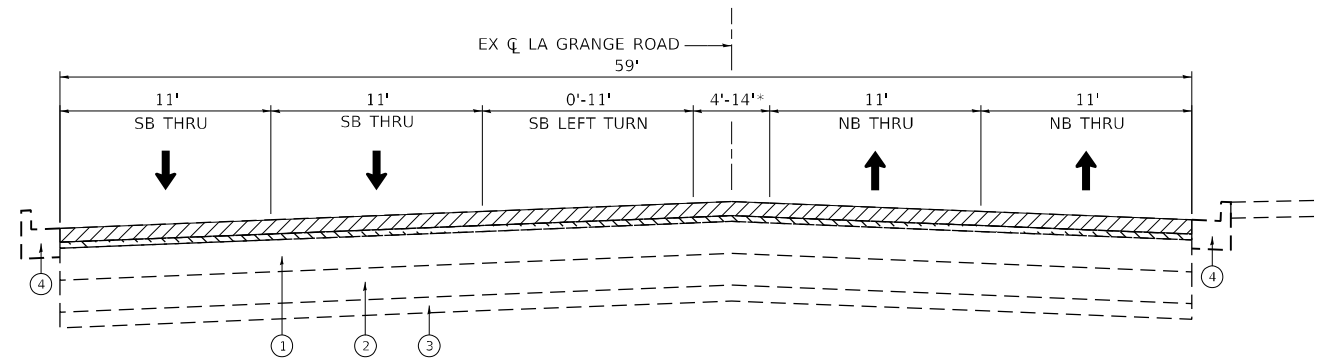

**EXISTING TYPICAL SECTION**

STA 16+37 TO STA 19+29

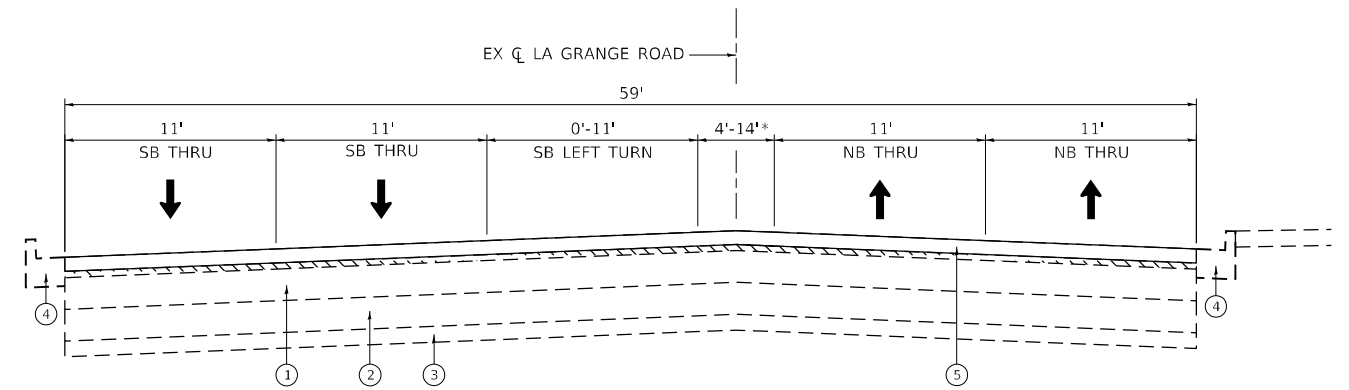

**PROPOSED TYPICAL SECTION**

STA 16+37 TO STA 19+29

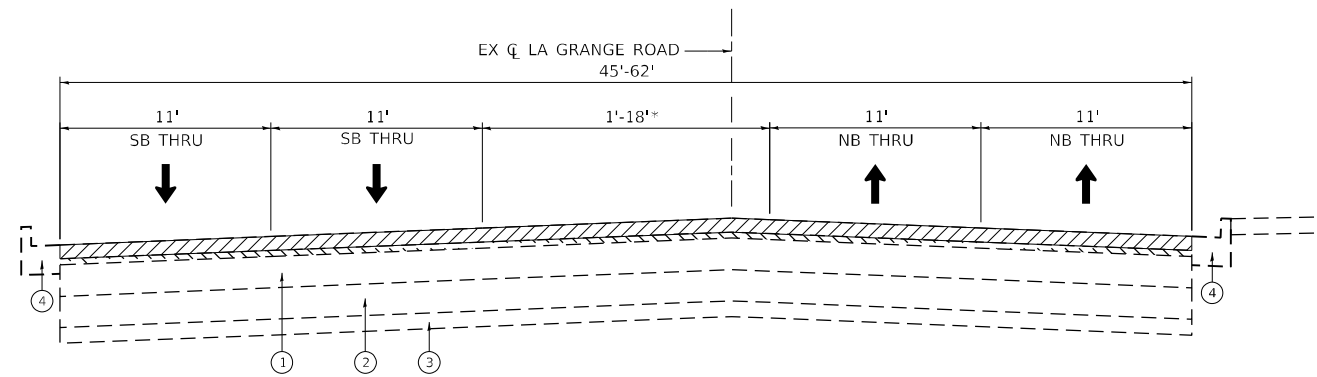

**EXISTING TYPICAL SECTION**

STA 19+29 TO STA 65+41

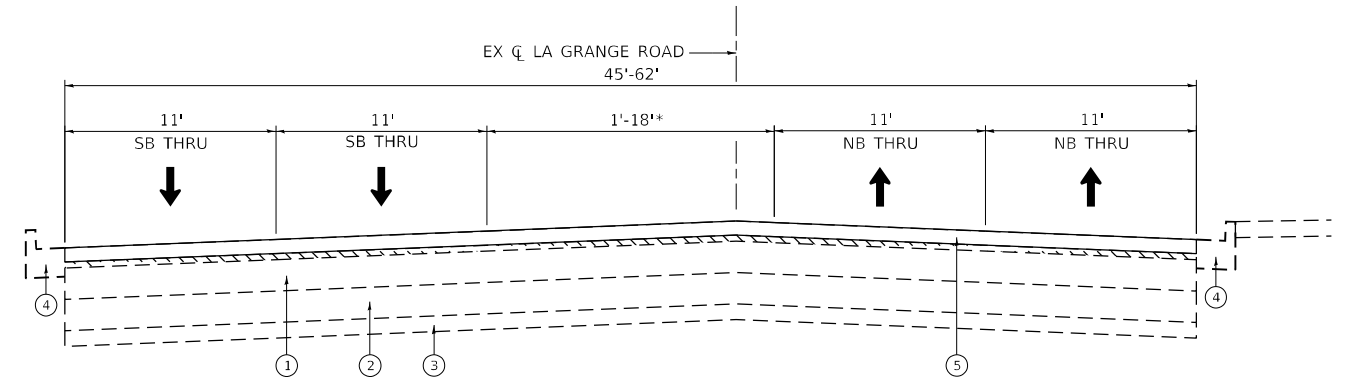

**PROPOSED TYPICAL SECTION**

STA 19+29 TO STA 65+41

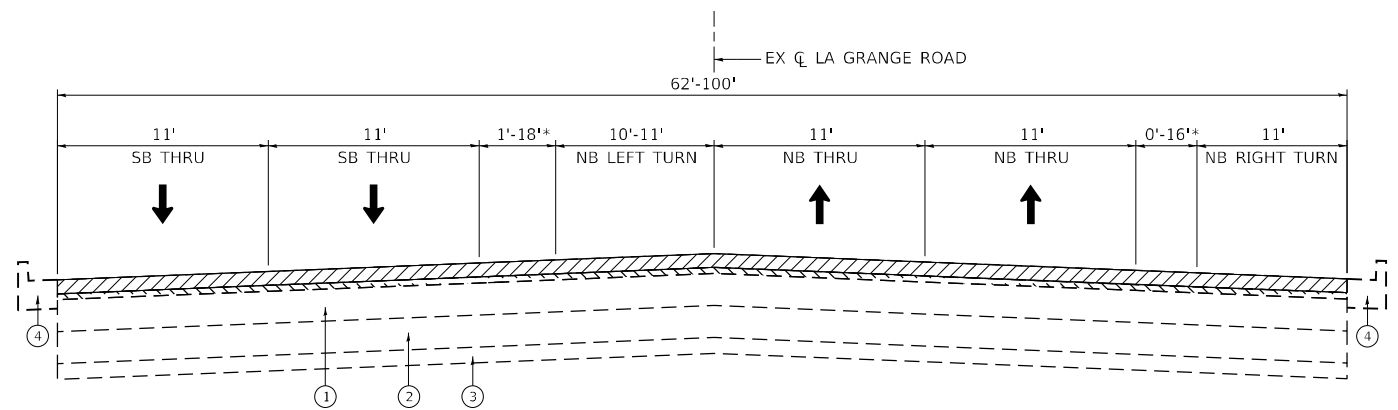

**EXISTING TYPICAL SECTION**

STA 65+41 TO STA 71+24  
(ROADWAY GORES NOT SHOWN IN PAVEMENT MARKING DIMENSIONS)

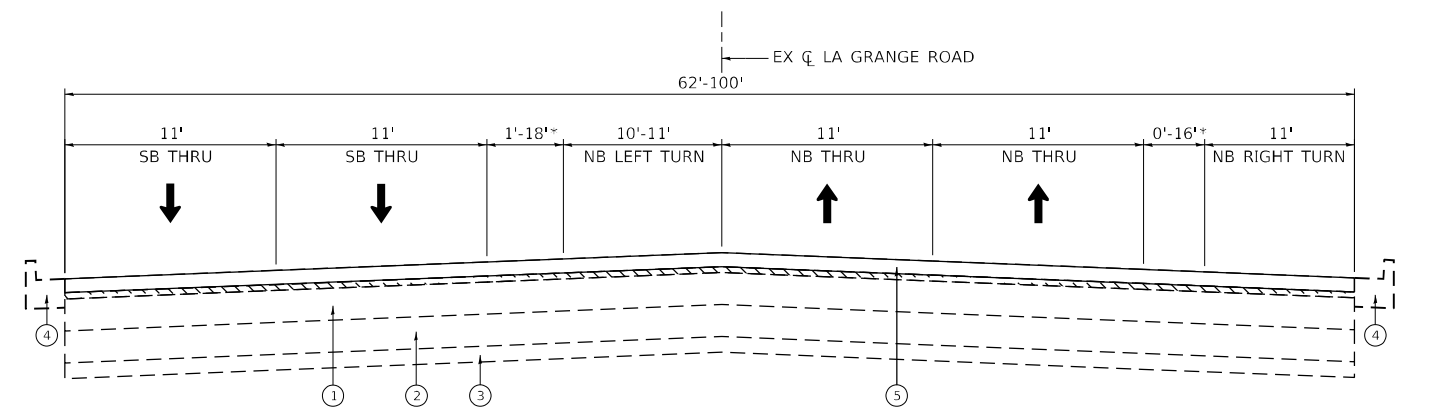

**PROPOSED TYPICAL SECTION**

STA 65+41 TO STA 71+24  
(ROADWAY GORES NOT SHOWN IN PAVEMENT MARKING DIMENSIONS)

**LEGEND**

- HOT-MIX ASPHALT SURFACE REMOVAL, 1 3/4"
- EXISTING POLYMERIZED LEVELING BINDER (MM), IL-4.75, N50, 3/4"
- EXISTING HMA (VARYING, 3"-10")
- EXISTING PCC PAVEMENT (VARYING 7"-10")
- EXISTING SUBBASE GRANULAR MATERIAL, 6"
- EXISTING CONCRETE CURB AND GUTTER
- PROPOSED POLYMERIZED HOT-MIX ASPHALT SURFACE COURSE, STONE MATRIX ASPHALT, 9.5, MIX "F", N80, 1 3/4"
- PAINTED MEDIAN OR GORE

MODEL: D:\p\h\...  
 FILE: NAME: G:\Engineering\Live\Projects\1003\_IDOT\_DUB\_HBR\WID - 62N43\CADD\CADD\_Sheets\CURB\62N43-2022-03-18.dgn



USER NAME = malku/ahy	DESIGNED - MA	REVISED -
DRAWN - MA	REVISED -	
PLOT SCALE = 10,0000 * / in.	CHECKED - JJD	REVISED -
PLOT DATE = 3/23/2022	DATE - 03/18/2021	REVISED -

**STATE OF ILLINOIS  
DEPARTMENT OF TRANSPORTATION**

<b>TYPICAL SECTIONS AND DETAILS</b>		
<b>US 12 /20 /45 OVERLAY AND ADA RAMP IMPROVEMENTS</b>		
SCALE: NONE	SHEET 1 OF 2 SHEETS	STA. TO STA.

F.A.P. RTE. 330	SECTION 2021-030-R5	COUNTY COOK	TOTAL SHEETS 35	SHEET NO. 7
CONTRACT NO. 62N43				
ILLINOIS FED. AID PROJECT 9P76(903)				

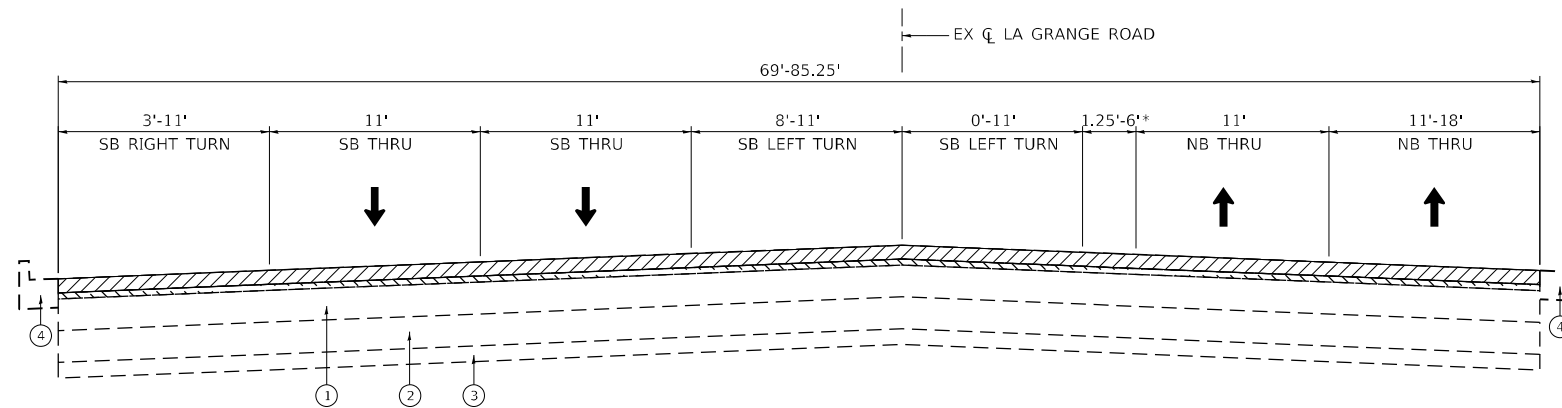

**EXISTING TYPICAL SECTION**

STA 71+24 TO STA 74+95 SB & STA 75+15 NB

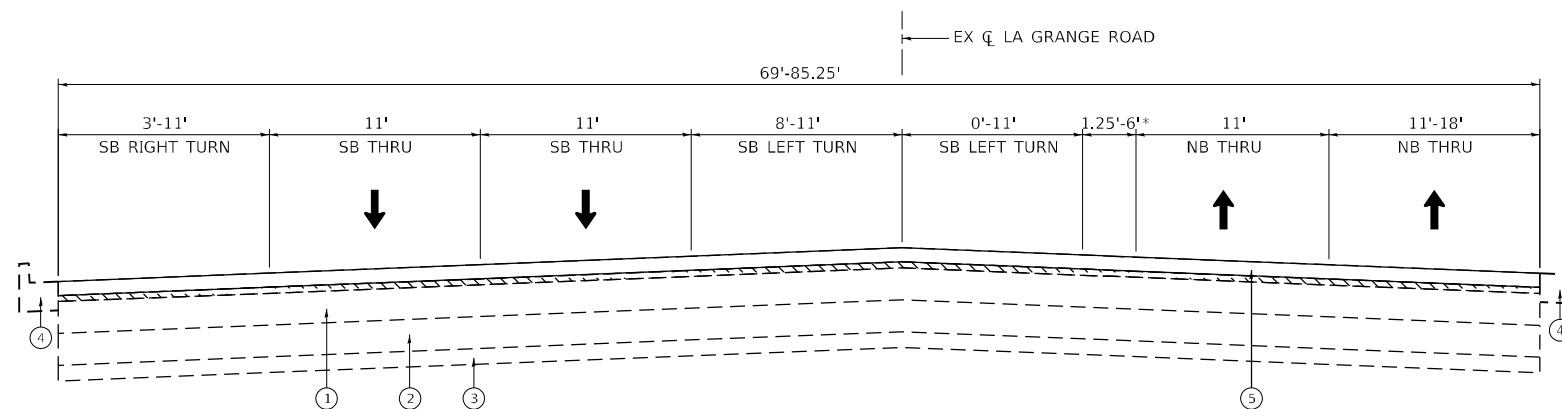

**PROPOSED TYPICAL SECTION**

STA 71+24 TO STA 74+95 SB & STA 75+15 NB

**LEGEND**

- HOT-MIX ASPHALT SURFACE REMOVAL, 1 3/4"
- EXISTING POLYMERIZED LEVELING BINDER (MM), IL-4.75, N50, 3/4"
- ① EXISTING HMA (VARYING, 3"-10")
- ② EXISTING PCC PAVEMENT (VARYING 7"-10")
- ③ EXISTING SUBBASE GRANULAR MATERIAL, 6"
- ④ EXISTING CONCRETE CURB AND GUTTER
- ⑤ PROPOSED POLYMERIZED HOT-MIX ASPHALT SURFACE COURSE, STONE MATRIX ASPHALT, 9.5, MIX "F", N80, 1 3/4"
- \* PAINTED MEDIAN OR GORE

**HMA MIXTURE REQUIREMENTS CHART**

OPERATION	MIXTURE TYPE	AIR VOIDS (%) @ Ndes	QUALITY MANAGEMENT PROGRAM (QMP)
PAVEMENT RESURFACING	POLYMERIZED HOT-MIX ASPHALT SURFACE COURSE, STONE MATRIX ASPHALT, MIX "F", 9.5, N80, 1 3/4"	3.5% @ 80 Gyr.	QCP
CLASS D PATCHES	HOT-MIX ASPHALT BINDER, IL-19.0	4% @ 70 Gyr.	QC/QA
QUALITY MANAGEMENT PROGRAM (QMP) DESIGNATION: QUALITY CONTROL/QUALITY ASSURANCE (QC/QA) QUALITY CONTROL FOR PERFORMANCE (QCP)			

**NOTES**

1. THE UNIT WEIGHT USED TO CALCULATE ALL HOT-MIX ASPHALT SURFACE MIXTURES IS 112 LB/SY/IN.
2. THE "AC TYPE" FOR POLYMERIZED HMA MIXES SHALL BE "SBS/SBR 76-22", AND FOR NON-POLYMERIZED HMA THE "AC TYPE" SHALL BE "PG 64-22" UNLESS MODIFIED BY RECLAIMED MATERIALS SPECIFICATION.
3. LONGITUDINAL JOINT SEALANT SHALL BE PLACED OVER MILLED SURFACE.
4. CONTRACTOR SHALL MILL BEFORE PATCHING.
5. RESURFACING OMISSION BETWEEN STATIONS 67+45 AND 69+49 ON BRIDGE.

MODEL: D:\p\h\l\... FILE NAME: G:\Engineering\Live\Projects\1003\_IDOT\_DUB\_HBR\VID - 62N43\CADD\CADD\_Sheets\CURB\162N43-INT-CYRICAL2.dgn



USER NAME = jdavis	DESIGNED - MA	REVISED -
	DRAWN - MA	REVISED -
PLOT SCALE = 10,0000 * / in.	CHECKED - JJD	REVISED -
PLOT DATE = 4/26/2022	DATE - 03/18/2021	REVISED -

**STATE OF ILLINOIS  
DEPARTMENT OF TRANSPORTATION**

**TYPICAL SECTIONS AND DETAILS  
US 12 /20 /45 OVERLAY AND ADA RAMP IMPROVEMENTS**

SCALE: NONE SHEET 2 OF 2 SHEETS STA. TO STA.

F.A.P. RTE. 330	SECTION 2021-030-R5	COUNTY COOK	TOTAL SHEETS 35	SHEET NO. 8
CONTRACT NO. 62N43				
ILLINOIS FED. AID PROJECT 9P76(903)				



**SIDEWALK LEGEND**

- CURB RAMP IMPROVEMENT, SEE ADA CURB RAMP DETAILS PLAN
- CURB RAMP IMPROVEMENT, SEE PD-04A

**NOTES:**

1. INSTALL PAVEMENT MARKINGS IN ACCORDANCE WITH DISTRICT ONE STANDARD DETAIL TC-13 - TYPICAL PAVEMENT MARKINGS. CROSSWALKS ARE 6' WIDE UNLESS OTHERWISE NOTED. STOP LINE SETBACK FROM ALL CROSSWALKS IS 4'.
2. INSTALL RAISED REFLECTIVE PAVEMENT MARKERS IN ACCORDANCE WITH DISTRICT ONE STANDARD DETAIL TC-11 - RAISED REFLECTIVE PAVEMENT MARKERS (SNOW-PLOW RESISTANT). OMIT RAISED REFLECTIVE MARKERS ON BRIDGE.
3. PAVEMENT MARKINGS FROM STA. 16+07 TO STA. 16+37 WILL BE REMOVED BY WATER BLASTING AND REPLACED IN-KIND.

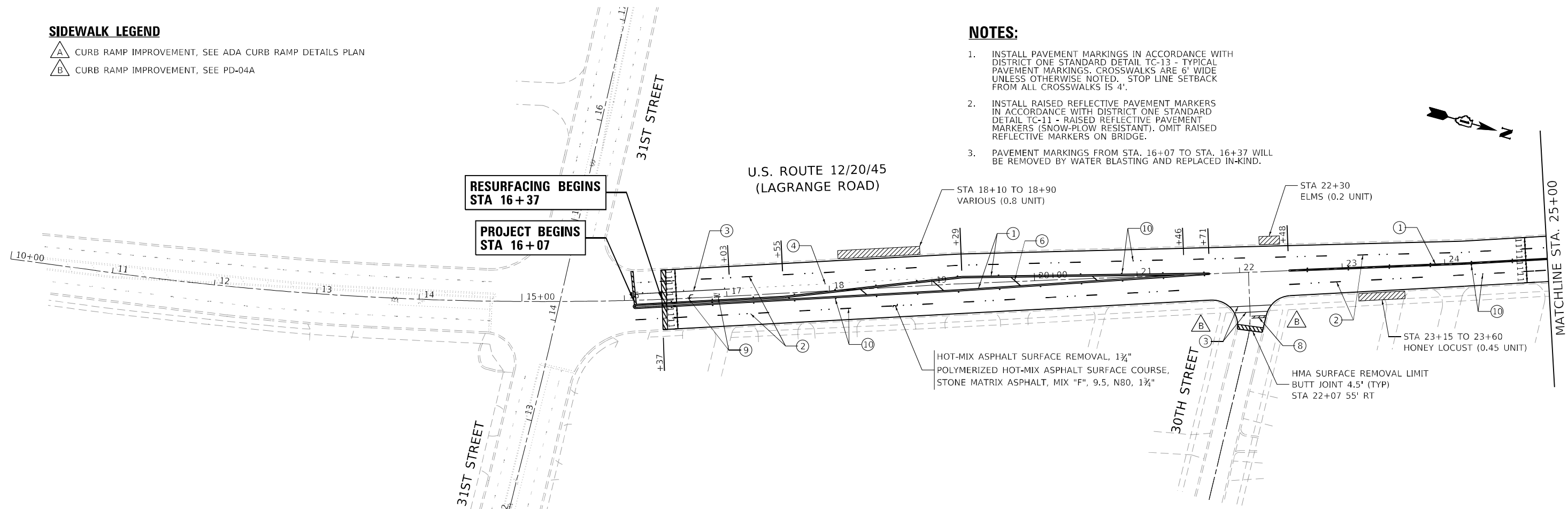

**PAVEMENT MARKING LEGEND**

- |  |  |   |
|--|--|---|
| <ul style="list-style-type: none"> <li>① THERMOPLASTIC PAVEMENT MARKING - LINE 4" (YELLOW SOLID, DOUBLE CENTERLINE)</li> <li>② THERMOPLASTIC PAVEMENT MARKING - LINE 4" (WHITE 10'-30' SKIP LINE)</li> <li>③ THERMOPLASTIC PAVEMENT MARKING - LINE 6" (WHITE SOLID)</li> <li>④ THERMOPLASTIC PAVEMENT MARKING - LINE 6" (WHITE 2'-6" SKIP LINE)</li> <li>⑤ THERMOPLASTIC PAVEMENT MARKING - LINE 8" (WHITE SOLID)</li> <li>⑥ THERMOPLASTIC PAVEMENT MARKING - LINE 12" (YELLOW DIAGONALS @ 45°, 75' SPACING UNLESS NOTED, 5 MIN.)</li> </ul> | <ul style="list-style-type: none"> <li>⑦ THERMOPLASTIC PAVEMENT MARKING - LINE 12" (WHITE CHEVRON @ 45°, CONTINENTAL-STYLE CROSSWALK, OR DIAGONALS-STYLE CROSSWALK)</li> <li>⑧ THERMOPLASTIC PAVEMENT MARKING - LINE 24" (WHITE SOLID)</li> <li>⑨ THERMOPLASTIC PAVEMENT MARKING - LETTERS &amp; SYMBOLS (WHITE)</li> <li>⑩ RAISED REFLECTIVE PAVEMENT MARKERS</li> <li>⑪ PREFORMED PLASTIC PAVEMENT MARKING - LINE 7" (4" WHITE OVER 7" BLACK, 10'-30' SKIP LINE) GROOVING FOR RECESSED PAVEMENT MARKING, 8"</li> </ul> | <ul style="list-style-type: none"> <li>⑫ MODIFIED URETHANE PAVEMENT MARKING - LINE 6" (WHITE 2'-6" SKIP LINE)</li> <li>⑬ MODIFIED URETHANE PAVEMENT MARKING - LINE 4" (YELLOW SOLID, DOUBLE CENTERLINE)</li> <li>⑭ MODIFIED URETHANE PAVEMENT MARKING - LINE 12" (YELLOW DIAGONALS @ 45°, 75' SPACING UNLESS NOTED, 5 MIN.)</li> <li>⑮ TRAFFIC BARRIER TERMINAL, TYPE 1 (SPECIAL) TANGENT</li> <li>⑯ TRAFFIC BARRIER TERMINAL, TYPE 1 (SPECIAL) FLARED</li> </ul> |
|--|--|---|

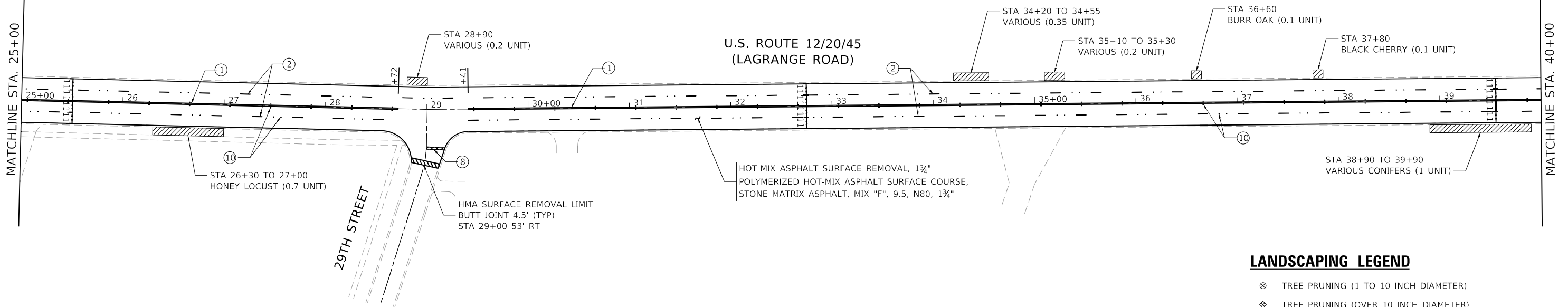

**LANDSCAPING LEGEND**

- TREE PRUNING (1 TO 10 INCH DIAMETER)
- TREE PRUNING (OVER 10 INCH DIAMETER)
- PRUNING FOR SAFETY AND EQUIPMENT CLEARANCE

MODEL Path: G:\Engineering\LiveProjects\21003\_IDOT\_DUB\_HBRW\1 - 62N43\CADD\CADD\_Sheets\CHRD\62N43-21003-21003-1.dwg





USER NAME = jdavis	DESIGNED - MA	REVISED -
	DRAWN - MA	REVISED -
PLOT SCALE = 100,0000' / in.	CHECKED - JJD	REVISED -
PLOT DATE = 4/26/2022	DATE - 03/18/2021	REVISED -

**STATE OF ILLINOIS  
DEPARTMENT OF TRANSPORTATION**

<b>RESURFACING AND PAVEMENT MARKING PLAN</b>	
<b>US 12 / 20 / 45 OVERLAY AND ADA RAMP IMPROVEMENTS</b>	
SCALE: 1"=50'	SHEET 1 OF 3 SHEETS
STA. 10+00	TO STA. 40+00

F.A.P. RTE. 330	SECTION 2021-030-R5	COUNTY COOK	TOTAL SHEETS 35	SHEET NO. 9
CONTRACT NO. 62N43				
ILLINOIS FED. AID PROJECT 9P76(903)				

**SIDEWALK LEGEND**



-  CURB RAMP IMPROVEMENT, SEE ADA CURB RAMP DETAILS PLAN
-  CURB RAMP IMPROVEMENT, SEE PD-04A

**NOTES:**

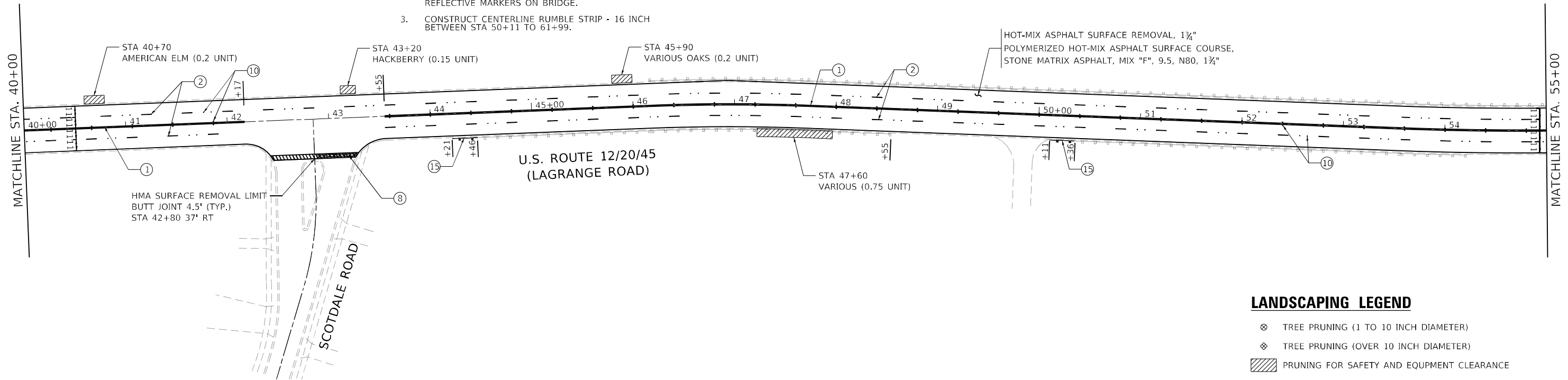
1. INSTALL PAVEMENT MARKINGS IN ACCORDANCE WITH DISTRICT ONE STANDARD DETAIL TC-13 - TYPICAL PAVEMENT MARKINGS. CROSSWALKS ARE 6' WIDE UNLESS OTHERWISE NOTED. STOP LINE SETBACK FROM ALL CROSSWALKS IS 4'.
2. INSTALL RAISED REFLECTIVE PAVEMENT MARKERS IN ACCORDANCE WITH DISTRICT ONE STANDARD DETAIL TC-11 - RAISED REFLECTIVE PAVEMENT MARKERS (SNOW-PLOW RESISTANT). OMIT RAISED REFLECTIVE MARKERS ON BRIDGE.
3. CONSTRUCT CENTERLINE RUMBLE STRIP - 16 INCH BETWEEN STA 50+11 TO 61+99.



**LANDSCAPING LEGEND**

-  TREE PRUNING (1 TO 10 INCH DIAMETER)
-  TREE PRUNING (OVER 10 INCH DIAMETER)
-  PRUNING FOR SAFETY AND EQUIPMENT CLEARANCE

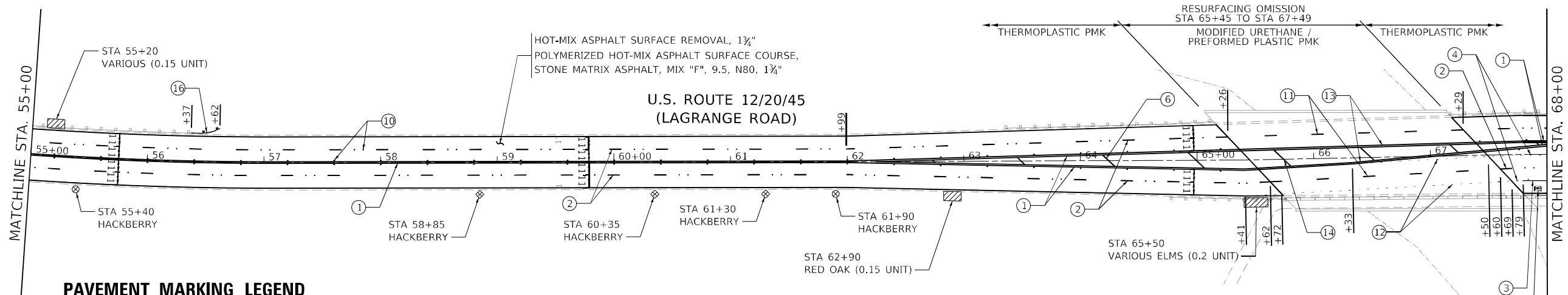

**PAVEMENT MARKING LEGEND**

- ① THERMOPLASTIC PAVEMENT MARKING - LINE 4" (YELLOW SOLID, DOUBLE CENTERLINE)
- ② THERMOPLASTIC PAVEMENT MARKING - LINE 4" (WHITE 10'-30" SKIP LINE)
- ③ THERMOPLASTIC PAVEMENT MARKING - LINE 6" (WHITE SOLID)
- ④ THERMOPLASTIC PAVEMENT MARKING - LINE 6" (WHITE 2'-6" SKIP LINE)
- ⑤ THERMOPLASTIC PAVEMENT MARKING - LINE 8" (WHITE SOLID)
- ⑥ THERMOPLASTIC PAVEMENT MARKING - LINE 12" (YELLOW DIAGONALS @ 45°, 75' SPACING UNLESS NOTED, 5 MIN.)
- ⑦ THERMOPLASTIC PAVEMENT MARKING - LINE 12" (WHITE CHEVRON @ 45°, CONTINENTAL-STYLE CROSSWALK, OR DIAGONALS-STYLE CROSSWALK)
- ⑧ THERMOPLASTIC PAVEMENT MARKING - LINE 24" (WHITE SOLID)
- ⑨ THERMOPLASTIC PAVEMENT MARKING - LETTERS & SYMBOLS (WHITE)
- ⑩ RAISED REFLECTIVE PAVEMENT MARKERS
- ⑪ PREFORMED PLASTIC PAVEMENT MARKING - LINE 7" (4" WHITE OVER 7" BLACK, 10'-30" SKIP LINE) GROOVING FOR RECESSED PAVEMENT MARKING, 8"
- ⑫ MODIFIED URETHANE PAVEMENT MARKING - LINE 6" (WHITE 2'-6" SKIP LINE)
- ⑬ MODIFIED URETHANE PAVEMENT MARKING - LINE 4" (YELLOW SOLID, DOUBLE CENTERLINE)
- ⑭ MODIFIED URETHANE PAVEMENT MARKING - LINE 12" (YELLOW DIAGONALS @ 45°, 75' SPACING UNLESS NOTED, 5 MIN.)
- ⑮ TRAFFIC BARRIER TERMINAL, TYPE 1 (SPECIAL) TANGENT
- ⑯ TRAFFIC BARRIER TERMINAL, TYPE 1 (SPECIAL) FLARED

MODEL Path: G:\Engineering\Live\Projects\1003\_IDOT\_DUB\_HBR\W01 - 62N43\CADD\CADD\_Sheets\CHRD\162N43-01-01-02.dwg



USER NAME = jdvais	DESIGNED - MA	REVISED -
	DRAWN - MA	REVISED -
PLOT SCALE = 100,0000' / in.	CHECKED - JJD	REVISED -
PLOT DATE = 4/26/2022	DATE - 03/18/2021	REVISED -

**STATE OF ILLINOIS  
DEPARTMENT OF TRANSPORTATION**

**RESURFACING AND PAVEMENT MARKING PLAN  
US 12 /20 /45 OVERLAY AND ADA RAMP IMPROVEMENTS**

SCALE: 1"=50'    SHEET 2 OF 3 SHEETS    STA. 40+00 TO STA. 68+00

F.A.P. RTE. 330	SECTION 2021-030-R5	COUNTY COOK	TOTAL SHEETS 35	SHEET NO. 10
CONTRACT NO. 62N43				
ILLINOIS FED. AID PROJECT 9P76(903)				

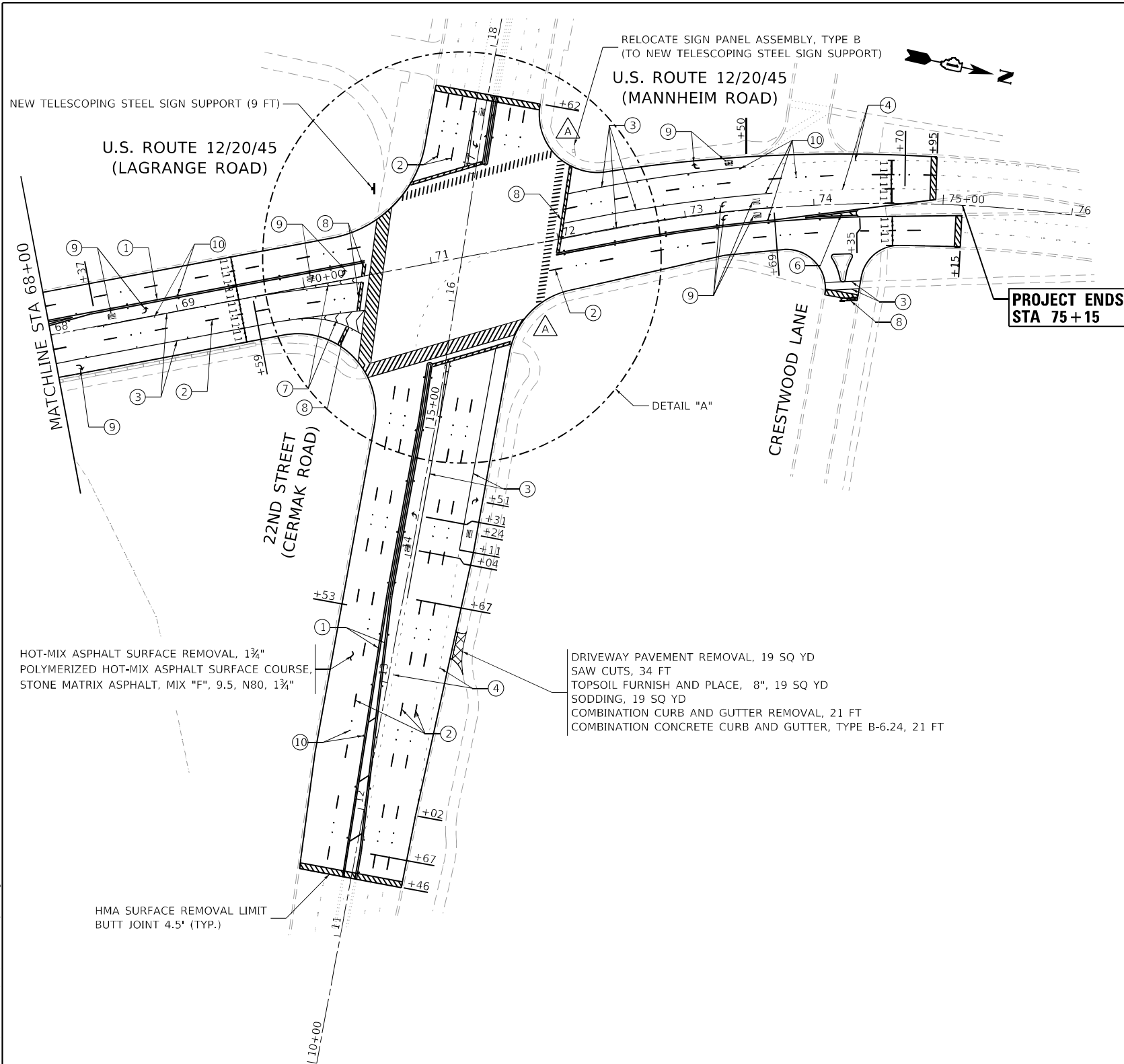

**NOTES:**

1. INSTALL PAVEMENT MARKINGS IN ACCORDANCE WITH DISTRICT ONE STANDARD DETAIL TC-13 - TYPICAL PAVEMENT MARKINGS. CROSSWALKS ARE 6' WIDE UNLESS OTHERWISE NOTED. STOP LINE SETBACK FROM ALL CROSSWALKS IS 4'.
2. INSTALL RAISED REFLECTIVE PAVEMENT MARKERS IN ACCORDANCE WITH DISTRICT ONE STANDARD DETAIL TC-11 - RAISED REFLECTIVE PAVEMENT MARKERS (SNOW-PLOW RESISTANT). OMIT RAISED REFLECTIVE MARKERS ON BRIDGE.

**SIDEWALK LEGEND**

- CURB RAMP IMPROVEMENT, SEE ADA CURB RAMP DETAILS PLAN
- CURB RAMP IMPROVEMENT, SEE PD-04A

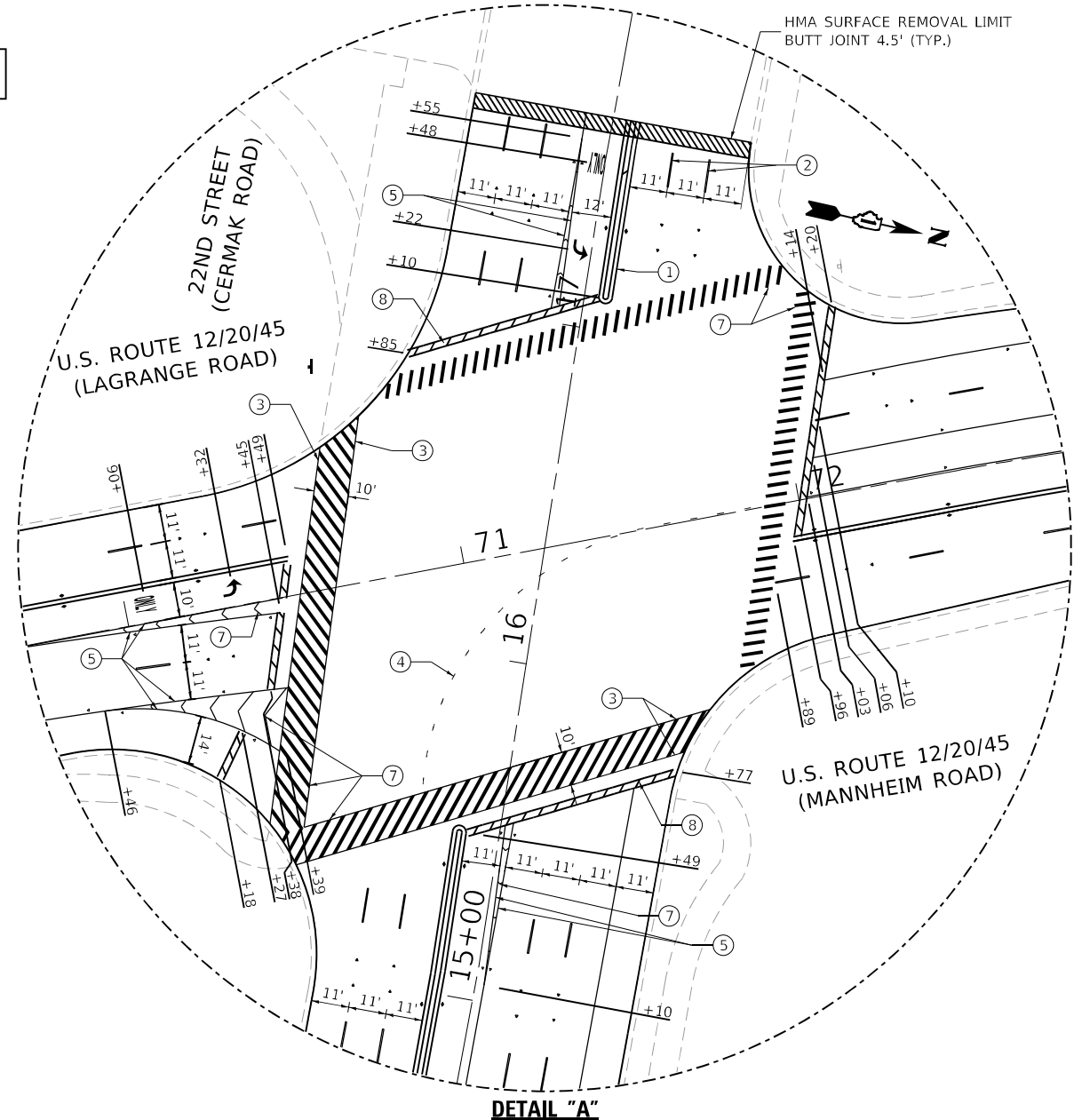

HOT-MIX ASPHALT SURFACE REMOVAL, 1 3/4"  
POLYMERIZED HOT-MIX ASPHALT SURFACE COURSE,  
STONE MATRIX ASPHALT, MIX "F", 9.5, N80, 1 3/4"

DRIVEWAY PAVEMENT REMOVAL, 19 SQ YD  
SAW CUTS, 34 FT  
TOPSOIL FURNISH AND PLACE, 8", 19 SQ YD  
SODDING, 19 SQ YD  
COMBINATION CURB AND GUTTER REMOVAL, 21 FT  
COMBINATION CONCRETE CURB AND GUTTER, TYPE B-6.24, 21 FT

**PAVEMENT MARKING LEGEND**

- THERMOPLASTIC PAVEMENT MARKING - LINE 4" (YELLOW SOLID, DOUBLE CENTERLINE)
- THERMOPLASTIC PAVEMENT MARKING - LINE 4" (WHITE 10'-30' SKIP LINE)
- THERMOPLASTIC PAVEMENT MARKING - LINE 6" (WHITE SOLID)
- THERMOPLASTIC PAVEMENT MARKING - LINE 6" (WHITE 2'-6' SKIP LINE)
- THERMOPLASTIC PAVEMENT MARKING - LINE 8" (WHITE SOLID)
- THERMOPLASTIC PAVEMENT MARKING - LINE 12" (YELLOW DIAGONALS @ 45°, 75' SPACING UNLESS NOTED, 5 MIN.)
- THERMOPLASTIC PAVEMENT MARKING - LINE 12" (WHITE CHEVRON @ 45°, CONTINENTAL-STYLE CROSSWALK, OR DIAGONALS-STYLE CROSSWALK)
- THERMOPLASTIC PAVEMENT MARKING - LINE 24" (WHITE SOLID)
- THERMOPLASTIC PAVEMENT MARKING - LETTERS & SYMBOLS (WHITE)
- RAISED REFLECTIVE PAVEMENT MARKERS
- PREFORMED PLASTIC PAVEMENT MARKING - LINE 7" (4" WHITE OVER 7" BLACK, 10'-30' SKIP LINE) GROOVING FOR RECESSED PAVEMENT MARKING, 8"

- MODIFIED URETHANE PAVEMENT MARKING - LINE 6" (WHITE 2'-6' SKIP LINE)
- MODIFIED URETHANE PAVEMENT MARKING - LINE 4" (YELLOW SOLID, DOUBLE CENTERLINE)
- MODIFIED URETHANE PAVEMENT MARKING - LINE 12" (YELLOW DIAGONALS @ 45°, 75' SPACING UNLESS NOTED, 5 MIN.)
- TRAFFIC BARRIER TERMINAL, TYPE 1 (SPECIAL) TANGENT
- TRAFFIC BARRIER TERMINAL, TYPE 1 (SPECIAL) FLARED

MODEL Path: G:\Engineering\Live\Projects\21003\_IDOT\_DUB\_HBR\WID - 62M43\CADD\CADD\_Sheets\CADD\62M43-2103-2103-2103-3.dwg



USER NAME = jldavis	DESIGNED - MA	REVISED -
PLOT SCALE = 100,0000' / in.	DRAWN - MA	REVISED -
PLOT DATE = 4/26/2022	CHECKED - JJD	REVISED -
	DATE - 03/18/2021	REVISED -

**STATE OF ILLINOIS  
DEPARTMENT OF TRANSPORTATION**

<b>RESURFACING AND PAVEMENT MARKING PLAN</b>	
<b>US 12 /20 /45 OVERLAY AND ADA RAMP IMPROVEMENTS</b>	
SCALE: 1"=50'	SHEET 3 OF 3 SHEETS
STA. 68+00	TO STA. 76+11

F.A.P. RTE. 330	SECTION 2021-030-R5	COUNTY COOK	TOTAL SHEETS 35	SHEET NO. 11
CONTRACT NO. 62N43				
ILLINOIS FED. AID PROJECT 9P76(903)				

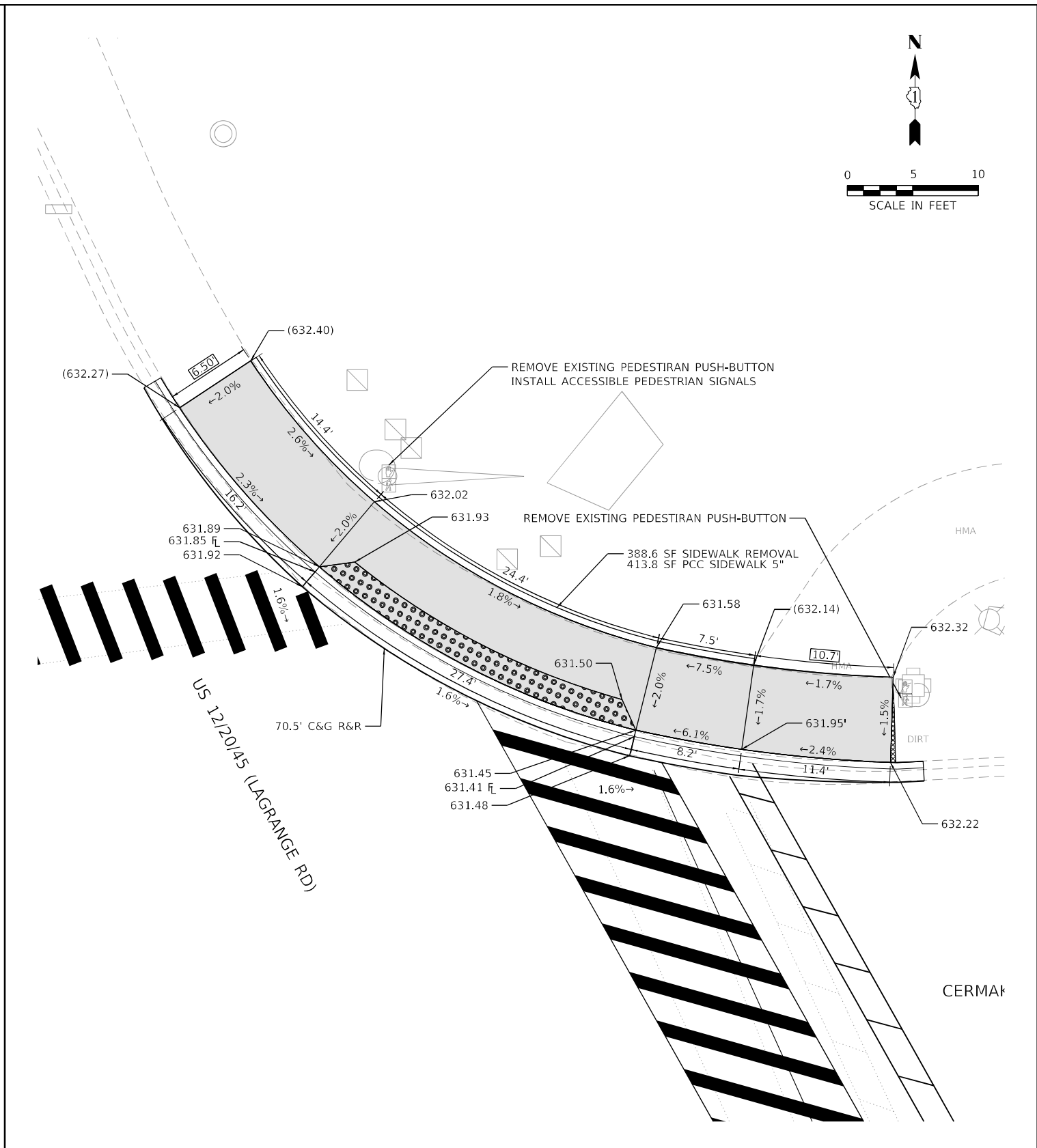
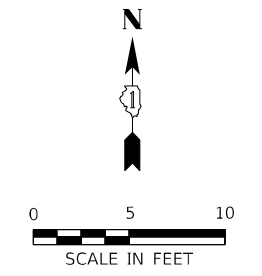
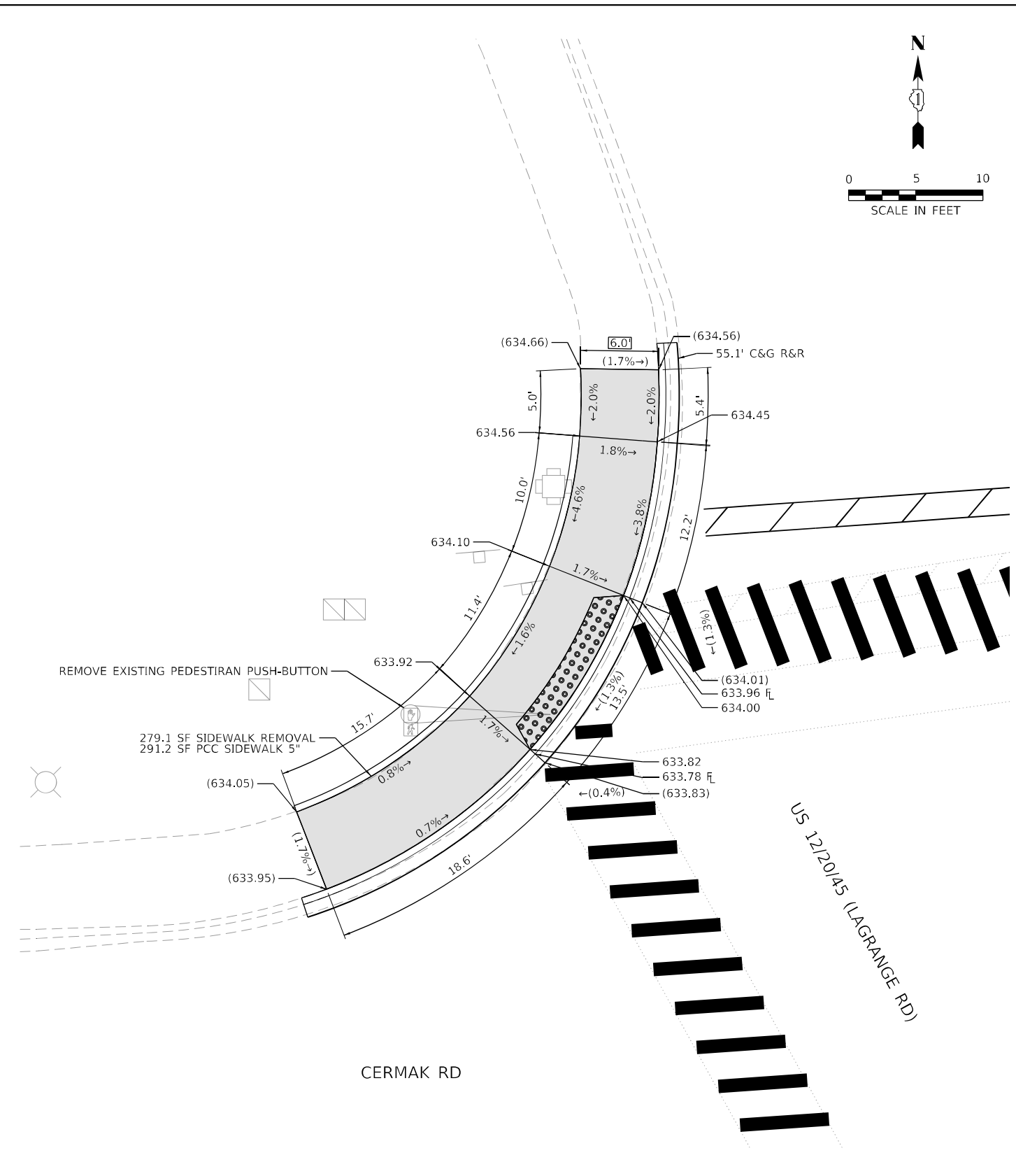
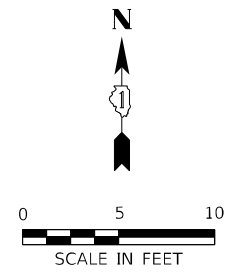

CP 1  
 GROUND MARKER WEST OF UTILITY POLE AT NORTHWEST CORNER OF LAGRANGE RD AND CERMAK RD  
 ELEVATION 635.05  
 NORTHING 1887812.469  
 EASTING 1107285.313

**LEGEND**

<span style="border: 1px solid black; padding: 2px;">XX.X'</span> EXISTING LENGTH	DETECTABLE WARNINGS	SIDEWALK REMOVAL, REPLACE WITH TOPSOIL & SOD
( ) EXISTING ELEVATION/SLOPE	PROPOSED SIDEWALK	
PROPOSED SIDE CURB		

CP 1  
 GROUND MARKER WEST OF UTILITY POLE AT NORTHWEST CORNER OF LAGRANGE RD AND CERMAK RD  
 ELEVATION 635.05  
 NORTHING 1887812.469  
 EASTING 1107285.313



USER NAME = jdavis	DESIGNED - JLS	REVISED -
	DRAWN - JLS	REVISED -
PLOT SCALE = 10,0000 * / in.	CHECKED - JJD	REVISED -
PLOT DATE = 4/26/2022	DATE - 03/18/2021	REVISED -

**STATE OF ILLINOIS  
 DEPARTMENT OF TRANSPORTATION**

**ADA CURB RAMP DETAILS – CERMAK RD  
 LAGRANGE RD SMART OVERLAY AND ADA RAMP IMPROVEMENTS**

SCALE: 1"=5'    SHEET 1 OF 1 SHEETS    STA.    TO STA.

F.A.P. RTE. 330	SECTION 2021-030-R5	COUNTY COOK	TOTAL SHEETS 35	SHEET NO. 12
CONTRACT NO. 62N43			ILLINOIS FED. AID PROJECT 9P76(903)	

MODEL: Default  
 FILE NAME: G:\Engineering\LiveProjects\21003\_IDOT\_DUB\_HBR\WID\_1 - 62N43\CADD\CADD\_Sheets\CURB\CP1\12-ADA-Cermaq\_Rd.dwg

# ADA DETAIL FOR SINGLE PERPENDICULAR CURB RAMPS W/ EXIST. 5% OR LESS RUN. SLOPE

**PD-01A**

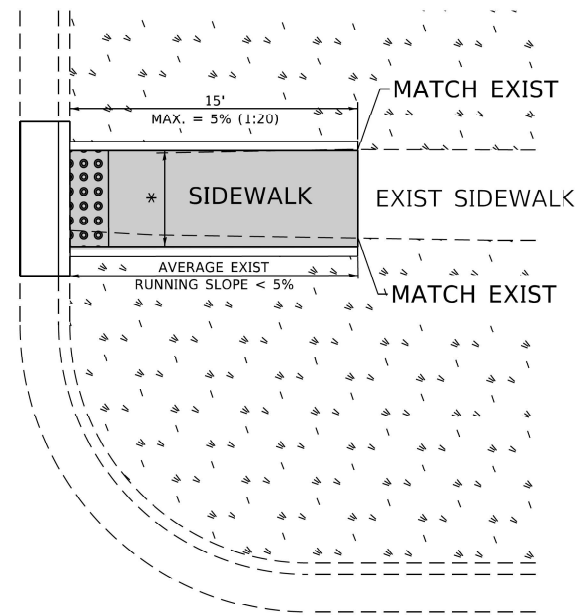

**PD-01B**

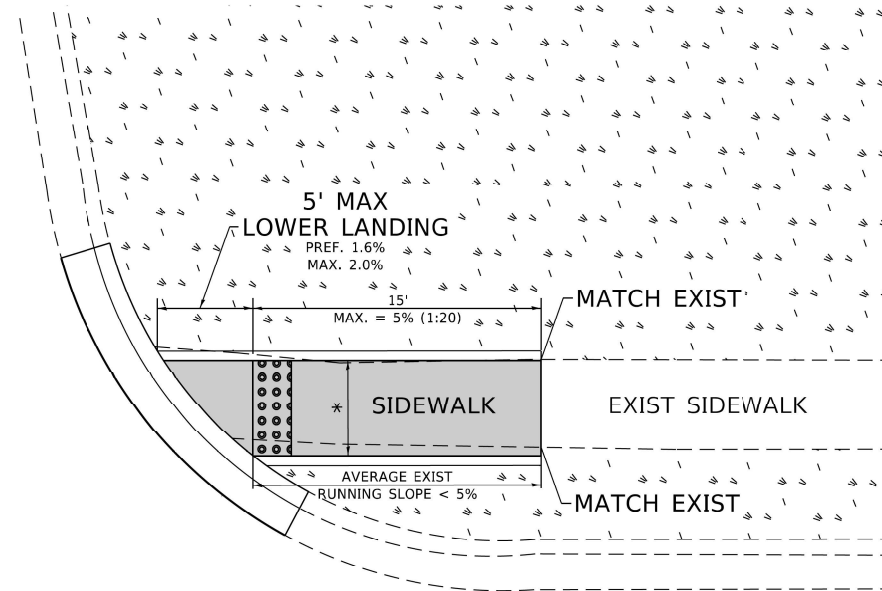

**PD-01C**

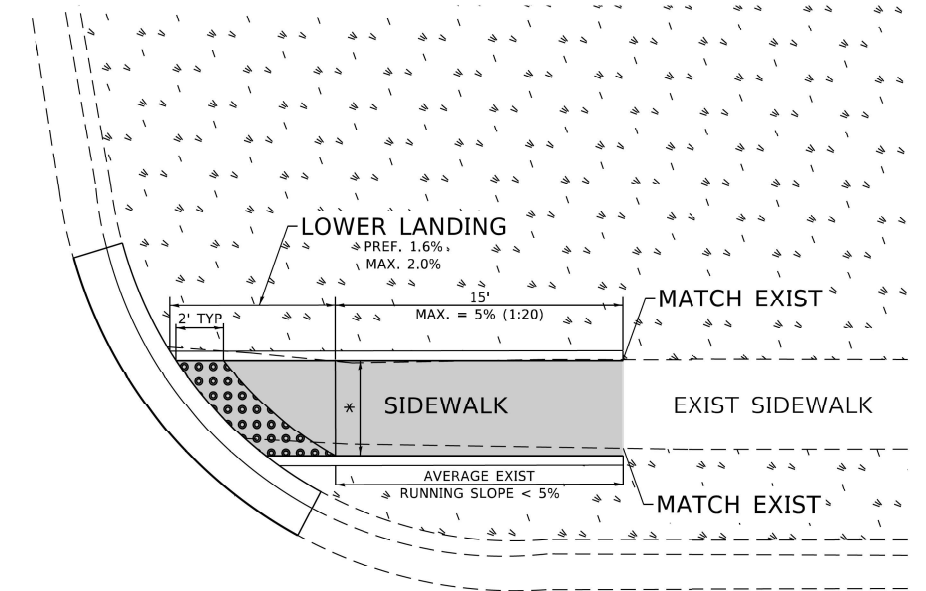

**LEGEND**

- PROPOSED SIDE CURB
- EXIST. GRASS
- PROPOSED SIDEWALK
- DETECTABLE WARNINGS

**CONSTRUCTION NOTES:**

- 1) ALL CROSS SLOPES ARE PREFERRED 1.6% (1:64), MAXIMUM 2% (1:50) EXCEPT WHEN TRANSITIONING TO EXISTING SIDEWALK
- \* MATCH EXISTING SIDEWALK WIDTH

MODEL: PD-01  
FILE NAME: C:\Engineering\Live\Projects\21003\_IDOT\_DUB\_HBRWID\_1 - 62N43\CADD\CADD\_Sheets\CURB\PD-01A-ADA-Project\_Details.dgn

USER NAME =	DESIGNED -	REVISED -
	DRAWN - R. LEDEZMA	REVISED -
PLOT SCALE = 100.0000' / in.	CHECKED -	REVISED -
PLOT DATE =	DATE - 10/02/2019	REVISED -

**STATE OF ILLINOIS  
DEPARTMENT OF TRANSPORTATION**

**PROJECT DETAIL FOR SINGLE PERPENDICULAR CURB RAMPS  
(PD-01)**

SCALE: NONE    SHEET    OF    SHEETS    STA.    TO STA.

F.A.P. RTE.	SECTION	COUNTY	TOTAL SHEETS	SHEET NO.
330	2021-030-R5	COOK	35	13
PD-01		CONTRACT NO. 62N43		
ILLINOIS FED. AID PROJECT 9P76(903)				

# ADA DETAIL FOR DOUBLE PERPENDICULAR CURB RAMPS

**PD-03A**

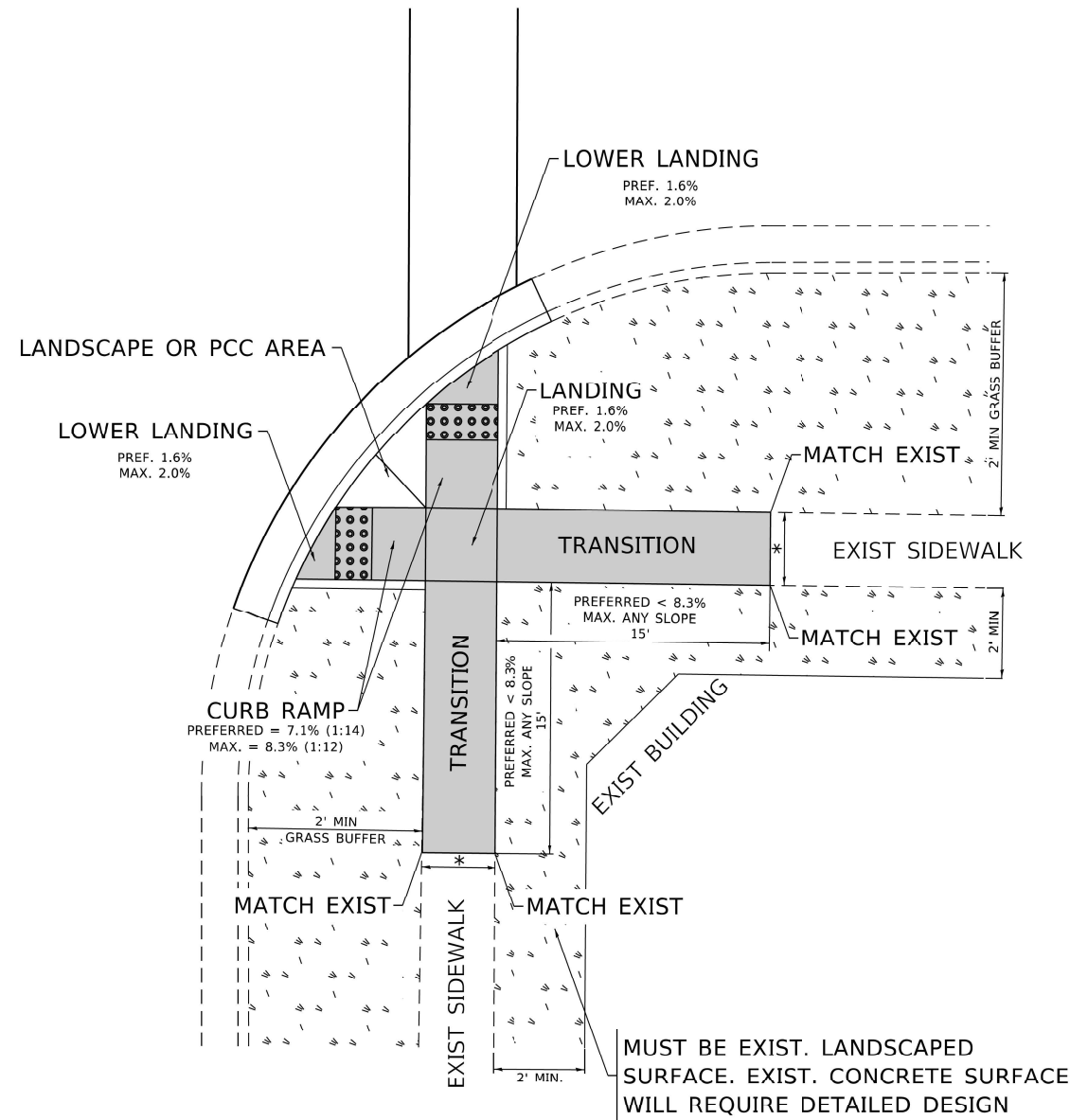

**PD-03B**

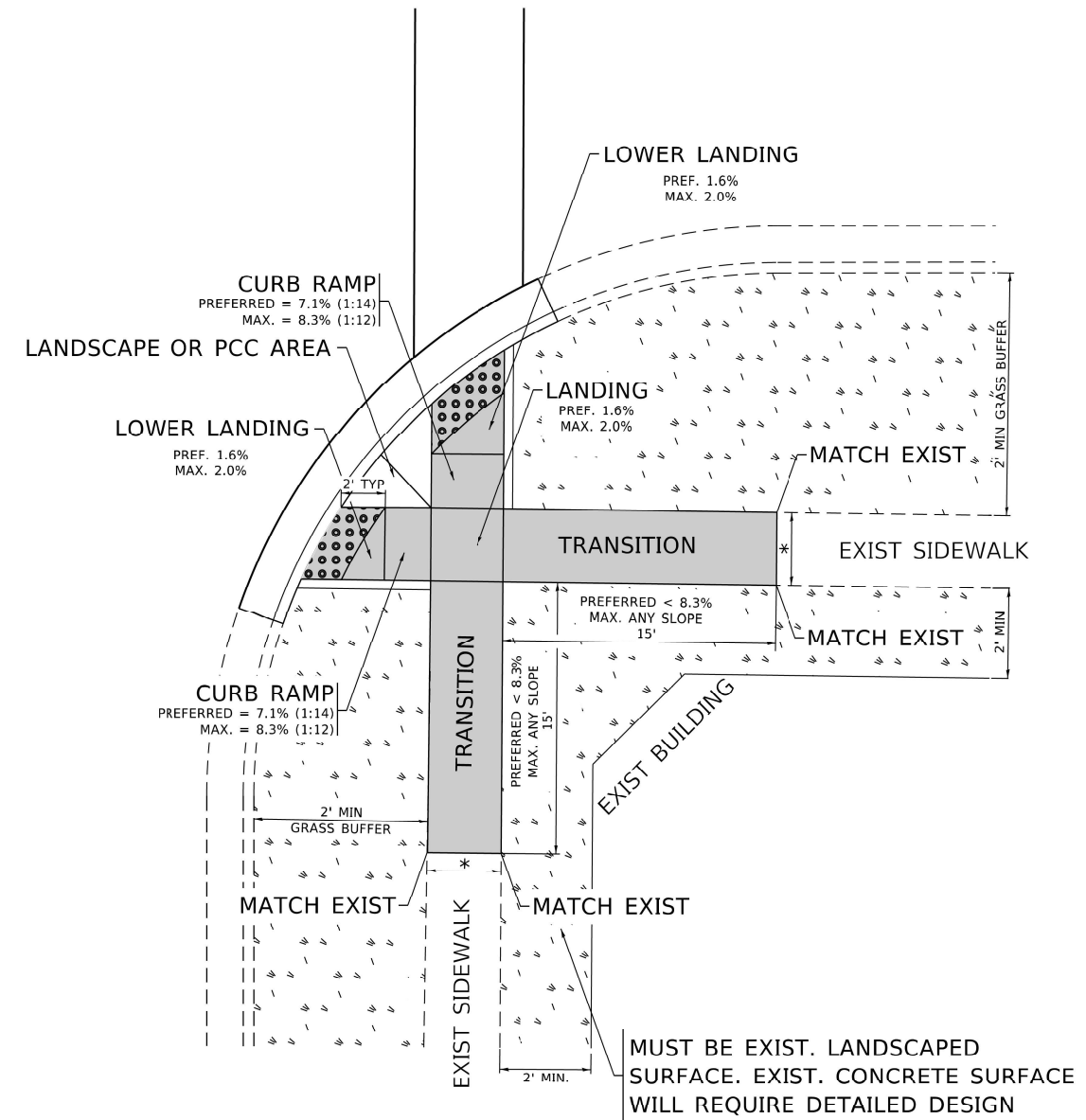

**LEGEND**

- EXIST. GRASS
- PROPOSED SIDEWALK
- DETECTABLE WARNINGS
- PROPOSED SIDE CURB

**CONSTRUCTION NOTES:**

- 1) ALL CROSS SLOPES ARE PREFERRED 1.6% (1:64), MAXIMUM 2% (1:50) EXCEPT WHEN TRANSITIONING TO EXISTING SIDEWALK
- \* MATCH EXISTING SIDEWALK WIDTH

MODEL: PD-03  
FILE NAME: C:\Engineering\Live\Projects\21003\_IDOT\_DUB\_HBR\WID - 62N43\CADD\CADD\_Sheets\CURB\PD-03A-CURB-Details.dwg

USER NAME =	DESIGNED -	REVISED -
	DRAWN - R. LEDEZMA	REVISED -
PLOT SCALE = 100.0000' / in.	CHECKED -	REVISED -
PLOT DATE =	DATE - 10/02/2019	REVISED -

**STATE OF ILLINOIS  
DEPARTMENT OF TRANSPORTATION**

**PROJECT DETAIL FOR DOUBLE PERPENDICULAR CURB RAMPS  
(PD-03)**

SCALE: NONE    SHEET    OF    SHEETS    STA.    TO STA.

F.A.P. RTE.	SECTION	COUNTY	TOTAL SHEETS	SHEET NO.
330	2021-030-R5	COOK	35	14
PD-03		CONTRACT NO. 62N43		
ILLINOIS   FED. AID PROJECT 9P76(903)				

# ADA DETAIL FOR SINGLE PERPENDICULAR CURB RAMPS W/ TURNING SPACE

**PD-04A**

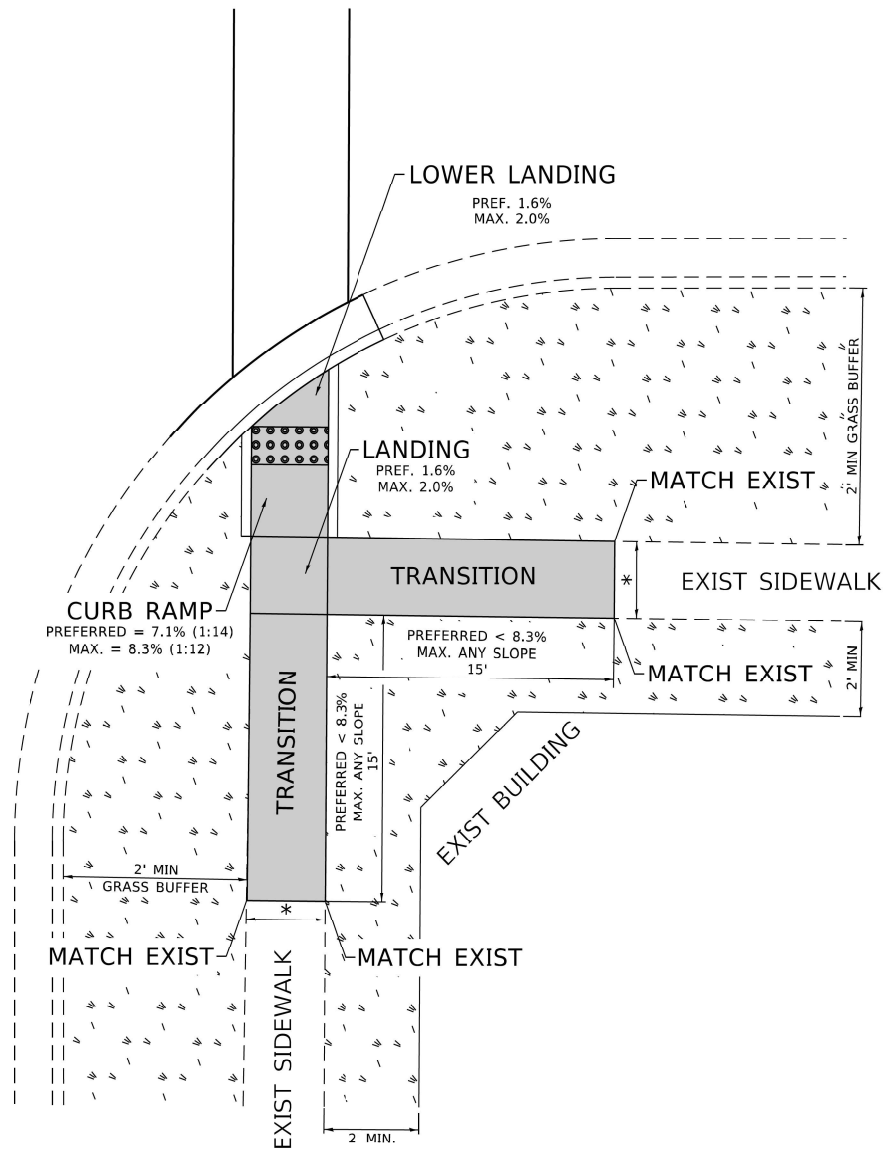

**PD-04B**

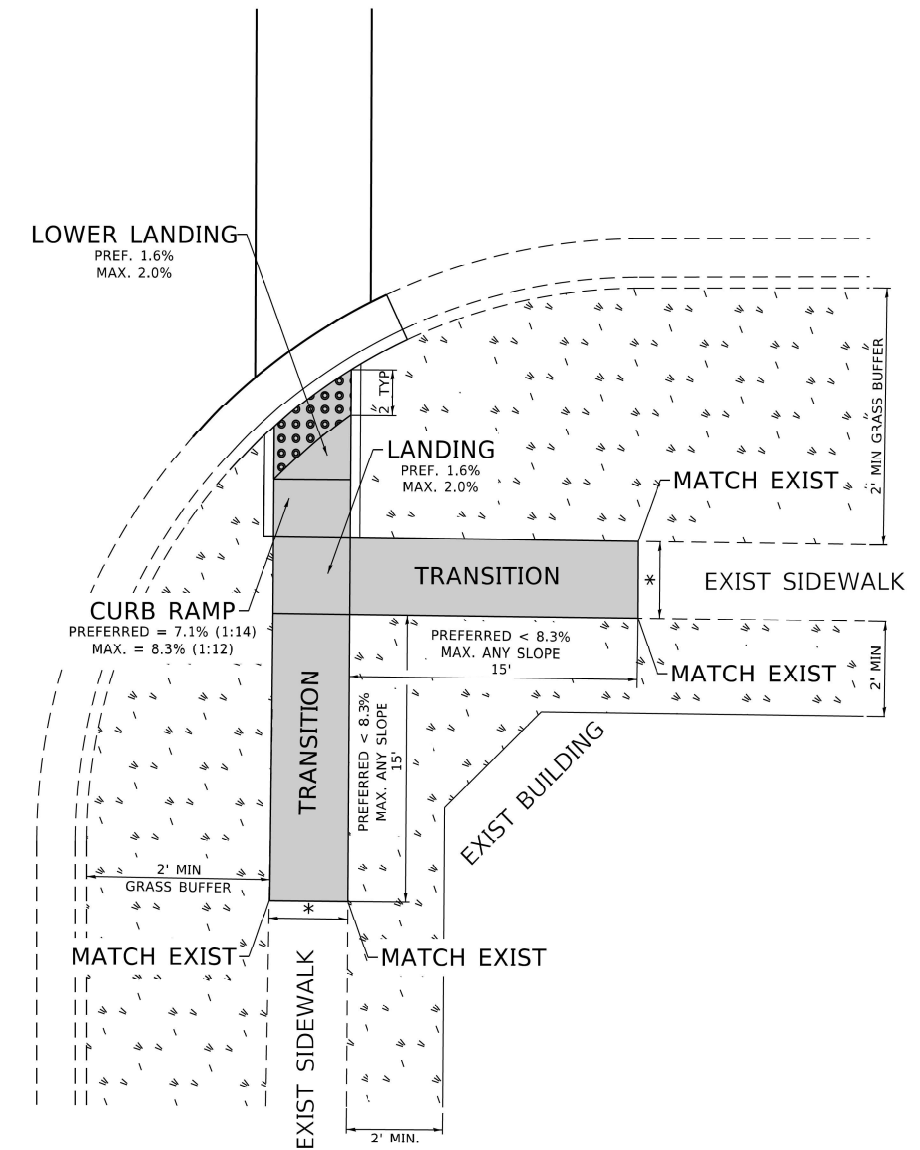

**LEGEND**

- EXIST. GRASS
- PROPOSED SIDEWALK
- DETECTABLE WARNINGS
- PROPOSED SIDE CURB

**CONSTRUCTION NOTES:**

- 1) ALL CROSS SLOPES ARE PREFERRED 1.6% (1:64), MAXIMUM 2% (1:50) EXCEPT WHEN TRANSITIONING TO EXISTING SIDEWALK
- \* MATCH EXISTING SIDEWALK WIDTH

MODEL: PD-04  
FILE: NAME: C:\Engineering\Live\Projects\21003\_IDOT\_DUB\_HBR\WID - 62N43\CADD\CADD\_Sheets\CURB\PD-04A\Project\_Details.dgn

USER NAME =	DESIGNED -	REVISED -
	DRAWN - R. LEDEZMA	REVISED -
PLOT SCALE = 100.0000' / in.	CHECKED -	REVISED -
PLOT DATE =	DATE - 10/02/2019	REVISED -

**STATE OF ILLINOIS  
DEPARTMENT OF TRANSPORTATION**

**PROJECT DETAIL FOR SINGLE PERPENDICULAR CURB RAMPS WITH  
TURNING SPACE (PD-04)**

SCALE: NONE    SHEET    OF    SHEETS    STA.    TO    STA.

F.A.P. RTE.	SECTION	COUNTY	TOTAL SHEETS	SHEET NO.
330	2021-030-R5	COOK	35	15
PD-04		CONTRACT NO. 62N43		
ILLINOIS FED. AID PROJECT 9P76(903)				

# ADA DETAIL FOR PARALLEL CURB RAMPS ADJACENT TO LANDSCAPING

**PD-06A**

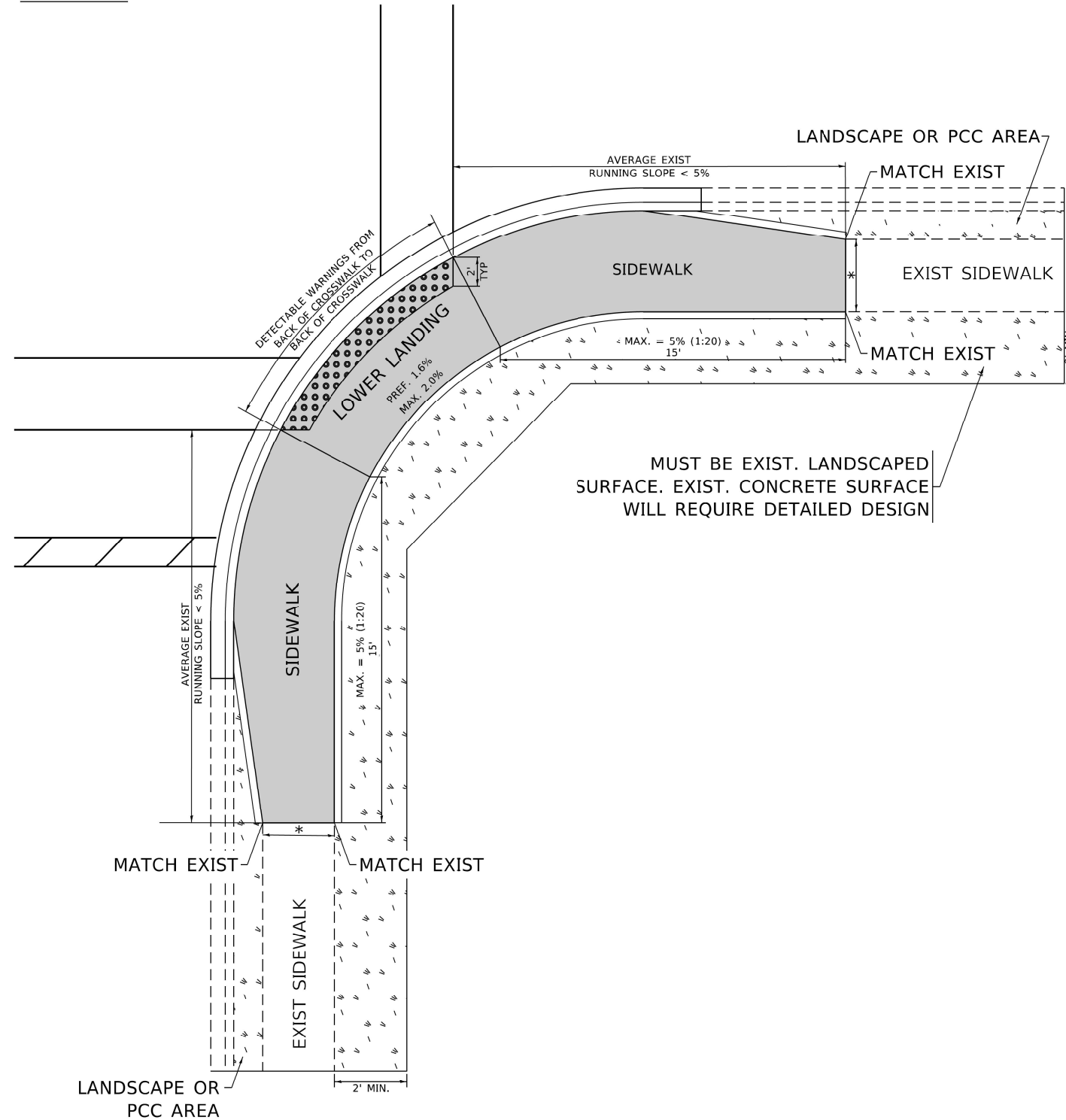

**PD-06B**

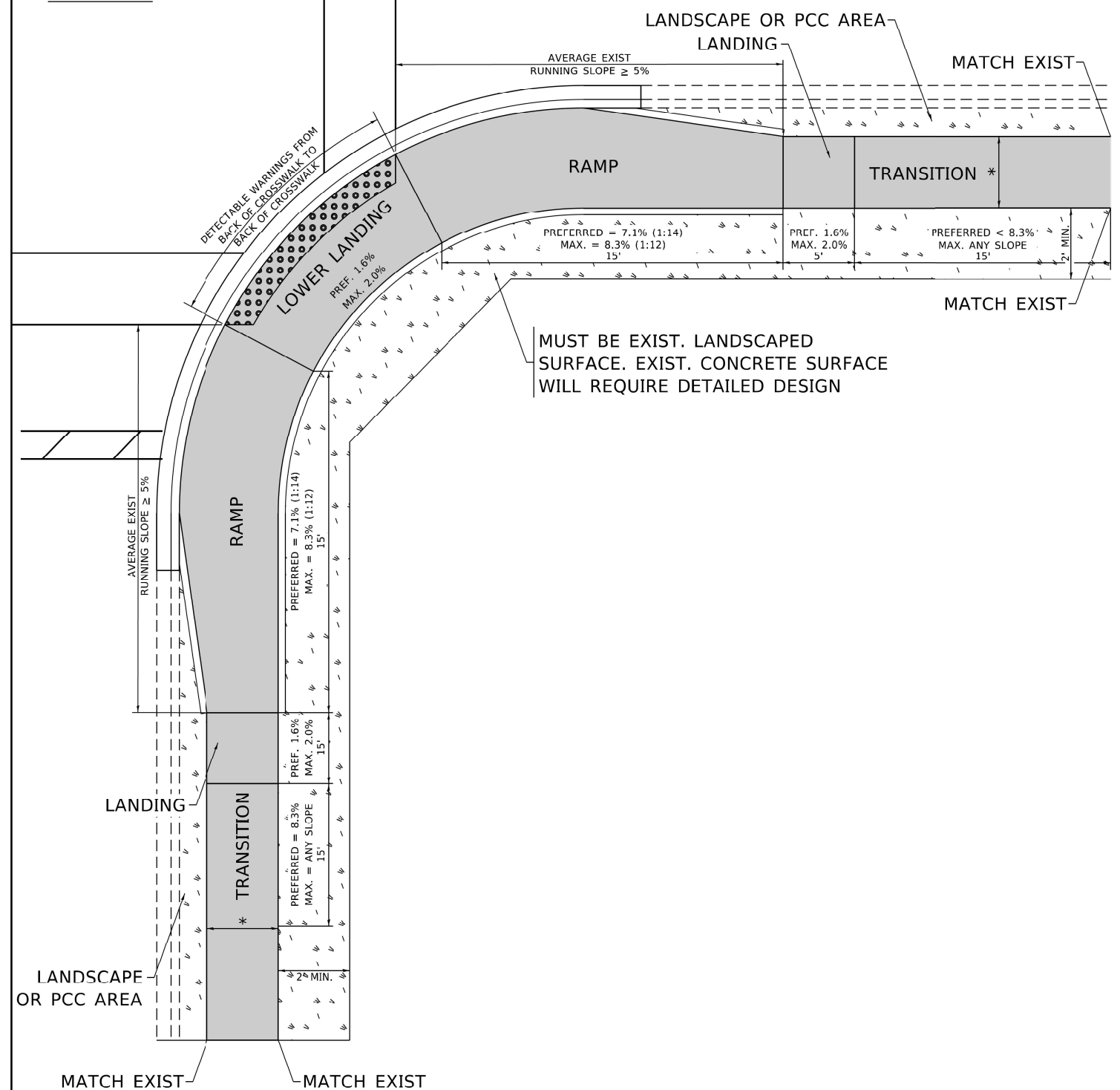

**LEGEND**

- EXIST. GRASS
- PROPOSED SIDEWALK
- DETECTABLE WARNINGS
- PROPOSED SIDE CURB

**CONSTRUCTION NOTES:**

- 1) ALL CROSS SLOPES ARE PREFERRED 1.6% (1:64), MAXIMUM 2% (1:50) EXCEPT WHEN TRANSITIONING TO EXISTING SIDEWALK
- \* MATCH EXISTING SIDEWALK WIDTH

MODEL: PD-06  
FILE: NAME: Co\_Engineering\LiveProject\21003\_IDOT\_DUB\_HBR\WID - 62N43\CADD\CADD\_Sheets\CURB\PD-06A.dwg

USER NAME =	DESIGNED -	REVISED -
	DRAWN - R. LEDEZMA	REVISED -
PLOT SCALE = 100.0000' / in.	CHECKED -	REVISED -
PLOT DATE =	DATE - 10/02/2019	REVISED -

**STATE OF ILLINOIS  
DEPARTMENT OF TRANSPORTATION**

**PROJECT DETAIL FOR PARALLEL CURB RAMPS  
(PD-06)**

SCALE: NONE    SHEET    OF    SHEETS    STA.    TO STA.

F.A.P. RTE.	SECTION	COUNTY	TOTAL SHEETS	SHEET NO.
330	2021-030-R5	COOK	35	16
PD-06		CONTRACT NO. 62N43		

ILLINOIS FED. AID PROJECT 9P76(903)



# TRAFFIC SIGNAL LEGEND

(NOT TO SCALE)

ITEM	EXISTING	PROPOSED	ITEM	EXISTING	PROPOSED	ITEM	EXISTING	PROPOSED
CONTROLLER CABINET			HANDHOLE -SQUARE -ROUND			SIGNAL HEAD -(P) PROGRAMMABLE SIGNAL HEAD		
COMMUNICATION CABINET			HEAVY DUTY HANDHOLE -SQUARE -ROUND			SIGNAL HEAD WITH BACKPLATE -(P) PROGRAMMABLE SIGNAL HEAD -(RB) RETROREFLECTIVE BACKPLATE		
MASTER CONTROLLER			DOUBLE HANDHOLE			PEDESTRIAN SIGNAL HEAD AT RAILROAD INTERSECTIONS		
MASTER MASTER CONTROLLER			JUNCTION BOX			PEDESTRIAN SIGNAL HEAD WITH COUNTDOWN TIMER		
UNINTERRUPTABLE POWER SUPPLY			RAILROAD CANTILEVER MAST ARM			ILLUMINATED SIGN "NO LEFT TURN"/"NO RIGHT TURN"		
SERVICE INSTALLATION -(P) POLE MOUNTED			RAILROAD FLASHING SIGNAL			NUMBER OF CONDUCTORS, ELECTRIC CABLE NO. 14, UNLESS NOTED OTHERWISE. ALL DETECTOR LOOP CABLE TO BE SHIELDED		
SERVICE INSTALLATION -(G) GROUND MOUNTED -(GM) GROUND MOUNTED METERED			RAILROAD CROSSING GATE			GROUND CABLE IN CONDUIT, NO. 6 SOLID COPPER (GREEN)		
TELEPHONE CONNECTION			RAILROAD CROSSBUCK			ELECTRIC CABLE IN CONDUIT, TRACER NO. 14 1/C		
STEEL MAST ARM ASSEMBLY AND POLE			RAILROAD CONTROLLER CABINET			COAXIAL CABLE		
ALUMINUM MAST ARM ASSEMBLY AND POLE			UNDERGROUND CONDUIT (UC), GALVANIZED STEEL			VENDOR CABLE		
STEEL COMBINATION MAST ARM ASSEMBLY AND POLE WITH LUMINAIRE			TEMPORARY SPAN WIRE, TETHER WIRE, AND CABLE			COPPER INTERCONNECT CABLE, NO. 18, 3 PAIR TWISTED, SHIELDED		
SIGNAL POST -(BM) BARREL MOUNTED - TEMPORARY			SYSTEM ITEM	S	SP	FIBER OPTIC CABLE -NO. 62.5/125, MM12F -NO. 62.5/125, MM12F SM12F -NO. 62.5/125, MM12F SM24F		
WOOD POLE			INTERSECTION ITEM	I	IP	GROUND ROD -(C) CONTROLLER -(M) MAST ARM -(P) POST -(S) SERVICE		
GUY WIRE			REMOVE ITEM		R			
SIGNAL HEAD			RELOCATE ITEM		RL			
SIGNAL HEAD WITH BACKPLATE			ABANDON ITEM		A			
SIGNAL HEAD OPTICALLY PROGRAMMED			CONTROLLER CABINET AND FOUNDATION TO BE REMOVED		RCF			
FLASHER INSTALLATION -(FS) SOLAR POWERED			MAST ARM POLE AND FOUNDATION TO BE REMOVED		RMF			
PEDESTRIAN SIGNAL HEAD			SIGNAL POST AND FOUNDATION TO BE REMOVED		RPF			
PEDESTRIAN PUSH BUTTON -(APS) ACCESSIBLE PEDESTRIAN PUSH BUTTON			DETECTOR LOOP, TYPE I					
RADAR DETECTION SENSOR			PREFORMED DETECTOR LOOP					
VIDEO DETECTION CAMERA			SAMPLING (SYSTEM) DETECTOR					
RADAR/VIDEO DETECTION ZONE			INTERSECTION AND SAMPLING (SYSTEM) DETECTOR					
PAN, TILT, ZOOM (PTZ) CAMERA			QUEUE AND SAMPLING (SYSTEM) DETECTOR					
EMERGENCY VEHICLE LIGHT DETECTOR			WIRELESS DETECTOR SENSOR					
CONFIRMATION BEACON			WIRELESS ACCESS POINT					
WIRELESS INTERCONNECT								
WIRELESS INTERCONNECT RADIO REPEATER								

MODEL: TS-05  
 FILE NAME: C:\Engineering\116\Project\116\1003\_IDOT\_DUB\_HDB\116\_62N43\CADD\CADD\_Sheets\CADD\163\163-04-08F\_S043.dwg

USER NAME = footemj	DESIGNED - IP	REVISED -	
	DRAWN - IP	REVISED -	
PLOT SCALE = 50.0000' / in.	CHECKED - LP	REVISED -	
PLOT DATE = 3/4/2019	DATE - 9/29/2016	REVISED -	

**STATE OF ILLINOIS  
DEPARTMENT OF TRANSPORTATION**

**DISTRICT ONE  
STANDARD TRAFFIC SIGNAL DESIGN DETAILS**

SCALE: NONE    SHEET 1 OF 7 SHEETS    STA. TO STA.

F.A.P. RTE.	SECTION	COUNTY	TOTAL SHEETS	SHEET NO.
330	2021-030-R5	COOK	35	17
<b>TS-05</b>			CONTRACT NO. 62N43	
ILLINOIS   FED. AID PROJECT 9P76(903)				

**LOOP DETECTOR NOTES**

1. EACH PAIR OF LOOP WIRES SHALL BE PLACED IN A SEPARATE EMPTY COILABLE NONMETALLIC CONDUIT FROM THE EDGE OF PAVEMENT TO THE HANDHOLE. SPACING BETWEEN THE HOLES DRILLED IN THE PAVEMENT SHALL NOT BE LESS THAN 6" (150 mm). EMPTY COILABLE NONMETALLIC CONDUIT SHALL BE INCLUDED IN THE COST OF THE LOOP WIRE.
2. THE NUMBER OF LOOP TURNS SHALL BE AS RECOMMENDED BY THE AMPLIFIER MANUFACTURER. ALL ADJACENT SIDES OF THE LOOPS SHALL BE INSTALLED IN SUCH A WAY THAT THE CURRENT FLOW IS IN THE SAME DIRECTION TO REINFORCE ITS MAGNETIC FIELDS FOR SMALL VEHICLE DETECTION.
3. EACH LOOP LEAD-IN SHALL BE IDENTIFIED AND PERMANENTLY TAGGED IN THE HANDHOLE. EACH LEAD-IN CABLE TAG SHALL INDICATE THE LOCATION OF THE LOOP, LOOP ROTATION (CLOCKWISE/COUNTERCLOCKWISE), LOOP LEAD-IN DIRECTION (IN OR OUT), LOOP CABLE NUMBER AND LOCATION IN CABINET, AND NUMBER OF TURNS IN THE DETECTOR LOOPS IN WATER PROOF INK AS INDICATED ON THE DISTRICT 1 STANDARD TRAFFIC SIGNAL DESIGN DETAIL. THE CONTRACTOR SHALL MARK LOOP LOCATIONS ON RECORD DRAWINGS AND PRESENT TO THE ENGINEER AFTER FINAL INSPECTION. LOOPS SHALL BE MARKED BY LANE AND LOOP NUMBER. SEE DETAIL BELOW.
4. ALL LOOP CABLE SHALL BE FASTENED WITH PLASTIC TIE WRAP TO THE HANDHOLE HOOKS.
5. IN ASPHALT PAVEMENT, LOOPS SHOULD BE PLACED IN THE BINDER AND DIVESHOLES MARKED AT THE CURB WITH A SAW-CUT. THE SAW-CUT SHALL BE CUT IN ACCORDANCE WITH LOCAL AND E.P.A. DUST CONTROL REQUIREMENTS. DETECTOR LOOP(S) SHALL NOT BE INSTALLED IN WET CONDITIONS AND THE SAW-CUTS MUST BE FREE OF DEBRIS AND RESIDUE SUCH AS DUST AND WATER WHICH IS TO BE ACHIEVED BY THE USE OF COMPRESSED AIR, WIRE BRUSHING AND HEAT DRYING ACCORDING TO SEALANT MANUFACTURER REQUIREMENTS. THE DETECTOR WIRE SHALL BE HELD IN PLACE BY THE USE OF FORM WEDGES. WEDGES SHALL BE SPACED NO MORE THAN 18" (450 mm) APART.
6. LOOP SPLICES SHALL BE SOLDERED USING A SOLDERING IRON. BLOW TORCHES OR OTHER DEVICES WHICH OXIDIZE COPPER CABLE SHALL NOT BE ALLOWED FOR SOLDERING OPERATIONS. SEE DETAIL BELOW RIGHT.
7. PREFORMED DETECTOR LOOPS SHALL BE USED, AS SHOWN ON THE PLANS, WHERE NEW CONCRETE PAVEMENT IS PROPOSED. THE INSTALLATION OF PREFORMED LOOPS SHALL BE IN ACCORDANCE WITH THE DISTRICT 1 SPECIFICATIONS OR AS DIRECTED BY THE ENGINEER.

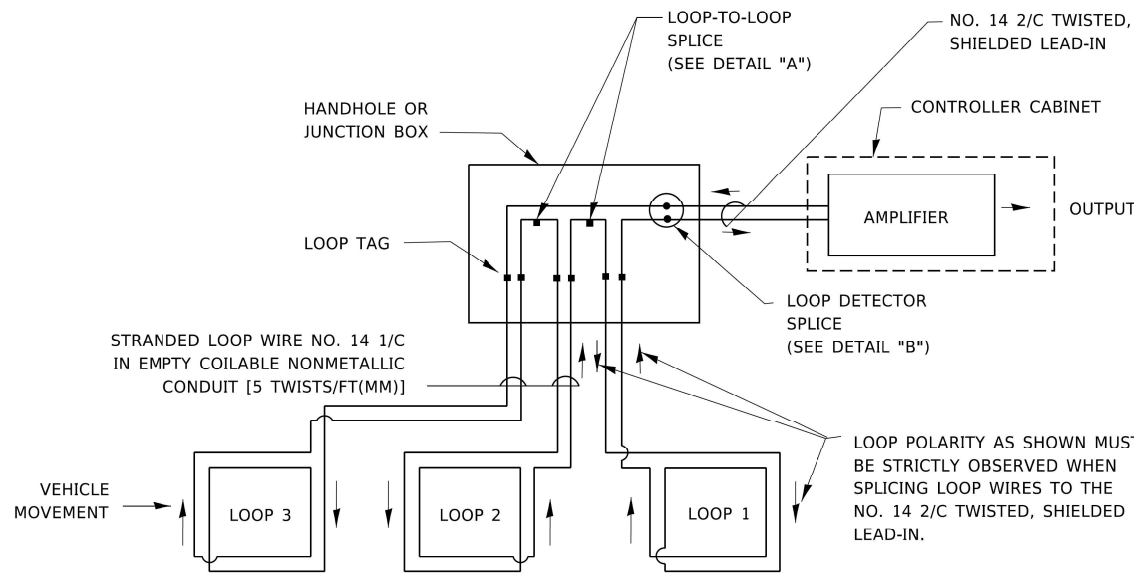

**DETECTOR LOOP WIRING SCHEMATIC**

- LOOPS SHALL BE SPLICED IN SERIES. SAW-CUTS SHALL BE A MINIMUM WIDTH OF 5/16" (8 mm).
- SAW-CUT DEPTHS SHALL BE 3" (75 mm). IF IN CONCRETE,
- THE SAW-CUT DEPTH SHALL BE TO THE TOP OF THE REINFORCEMENT.
- LOOP CORNERS SHALL BE DRILLED WITH A 2" (50 mm) DIAMETER CORE.

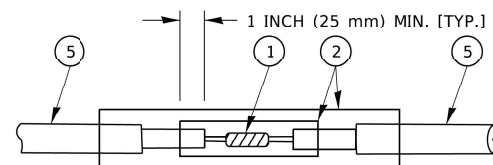

DETAIL "A"  
LOOP-TO-LOOP SPLICE

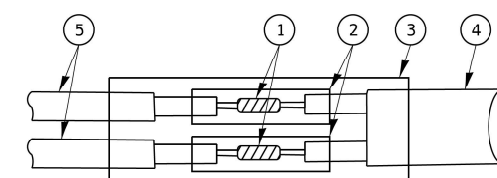

DETAIL "B"  
LOOP-TO-CONTROLLER SPLICE

**TYPE I LOOP**

**LOOP LEAD-IN CABLE TAG**

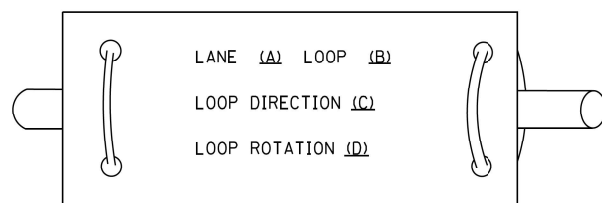

- A. LANE 1 IS THE LANE CLOSEST TO THE CENTERLINE OF THE ROADWAY
- B. LOOP #1 IS THE LOOP IN THE LANE CLOSEST TO THE INTERSECTION.
- C. LABEL LOOP CABLE "IN" OR LOOP CABLE "OUT".
- D. LABEL LOOP CABLE CLOCKWISE OR LOOP CABLE COUNTERCLOCKWISE.

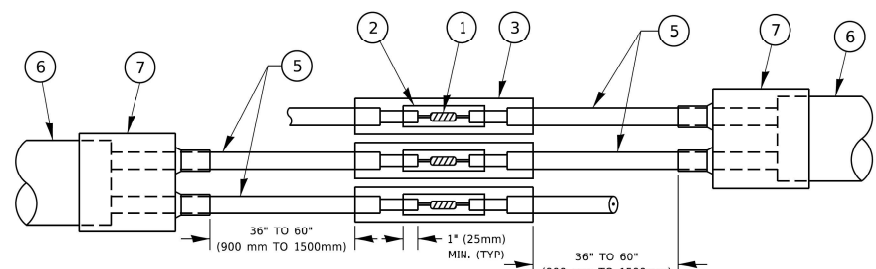

DETAIL "A"  
LOOP-TO-LOOP SPLICE

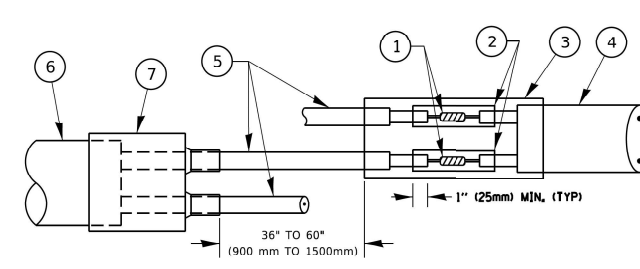

DETAIL "B"  
LOOP-TO-CONTROLLER SPLICE

**PREFORMED LOOP**

**LOOP DETECTOR SPLICE**

- ① WESTERN UNION SPLICE SOLDERED WITH ROSIN CORE FLUX. ALL EXPOSED SURFACES OF THE SOLDER SHALL BE SMOOTH. THE WESTERN UNION SPLICES SHALL BE STAGGERED.
- ② WCSMW 30/100 HEAT SHRINK TUBE, MINIMUM LENGTH 3" (75 mm), UNDERWATER GRADE.
- ③ WCS 200/750 HEAT SHRINK TUBE, MINIMUM LENGTH 6" (150 mm), UNDERWATER GRADE.
- ④ NO. 14 2/C TWISTED, SHIELDED CABLE.
- ⑤ LOOP CONDUCTOR WITH FLEXIBLE PLASTIC TUBE. PREFORMED LOOP
- ⑥ XL POLYOLEFIN 2 CONDUCTOR
- ⑦ BREAKOUT SEALS. TYCO CBR-2 OR APPROVED EQUAL

MODEL: TS-05; FILE: NAME: C:\Engineering\Live\Projects\21003\_IDOT\_DUB\_HBR\WID\_1\_62N43\CADD\CADD\_Sheets\CADD\_162N43-2103-2103-05E\_Sheet1.dwg

USER NAME = footemj	DESIGNED -	REVISED -
PLOT SCALE = 50.0000 "/in.	DRAWN -	REVISED -
PLOT DATE = 3/4/2019	CHECKED -	REVISED -
	DATE -	REVISED -

**STATE OF ILLINOIS  
DEPARTMENT OF TRANSPORTATION**

**DISTRICT ONE  
STANDARD TRAFFIC SIGNAL DESIGN DETAILS**

SCALE: NONE SHEET 2 OF 7 SHEETS STA. TO STA.

F.A.P. RTE. 330	SECTION 2021-030-R5	COUNTY COOK	TOTAL SHEETS 35	SHEET NO. 18
TS-05		CONTRACT NO. 62N43		
ILLINOIS FED. AID PROJECT 9P76(903)				

**TRAFFIC SIGNAL MAST ARM AND SIGNAL POST**

MAST ARM MOUNTED SIGNALS IN EXISTING, PROPOSED OR FUTURE SIDEWALK/BICYCLE PATH AREA. INTERSECTION SHOWN WITH PEDESTRIAN SIGNALS AND PEDESTRIAN PUSHBUTTON DETECTORS.

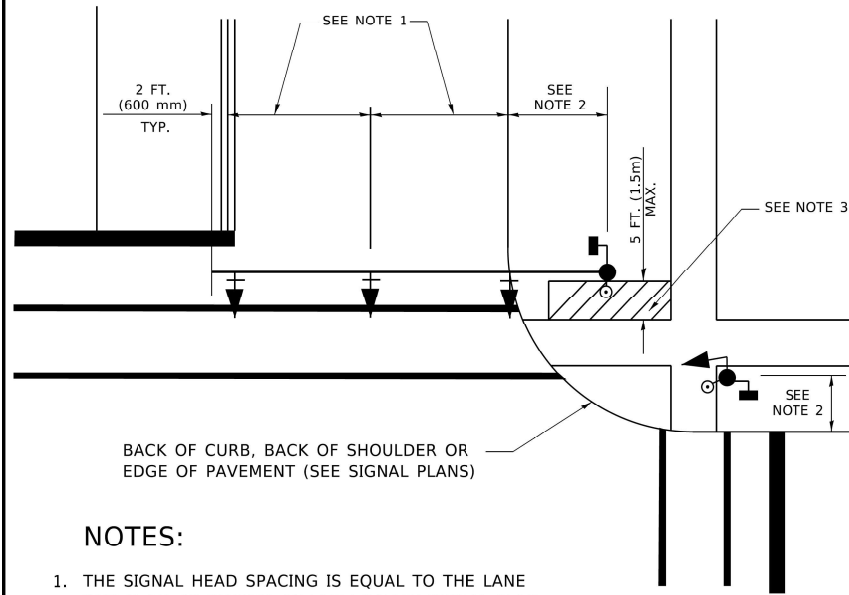

**NOTES:**

1. THE SIGNAL HEAD SPACING IS EQUAL TO THE LANE WIDTH OR AS SHOWN ON THE TRAFFIC SIGNAL PLAN.
2. REFER TO THE TRAFFIC SIGNAL EQUIPMENT OFFSET TABLE.
3. PROVIDE A LEVEL ALL-WEATHER SURFACE (CONCRETE SIDEWALK, ASPHALT BICYCLE PATH SURFACE OR MATCHING MATERIAL TO THE ADJACENT SURFACE) UP TO THE MAST ARM SHAFT OR THE SIGNAL POST.
4. THE FACE OF THE PEDESTRIAN PUSHBUTTON SHALL BE PARALLEL TO THE CROSSWALK TO BE USED.
5. THE LOCATIONS AND INSTALLATION OF PEDESTRIAN SIGNAL HEADS AND PEDESTRIAN PUSHBUTTONS SHALL MEET THE REQUIREMENTS OF THE MUTCD AND INFORMATION FOUND IN THE "AMERICANS WITH DISABILITIES ACT ACCESSIBILITY GUIDELINES FOR BUILDINGS AND FACILITIES."

**PEDESTRIAN SIGNAL POST AND PEDESTRIAN PUSH BUTTON POST**

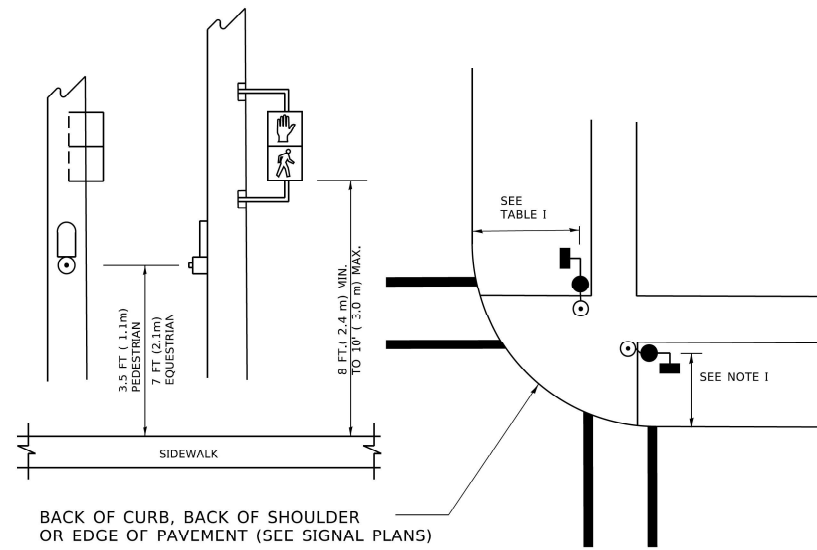

**NOTES:**

1. REFER TO THE TRAFFIC SIGNAL EQUIPMENT OFFSET TABLE.
2. PROVIDE A LEVEL ALL-WEATHER SURFACE (CONCRETE SIDEWALK, ASPHALT BICYCLE PATH SURFACE OR MATCHING MATERIAL TO THE ADJACENT SURFACE) UP TO THE PEDESTRIAN SIGNAL POST OR THE PEDESTRIAN PUSH BUTTON POST.
3. THE FACE OF THE PEDESTRIAN PUSHBUTTON SHALL BE PARALLEL TO THE CROSSWALK TO BE USED.
4. THE LOCATIONS AND INSTALLATION OF PEDESTRIAN SIGNAL HEADS AND PEDESTRIAN PUSHBUTTONS SHALL MEET THE REQUIREMENTS OF THE MUTCD AND INFORMATION FOUND IN THE "AMERICANS WITH DISABILITIES ACT ACCESSIBILITY GUIDELINES FOR BUILDINGS AND FACILITIES."

**RECOMMENDED PUSHBUTTON LOCATIONS**

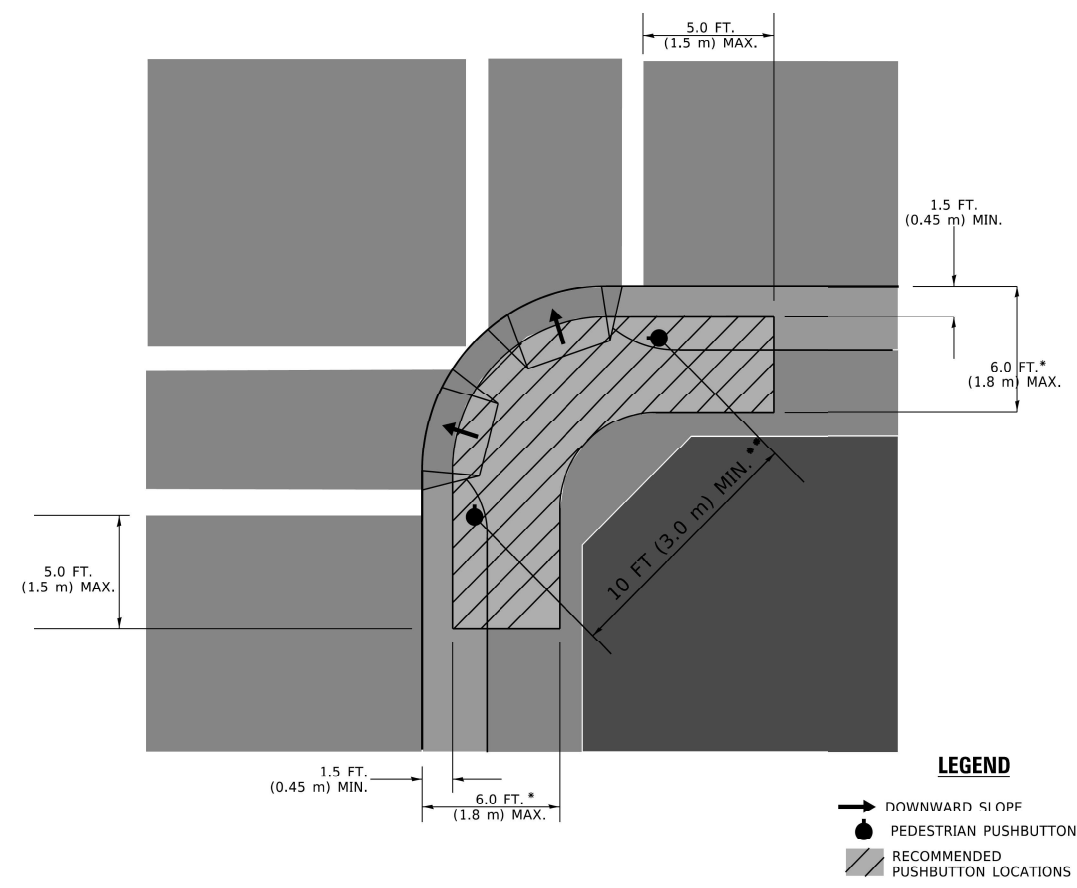

**LEGEND**

- DOWNWARD SLOPE
- PEDESTRIAN PUSHBUTTON
- RECOMMENDED PUSHBUTTON LOCATIONS

\* WHERE THERE ARE CONSTRAINTS THAT MAKE IT IMPRACTICAL TO PLACE THE PEDESTRIAN PUSHBUTTON BETWEEN 1.5 FT (0.45 m) AND 6 FT ( 1.8 m) FROM THE EDGE OF THE CURB, SHOULDER, OR PAVEMENT, IT SHOULD NOT BE FURTHER THAN 10 FT (3 m) FROM THE EDGE OF CURB, SHOULDER, OR PAVEMENT.

\*\* WHERE THERE ARE CONSTRAINTS ON A PARTICULAR CORNER THAT MAKE IT IMPRACTICAL TO PROVIDE THE 10 FT (3 m) SEPERATION BETWEEN THE TWO PEDESTRIAN PUSHBUTTONS, THE PUSHBUTTONS MAY BE PLACED CLOSER TOGETHER OR ON THE SAME POLE.

**NOTES:**

1. PEDESTRIAN SIGNAL HEADS SHALL BE MOUNTED WITH THE BOTTOM OF THE SIGNAL HOUSING INCLUDING BRACKETS NOT LESS THAN 8 FT (2.4 m) OR MORE THAN 10 FT (3 m) ABOVE SIDEWALK LEVEL, AND SHALL BE POSITIONED AND ADJUSTED TO PROVIDE MAXIMUM VISIBILITY AT THE BEGINNING OF THE CONTROLLED CROSSWALK.
2. THE BOTTOM OF THE SIGNAL HOUSING (INCLUDING BRACKETS) OF A VEHICULAR SIGNAL FACE THAT IS NOT LOCATED OVER A HIGHWAY SHALL BE AT LEAST 8 FT (2.4 m) BUT NOT MORE THAN 19 FT (5.8 m) ABOVE THE SIDEWALK OR, IF THERE IS NO SIDEWALK, ABOVE THE PAVEMENT GRADE AT THE CENTER OF THE ROADWAY.
3. THE BOTTOM OF THE SIGNAL HOUSING AND ANY RELATED ATTACHMENTS TO A SIGNAL FACE LOCATED OVER ANY PORTION OF A HIGHWAY SHALL BE ACCORDING TO CURRENT STATE STANDARDS 877001, 877002, 877006, 877011 AND 877012 WITH A MINIMUM OF 16 FT (5.0 m) AND A MAXIMUM OF 18 FT. (5.5 m) FROM THE HIGHEST POINT OF PAVEMENT.
4. THE BOTTOM OF THE TEMPORARY SPAN WIRE MOUNTED SIGNAL HOUSING AND ANY RELATED ATTACHMENTS TO A SIGNAL FACE LOCATED OVER ANY PORTION OF A HIGHWAY SHALL BE ACCORDING TO CURRENT STATE STANDARD 880001 WITH A MINIMUM OF 17 FT (5.18 m) FROM THE HIGHEST POINT OF PAVEMENT.
5. THE TOP OF THE SIGNAL HOUSING OF A SIGNAL FACE LOCATED OVER ANY PORTION OF A HIGHWAY SHALL NOT BE MORE THAN 25.6 FT (7.8 m) ABOVE THE PAVEMENT.

**TRAFFIC SIGNAL EQUIPMENT OFFSET**

TRAFFIC SIGNAL EQUIPMENT	COMBINATION CONCRETE CURB AND GUTTER (MINIMUM DISTANCE FROM BACK OF CURB TO CENTERLINE OF FOUNDATION)	SHOULDER/NON-CURBED AREA (MINIMUM DISTANCE FROM EDGE OF PAVEMENT TO CENTERLINE OF FOUNDATION)
TRAFFIC SIGNAL MAST ARM POLE	6 FT (1.8m)	SHOULDER WIDTH + 2 FT (0.6m), MINIMUM 10 FT (3.0m)
TRAFFIC SIGNAL POST	4 FT (1.2m)	SHOULDER WIDTH + 2 FT (0.6m), MINIMUM 10 FT (3.0m)
PEDESTRIAN SIGNAL POST	4 FT (1.2m)	SHOULDER WIDTH + 2 FT (0.6m), MINIMUM 10 FT (3.0m)
PEDESTRIAN PUSHBUTTON POST	4 FT (1.2m)	SHOULDER WIDTH + 2 FT (0.6m), MINIMUM 10 FT (3.0m)
TEMPORARY WOOD POLE	6 FT (1.0m)	SHOULDER WIDTH + 2 FT (0.6m), MINIMUM 10 FT (3.0m)
CONTROLLER CABINET	6 FT (1.8m) MINIMUM DISTANCE SEE NOTE 2	SHOULDER WIDTH + 6 FT (1.8m), MINIMUM 16 FT (4.9m) SEE NOTE 3.
SERVICE INSTALLATION, GROUND MOUNT	6 FT (1.8m) MINIMUM DISTANCE SEE NOTE 2	SHOULDER WIDTH + 6 FT (1.8m), MINIMUM 16 FT (4.9m) SEE NOTE 3.

**NOTES:**

1. CONTACT THE "AREA TRAFFIC SIGNAL MAINTENANCE AND OPERATIONS ENGINEER" FOR ASSISTANCE IN LOCATING THE TRAFFIC SIGNAL EQUIPMENT WHEN THERE ARE CONFLICTS WITH DITCHES OR THE MINIMUM OFFSET DISTANCES CANNOT BE MET.
2. MINIMUM DISTANCE FROM THE DACK OF CURD TO THE ROADWAY SIDE OF THE FOUNDATION.
3. MINIMUM DISTANCE FROM THE EDGE OF PAVEMENT TOTHE ROADWAY SIDE OF THE FOUNDATION.
4. ANY CHANGES TO THE OFFSETS OF THE FOUNDATIONS, FROM THE MINIMUM DISTANCES LISTED IN THE "TRAFFIC SIGNAL EQUIPMENT OFFSET" CHART AND THE TRAFFIC SIGNAL INSTALLATION PLAN, COULD EFFECT THE PLACEMENT OF THE SIGNAL HEADS, PEDESTRIAN SIGNAL HEADS AND THE PEDESTRIAN PUSHBUTTONS. THE SIGNAL HEAD PLACEMENT ON THE MAST ARMS SHALL REMAIN AS PER THE TRAFFIC SIGNAL INSTALLATION PLAN AND THE "TRAFFIC SIGNAL MAST ARM AND SIGNAL POST" DETAIL ABOVE. THE PROPOSED MAST ARM LENGTHS MAY NEED TO BE REVISED TO MEET THE ABOVE REQUIREMENTS. THE PEDESTRIAN SIGNAL HEADS AND PEDESTRIAN PUSHBUTTONS MUST MEET THE REQUIREMENTS UNDER THE DETAILS ON THIS SHEET.

MODEL: TS-05; FILE NAME: C:\Engineering\Live\Projects\1003\_IDOT\_DUB\_HBR\1003\_IDOT\_DUB\_HBR\1003\_Sheet\CI\RD\162\162-103-01R\_S04.dwg

USER NAME = footemj	DESIGNED -	REVISED -
PLOT SCALE = 50.0000' / in.	DRAWN -	REVISED -
PLOT DATE = 3/4/2019	CHECKED -	REVISED -
	DATE -	REVISED -

**STATE OF ILLINOIS  
DEPARTMENT OF TRANSPORTATION**

**DISTRICT ONE  
STANDARD TRAFFIC SIGNAL DESIGN DETAILS**

SCALE: NONE SHEET 3 OF 7 SHEETS STA. TO STA.

F.A.P. RTE.	SECTION	COUNTY	TOTAL SHEETS	SHEET NO.
330	2021-030-R5	COOK	35	19
<b>TS-05</b>		CONTRACT NO. 62N43		
ILLINOIS FED. AID PROJECT 9P76(903)				

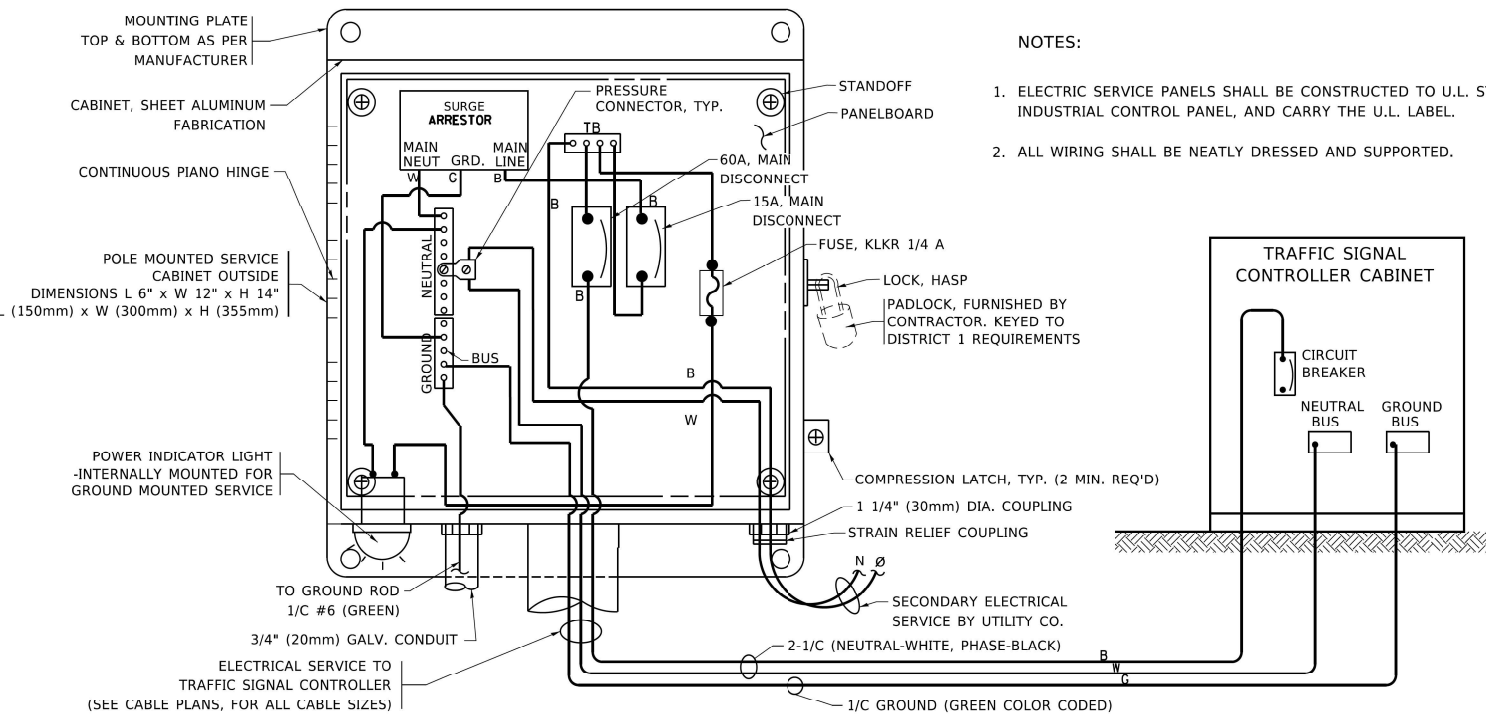

**ELECTRICAL SERVICE - PANEL DIAGRAM (TYPICAL FOR POLE AND GROUND MOUNTED SERVICE)**  
**SERVICE INSTALLATION POLE MOUNT (SHOWN)**  
 (NOT TO SCALE)

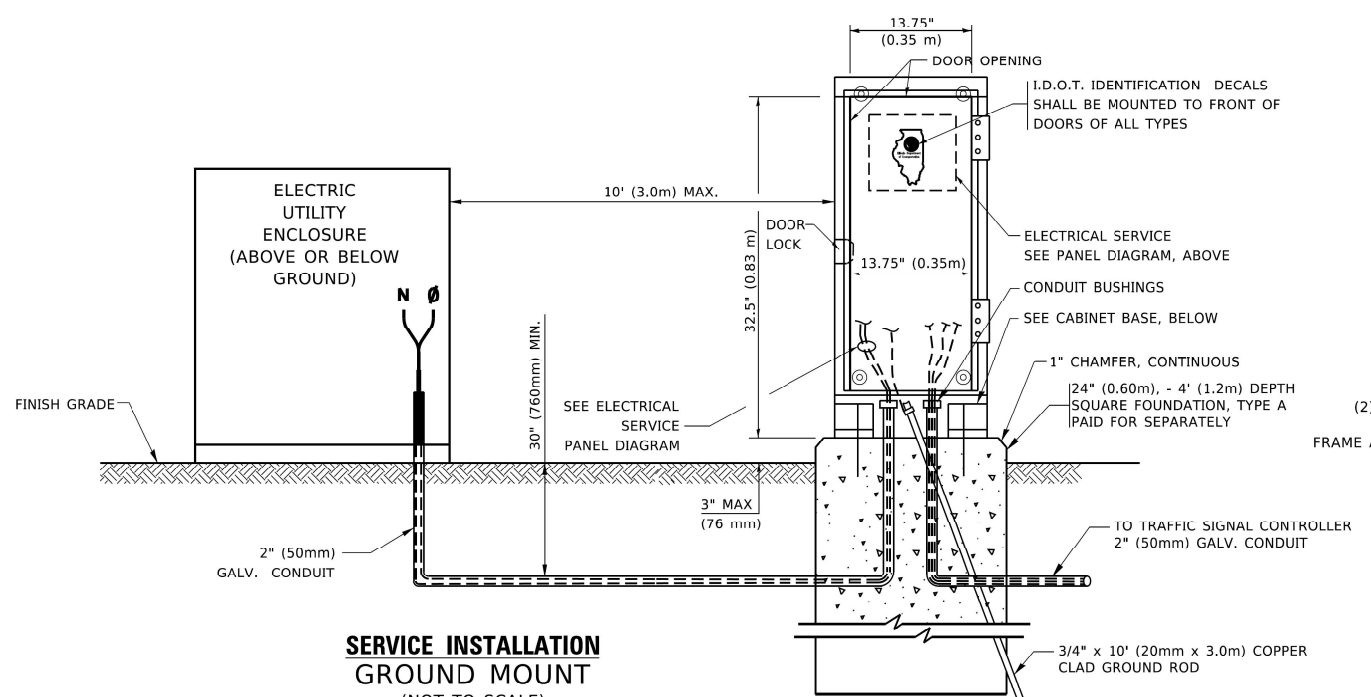

**SERVICE INSTALLATION GROUND MOUNT**  
 (NOT TO SCALE)

**CABINET - BASE BOLT PATTERN**  
 (NOT TO SCALE)

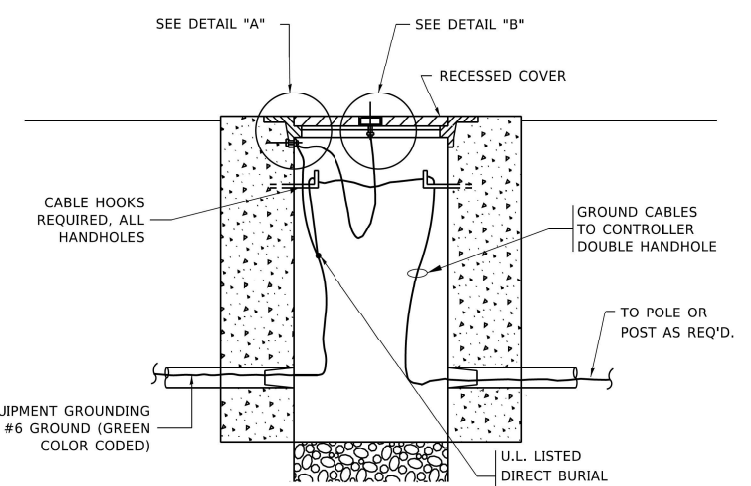
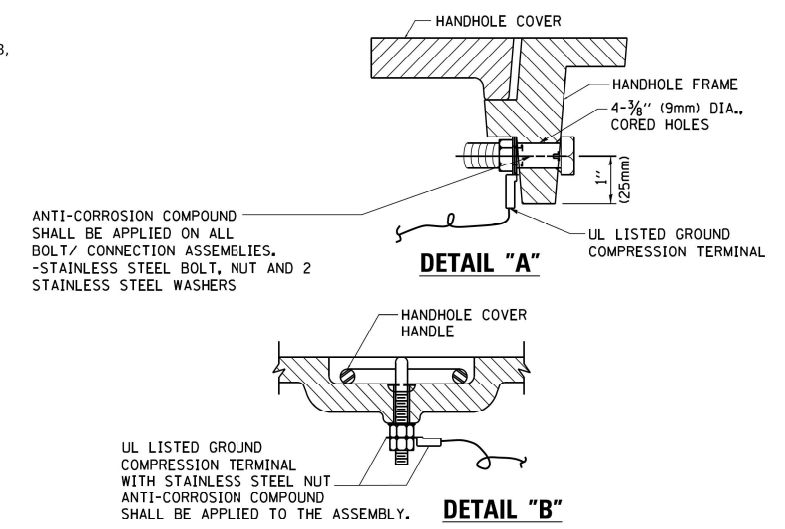

**HANDHOLE COVER & FRAME - GROUNDING DETAIL**  
 (NOT TO SCALE)

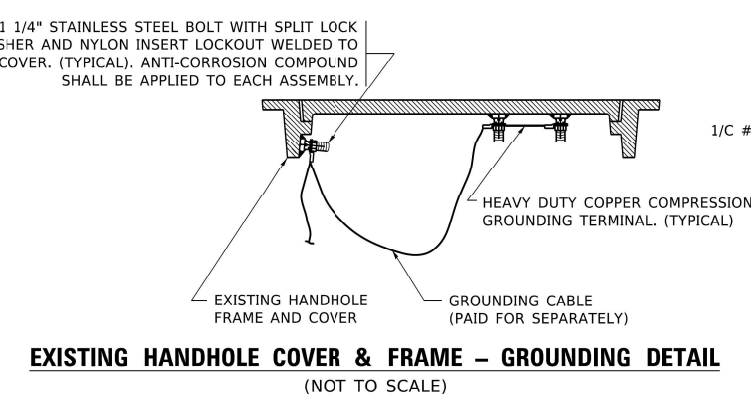

**EXISTING HANDHOLE COVER & FRAME - GROUNDING DETAIL**  
 (NOT TO SCALE)

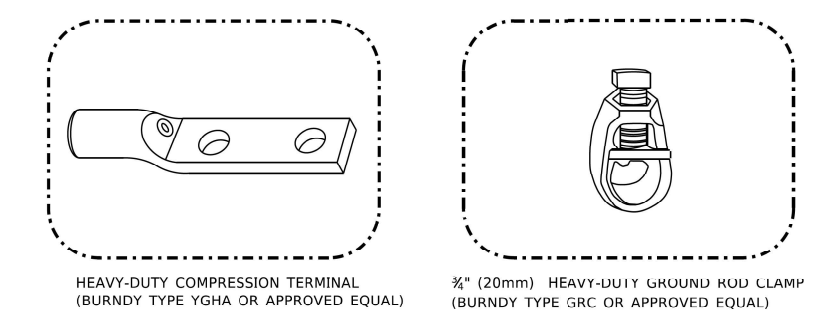

- NOTES:**
- ALL CLAMPS SHALL BE BRONZE OR COPPER, UL APPROVED.
  - GROUND CABLE SHALL BE LOOPED OVER HOOKS IN THE HANDHOLES
  - 6.5' (2.0m) SLACK SHALL BE PROVIDED IN SINGLE HANDHOLES
  - 13' (4.0m) OF SLACK SHALL BE PROVIDED IN DOUBLE HANDHOLES.
  - 5' (1.4m) OF SLACK SHALL BE PROVIDED BETWEEN FRAME AND COVER.

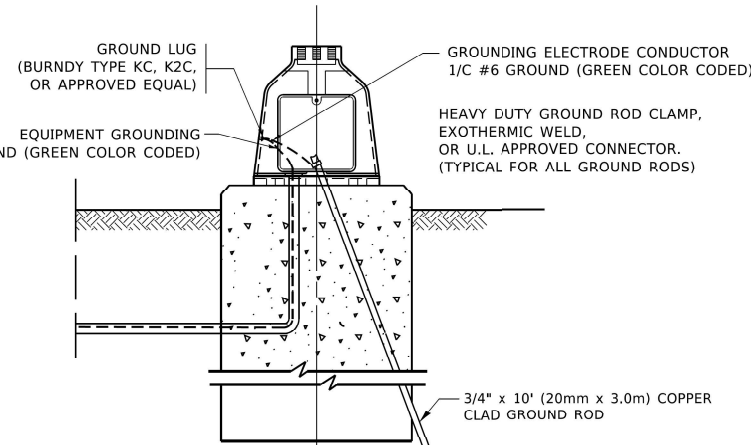

**MAST ARM POLE /POST-GROUNDING DETAIL**  
 (NOT TO SCALE)

MODEL: TS-05.dwg FILE NAME: C:\Engineering\Live\Projects\21003\_IDOT\_DUB\_HBR\WID - 62N43\CADD\CADD\_Sheets\CADD\62N43-05.dwg

USER NAME = footemj	DESIGNED -	REVISED -
PLOT SCALE = 50.0000' / in.	DRAWN -	REVISED -
PLOT DATE = 3/4/2019	CHECKED -	REVISED -
	DATE -	REVISED -

**STATE OF ILLINOIS  
 DEPARTMENT OF TRANSPORTATION**

<b>DISTRICT ONE</b>			
<b>STANDARD TRAFFIC SIGNAL DESIGN DETAILS</b>			
SCALE: NONE	SHEET 4	OF 7 SHEETS	STA. TO STA.

F.A.P. RTE.	SECTION	COUNTY	TOTAL SHEETS	SHEET NO.
330	2021-030-R5	COOK	35	20
<b>TS-05</b>		CONTRACT NO. 62N43		
ILLINOIS FED. AID PROJECT 9P76(903)				

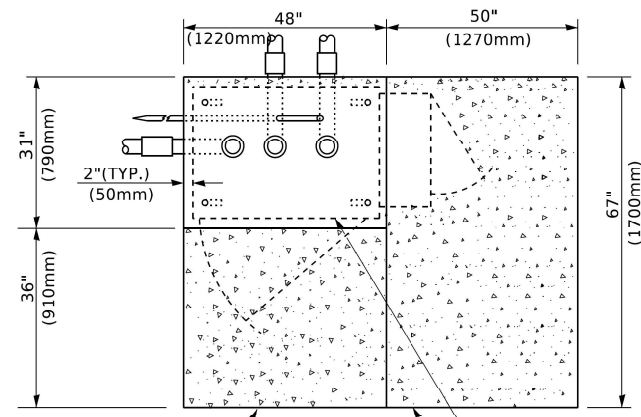

**TOP VIEW**

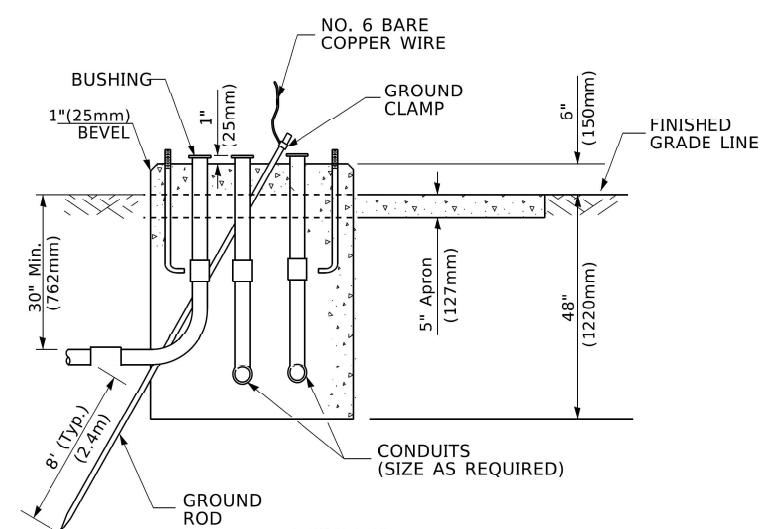

**TYPE D  
FOR GROUND MOUNTED  
CONTROLLER CABINET  
AND UPS BATTERY CABINET**

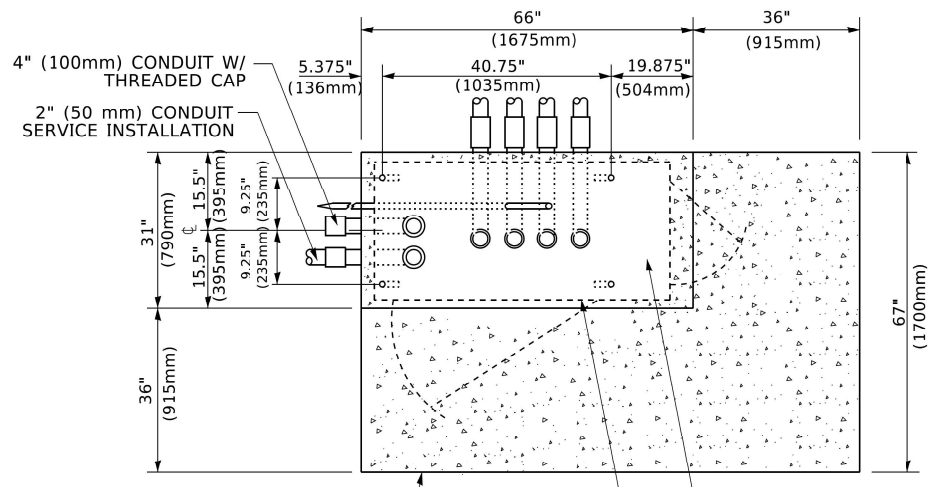

**TOP VIEW**

**NOTE:**  
TOP OF FOUNDATION SHALL BE HIGHER THAN TOP OF DOUBLE HANDHOLE

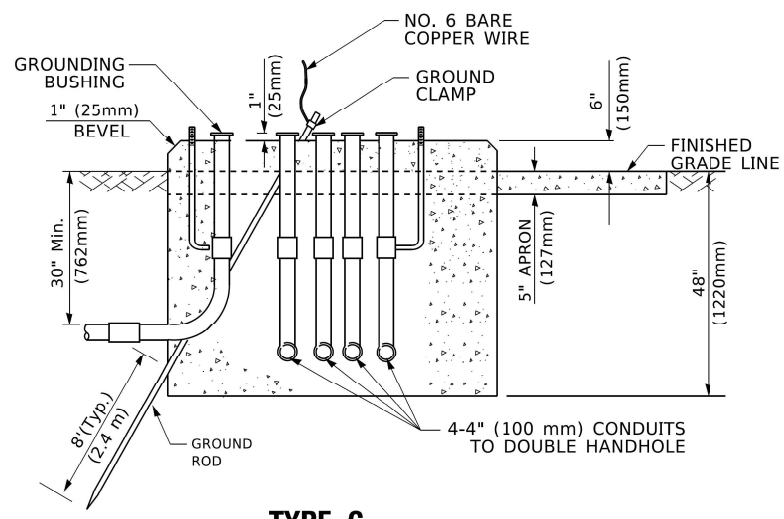

**TYPE C  
FOR GROUND MOUNTED  
SUPER P (TYPE IV) AND SUPER R (TYPE V)  
CONTROLLER CABINETS**

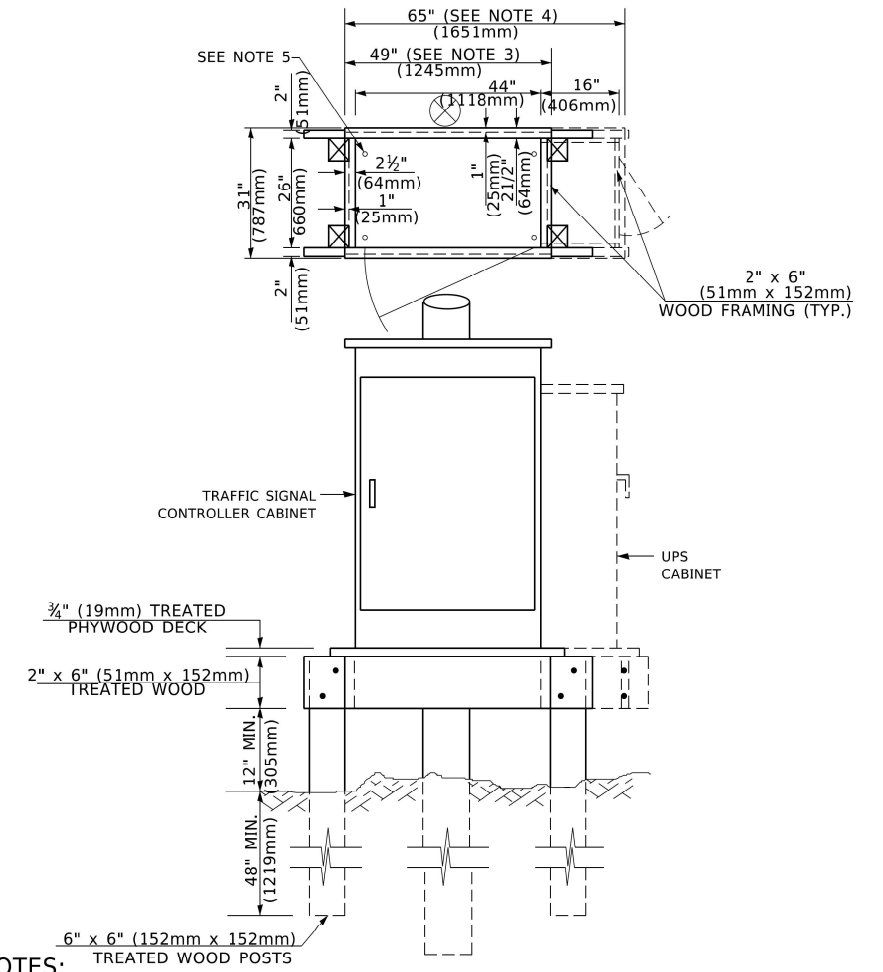

**NOTES:**

1. BASED ON CONTROLLER CABINET TYPE IV WITH BASE DIMENSIONS OF 26" x 44" (660mm x 1118mm). ADJUST PLATFORM SIZE TO FIT CABINET BASE DIMENSIONS BEING SUPPLIED.
2. BASED ON UNINTERRUPTIBLE POWER SUPPLY CABINET WITH BASE DIMENSIONS OF 16" x 25" (406mm x 635mm). ADJUST PLATFORM SIZE TO FIT CABINET BASE DIMENSIONS BEING SUPPLIED.
3. PLATFORM SIZE FOR CONTROLLER CABINET TYPE IV.
4. PLATFORM SIZE FOR CONTROLLER CABINET TYPE IV AND UNINTERRUPTIBLE POWER SUPPLY CABINET.
5. DRILLED HOLES THROUGH THE PLATFORM BASE TO MATCH THE CONTROLLER CABINET BOLT TEMPLATE. FASTEN THE CONTROLLER CABINET TO THE PLATFORM WITH CARRIAGE BOLTS, WASHERS AND NUTS.
6. FASTEN ALL SUPPORT WOOD FRAMING TO THE WOOD POSTS WITH 2 LAG SCREWS FOR EACH CONNECTION.

**TEMPORARY SIGNAL CONTROLLER  
WOOD SUPPORT PLATFORM**

CABLE SLACK LENGTH	FEET	METER
HANDHOLE	6.5	2.0
DOUBLE HANDHOLE	13.0	4.0
SIGNAL POST	2.0	0.6
MAST ARM	2.0	0.6
CONTROLLER CABINET	1.5	0.5
FIBER OPTIC AT CABINET	13.0	4.0
ELECTRIC SERVICE AT (CABINET OR SERVICE LOCATION)	1.5	0.5
GROUND CABLE (SIGNAL POST, MAST ARM, CABINET)	1.5	0.5
GROUND CABLE (BETWEEN FRAME AND COVER)	5.0	1.6

**CABLE SLACK**

VERTICAL CABLE LENGTH	FEET	METER
MAST ARM POLE (MAST ARM MOUNTED SIGNAL HEAD) (L = MAST ARM LENGTH - DISTANCE TO SIGNAL HEAD FROM END OF ARM)	20.0+L	6.0+L
BRACKET MOUNTED (MAST ARM POLE OR SIGNAL POLE)	13.0	4.0
PEDESTRIAN PUSH BUTTON	6.0	2.0
SERVICE INSTALLATION POLE MOUNT TO SERVICE DROP	13.5	4.1
SERVICE INSTALLATION POLE MOUNT TO GROUND	13.5	4.1
SERVICE INSTALLATION GROUND MOUNT	6.0	2.0
FOUNDATION (SIGNAL POST, MAST ARM POLE, CONTROLLER CABINET, SERVICE-GROUND MOUNT)	3.0	1.0

**VERTICAL CABLE LENGTH**

FOUNDATION	DEPTH
TYPE A - Signal Post	4'-0" (1.2m)
TYPE C - CONTROLLER W/ UPS	4'-0" (1.2m)
TYPE D - CONTROLLER	4'-0" (1.2m)
SERVICE INSTALLATION, GROUND MOUNT, TYPE A - SQUARE	4'-0" (1.2m)

**DEPTH OF FOUNDATION**

MAST ARM LENGTH	① FOUNDATION DEPTH	FOUNDATION DIAMETER	SPIRAL DIAMETER	QUANTITY OF REBARS	SIZE OF REBARS
Less than 30' (9.1 m)	10'-0" (3.0 m)	30" (750mm)	24" (600mm)	8	6(19)
Greater than or equal to 30' (9.1 m) and less than 40' (12.2 m)	13'-6" (4.1 m)	30" (750mm)	24" (600mm)	8	6(19)
Greater than or equal to 40' (12.2 m) and less than 50' (15.2 m)	11'-0" (3.4 m)	36" (900mm)	30" (750mm)	12	7(22)
Greater than or equal to 50' (15.2 m) and up to 55' (16.8 m)	13'-0" (4.0 m)	36" (900mm)	30" (750mm)	12	7(22)
Greater than or equal to 55' (16.8 m) and less than 65' (19.8 m)	15'-0" (4.6 m)	36" (900mm)	30" (750mm)	12	7(22)
Greater than or equal to 65' (19.8 m) and less than 75' (22.9 m)	21'-0" (6.4 m)	42" (1060mm)	36" (900mm)	16	8(25)
Greater than or equal to 75' (22.9 m)	25'-0" (7.6 m)	42" (1060mm)	36" (900mm)	16	8(25)

**NOTES:**

1. These foundation depths are for sites which have cohesive soils (clayey silt, sandy clay, etc.) along the length of the shaft, with an average Unconfined Compressive Strength (qu) > 1.0 tsf (100 kpa). This strength shall be verified by boring data prior to construction or with testing by the Engineer during foundation drilling. The Bureau of Bridges & Structures should be contacted for a revised design if other conditions are encountered.
2. Combination mast arm assemblies under 55 feet (16.8 m) shall use 36" (900 mm) diameter foundations.
3. Combination mast arm assemblies under 56 feet (16.8 m) through 75 feet (22.9 m) shall use 42" (1060 mm) diameter foundations.
4. For mast arm assemblies with dual arms refer to state standard 878001..

**DEPTH OF MAST ARM FOUNDATIONS, TYPE E**

MODEL: TS-05; FILE: NAME: C:\Engineering\Live\Projects\1003\_IDOT\_DUB\_HBR\WID - 62\43\CADD\CADD\_Sheets\CADD\163143-03-05-01\_S041.dwg

USER NAME = footemj	DESIGNED -	REVISED -
PLOT SCALE = 50.0000' / 1"	DRAWN -	REVISED -
PLOT DATE = 3/4/2019	CHECKED -	REVISED -
	DATE -	REVISED -

**STATE OF ILLINOIS  
DEPARTMENT OF TRANSPORTATION**

<b>DISTRICT ONE</b>			
<b>STANDARD TRAFFIC SIGNAL DESIGN DETAILS</b>			
SCALE: NONE	SHEET 5	OF 7 SHEETS	STA. TO STA.

F.A.P. RTE. 330	SECTION 2021-030-R5	COUNTY COOK	TOTAL SHEETS 35	SHEET NO. 21
<b>TS-05</b>		CONTRACT NO. 62N43		
ILLINOIS FED. AID PROJECT 9P76(903)				

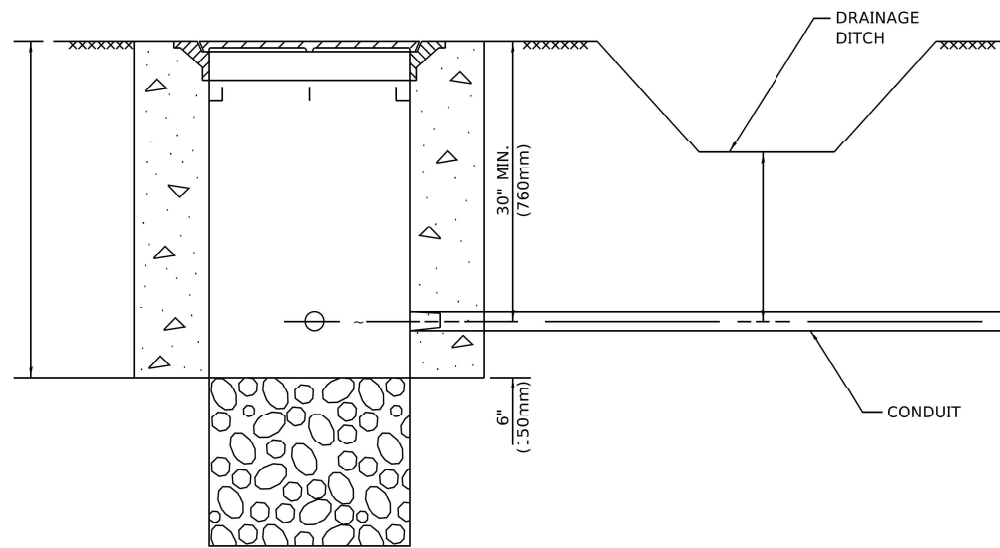

**NOTES:**

1. CONDUIT DEPTH SHALL BE A MINIMUM OF 30" (760mm) BELOW THE BOTTOM OF THE DRAINAGE DITCH OR ANY SLOPING GROUND
2. THE MINIMUM CONDUIT DEPTH APPLIES TO ALL CONDUIT PLACED UNDER ROADWAY PAVEMENT, MULTI-USE PATHS, SIDEWALKS AND SOIL SURFACES.
3. THE MINIMUM CONDUIT DEPTH APPLIES TO ALL HANDHOLES, HEAVY DUTY HANDHOLES AND DOUBLE HANDHOLES.

**HANDHOLE WITH MINIMUM CONDUIT DEPTH**  
(NOT TO SCALE)

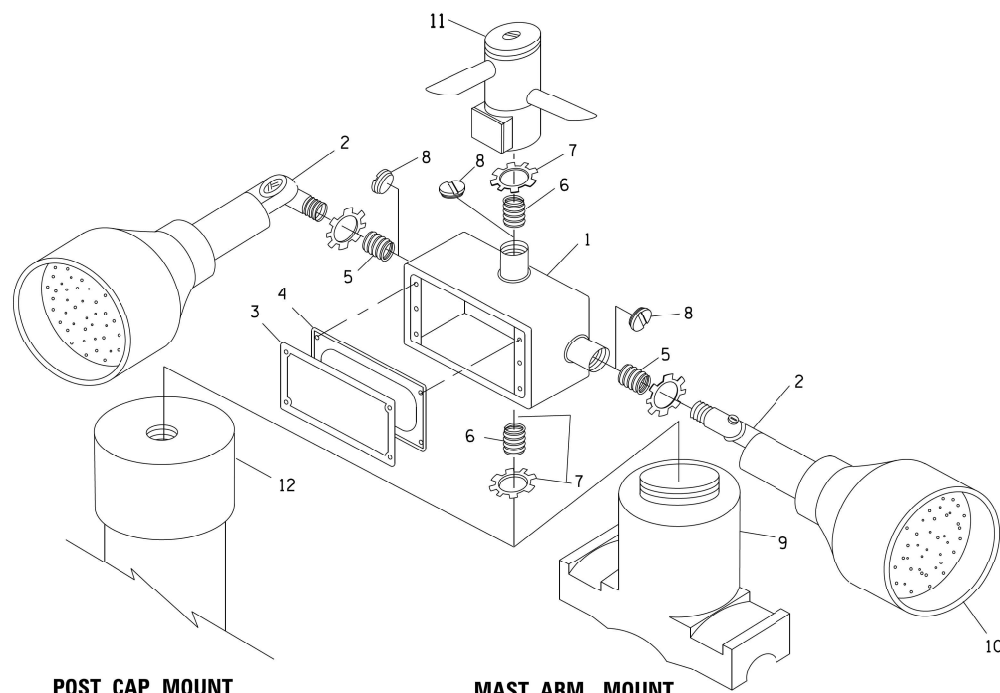

**POST CAP MOUNT**      **MAST ARM MOUNT**  
**EMERGENCY VEHICLE DETECTOR WITH CONFIRMATION BEACON MOUNTING DETAIL**

ITEM NO.	IDENTIFICATION
1	OUTLET BOX- GALV. 21 CU.IN. (0.000344 CU-M)
2	LAMP HOLDER AND COVER
3	OUTLET BOX COVER
4	RUBBER COVER GASKET
5	REDUCING BUSHING
6	3/4" (19 mm) CLOSE NIPPLE
7	3/4" (19 mm) LOCKNUT
8	3/4" (19 mm) HOLE PLUG
9	SADDLE BRACKET - GALV.
10	6 WATT PAR 38 LED FLOOD LAMP
11	DETECTOR UNIT
12	POST CAP [18 FT. (5.4 m) POST MIN.]

**NOTES:**

1. ALL ELECTRICAL ITEMS, EXCEPT ITEMS #2 AND #11 SHALL BE ALUMINUM OR GALVANIZED
2. ITEM #1- OZ/GEDNEY FSX-1-50 OR EQUIVALENT  
ITEM #2- MULBERRY CON-O-SHADE LAMP SHIELD OR EQUIVALENT  
ITEM #9- "BAND-IT" SADDLE BRACKET OR EQUIVALENT
3. WHEN POST MOUNTING IS SPECIFIED, ITEM #9 SHALL NOT BE REQUIRED. THE DETECTION UNIT SHALL BE MOUNTED DIRECTLY ON TOP OF THE CAP BY DRILLING AND TAPPING A 3/4" (19 mm) HOLE WITH PIPE THREADS. THE POST CAP SHALL EITHER BE SCREWED TO THE TOP OF THE POST OR A MINIMUM OF 3 TIGHTENING SCREWS SHALL BE REQUIRED ON EACH CAP.

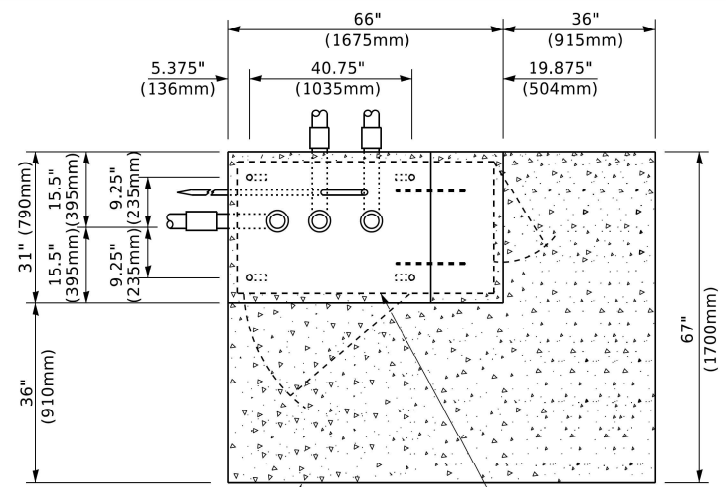

**TOP VIEW**  
(NOT TO SCALE)

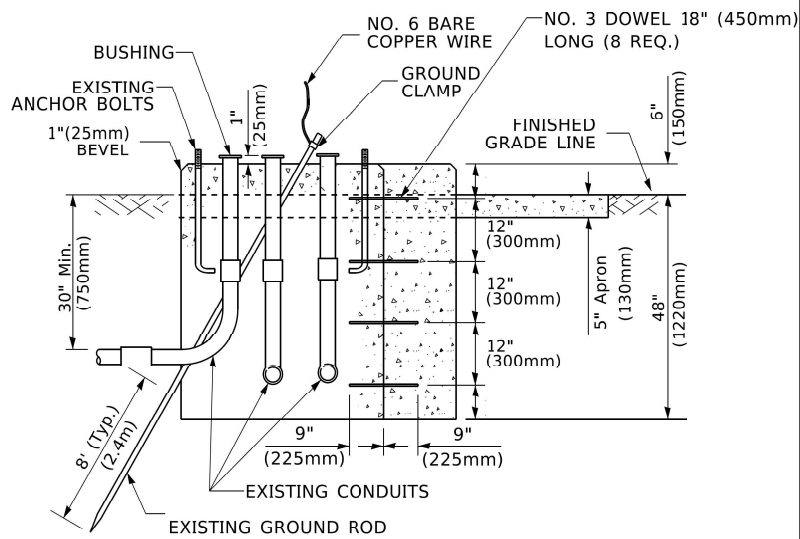

**MODIFY EXISTING TYPE "D" FOUNDATION TO TYPE "C" FOUNDATION**  
(NOT TO SCALE)

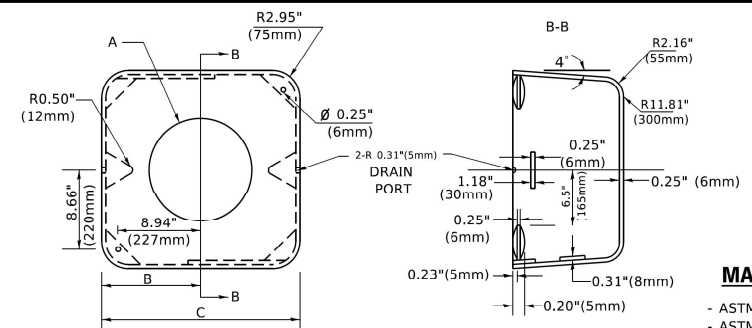

**MATERIAL**  
- ASTM A36 STEEL  
- ASTM A-123 HOT DIPPED GALVANIZED

	A	B	C	HEIGHT	WEIGHT
	VARIES	9.5"(241mm)	19"(483mm)	7" (178mm) - 12" (300mm)	53 lbs (24kg)
	VARIES	10.75"(273mm)	21.5"(546mm)	7" (178mm) - 12" (300mm)	68 lbs (31 kg)
	VARIES	13.0"(330mm)	26"(660mm)	7" (178mm) - 12" (300mm)	81 lbs (37 kg)
	VARIES	18.5"(470mm)	37"(940mm)	7" (178mm) - 12" (300mm)	126 lbs (57 kg)

**SHROUD**

**NOTES:**

1. DIMENSION "A" IS EQUAL TO THE DIAMETER OF THE MAST ARM POLE AT THE TOP OF THE SHROUD. THE SHROUD SHALL BE TIGHT TO THE MAST ARM POLE.
2. THE SUPPLIER SHALL VERIFY THE ABOVE DIMENSIONS BASED ON MAST ARM REQUIREMENTS.
3. THE HEIGHT OF THE SHROUD SHALL COVER THE ANCHOR BOLTS, NUTS AND MAST ARM POLE BASE.

**NOTE:**

SUPPORT EXISTING CABINET AND CONTROL EQUIPMENT ABOVE FOUNDATION TO KEEP TRAFFIC SIGNAL FUNCTIONING WHILE FOUNDATION MODIFICATION WORK IS PROCEEDING.

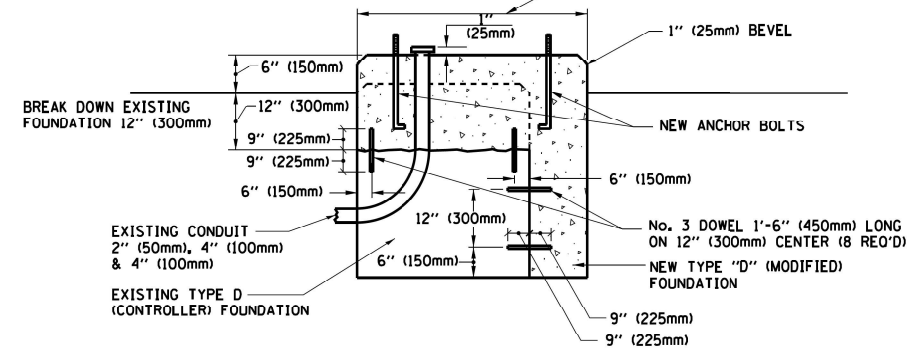

**MODIFY EXISTING TYPE "D" FOUNDATION**

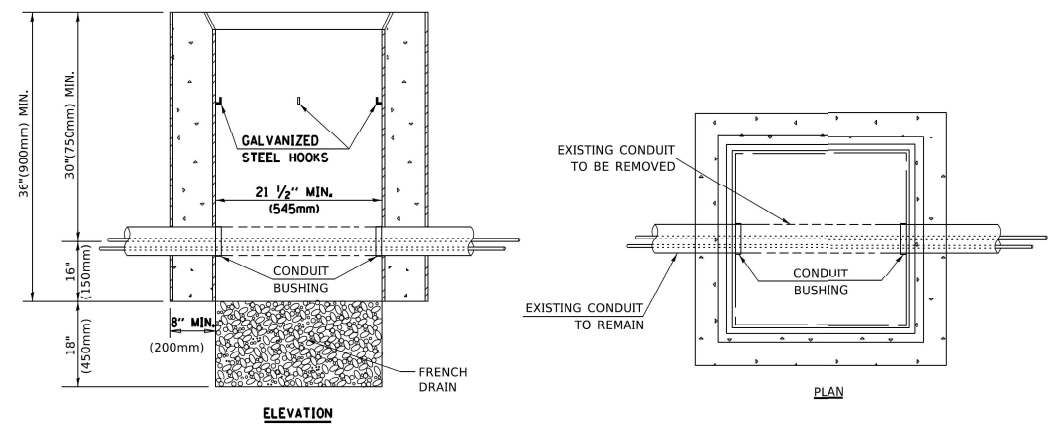

**NOTES:**

1. HANDHOLE CONSTRUCTED PER STATE STANDARD 814001.
2. REMOVAL OF THE EXISTING CONDUIT FROM THE HANDHOLE AND THE INSTALLATION OF THE CONDUIT BUSHINGS SHALL BE INCLUDED WITH THE COST OF THE HANDHOLE.

**HANDHOLE TO INTERCEPT EXISTING CONDUIT**

MODEL: TS-05.dwg FILE NAME: C:\Engineering\Live\Projects\21003\_IDOT\_DUB\_HBR\WDO\_1\_62N43\CADD\CADD\_Sheets\CADD162N43-05-05.dwg

USER NAME = footemj	DESIGNED -	REVISED -
PLOT SCALE = 50.0000' / 1"	DRAWN -	REVISED -
PLOT DATE = 3/4/2019	CHECKED -	REVISED -
	DATE -	REVISED -

**STATE OF ILLINOIS**  
**DEPARTMENT OF TRANSPORTATION**

<b>DISTRICT ONE</b>	
<b>STANDARD TRAFFIC SIGNAL DESIGN DETAILS</b>	
SCALE: NONE	SHEET 6 OF 7 SHEETS STA. TO STA.

F.A.P. RTE. 330	SECTION 2021-030-R5	COUNTY COOK	TOTAL SHEETS 35	SHEET NO. 22
<b>TS-05</b>		CONTRACT NO. 62N43		
ILLINOIS FED. AID PROJECT 9P76(903)				

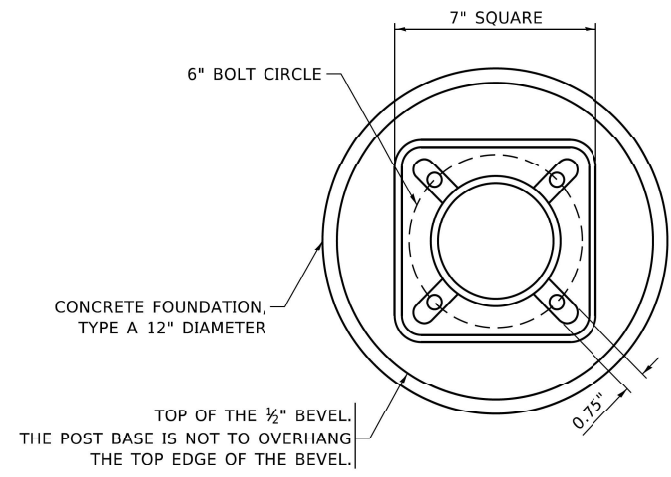

**BOLT PATTERN**

**NOTE:**  
1. IF THE PEDESTRIAN SIGNAL POST FOUNDATION IS INSTALLED WITHIN OR BEHIND A BARRIER CURB, THE TOP OF THE FOUNDATION SHALL BE INSTALLED FLUSH WITH THE TOP OF THE BARRIER CURB.

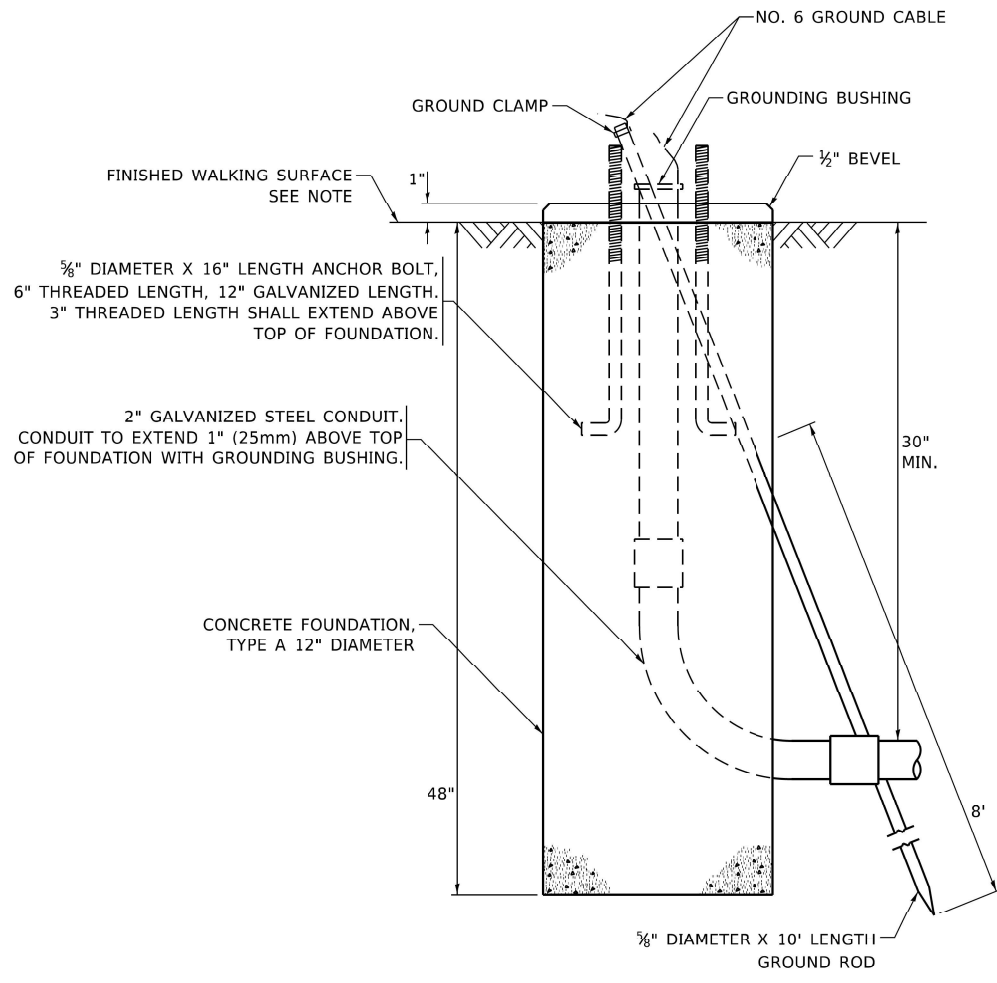

**CONCRETE FOUNDATION, TYPE A 12-INCH DIAMETER**

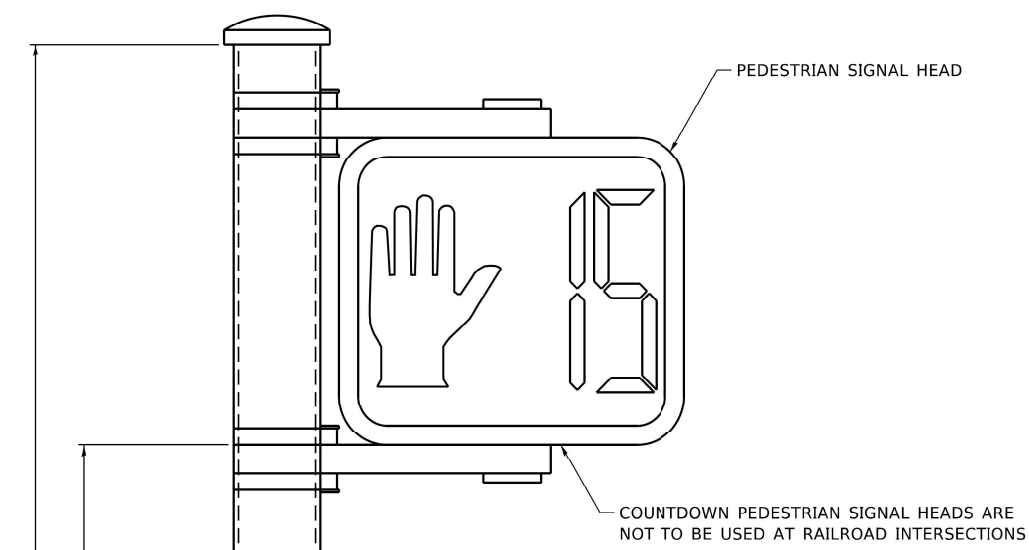

**PEDESTRIAN SIGNAL POST, 10 FT.**

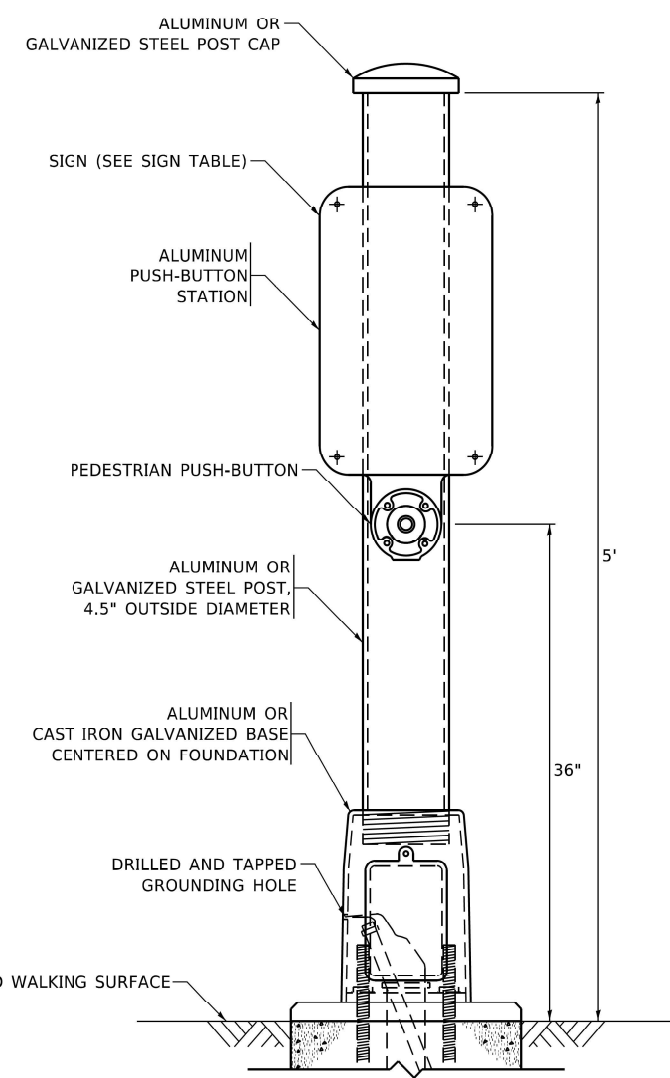

**PEDESTRIAN SIGNAL POST, 5 FT.**

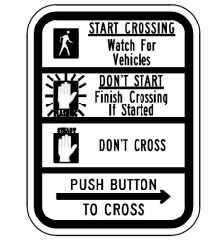

**R10-3b**

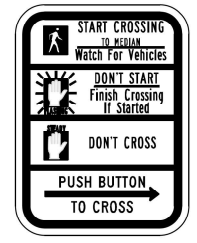

**R10-3d**

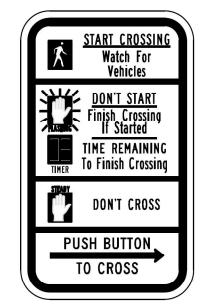

**R10-3e**

**SIGN TABLE**

SIGN	DIMENSIONS
R10-3b (RAILROAD ONLY)	9" X 12"
R10-3d (RAILROAD ONLY)	9" X 12"
R10-3e	9" X 12"

**NOTES:**  
1. THE SIGN PANELS SHALL BE TYPE AP SHEETING.  
2. THE ARROW ON SIGNS FOR PUSH-BUTTONS SERVING TWO DIRECTIONS ON THE SAME PHASE SHALL BE BI-DIRECTIONAL.  
3. THE SIGN FOR DUAL-CALL PUSH-BUTTONS SHALL HAVE NO ARROW.

MODEL: R10-01; FILE: C:\Users\gaglianobt\OneDrive\Documents\Projects\Standard Traffic Signal Design Details\Sheet 23.dwg

USER NAME = gaglianobt	DESIGNED - IP	REVISED - 10-15-2020
PLOT SCALE = 100.0000' / in.	DRAWN - IP	REVISED -
PLOT DATE = 11/23/2020	CHECKED - LP	REVISED -
	DATE - 10-15-2018	REVISED -

**STATE OF ILLINOIS  
DEPARTMENT OF TRANSPORTATION**

<b>DISTRICT ONE STANDARD TRAFFIC SIGNAL DESIGN DETAILS</b>			
SCALE: NONE	SHEET 7 OF 7 SHEETS	STA. TO STA.	

F.A.P. RTE. 330	SECTION 2021-030-R5	COUNTY COOK	TOTAL SHEETS 35	SHEET NO. 23
<b>TS-05</b>		CONTRACT NO. 62N43		
<small>ILLINOIS FED. AID PROJECT 9P76(903)</small>				

**SCHEDULE OF QUANTITIES**

ITEM DESCRIPTION	UNIT	TOTAL QTY
UNDERGROUND CONDUIT, GALVANIZED STEEL, 2" DIA	FOOT	50
MAINTENANCE OF EXISTING TRAFFIC SIGNAL INSTALLATION	EACH	1
ELECTRIC CABLE IN CONDUIT, SIGNAL NO. 14 2C	FOOT	1540
ELECTRIC CABLE IN CONDUIT, EQUIPMENT GROUNDING CONDUCTOR, NO. 6 1C	EACH	83
DRILL EXISTING HANDHOLE	EACH	5
MODIFY EXISTING CONTROLLER	EACH	1
REMOVE ELECTRIC CABLE FROM CONDUIT	FOOT	578
REMOVE EXISTING TRAFFIC SIGNAL EQUIPMENT	EACH	1
ACCESSIBLE PEDESTRIAN SIGNALS	EACH	8
PEDESTRIAN SIGNAL POST, 5 FT.	EACH	5
CONCRETE FOUNDATION, TYPE A, 12 INCH DIA.	FOOT	20
RE-OPTIMIZE TRAFFIC SIGNAL SYSTEM LEVEL 1	EACH	1

**NOTES**

THE FOLLOWING ITEMS SHALL BE REMOVED BY THE CONTRACTOR AND SHALL BE DISPOSED OF BY THEM OUTSIDE THE RIGHT-OF-WAY AT THEIR EXPENSE. THE SALVAGE VALUE OF THE REMOVED EQUIPMENT SHALL BE REFLECTED IN THE CONTRACT BID PRICE.

5 EACH PEDESTRIAN PUSH-BUTTON

ALL EXISTING PEDESTRIAN PUSH-BUTTON SHALL BE REMOVED AND PAID FOR UNDER THE PAY ITEM REMOVE EXISTING TRAFFIC SIGNAL EQUIPMENT."

CONTRACTOR SHALL PERFORM SIGNAL WORK IN SUCH A WAY AS TO MINIMIZE THE TIME THE EXISTING PEDESTRIAN EQUIPMENT IS INOPERATIONAL

CONTRACTOR SHALL CONFIRM THE FINAL LOCATION OF THE PEDESTRIAN EQUIPMENT BEFORE INSTALLATION WITH THE TRAFFIC SIGNAL AREA ENGINEER

DIMENSIONS SHOWN ARE FROM CENTER OF POST TO BACK OF CURB AND ARE APPROXIMATE AND ARE APPROXIMATE, AND PLACEMENT OF THE 5' POST SHALL BE VERIFIED WITH THE ENGINEER PRIOR TO THE START OF WORK

APS SHALL BE PLACED PARALLEL TO THE CORRESPONDING CROSSWALK

STATIONING SHOWN ON TRAFFIC SIGNAL PLAN ARE FROM RECORD DRAWINGS AND WILL NOT MATCH OTHER PLANS

WHERE TRAFFIC SIGNAL EQUIPMENT WAS REMOVED, THE EXISTING ELECTRICAL CABLE SHALL BE REMOVED FROM CONDUIT

WORK SHALL MEET REQUIREMENTS OF THE SPECIAL PROVISION, DETECTOR LOOP REPLACEMENT AND/OR INSTALLATION (ROADWAY GRINDING, RESURFACING & PATCHING OPERATIONS).

THIS PLAN IS FOR THE SOLE PURPOSE OF DETECTOR LOOP REPLACEMENT AND APS INSTALLATION

CONTRACTOR SHALL FIELD VERIFY ALL EXISTING TRAFFIC SIGNAL EQUIPMENT PRIOR TO ORDERING MATERIALS AND STARTING ANY WORK

US 12/20/45 (MANNHEIM)

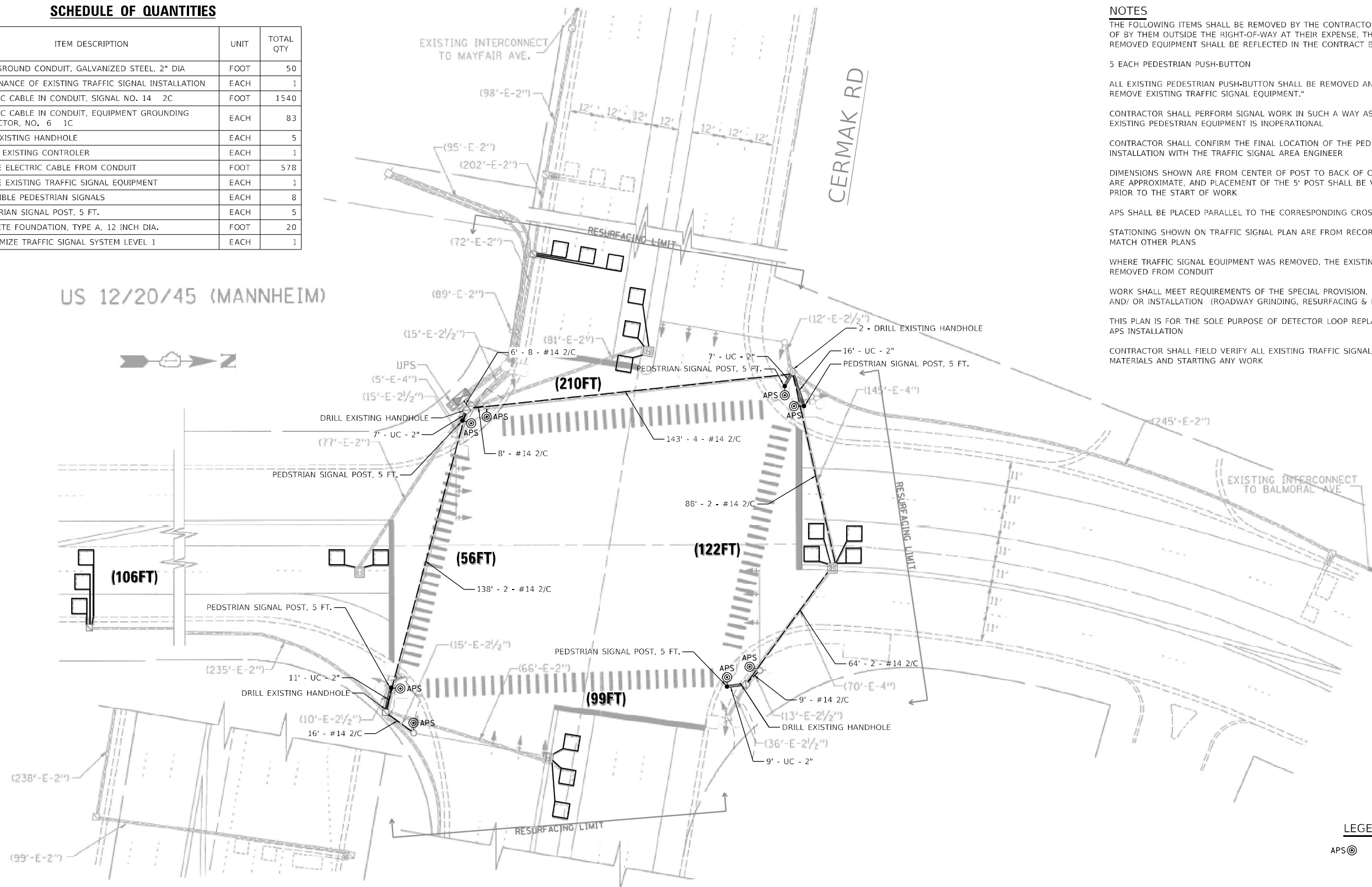

**LEGEND**

APS⊙ APS PUSH-BUTTON

**REPLACE ALL DETECTOR LOOPS AS SHOWN (WITHIN THE RESURFACING LIMITS)**

CODE	ITEM	QUANTITY	UNIT
88600600	DETECTOR LOOP REPLACEMENT	593	FOOT

TS#1050

STATE OF ILLINOIS  
DEPARTMENT OF TRANSPORTATION

DETECTOR LOOP REPLACEMENT PLAN  
US 12 /20 /45 (LAGRANGE RD.) AT CERMAK RD.

F.A. RTE.	SECTION	COUNTY	TOTAL SHEETS	SHEET NO.
330	2021-030-R5	COOK	35	24
CONTRACT NO. 62N43				
ILLINOIS FED. AID PROJECT				
CONTRACT NO. 62N43				
ILLINOIS FED. AID PROJECT 9P76(903)				

STATE OF ILLINOIS  
DEPARTMENT OF TRANSPORTATION

ACCESSIBLE PEDESTRIAN SIGNAL INSTALLATION PLAN  
US 12 /20 /45 OVERLAY AND ADA RAMP IMPROVEMENTS

USER NAME	DESIGNED	REVISIONS
mezag	Steven M. Nguyen	-
	Gonzalo Meza	-
PLOT SCALE = 40,0000' / in.	Steven M. Nguyen	-
PLOT DATE = 6/2/2021	06/02/2021	-
mezakufahy	JLS	-
	JLS	-
PLOT SCALE = 46,2000' / in.	JJD	-
PLOT DATE = 3/23/2022	03/18/2021	-



MODEL: Projects / 1000  
FILE NAME: C:\Engineering\Live\Projects\1003\_IDOT\_DUB\_HBR\WID - 62N43\CADD\CADD\_Sheets\C1\MD1651\13-20-APS\_and\_Detector\_Loops.dwg



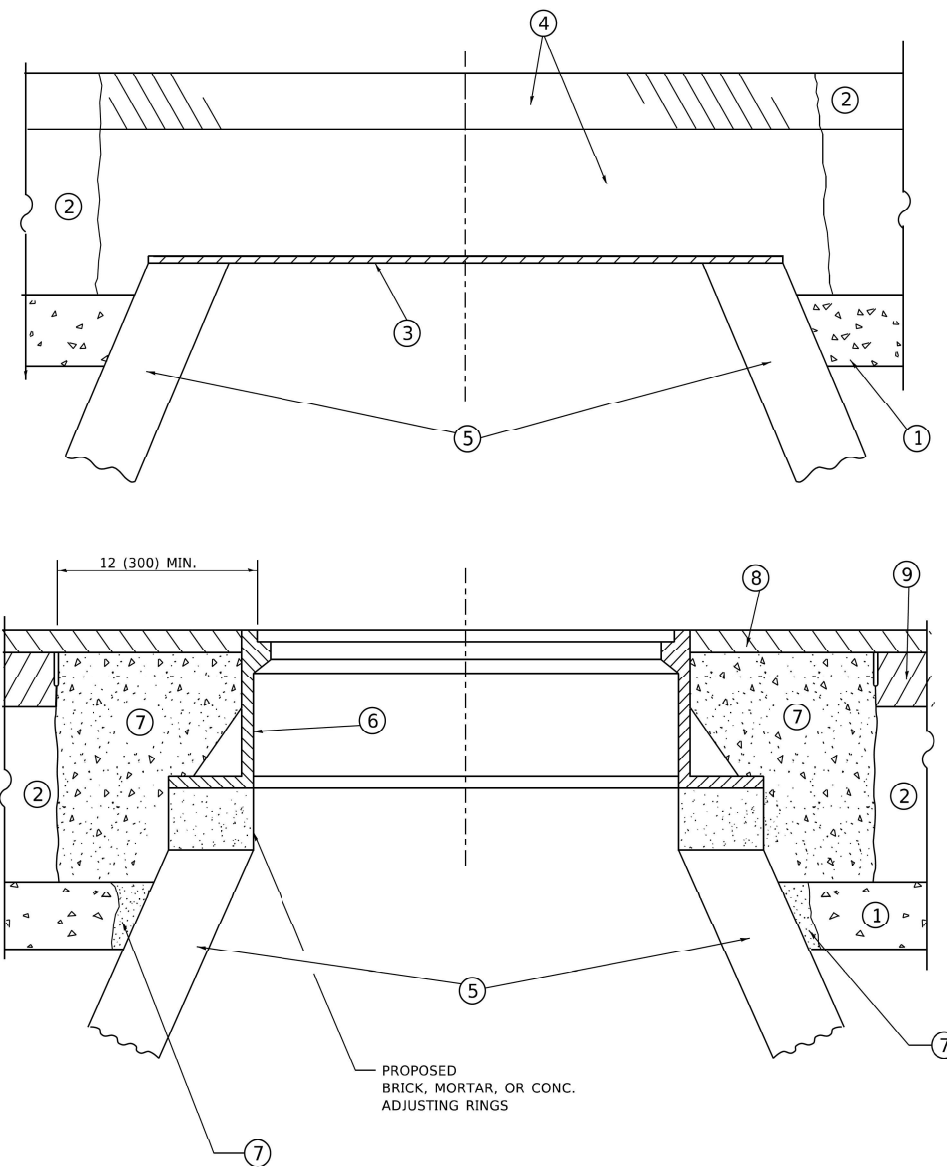

**DETAILS FOR FRAMES AND LIDS ADJUSTMENT  
WITH MILLING**

**NOTES**

1. EXISTING BROKEN FRAMES AND LIDS SHALL BE REMOVED AND DISPOSED OF BY THE CONTRACTOR AND SHALL BE REPLACED AS DIRECTED BY THE ENGINEER. REPLACEMENT FRAMES AND LIDS WILL BE PAID FOR IN ACCORDANCE WITH ARTICLE 109.04 OF THE STANDARD SPECIFICATIONS UNLESS A SEPARATE PAY ITEM HAS BEEN PROVIDED.
2. IF THE EXISTING LIDS ARE OPEN, THE FRAME WILL BE ADJUSTED TO THE ELEVATION OF THE MILLED PAVEMENT SURFACE PRIOR TO THE MILLING OPERATION. THE FRAME WILL NOT BE REMOVED AND COVERED BY THE METAL PLATE.
3. CITY OF CHICAGO CASTINGS ARE THE PROPERTY OF THE CITY AND THE CONTRACTOR SHALL NOTIFY THE CITY FOR REMOVAL AND DISPOSITION OF THE CASTINGS.
4. THE METAL PLATE USED TO COVER THE STRUCTURE SHALL REMAIN THE PROPERTY OF THE CONTRACTOR.

**CONSTRUCTION PROCEDURES**

**STAGE 1 (BEFORE PAVEMENT MILLING)**

- A) REMOVE A MINIMUM OF 12 (300) OF THE PAVEMENT FROM AROUND THE STRUCTURE.
- B) REMOVE THE EXISTING FRAME AND LID FROM THE STRUCTURE.
- C) COVER THE STRUCTURE OPENING WITH A 36 (900) DIAMETER METAL PLATE.
- D) BACKFILL WITH CRUSHED STONE AND HMA SURFACE MIX APPROVED BY THE ENGINEER. (MIN. 1 1/2 (40) HMA TO REMAIN AFTER MILLING).

**STAGE 2 (AFTER PAVEMENT MILLING)**

- A) REMOVE THE HMA SURFACE MIX AND CRUSHED STONE.
- B) INSTALL THE FRAME AND LID; ADJUST THE FRAME TO ITS FINAL SURFACE ELEVATION.
- C) THE SURROUNDING SPACE SHALL BE FILLED WITH CLASS\*PP-1 CONCRETE TO THE ELEVATION OF THE SURFACE OF THE EXISTING BASE COURSE OR THE BINDER COURSE.

\* UNLESS OTHERWISE SPECIFIED IN THE PLANS.

THE PROCEDURE EXPLAINED ABOVE SHALL CONFORM TO THE APPLICABLE PORTIONS OF SECTIONS 353, 406, 602, AND 603 OF THE STANDARD SPECIFICATIONS EXCEPT THAT "THE CONTRACTOR SHALL ADJUST THE STRUCTURES TO THE FINISHED PAVEMENT ELEVATION NO MORE THAN 5 CALENDAR DAYS PRIOR TO PLACEMENT OF THE FINAL LIFT OF SURFACE UNLESS APPROVED BY THE ENGINEER."

**LEGEND**

- |  |                               |
|--|-------------------------------|
| ① SUB-BASE GRANULAR MATERIAL                 | ⑥ FRAME AND LID (SEE NOTES)   |
| ② EXISTING PAVEMENT                          | ⑦ CLASS*PP-1 CONCRETE         |
| ③ 36 (900) DIAMETER METAL PLATE              | ⑧ PROPOSED HMA SURFACE COURSE |
| ④ PROPOSED CRUSHED STONE AND HMA SURFACE MIX | ⑨ PROPOSED HMA BINDER COURSE  |
| ⑤ EXISTING STRUCTURE                         |                               |

**LOCATION OF STRUCTURES**

THE CONTRACTOR WILL BE REQUIRED TO KEEP A RECORD OF THE LOCATIONS OF THE BURIED STRUCTURES ACCORDING TO THE STATION AND DISTANCE LEFT OR RIGHT OF THE CENTERLINE OF PAVEMENT. UPON COMPLETION OF THE WORK, THE CONTRACTOR WILL DELIVER THE RECORD TO THE ENGINEER.

**BASIS OF PAYMENT**

1. REMOVING FRAMES AND LIDS ON DRAINAGE AND UTILITY STRUCTURES IN THE PAVEMENT PRIOR TO MILLING, AND ADJUSTING TO FINAL GRADE PRIOR TO PLACING THE SURFACE COURSE, WILL BE PAID FOR AT THE CONTRACT UNIT PRICE EACH FOR "FRAMES AND LIDS TO BE ADJUSTED (SPECIAL)."
2. THIS WORK WILL NOT BE PAID FOR WHEN DRAINAGE AND UTILITY STRUCTURES ARE SPECIFIED FOR PAYMENT AS STRUCTURE RECONSTRUCTION.
3. NEW FRAMES AND LIDS, WHEN SPECIFIED, WILL BE PAID FOR SEPARATELY.
4. WHEN STRUCTURES ARE TO BE ADJUSTED OR RECONSTRUCTED, THE LOWERING AND RAISING OF THE FRAMES AND LIDS WILL NOT BE PAID FOR SEPARATELY BUT WILL BE INCLUDED IN THE COST OF THE CORRESPONDING PAY ITEM.

ALL DIMENSIONS ARE IN INCHES (MILLIMETERS) UNLESS OTHERWISE SHOWN

MODEL: BD-08  
FILE NAME: Co\_Engineering\1\live\Project\1003\_IDOT\_DUB\_HBR\W0\_1\_62\143\CADD\CADD\_Sheets\CURB\162\143-03-08-08\_Std.dgn

USER NAME = demanchelt	DESIGNED - R. SHAH	REVISED - R. BORO 01-01-07
	DRAWN -	REVISED - R. BORO 03-09-11
PLOT SCALE = 100.0000' / in.	CHECKED -	REVISED - R. BORO 12-06-11
PLOT DATE = 2/2/2022	DATE - 10-25-94	REVISED - K. SMITH 02-01-22

**STATE OF ILLINOIS  
DEPARTMENT OF TRANSPORTATION**

**DETAILS FOR  
FRAMES AND LIDS ADJUSTMENT WITH MILLING**

SCALE: NONE SHEET 1 OF 1 SHEETS STA. TO STA.

F.A.P. RTE. 330	SECTION 2021-030-R5	COUNTY COOK	TOTAL SHEETS 35	SHEET NO. 25
BD600-03 (BD-08)		CONTRACT NO. 62N43		
ILLINOIS FED. AID PROJECT 9P76(903)				

**METHOD OF MEASUREMENT**

REFER TO SECTION 442 OF THE STANDARD SPECIFICATIONS FOR ROAD AND BRIDGE CONSTRUCTION AND THE RECURRING SPECIAL PROVISION "PATCHING WITH HOT-MIX ASPHALT OVERLAY REMOVAL."

**BASIS OF PAYMENT**

1. REFER TO SECTION 442 OF THE STANDARD SPECIFICATIONS FOR ROAD AND BRIDGE CONSTRUCTION AND THE RECURRING SPECIAL PROVISION "PATCHING WITH HOT-MIX ASPHALT OVERLAY REMOVAL."
2. SAW CUT/SCORING OF EXISTING HMA OVERLAY IS INCLUDED IN THE COST OF PAVEMENT PATCHING.
3. SAW CUT/SCORING OF EXISTING PAVEMENT IS INCLUDED IN THE COST OF PAVEMENT PATCHING.

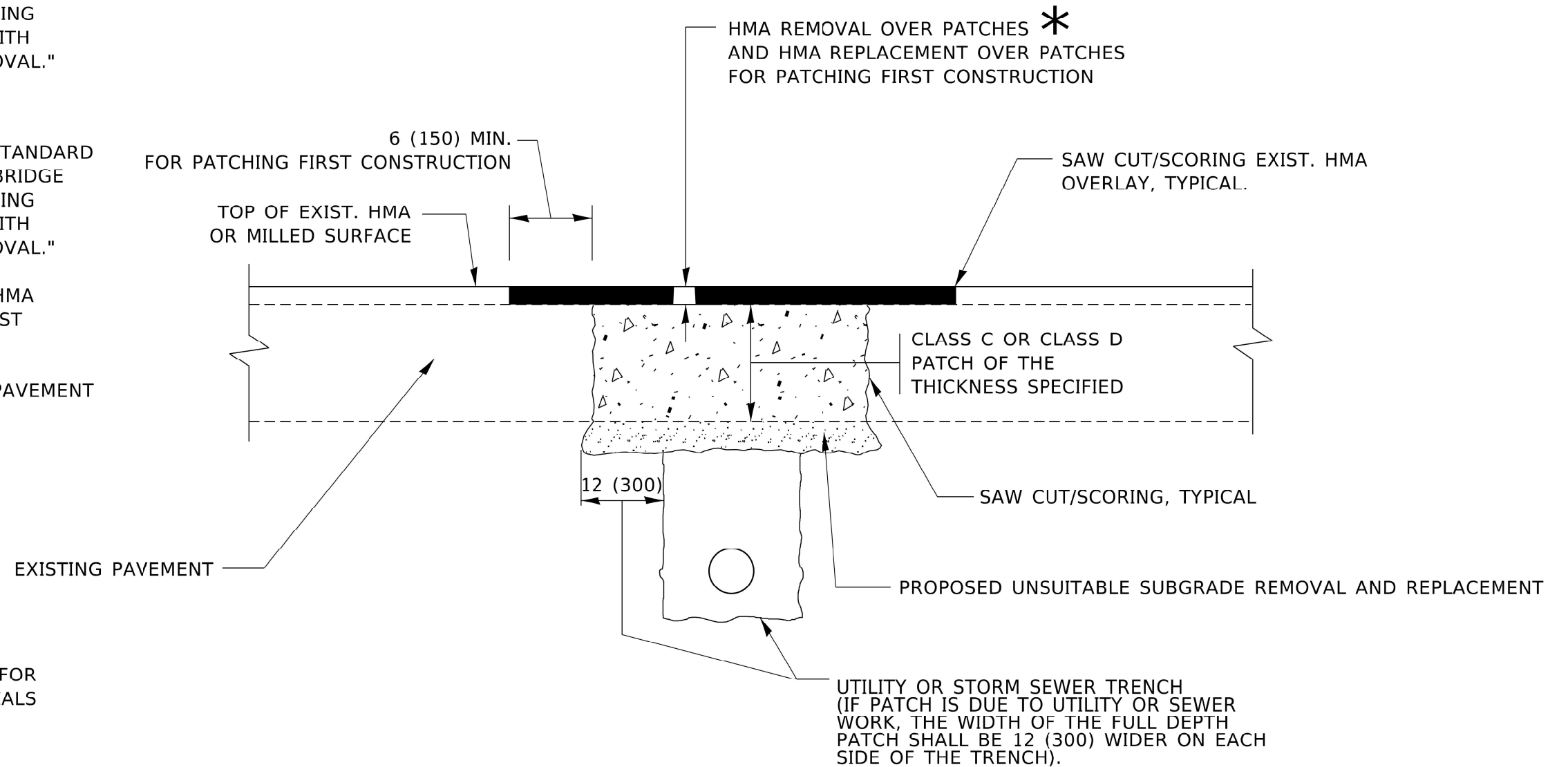

\* SEE TYPICAL SECTIONS FOR THICKNESS AND MATERIALS

**SEQUENCE OF CONSTRUCTION (PATCHING FIRST)**

1. REMOVE THE EXISTING HMA MATERIAL OVER THE AREA TO BE PATCHED.
2. REMOVE AND REPLACE WITH CLASS C OR D PATCH.
3. REPLACE HMA MATERIAL OVER THE AREA TO BE PATCHED.

**SEQUENCE OF CONSTRUCTION (MILLING FIRST)**

1. MILL HMA FIRST IF THERE IS AT LEAST 4½ INCHES OR MORE OF HMA MATERIAL ON TOP OF THE EXISTING PAVEMENT OR IF THE PAVEMENT IS FULL DEPTH HMA. A MINIMUM OF 2 INCHES OF HMA MATERIAL SHALL BE IN PLACE AFTER MILLING.
2. REMOVE AND REPLACE WITH FULL DEPTH CLASS D PATCHES TO TOP OF MILLED SURFACE.

ALL DIMENSIONS ARE IN INCHES (MILLIMETERS) UNLESS OTHERWISE SHOWN.

MODEL: B06071; FILE: C:\MIS\B06071\B06071.dwg; PLOT DATE: 2/2/2022; PLOT SCALE: 100.0000 "/>

USER NAME = demanchelt	DESIGNED - R. SHAH	REVISED - R. BORO 01-01-07
	DRAWN -	REVISED - R. BORO 09-04-07
PLOT SCALE = 100.0000 " / in.	CHECKED -	REVISED - K. ENG 10-27-08
PLOT DATE = 2/2/2022	DATE - 10-25-94	REVISED - K. SMITH 02-01-22

STATE OF ILLINOIS  
DEPARTMENT OF TRANSPORTATION

PAVEMENT PATCHING FOR  
HMA SURFACED PAVEMENT

SCALE: NONE SHEET 1 OF 1 SHEETS STA. TO STA.

F.A.P. RTE.	SECTION	COUNTY	TOTAL SHEETS	SHEET NO.
330	2021-030-R5	COOK	35	26
BD400-04 (BD-22)		CONTRACT NO. 62N43		
ILLINOIS FED. AID PROJECT 9P76(903)				

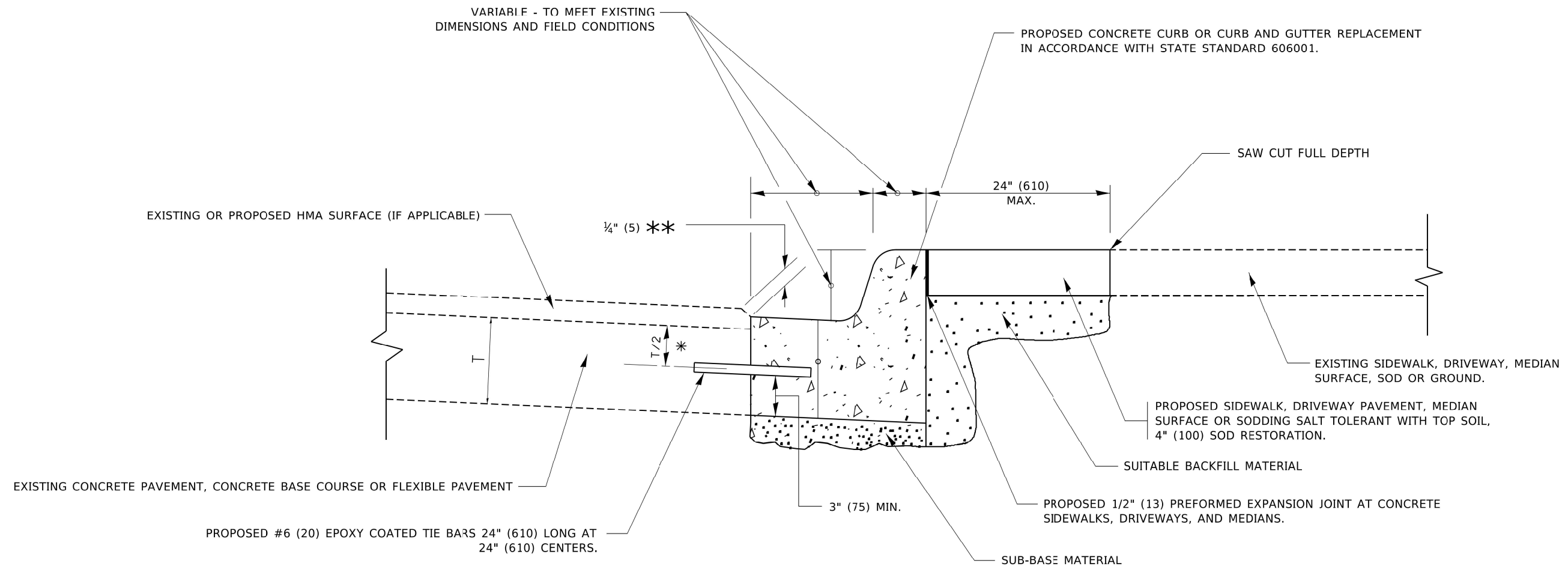

- \* 3" (75) MINIMUM FROM TOP AND BOTTOM OF THE CONCRETE PAVEMENT OR BASE COURSE.
- \*\* IF THE FINAL SURFACE OF THE PAVEMENT IS CONCRETE, THE GUTTER IS TO BE FLUSH WITH THE PAVEMENT.

# CURB OR CURB AND GUTTER REMOVAL AND REPLACEMENT

ALL DIMENSIONS ARE IN INCHES (MILLIMETERS) UNLESS OTHERWISE SHOWN.

MODEL: R06011; FILE: C:\Users\Public\Documents\AutoCAD\2019\Projects\2019-03-11-19\2019-03-11-19.dwg

USER NAME = footemj	DESIGNED - A. HOUSEH	REVISED - A. ABBAS 03-21-97
PLOT SCALE = 50.0000' / in.	DRAWN -	REVISED - M. GOMEZ 01-22-01
PLOT DATE = 7/11/2019	CHECKED -	REVISED - R. BORO 12-15-09
	DATE - 03-11-94	REVISED - K. SMITH 07-11-19

**STATE OF ILLINOIS  
DEPARTMENT OF TRANSPORTATION**

<b>CURB OR CURB AND GUTTER REMOVAL AND REPLACEMENT</b>			
SCALE: NONE	SHEET 1	OF 1 SHEETS	STA. TO STA.

F.A.P. RTE. 330	SECTION 2021-030-R5	COUNTY COOK	TOTAL SHEETS 35	SHEET NO. 27
<b>BD600-06 (BD-24)</b>		CONTRACT NO. 62N43		
ILLINOIS FED. AID PROJECT 9P76(903)				

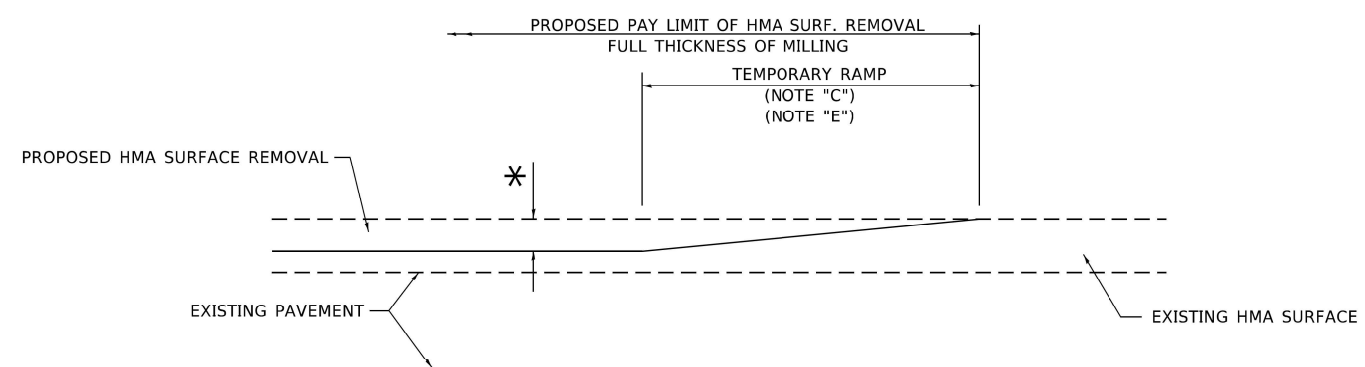

**MILLED TEMPORARY RAMP**

(FOR BUTT JOINT AND HMA TAPER SEE DETAIL BELOW)

**OPTION 1**

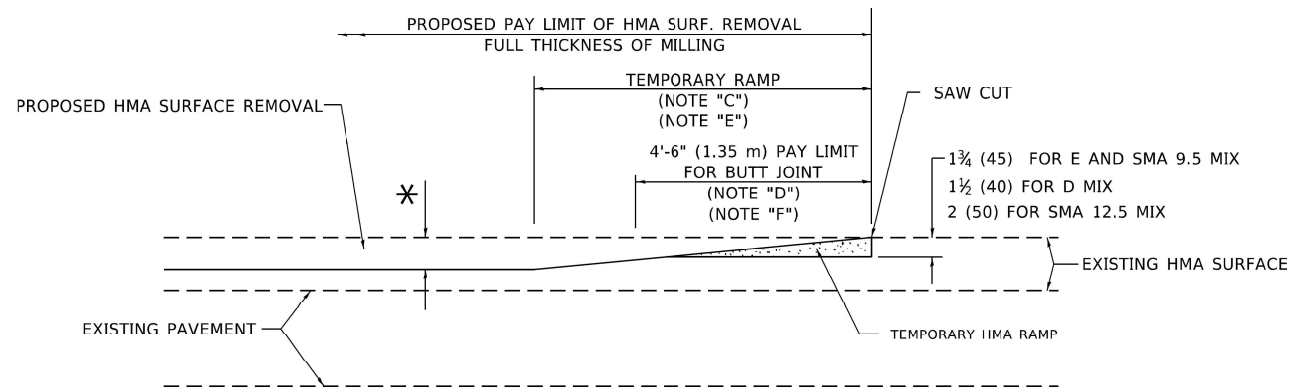

**HMA CONSTRUCTED TEMPORARY RAMP**

(FOR BUTT JOINT AND HMA TAPER SEE DETAIL BELOW)

**OPTION 2**

**TYPICAL TEMPORARY RAMP**

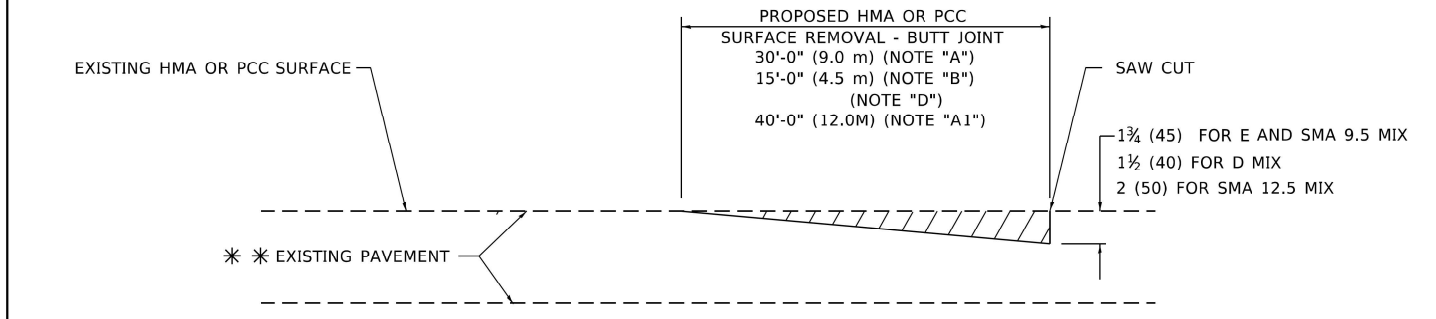

**BUTT JOINT DETAIL**

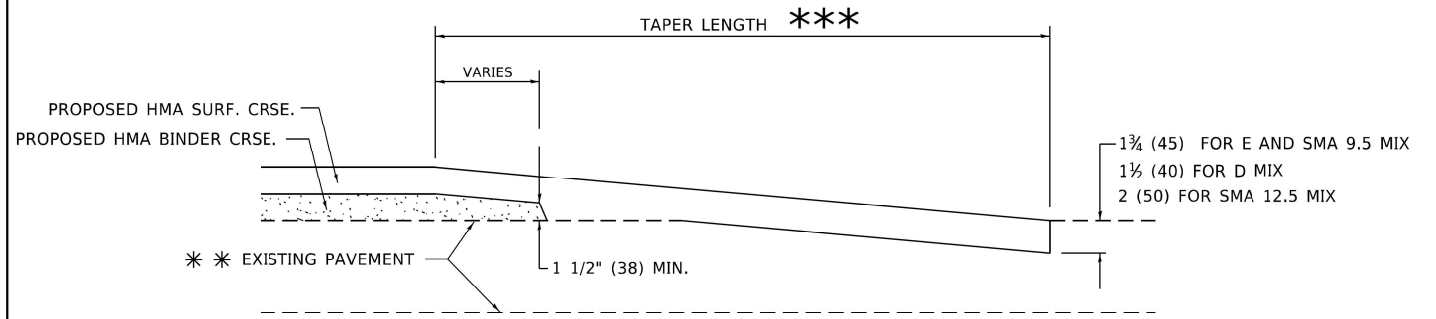

**HMA TAPER DETAIL**

**TYPICAL BUTT JOINT AND HMA TAPER FOR RESURFACING ONLY**

\*\*\* PC CONCRETE, HMA OR HMA RESURFACED PAVEMENT.

**GENERAL NOTES**

- A. MAINLINE ARTERIAL ROADWAYS AND MAJOR SIDE ROADS.
- A1. INTERSTATES
- B. MINOR SIDE ROADS.
- C. THE TEMP. RAMP SHALL BE CONSTRUCTED IMMEDIATELY UPON REMOVAL OF THE EXISTING HMA SURFACE.
- D. THE BUTT JOINT SHALL BE CONSTRUCTED IMMEDIATELY PRIOR TO PLACING THE PROPOSED HMA COURSES.
- E. TAPER THE TEMP. RAMP AT A RATE OF 3' - 4" (1.02m) PER 1 INCH (25 mm) OF MILLING THICKNESS.  
\* SEE TYPICAL SECTIONS FOR MILLING THICKNESS.
- F. SEE ARTICLE 406.08 AND 406.14 OF THE STANDARD SPECIFICATIONS FOR "HMA AND/OR PCC SURFACE REMOVAL, BUTT JOINT".  
\*\*\* 20'-0" (6.1 m) PER 1 (25) RESURFACING (NOTE "A")  
10'-0" (3.0 m) PER 1 (25) RESURFACING (NOTE "B")

**BASIS OF PAYMENT**

- 1. THE BUTT JOINT WILL BE PAID FOR AT THE CONTRACT UNIT PRICE PER SQUARE YARD (SQUARE METER) FOR "HOT-MIX ASPHALT SURFACE REMOVAL - BUTT JOINT" OR FOR "PORTLAND CEMENT CONCRETE SURFACE REMOVAL- BUTT JOINT".
- 2. THE TEMPORARY RAMP AND SAW CUT SHALL BE INCLUDED IN THE UNIT COST FOR HMA OR PCC SURFACE REMOVAL-BUTT JOINT.

ALL DIMENSIONS ARE IN INCHES (MILLIMETERS) UNLESS OTHERWISE SHOWN.

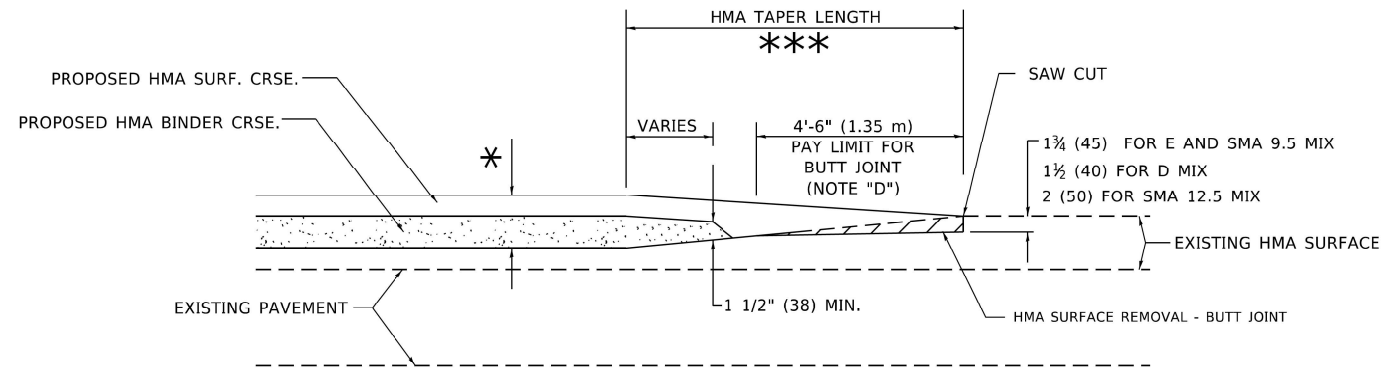

**BUTT JOINT AND HMA TAPER**

**TYPICAL BUTT JOINT AND HMA TAPER FOR MILLING AND RESURFACING**

MODEL: BD-32  
FILE NAME: Co\_Engineering\Live\Projects\21003\_IDOT\_DUB\_HBR\WID - 62N43\CADD\CADD\_Sheets\CADD162N43-04-08\_Std.dwg

USER NAME = demanchelt	DESIGNED - M. DE YONG	REVISED - A. ABBAS 03-21-97
	DRAWN -	REVISED - M. GOMEZ 04-06-01
PLOT SCALE = 100.0000' / in.	CHECKED -	REVISED - R. BORO 01-01-07
PLOT DATE = 2/2/2022	DATE - 06-13-90	REVISED - K. SMITH 02-01-22

STATE OF ILLINOIS  
DEPARTMENT OF TRANSPORTATION

<b>BUTT JOINT AND HMA TAPER DETAILS</b>			
SCALE: NONE	SHEET 1	OF 1 SHEETS	STA. TO STA.

F.A.P. RTE. 330	SECTION 2021-030-R5	COUNTY COOK	TOTAL SHEETS 35	SHEET NO. 28
<b>BD400-05 BD-32</b>		CONTRACT NO. 62N43		
ILLINOIS FED. AID PROJECT 9P76(903)				

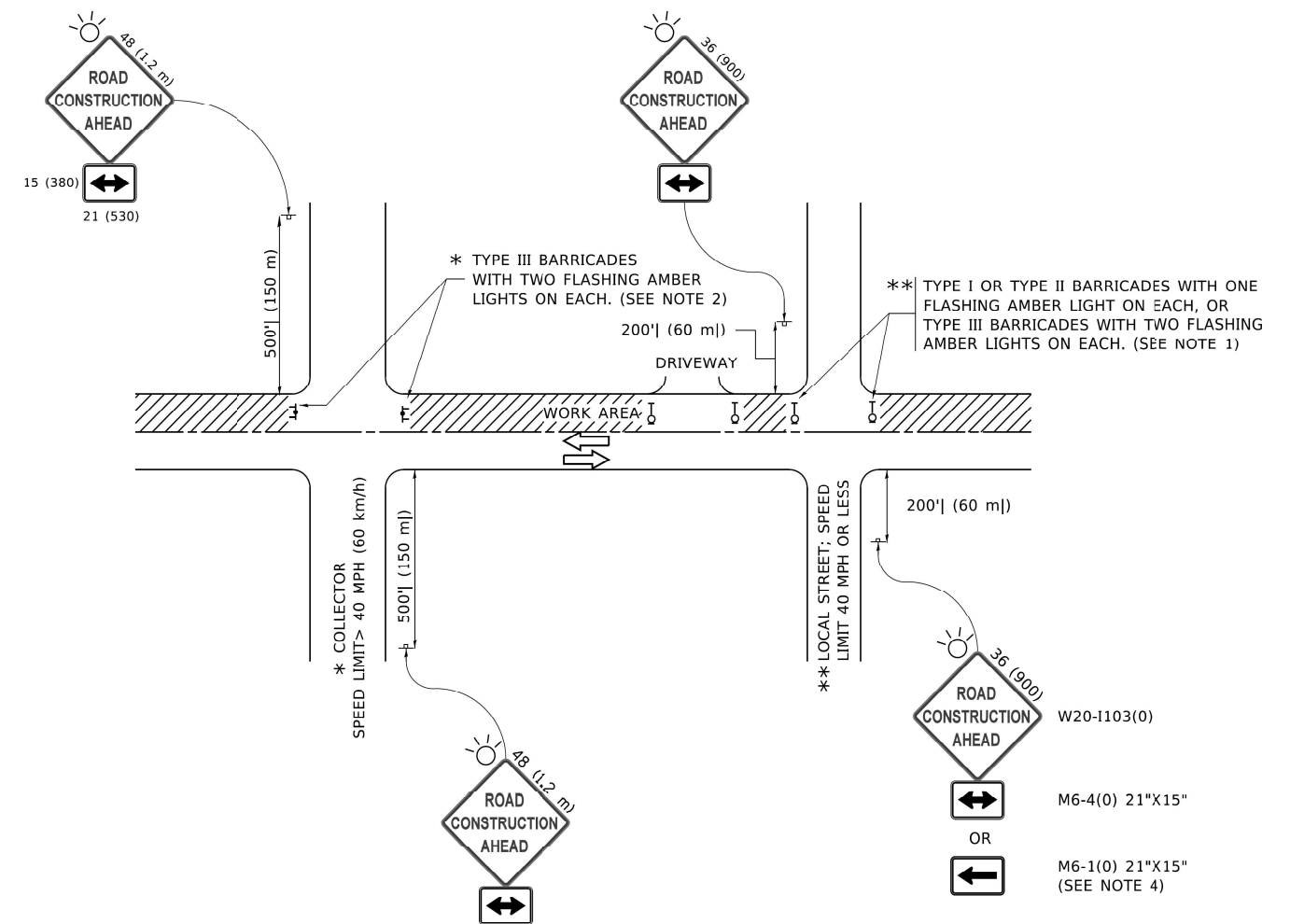

**NOTES:**

- SIDE ROAD WITH A SPEED LIMIT OF 40 MPH (60 km/h) OR LESS AS SHOWN ON THE DRAWING AND AS DIRECTED BY THE ENGINEER:
  - ONE "ROAD CONSTRUCTION AHEAD" SIGN 36 x 36 (900x900) WITH A FLASHER MOUNTED ON IT APPROXIMATELY 200' (60 m) IN ADVANCE OF THE MAIN ROUTE.
  - THE CLOSED PORTION OF THE MAIN ROUTE SHALL BE PROTECTED BY BLOCKING WITH TYPE I, TYPE II OR TYPE III BARRICADES, 1/3 OF THE CROSS SECTION OF THE CLOSED PORTION.
- SIDE ROAD WITH A SPEED LIMIT GREATER THAN 40 MPH (60 km/h) AS SHOWN ON THE DRAWING AND AS DIRECTED BY THE ENGINEER.
  - ONE "ROAD CONSTRUCTION AHEAD" SIGN 48 x 48 (1.2 m x 1.2 m) WITH A FLASHER MOUNTED ON IT APPROXIMATELY 500' (150 m) IN ADVANCE OF THE MAIN ROUTE.
  - THE CLOSED PORTION OF THE MAIN ROUTE SHALL BE PROTECTED BY BLOCKING WITH TYPE III BARRICADES, 1/2 OF THE CROSS SECTION OF THE CLOSED PORTION.
- CONES MAY BE SUBSTITUTED FOR BARRICADES OR DRUMS AT HALF THE SPACING DURING DAY OPERATIONS. CONES SHALL BE A MINIMUM OF 28 (710) IN HEIGHT.
- WHEN THE SIDE ROAD LIES BETWEEN THE BEGINNING OF THE MAINLINE AND THE WORK ZONE, A SINGLE HEADED ARROW (M6-1) SHALL BE USED IN LIEU OF THE DOUBLE HEADED ARROW (M6-4).
- WHEN WORK IS BEING PERFORMED ON A SIDE ROAD OR DRIVEWAY, FOLLOW THE APPLICABLE STANDARD(S). THE DIRECTIONAL ARROW (M6-1 OR M6-4) SHALL BE COVERED OR REMOVED WHEN NO LONGER CONSISTENT WITH THE TRAFFIC CONTROL SET-UP.
- ADVANCE WARNING SIGNS ARE TO BE OMITTED ON DRIVEWAYS UNLESS OTHERWISE SPECIFIED IN THE PLANS OR BY THE ENGINEER.
- THE TRAFFIC CONTROL AND PROTECTION FOR SIDE ROADS, INTERSECTIONS, AND DRIVEWAYS SHALL BE INCLUDED IN THE COST OF SPECIFIED TRAFFIC CONTROL STANDARDS OR ITEMS.

All dimensions are in inches (millimeters) unless otherwise shown.

MODEL: TC-10  
FILE NAME: C:\Engineering\Live\Projects\21003\_IDOT\_DUB\_HDR\WID\_1 - 62N43\CADD\CADD\_Sheets\CADD\_Sheet10.dwg  
DATE: 3/4/2019

USER NAME = footemj	DESIGNED - L.H.A.	REVISED - A. HOUSEH 10-15-96
PLOT SCALE = 50.0000' / 1"	CHECKED -	REVISED - T. RAMMACHER 01-06-00
PLOT DATE = 3/4/2019	DATE - 06-89	REVISED - A. SCHUETZE 07-01-13
		REVISED - A. SCHUETZE 09-15-16

**STATE OF ILLINOIS  
DEPARTMENT OF TRANSPORTATION**

**TRAFFIC CONTROL AND PROTECTION FOR  
SIDE ROADS, INTERSECTIONS, AND DRIVEWAYS**

SCALE: NONE SHEET 1 OF 1 SHEETS STA. TO STA.

F.A.P. RTE.	SECTION	COUNTY	TOTAL SHEETS	SHEET NO.
330	2021-030-R5	COOK	35	29
<b>TC-10</b>		CONTRACT NO. 62N43		
ILLINOIS FED. AID PROJECT 9P76(903)				

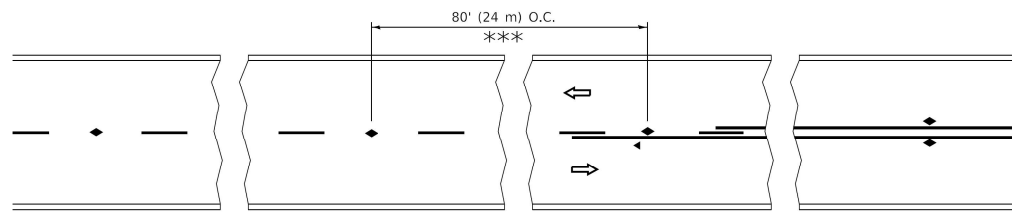

\*\*\* REDUCE TO 40' (12 m) O.C. ON CURVES WITH POSTED OR ADVISORY SPEED 45 M.P.H. (70 km/h) OR LESS.

**TWO-LANE/TWO-WAY**

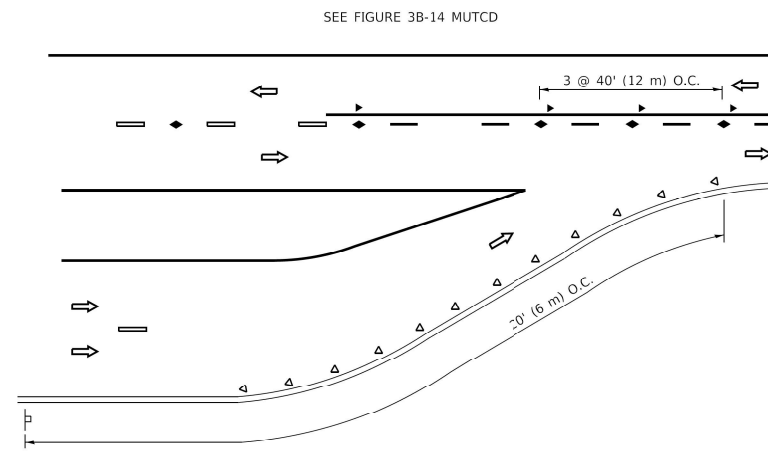

**LANE REDUCTION TRANSITION**

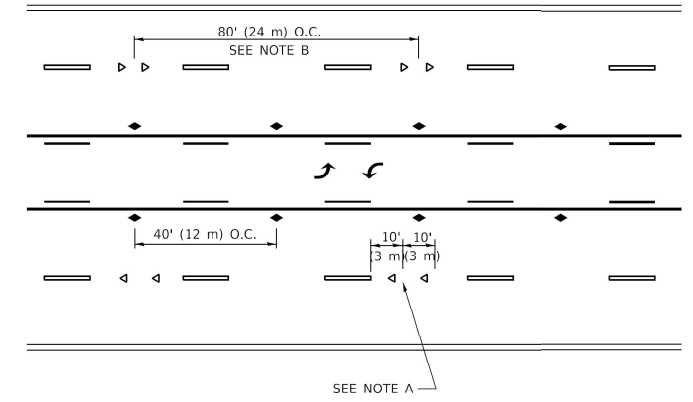

**TWO-WAY LEFT TURN**

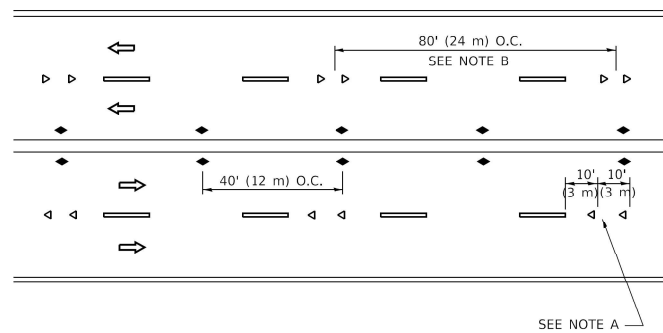

**MULTI-LANE/UNDIVIDED**

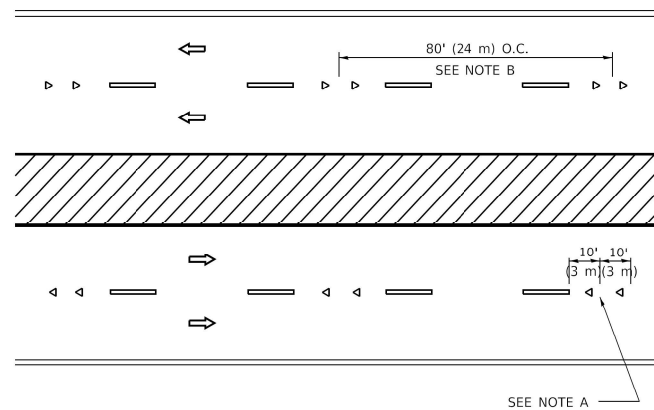

**MULTI-LANE/DIVIDED**

**GENERAL NOTES**

1. MARKERS USED WITH DASHED LINES SHALL BE CENTERED IN THE GAP BETWEEN SEGMENTS.
2. MARKERS USED ADJACENT TO SOLID LINES SHALL BE OFFSET 2 TO 3 (50 TO 75) TOWARD TRAFFIC AS SHOWN.
3. MARKERS THROUGH TANGENTS LESS THAN 500' (150 m) IN LENGTH BETWEEN CURVES SHALL BE INSTALLED AT THE LESSER OF THE TWO CURVE SPACINGS.
4. MARKERS ARE TO BE USED ADJACENT TO BOTH SOLID WHITE LINES IN DUAL LEFT TURN LANES

**SYMBOLS**

- YELLOW STRIPE
- WHITE STRIPE
- ◀ ONE-WAY AMBER MARKER
- ◀ ONE-WAY CRYSTAL MARKER (W/O)
- ◆ TWO WAY AMBER MARKER

**LANE MARKER NOTES**

- A. USE DOUBLE LANE LINE MARKERS SPACED AS SHOWN.
- B. REDUCE TO 40' (12 m) O.C. ON CURVES WHERE ADVISORY SPEEDS ARE 10 M.P.H (20 km/h) LOWER THAN POSTED SPEEDS.

**DESIGN NOTES**

1. DOUBLE LANE LINE MARKERS SHALL BE USED UNLESS SPECIFIED OTHERWISE.
2. EXCEPT AS SHOWN ON THE LANE REDUCTION TRANSITION AND FREEWAY EXIT RAMP DETAIL, MARKERS ARE NOT TO BE SPECIFIED ON RIGHT EDGE LINES.
3. THE EXACT MARKER LIMITS, SPACING, AND COLOR SHALL BE INCLUDED IN THE PLANS WHEN STANDARD SPECIFICATIONS ARE NOT BEING USED.
4. MARKERS SHOULD NOT BE USED ALONGSIDE CURBS EXCEPT FOR EXTREMELY SHORT SECTIONS OF CURBS WHERE NOT MORE THAN TWO MARKERS WOULD BE INVOLVED.

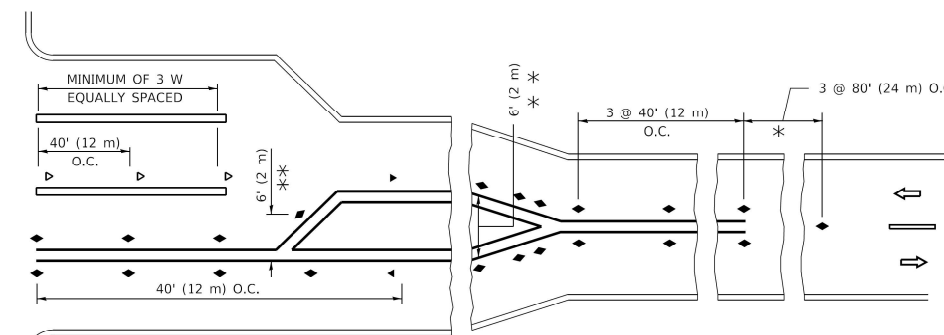
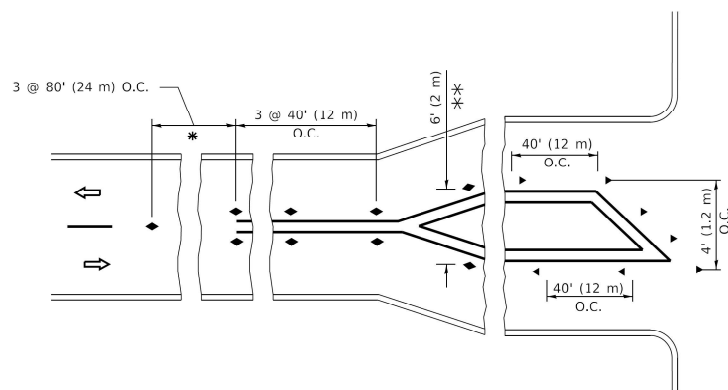

\* SEE TWO-LANE/TWO-WAY WHERE MARKERS CONTINUE  
 \*\* WHERE THE MEDIAN WIDTH IS 6' (2 m) OR LESS USE TWO-WAY MARKERS.

**TURN LANES**

All dimensions are in inches (millimeters) unless otherwise shown.

MODEL: TC-11  
 FILE NAME: C:\Engineering\Live\Projects\21003\_IDOT\_DUB\_HBR\WID - 62N43\CADD\CADD\_Sheets\CADD\62N43-01-01-01\_S04.dwg

USER NAME = footemj	DESIGNED -	REVISED - T. RAMMACHER 03-12-99
PLOT SCALE = 50.0000" / ft.	DRAWN -	REVISED - T. RAMMACHER 01-06-00
PLOT DATE = 3/4/2019	CHECKED -	REVISED - C. JUCIUS 09-09-09
	DATE -	REVISED - C. JUCIUS 07-01-13

**STATE OF ILLINOIS  
 DEPARTMENT OF TRANSPORTATION**

**TYPICAL APPLICATIONS  
 RAISED REFLECTIVE PAVEMENT MARKERS (SNOW-PLOW RESISTANT)**

SCALE: NONE SHEET 1 OF 1 SHEETS STA. TO STA.

F.A.P. RTE.	SECTION	COUNTY	TOTAL SHEETS	SHEET NO.
330	2021-030-R5	COOK	35	30
TC-11		CONTRACT NO. 62N43		
ILLINOIS FED. AID PROJECT 9P76(903)				

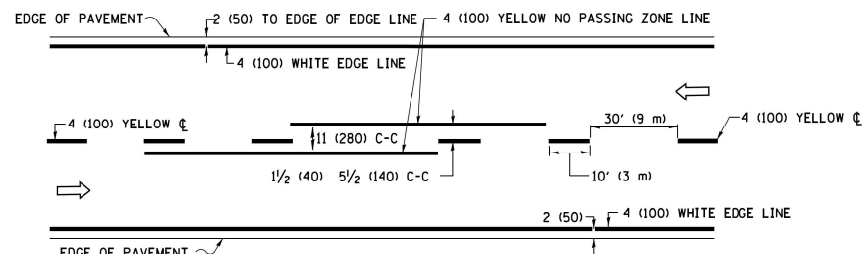

**2-LANE ROADWAY**

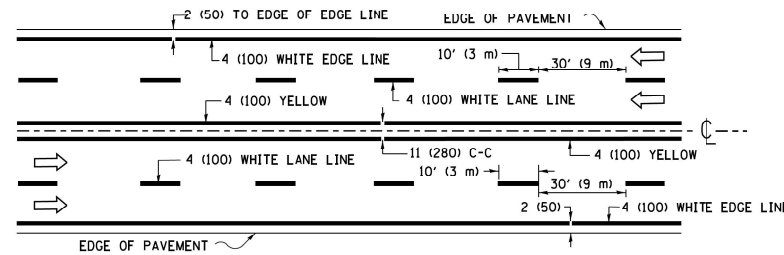

**MULTI-LANE UNDIVIDED**

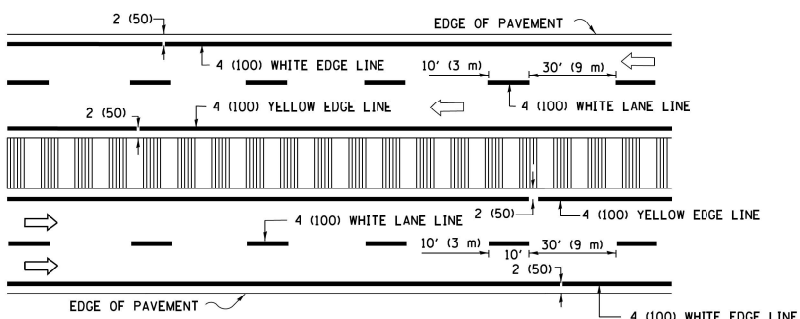

**MULTI-LANE DIVIDED WITH MEDIAN**

**TYPICAL LANE AND EDGE LINE MARKING**

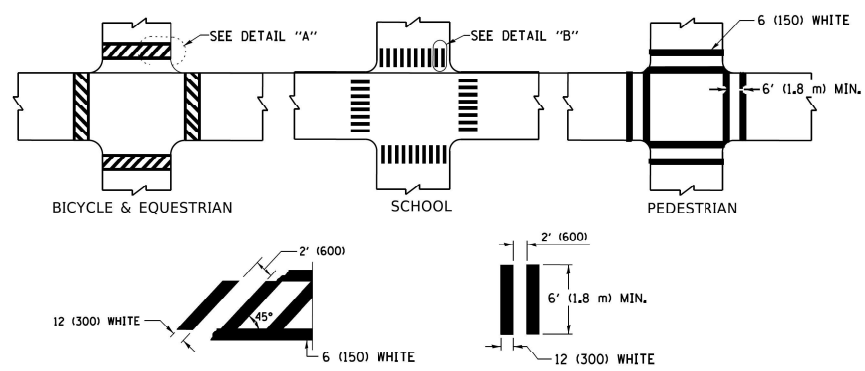

**TYPICAL CROSSWALK MARKING**

\* MARKINGS SHALL BE INSTALLED PARALLEL TO THE CENTERLINE OF THE ROAD WHICH IT CROSSES

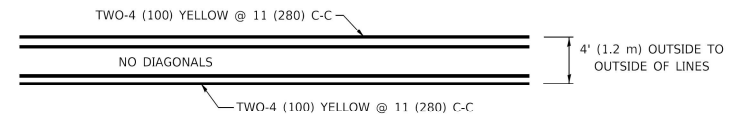

**4' (1.2 m) WIDE MEDIANS ONLY**

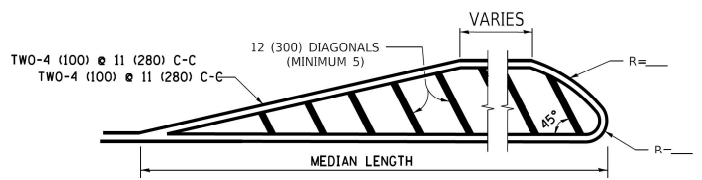

**MEDIANS OVER 4' (1.2 m) WIDE**

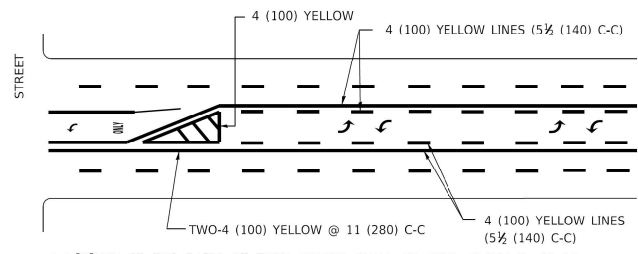

**MEDIAN WITH TWO-WAY LEFT TURN LANE TYPICAL PAINTED MEDIAN MARKING**

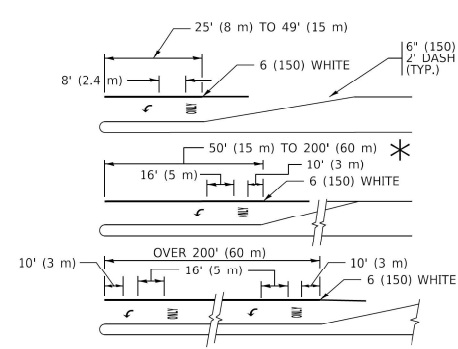

**TYPICAL LEFT (OR RIGHT) TURN LANE**

**TYPICAL TURN LANE MARKING**

FULL SIZE LETTERS 8' (2.4 m) AND ARROWS SHALL BE USED.  
 AREA = 15.6 SQ. FT. (1.5 m<sup>2</sup>) ONLY AREA = 20.8 SQ. FT. (1.9 m<sup>2</sup>)  
 \* TURN LANES IN EXCESS OF 400' (120 m) IN LENGTH MAY HAVE AN ADDITIONAL SET OF ARROW - "ONLY" INSTALLED MIDWAY BETWEEN THE OTHER TWO SETS OF ARROW - "ONLY".

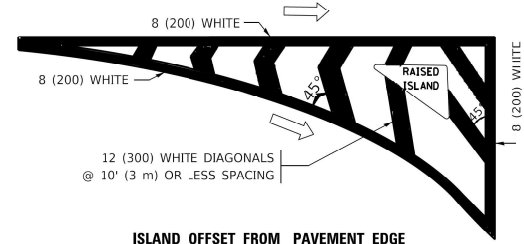

**ISLAND OFFSET FROM PAVEMENT EDGE**

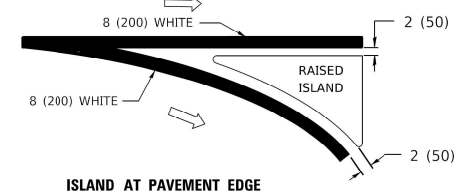

**ISLAND AT PAVEMENT EDGE**

**TYPICAL ISLAND MARKING**

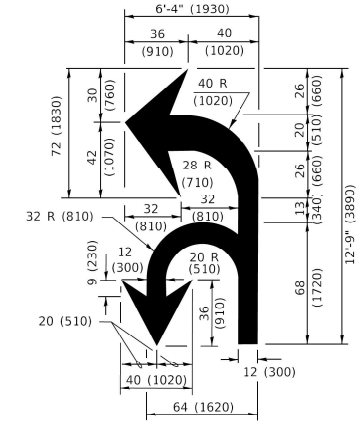

**COMBINATION LEFT AND U-TURN**

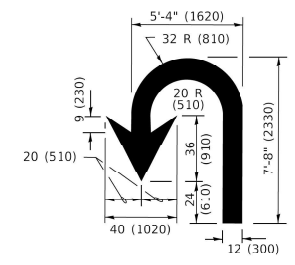

**U-TURN**

**LANE REDUCTION TRANSITION**  
 \* LANE REDUCTION ARROWS REQUIRED AT SPEEDS OF 45 MPH OR GREATER OR WHEN SPECIFIED IN PLANS.

D(FT)	SPEED LIMIT
345	30
425	35
500	40
580	45
665	50
750	55

TYPE OF MARKING	WIDTH OF LINE	PATTERN	COLOR	SPACING / REMARKS
CENTERLINE ON 2 LANE PAVEMENT	4 (100)	SKIP-DASH	YELLOW	10' (3 m) LINE WITH 30' (9 m) SPACE
CENTERLINE ON MULTI-LANE UNDIVIDED PAVEMENT	2 @ 4 (100)	SOLID	YELLOW	11 (280) C-C
NO PASSING ZONE LINES: FOR ONE DIRECTION FOR BOTH DIRECTIONS	4 (100) 2 @ 4 (100)	SOLID SOLID	YELLOW YELLOW	5 1/2 (140) C C FROM SKIP DASH CENTERLINE 11 (280) C-C OMIT SKIP-DASH CENTERLINE BETWEEN
LANE LINES	4 (100) 5 (125) ON FREEWAYS	SKIP-DASH SKIP-DASH	WHITE WHITE	10' (3 m) LINE WITH 30' (9 m) SPACE
DOTTED LINES (EXTENSIONS OF CENTER, LANE OR TURN LANE MARKINGS)	SAME AS LINE BEING EXTENDED	SKIP-DASH	SAME AS LINE BEING EXTENDED	2' (600) LINE WITH 6' (1.8 m) SPACE
EDGE LINES	4 (100)	SOLID	YELLOW-LEFT WHITE-RIGHT	OUTLINE MEDIANS IN YELLOW
TURN LANE MARKINGS	6 (150) LINE; FULL SIZE LETTERS & SYMBOLS (8' (2.4m))	SOLID	WHITE	SEE TYPICAL TURN LANE MARKING DETAIL
TWO WAY LEFT TURN MARKING	2 @ 4 (100) EACH DIRECTION 8' (2.4m) LEFT ARROW	SKIP-DASH AND SOLID IN PAIRS	YELLOW WHITE	10' (3 m) LINE WITH 30' (9 m) SPACE FOR SKIP-DASH; 5 1/2 (140) C-C BETWEEN SOLID LINE AND SKIP-DASH LINE SEE TYPICAL TWO-WAY LEFT TURN MARKING DETAIL
CROSSWALK LINES (PEDESTRIAN) A. DIAGONALS (BIKE & EQUESTRIAN) B. LONGITUDINAL BARS (SCHOOL)	2 @ 6 (150) 12 (300) @ 45° 12 (300) @ 90°	SOLID SOLID SOLID	WHITE WHITE WHITE	NOT LESS THAN 6' (1.8 m) APART 2' (600) APART 2' (600) APART SEE TYPICAL CROSSWALK MARKING DETAILS.
STOP LINES	24 (600)	SOLID	WHITE	PLACE 4' (1.2 m) IN ADVANCE OF AND PARALLEL TO CROSSWALK, IF PRESENT. OTHERWISE, PLACE AT DESIRED STOPPING POINT. PARALLEL TO CROSSROAD CENTERLINE, WHERE POSSIBLE
PAINTED MEDIANS	2 @ 4 (100) WITH 12 (300) DIAGONALS @ 45° NO DIAGONALS USED FOR 4' (1.2 m) WIDE MEDIANS	SOLID	YELLOW: TWO WAY TRAFFIC WHITE: ONE WAY TRAFFIC	11 (280) C-C FOR THE DOUBLE LINE SEE TYPICAL PAINTED MEDIAN MARKING.
GORE MARKING AND CHANNELIZING LINES	8 (200) WITH 12 (300) DIAGONALS @ 45°	SOLID	WHITE	DIAGONALS: 15' (4.5 m) C-C (LESS THAN 30MPH (50 km/h)) 20' (6 m) C-C 30MPH (50 km/h) TO 45MPH (70 km/h) 30' (9 m) C-C (OVER 45MPH (70 km/h))
RAILROAD CROSSING	24 (600) TRANSVERSE LINES: "RR" 15' 6" (1.8 m) LETTERS; 16 (400) LINE FOR "X"	SOLID	WHITE	SEE STATE STANDARD 780001 AREA OF: "R"=3.6 SQ. FT. (0.33 m <sup>2</sup> EACH) "X"=54.0 SQ. FT. (5.0 m <sup>2</sup> )
SHOULDER DIAGONALS (REQUIRED FOR SHOULDERS > 8')	12 (300) @ 45°	SOLID	WHITE - RIGHT YELLOW - LEFT	50' (15 m) C-C (LESS THAN 30MPH (50 km/h)) 75' (25 m) C-C (30 MPH (50 km/h) TO 45MPH (70 km/h)) 150' (45 m) C-C (OVER 45MPH (70 km/h))
U TURN ARROW	SEE DETAIL	SOLID	WHITE	16.3 SF
2 ARROW COMBINATION LEFT AND U TURN	SEE DETAIL	SOLID	WHITE	30.4 SF

FOR FURTHER DETAILS ON PAVEMENT MARKING REFER TO STANDARD SPECIFICATIONS FOR ROAD AND BRIDGE CONSTRUCTION AND STATE STANDARD 780001.

All dimensions are in inches (millimeters) unless otherwise shown.

MODEL: TC-13; FILE NAME: C:\Engineering\Live\Projects\1003\_IDOT\_DUB\_HBR\WDO\_1\_62N43\CADD\CADD\_Sheets\CADD\62N43-04-05R\_S04.dwg

USER NAME = footemj	DESIGNED - EVERS	REVISED - C. JUCIUS 09-09-09
PLOT SCALE = 50.0000" / 1ft.	DRAWN -	REVISED - C. JUCIUS 07-01-13
PLOT DATE = 3/4/2019	CHECKED -	REVISED - C. JUCIUS 12-21-15
	DATE - 03-19-90	REVISED - C. JUCIUS 04-12-16

**STATE OF ILLINOIS  
DEPARTMENT OF TRANSPORTATION**

<b>DISTRICT ONE</b>			
<b>TYPICAL PAVEMENT MARKINGS</b>			
SCALE: NONE	SHEET 1 OF 2 SHEETS	STA. TO STA.	

F.A.P. RTE. 330	SECTION 2021-030-R5	COUNTY COOK	TOTAL SHEETS 35	SHEET NO. 31
<b>TC-13</b>		CONTRACT NO. 62N43		
ILLINOIS FED. AID PROJECT 9P76(903)				

# TURN BAY ENTRANCE AT START OF LANE CLOSURE TAPER

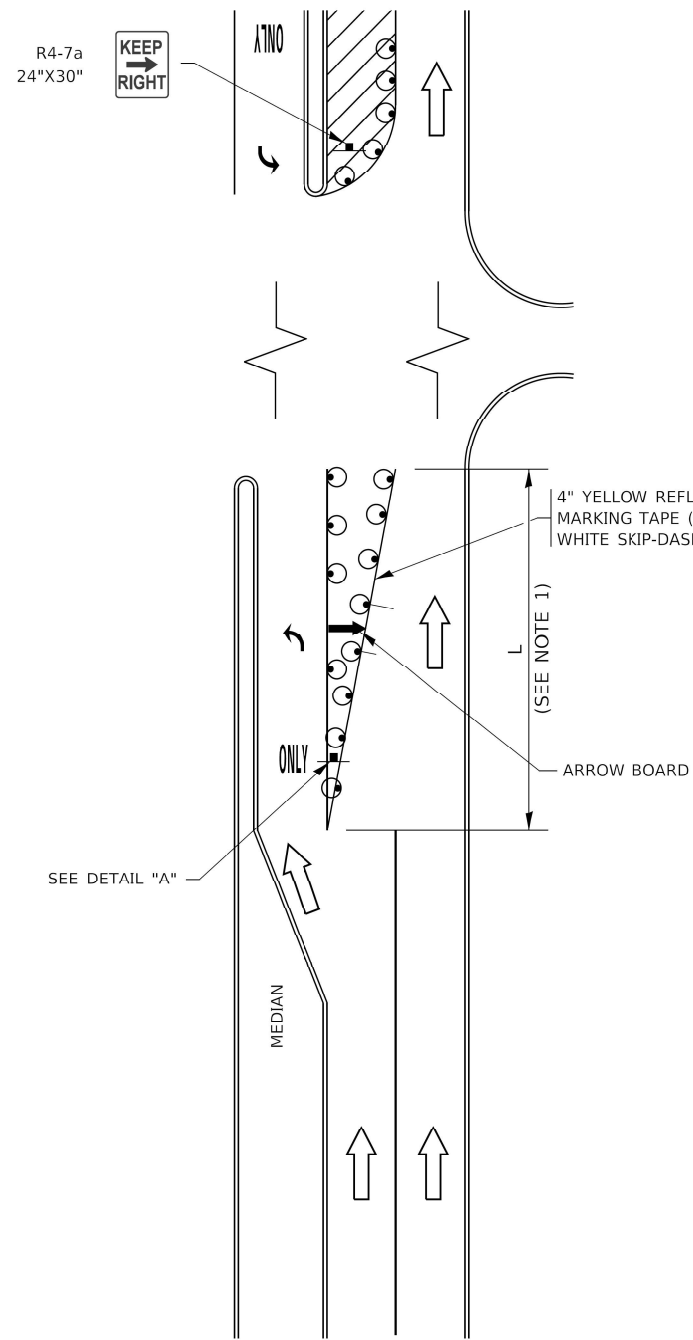

**FIGURE 1**

# TURN BAY ENTRANCE WITHIN A LANE CLOSURE

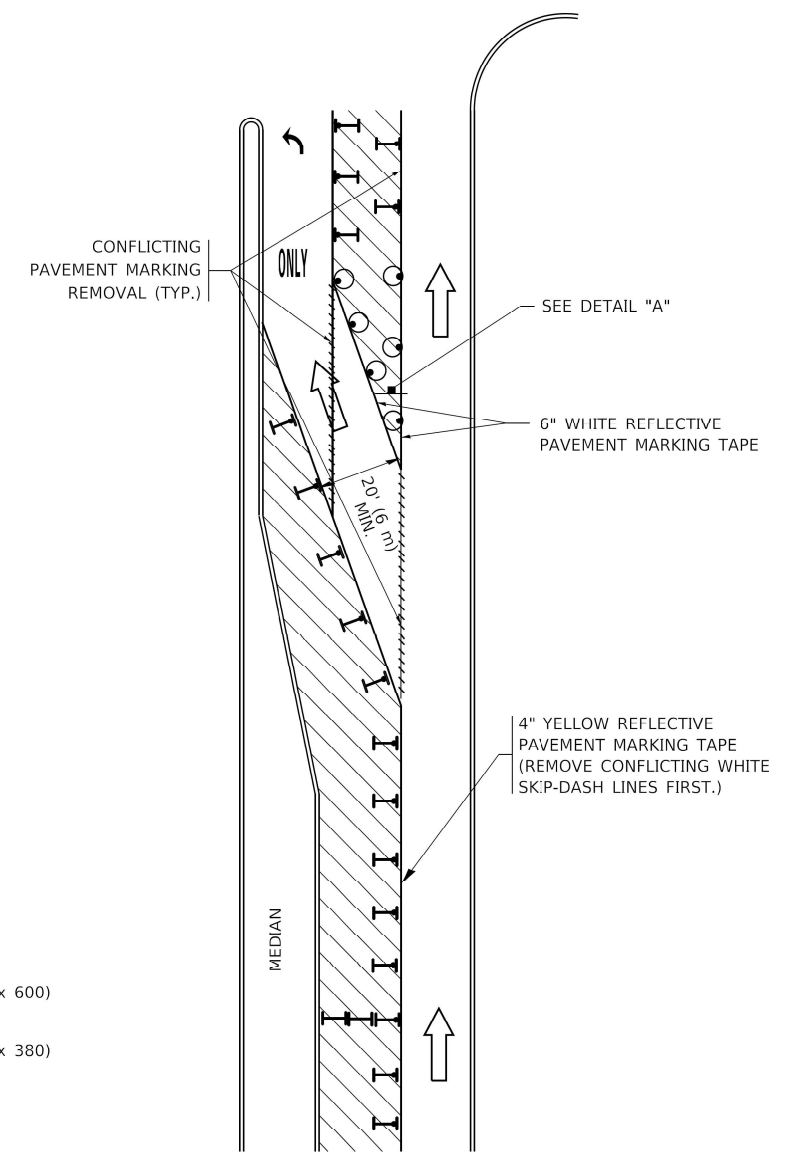

**FIGURE 2**

### LEGEND

- WORK AREA
- LANE OPEN TO TRAFFIC
- ARROW BOARD
- TYPE I OR II BARRICADE OR DRUM WITH STEADY BURN LIGHT
- DRUM WITH STEADY BURN LIGHT
- SIGN ASSEMBLY
- TYPE I OR II CHECK BARRICADE WITH FLASHING LIGHT

### NOTES:

1. A) WHEN "L" IS  $\leq$  THE STORAGE LENGTH OF THE TURN LANE (AS SHOWN IN FIG. 1), USE FIGURE 1.  
B) WHEN "L" IS  $>$  THE STORAGE LENGTH OF THE TURN LANE OR THE TURN LANE IS WITHIN THE LANE CLOSURE, USE FIGURE 2.
2. CONES MAY BE SUBSTITUTED FOR BARRICADES OR DRUMS AT HALF THE SPACING DURING DAY OPERATIONS. CONES SHALL BE A MINIMUM OF 28 (710) IN HEIGHT.
3. LIGHTS WILL NOT BE REQUIRED ON BARRICADES OR DRUMS FOR DAY OPERATIONS. ALL LIGHTS SHALL BE MONODIRECTIONAL.
4. REFLECTIVE TEMPORARY PAVEMENT MARKINGS SHALL BE PLACED THROUGHOUT THE BARRICADED AREAS OF EACH TURN BAY AS SHOWN WHERE THE CLOSURE TIME IS GREATER THAN FOURTEEN (14) DAYS.
5. THIS APPLICATION ALSO APPLIES WHEN WORK IS BEING PERFORMED IN THE RIGHT LANE(S) AND THE RIGHT TURN BAY IS TO REMAIN OPEN. UNDER THIS CONDITION, "RIGHT TURN LANE" R3-1100R 24 x 24 (600 x 600) AND M6-2R 21 x 15 (530 x 380) SHALL BE USED.
6. THESE CONTROLS SHALL SUPPLEMENT MAINLINE TRAFFIC CONTROL FOR LANE CLOSURES.
7. THE SIGNS SHALL BE MOUNTED ABOVE THE BARRICADES/DRUMS ON SEPARATE SIGN SUPPORTS THAT MEET NCHRP 350 OR MASH REQUIREMENTS.
8. TRAFFIC CONTROL AND PROTECTION AT TURN BAYS (TO REMAIN OPEN TO TRAFFIC) SHALL BE INCLUDED IN THE COST OF SPECIFIED TRAFFIC CONTROL STANDARDS OR ITEMS.

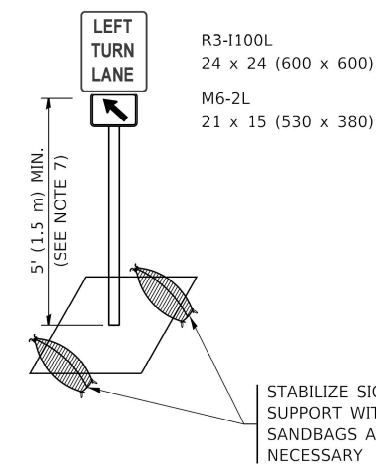

**DETAIL A**

All dimensions are in inches (millimeters) unless otherwise shown.

MODEL: TC-14  
FILE NAME: C:\Engineering\Live\Projects\21003\_IDOT\_DUB\_HBR\W01 - 62N43\CADD\CADD\_Sheets\C14R0162N43-01-01E\_S01.dwg

USER NAME = footemj	DESIGNED - T. RAMMACHER 09-08-94	REVISED - R. BORO 09-14-09
	DRAWN - A. HOUSEH 11-07-95	REVISED - A. SCHUETZE 07-01-13
PLOT SCALE = 50.0000' / in.	CHECKED - A. HOUSEH 10-12-96	REVISED - A. SCHUETZE 09-15-16
PLOT DATE = 3/4/2019	DATE - T. RAMMACHER 01-06-00	REVISED -

**STATE OF ILLINOIS  
DEPARTMENT OF TRANSPORTATION**

**TRAFFIC CONTROL AND PROTECTION AT TURN BAYS  
(TO REMAIN OPEN TO TRAFFIC)**

SCALE: NONE SHEET 1 OF 1 SHEETS STA. TO STA.

F.A.P. RTE.	SECTION	COUNTY	TOTAL SHEETS	SHEET NO.
330	2021-030-R5	COOK	35	32
TC-14		CONTRACT NO. 62N43		
ILLINOIS FED. AID PROJECT 9P76(903)				



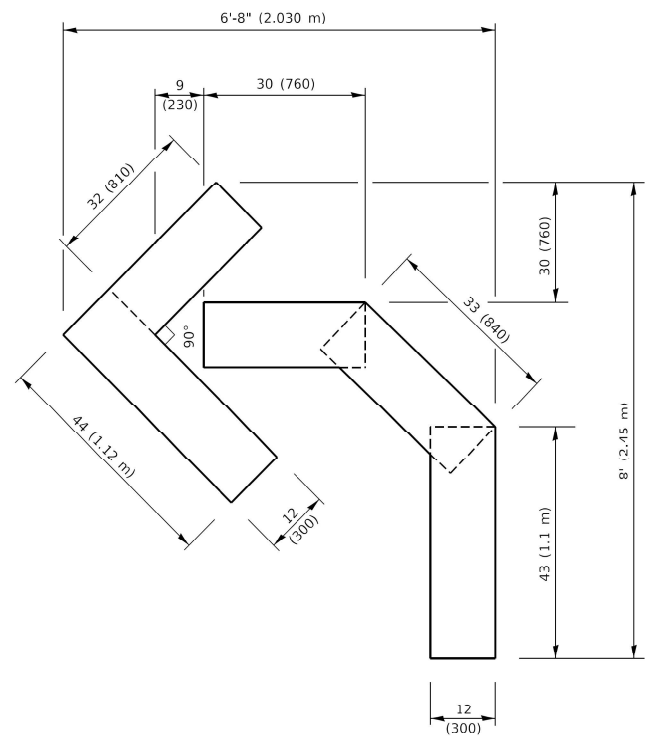

**QUANTITY**  
 4 (100) LINE = 45.5 ft. (13.9 m)  
 15.2 sq. ft. (1.41 sq. m)

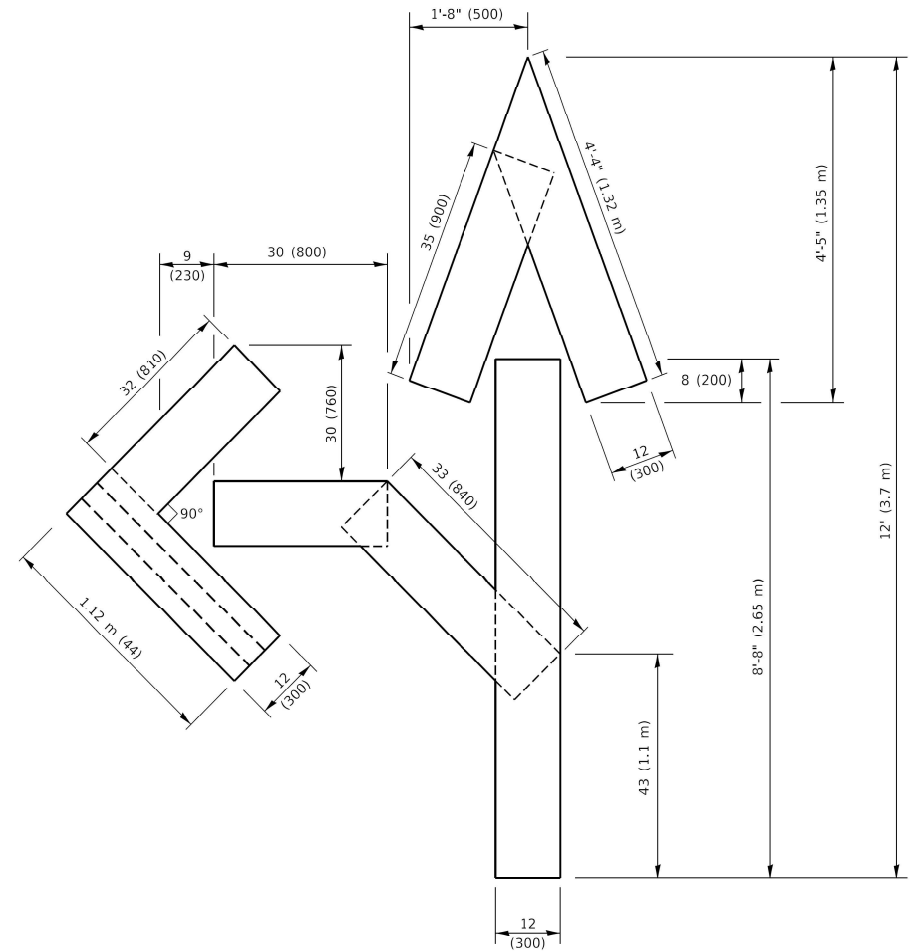

**QUANTITY**  
 4 (100) LINE = 82.5 ft. (25.1 m)  
 27.5 sq. ft. (2.53 sq. m)

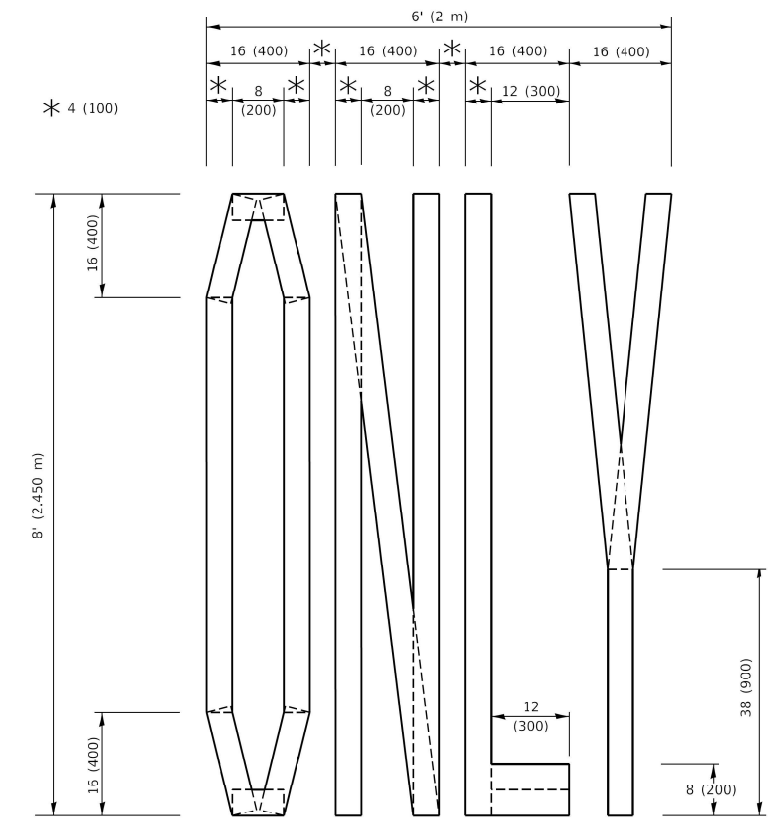

**QUANTITY**  
 4 (100) LINE = 64.1 ft. (19.5 m)  
 21.4 sq. ft. (1.99 sq. m)

**NOTE:**  
 ALL QUANTITIES OF PLACEMENT ARE REPRESENTED IN LINEAR FEET OF 4" LINES TO MATCH THE 4" TEMPORARY TAPE PAY ITEM AND REPRESENTS THE TOTAL QUANTITY OF 4" TAPE REQUIRED.

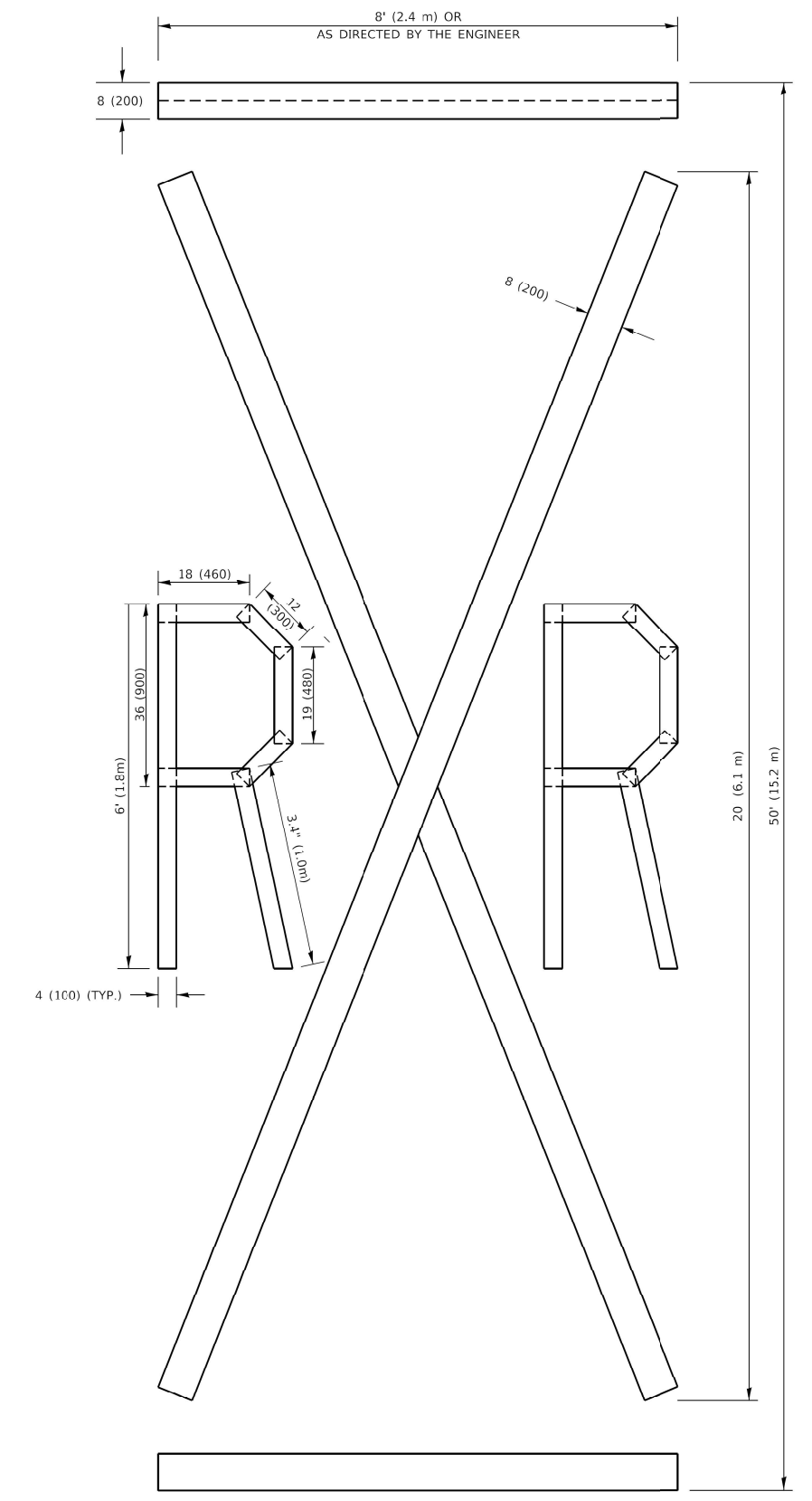

**QUANTITY**  
 4 (100) LINE = 225.9 ft. (68.9 m)  
 75.3 sq. ft. (6.99 sq. m)

All dimensions are in inches (millimeters) unless otherwise shown.

MODEL: TC-16  
 FILE NAME: C:\Engineering\LiveProjects\21003\_IDOT\_DUB\_HBR\WID-1-62\A3\CADD\CADD\_Sheets\C1\RD165\A3-INT-DEF\_Shts.dwg

USER NAME = footemj	DESIGNED -	REVISED - T. RAMMACHER 03-02-98
	DRAWN -	REVISED - E. GOMEZ 08-28-00
PLOT SCALE = 50.0068" / in.	CHECKED -	REVISED - E. GOMEZ 08-28-00
PLOT DATE = 3/4/2019	DATE - 09-18-94	REVISED - A. SCHUETZE 09-15-16

**STATE OF ILLINOIS  
 DEPARTMENT OF TRANSPORTATION**

**SHORT TERM PAVEMENT MARKING LETTERS AND SYMBOLS**

SCALE: NONE SHEET 1 OF 1 SHEETS STA. TO STA.

F.A.P. RTE.	SECTION	COUNTY	TOTAL SHEETS	SHEET NO.
330	2021-030-R5	COOK	35	33
<b>TC-16</b>		CONTRACT NO. 62N43		
ILLINOIS FED. AID PROJECT 9P76(903)				

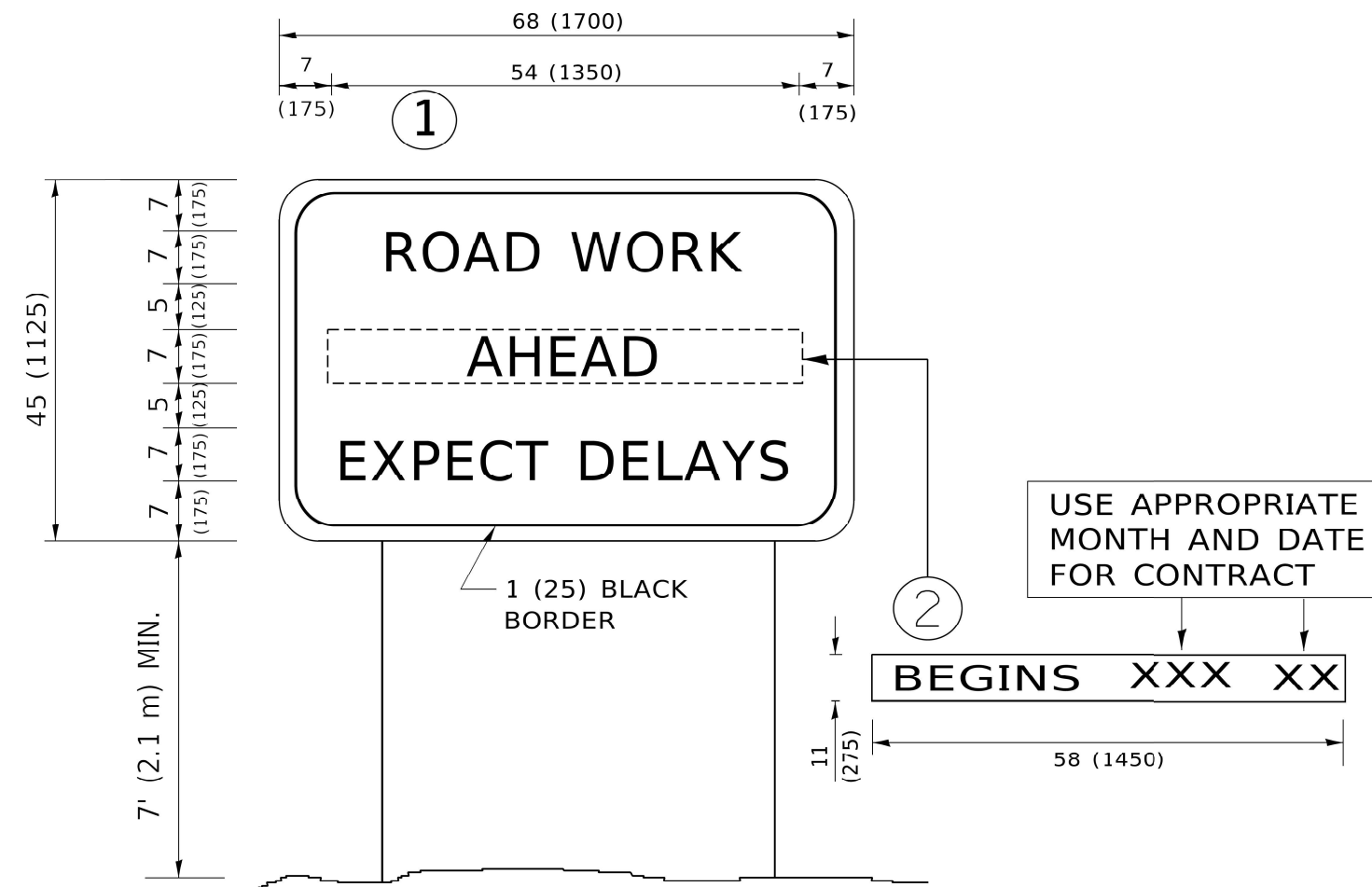

**NOTES:**

1. USE BLACK LETTERING ON ORANGE BACKGROUND.
2. ERECT SIGNS IN ADVANCE OF THE LOCATION FOR THE "ROAD CONSTRUCTION AHEAD" SIGN AT LOCATIONS AS DIRECTED BY THE ENGINEER.
3. ERECT SIGN ① WITH INSTALLED PANEL ② ONE WEEK PRIOR TO THE START OF CONSTRUCTION.
4. REMOVE PANEL ② SOON AFTER THE START OF CONSTRUCTION.
5. SEE SPECIAL PROVISION FOR "TEMPORARY INFORMATION SIGNING" FOR ADDITIONAL INFORMATION.
6. ONE SIGN ASSEMBLY EQUALS 25.70 SQ. FT. (2.3 SQ. M.)
7. SHALL BE PAID FOR AS TEMPORARY INFORMATION SIGNING.

ALL DIMENSIONS ARE IN INCHES (MILLIMETERS) UNLESS OTHERWISE SHOWN.

MODEL: TC-22  
FILE NAME: C:\Engineering\1\live\Project\1003\_IDOT\_DUB\_HBR\WID\_1 - 62N43\CADD\CADD\_Sheets\C1\RD163\N43-2019-08F\_S04.dgn

USER NAME = footemj	DESIGNED -	REVISED - R. MIRS 09-15-97
	DRAWN -	REVISED - R. MIRS 12-11-97
PLOT SCALE = 50.0000" / 1"	CHECKED -	REVISED - T. RAMMACHER 02-02-99
PLOT DATE = 3/4/2019	DATE -	REVISED - C. JUCIUS 01-31-07

**STATE OF ILLINOIS  
DEPARTMENT OF TRANSPORTATION**

**ARTERIAL ROAD  
INFORMATION SIGN**

SCALE: NONE SHEET 1 OF 1 SHEETS STA. TO STA.

F.A.P. RTE.	SECTION	COUNTY	TOTAL SHEETS	SHEET NO.
330	2021-030-R5	COOK	35	34
<b>TC-22</b>		CONTRACT NO. 62N43		
ILLINOIS FED. AID PROJECT 9P76(903)				

**LOOPS NEXT TO SHOULDERS**

PROVIDE A PAVEMENT REPLACEMENT NOTE WHICH SHOULD EQUAL 3' (900 mm) X WIDTH OF PAVED SHOULDER.

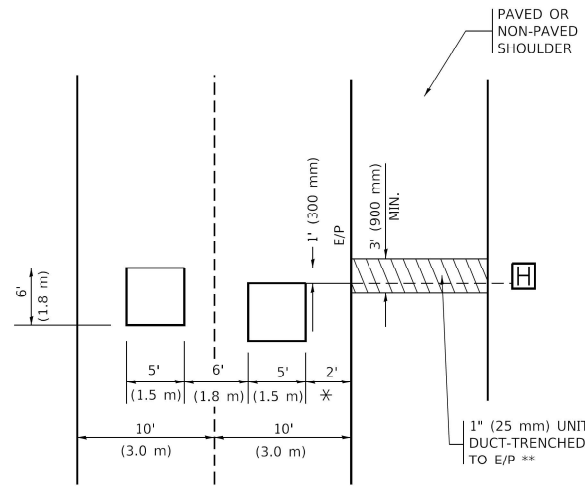

\* = (500 mm)

\*\* UNIT DUCT IS TO BE SHOWN ON PLAN SHEETS BUT SHALL NOT BE INCLUDED IN THE PAY ITEMS.

**LEFT TURN LANES WITH MEDIANS**

**VOLUME DENSITY ("FAR OUT" DETECTION) ON SAME APPROACH (PROTECTED / PERMITTED LEFT TURN PHASING)**

HANDHOLE LOCATION MAY VARY DEPENDING ON GEOMETRICS AND DESIGN OF TRAFFIC SIGNALS. HEAVY-DUTY HANDHOLES TO BE USED WHEN THE MEDIAN IS MOUNTABLE. REFER TO STANDARD 814001 TO ENSURE THAT HANDHOLE FITS IN MEDIAN.

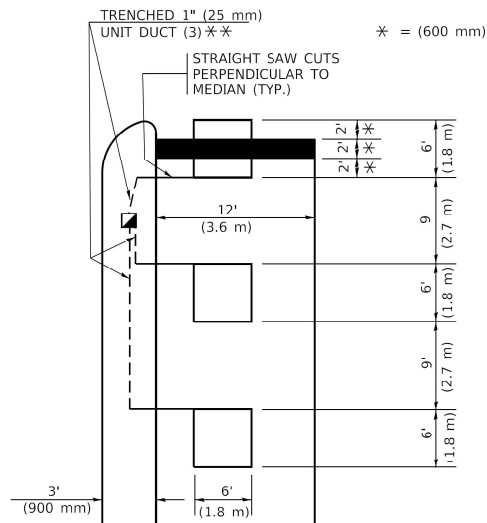

\* = (600 mm)

\*\* UNIT DUCT IS TO BE SHOWN ON PLAN SHEETS BUT SHALL NOT BE INCLUDED IN THE PAY ITEMS.

NOTE: DUAL LEFT TURNS NOT SHOWN REFER TO PLAN SHEET FOR DETECTOR LOOP REPLACEMENT

**LEFT TURN LANES WITHOUT MEDIANS**

**VOLUME DENSITY ("FAR OUT" DETECTION) ON SAME APPROACH (PROTECTED / PERMITTED LEFT TURN PHASING)**

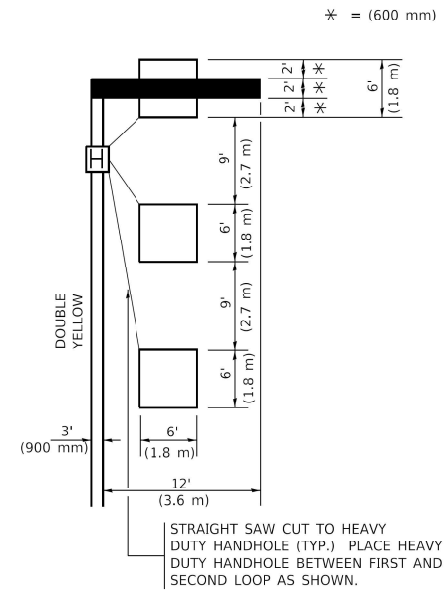

\* = (600 mm)

NOTE: DUAL LEFT TURNS NOT SHOWN REFER TO PLAN SHEET FOR DETECTOR LOOP REPLACEMENT

**NOTES:**

**VEHICLES LOOP DETECTORS**

- \* ALL LEAD IN CABLE SHALL BE TWO CONDUCTOR NO. 14 TWISTED, SHIELDED.
- \* EACH DETECTOR LOOP SHALL HAVE ITS OWN SAW CUT FROM THE LOOP TO THE EDGE OF PAVEMENT OR TO A HANDHOLE IN THE PAVEMENT.
- \* EACH DETECTOR LOOP SHALL HAVE ITS OWN ONE INCH (25 mm) UNIT DUCT BETWEEN THE EDGE OF PAVEMENT AND THE FIRST HANDHOLE OR JUNCTION BOX. EACH UNIT DUCT RUN SHALL BE SHOWN ON THE PLANS BY THE DESIGNER, BUT SHALL NOT BE PAID FOR SEPARATLY. THIS ITEM IS INCIDENTAL TO THE PAY ITEM FOR DETECTOR LOOPS.
- \* ONE DIMENSION OF ALL DETECTOR LOOPS SHALL BE SIX FEET (1.8 m)
- \* EACH LANE OF NON-LOCKING, PRESENCE DETECTION AND EACH LANE OF A DOUBLE LEFT TURN LANE REQUIRES A SEPARATE INDUCTIVE LOOP DETECTOR AND LEAD IN CABLE.
- \* WHEN NON-LOCKING, PRESENCE DETECTION IS USED, MORE THAN ONE LOOP PER LANE IS REQUIRED BEHIND THE STOP BAR (i.e. 1-1/2, 1-3/4, 2).
- \* WHEN SYSTEM LOOPS ARE REQUIRED ON AN APPROACH OF AN INTERSECTION, THE LOOPS USED FOR VOLUME DENSITY AND INTERSECTION TIMING SHALL ALSO BE USED AS SYSTEM DETECTORS. EACH ONE OF THESE TYPE OF LOOPS REQUIRES A SEPARATE TWO CONDUCTOR NO. 14 TWISTED SHIELDED CABLE AND A SEPARATE INDUCTIVE LOOP DETECTOR WHEN NEW CONTROLLERS ARE UTILIZED. THE DESIGNER SHALL LABEL THESE TYPES OF LOOPS AS "INTERSECTION AND SAMPLING (SYSTEM) DETECTORS" ON THE SIGNAL LAYOUT. THE INTERCONNECT PLAN AND THE SYSTEM CABLE PLAN. WHEN AN EXISTING CONTROLLER IS UTILIZED FOR THIS TYPE OF DETECTION, THE PAY ITEM "INDUCTIVE LOOP DETECTOR WITH SYSTEM OUTPUT" SHOULD BE USED.

**PLACEMENT OF DETECTORS**

THE FOLLOWING FIGURES REPRESENT THE MOST COMMON DETECTOR LOOP LOCATIONS AND SIZES. ADJUSTMENTS WILL BE NECESSARY FOR SPECIFIC GEOMETRIC CONSIDERATIONS.

LOCATIONS AND DEMENSIONS OF DETECTOR LOOPS ARE REQUIRED ON ALL SIGNAL LAYOUT PLAN SHEETS.

"FAR OUT" DETECTION REFERS TO LOCKING, PRESENCE TYPE DETECTION LOCATED IN THRU LANES, RIGHT TURN LANES, AND RIGHT TURN LANE TAPER AREAS (IF APPLICABLE), USUALLY 250' (75 m) IN ADVANCE OF STOP BARS. "UPTIGHT" DETECTION REFERS TO NON-LOCKING PRESENCE TYPE DETECTION LOCATED IN ALL LANES AND 10'-15' (3.0 m-4.5 m) BEHIND THE CROSSING STREET'S EDGE OF PAVEMENT EXTENDED.

**NOTE:**

ALL DETAILS AND NOTES SHOWN ARE FROM THE I.D.O.T. DISTRICT 1 TRAFFIC SIGNAL DESIGN GUIDELINES DATED JANUARY 1995

THIS DRAWING HAS BEEN PREPARED TO ASSIST THE RESIDENT ENGINEER FOR ALL ROADWAY RESURFACING OR S.M.A.R.T. PROJECTS WHERE THE DIMENSIONS ARE NOT SHOWN ON THE PLANS AND THE FINAL LOCATIONS FOR CROSSWALKS OR STOP BARS ARE NOT DETERMINED.

**ARTERIAL-VOLUME DENSITY ("FAR OUT" DETECTION) CROSS STREET-NON VOLUME DENSITY ("FAR OUT" DETECTION)**

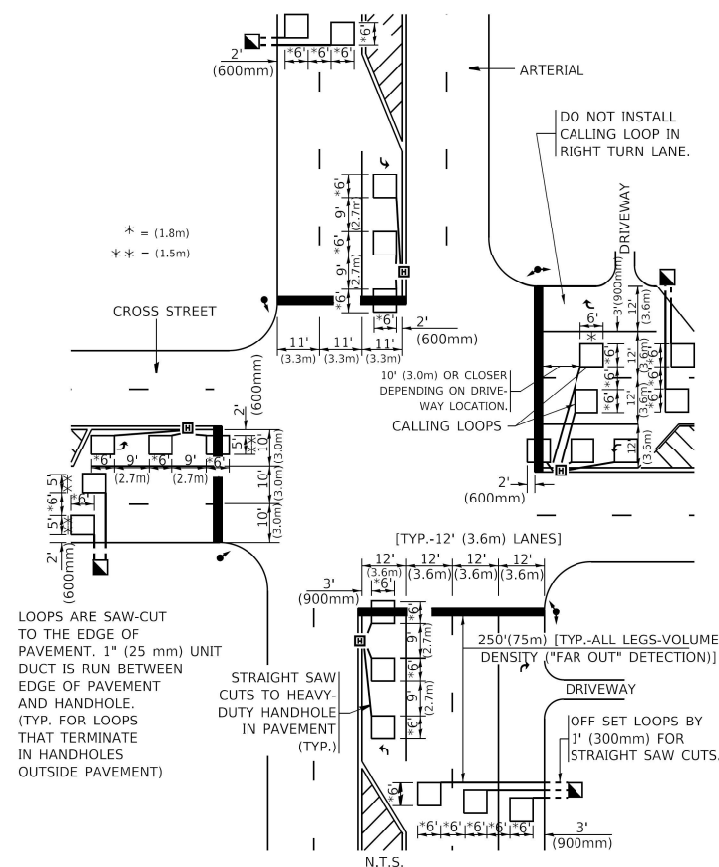

**DETAIL 1**  
N.T.S.

**ARTERIAL-VOLUME DENSITY ("FAR OUT" DETECTION) CROSS STREET-NON VOLUME DENSITY ("UPTIGHT" PRESENCE DETECTION)**

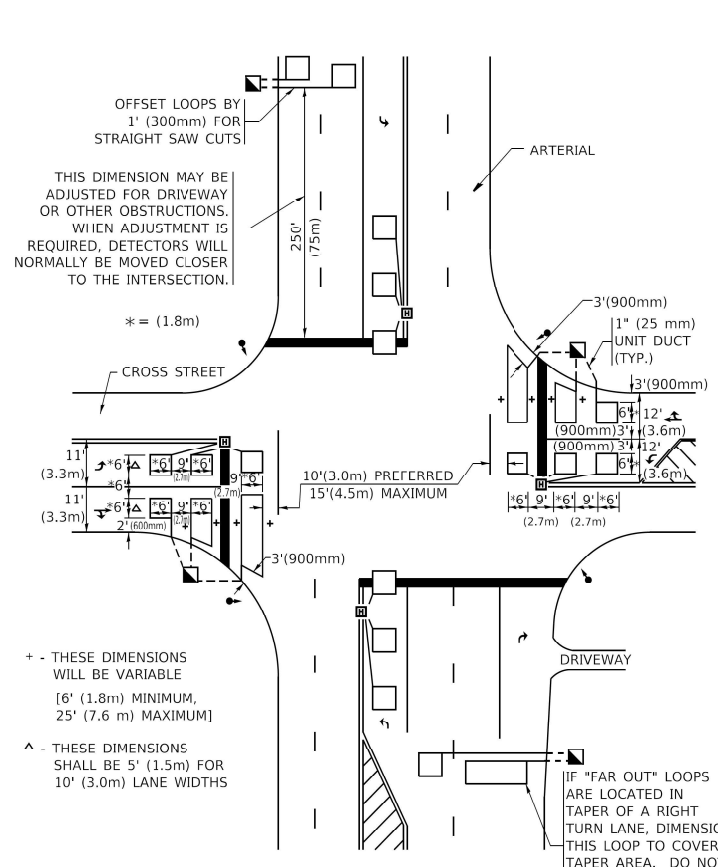

**DETAIL 2**  
N.T.S.

MODEL: T6-07  
FILE NAME: Co\_Engineering\Live\Projects\1003\_IDOT\_DUB\_HBR\VID\_1\_62N43\CADD\CADD\_Sheets\CADD\62N43-2R-05R\_Shts.dwg

USER NAME = footemj	DESIGNED -	REVISED -
PLOT SCALE = 50.0000' / in.	DRAWN -	REVISED -
PLOT DATE = 3/4/2019	CHECKED - R.K.F.	REVISED -
	DATE -	REVISED -

DESIGNED -	REVISED -
DRAWN -	REVISED -
CHECKED - R.K.F.	REVISED -
DATE -	REVISED -

DESIGNED -	REVISED -
DRAWN -	REVISED -
CHECKED - R.K.F.	REVISED -
DATE -	REVISED -

**STATE OF ILLINOIS**  
**DEPARTMENT OF TRANSPORTATION**

**DISTRICT 1 - DETECTOR LOOP INSTALLATION**  
**DETAILS FOR ROADWAY RESURFACING**

SCALE: NONE SHEET 1 OF 1 SHEETS STA. TO STA.

F.A.P. RTE.	SECTION	COUNTY	TOTAL SHEETS	SHEET NO.
330	2021-030-R5	COOK	35	35
<b>TS-07</b>		CONTRACT NO. 62N43		
ILLINOIS FED. AID PROJECT 9P76(903)				