

TYPICAL END TREATMENT AT SIDEWALK OR MEDIAN
 Shorter plates with a single row of studs at 12" cts. may be necessary on medians which are shallower than 9". See manufacturer's recommendation.

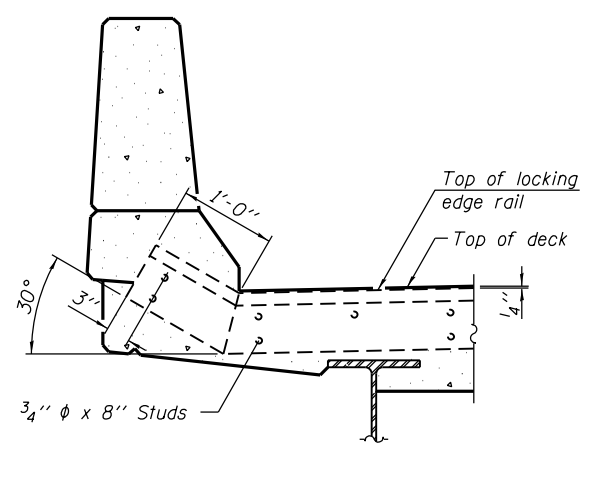

SECTION A-A

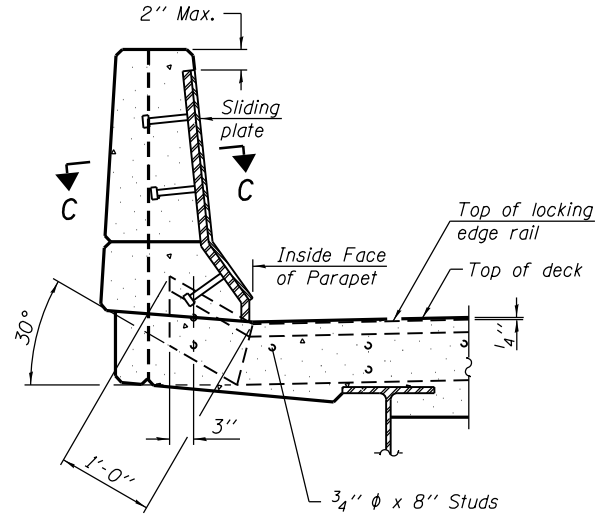

SECTION B-B

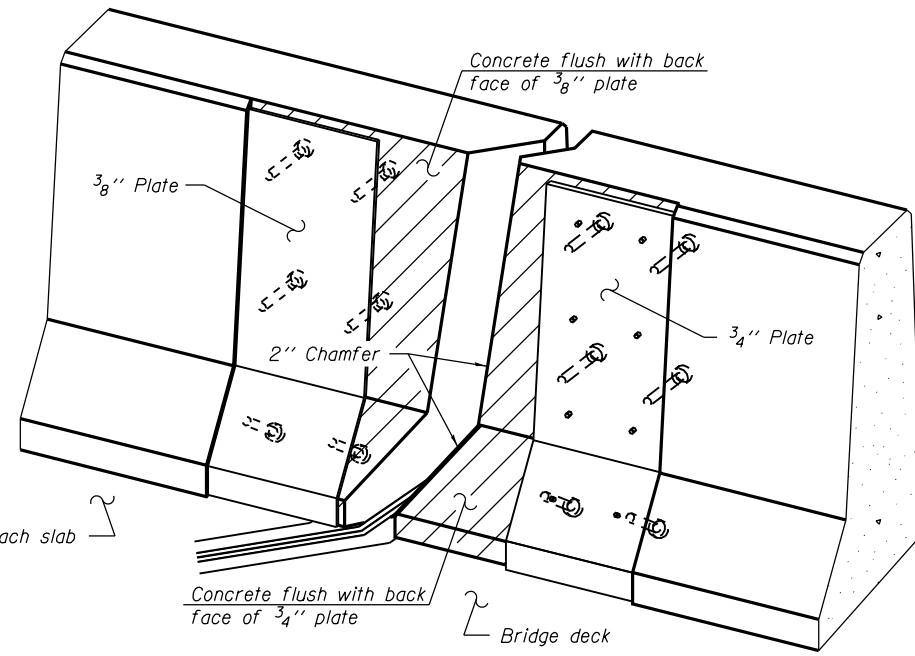

TRIMETRIC VIEW (Showing back plates only)

NOTES:

The strip seal shall be made continuous and shall have a minimum thickness of 1/4". The configuration of the strip seal shall match the configuration of the Locking Edge Rails. Open or "webbed" strip seal gland configurations are not permitted. The gland shall be sized for a maximum rated movement of 4 inches.
 The Locking Edge Rails depicted are conceptual only, except for the minimum dimensions shown. The actual configuration of the Locking Edge Rails and matching strip seal may vary from manufacturer to manufacturer. Flanged edge rails will not be allowed. Locking Edge Rails may be spliced at slope discontinuities.
 The manufacturer's recommended installation methods shall be followed.
 The joint opening and deck dimensions detailed on the superstructure are based on a rolled rail expansion joint. If the Contractor elects to use the welded rail expansion joint, the opening and deck dimensions shall be modified according to the dimensions detailed on this sheet. Required modifications shall be made at no additional cost to the State.

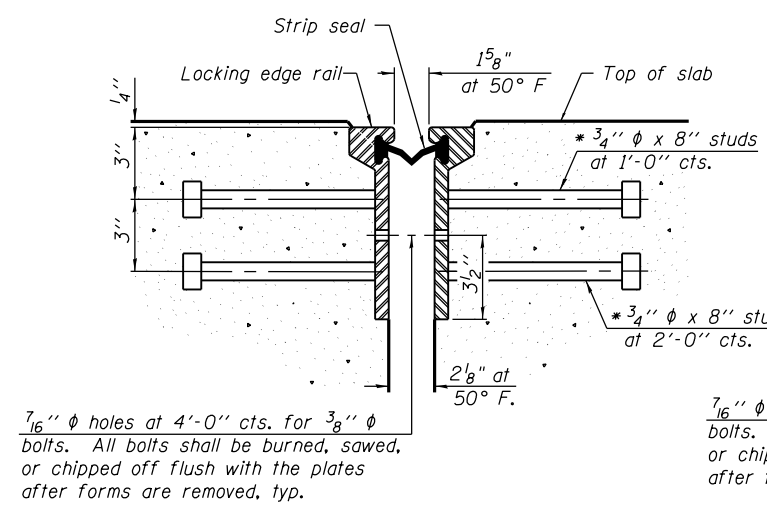

SECTION THRU ROLLED RAIL JOINT

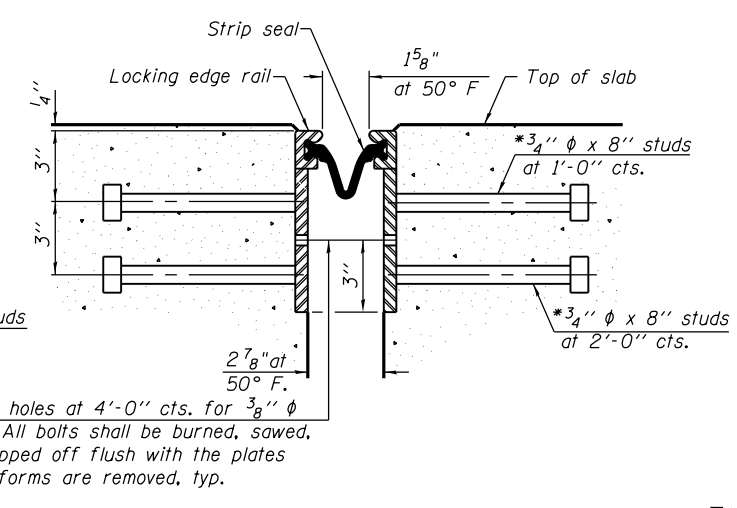

SECTION THRU WELDED RAIL JOINT

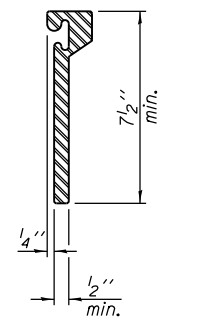

ROLLED EXTRUDED RAIL

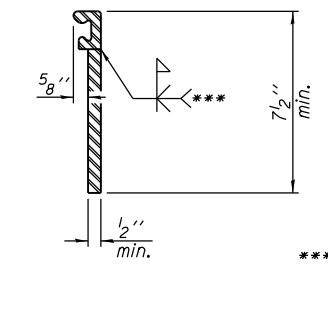

WELDED RAIL

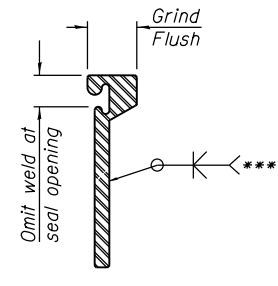

LOCKING EDGE RAIL SPLICE

*** Back gouge not required if complete joint penetration is verified by mock-up.

The inside of the locking edge rail groove shall be free of weld residue.
 Rolled rail shown, welded rail similar.

LOCKING EDGE RAILS

BILL OF MATERIAL

Item	Unit	Total
Preformed Joint Strip Seal	Foot	39.0

* Granular or solid flux filled headed studs conforming to Article 1006.32 of the Std. Specs., automatically end welded.

EJ-SSJ

1-27-12



USER NAME = floresg	DESIGNED - VP	REVISED
PLOT SCALE = N.T.S.	CHECKED - EJO	REVISED
PLOT DATE = 5/7/2014	DRAWN - VP	REVISED
	CHECKED - EJO	REVISED

STATE OF ILLINOIS
 DEPARTMENT OF TRANSPORTATION

EXPANSION JOINT - SOUTH ABUTMENT
 STRUCTURE NO. 016-1705

SHEET NO. S-64 OF S-165 SHEETS

F.A.I. RTE. 90/94/290	SECTION 2013-010R	COUNTY COOK	TOTAL SHEETS 747	SHEET NO. 380
CONTRACT NO. 60W28			ILLINOIS FED. AID PROJECT	

0161705-60W28-S064-ExpJoint.dgn