

07-29-2016 LETTING ITEM 070

FOR INDEX OF SHEETS, SEE SHEET NO. 3

STATE OF ILLINOIS
DEPARTMENT OF TRANSPORTATION

F.A. RTE.	SECTION	COUNTY	TOTAL SHEETS	SHEET NO.
**	D9 CM PATCH 2017-3	VARIOUS	10	1
		ILLINOIS	CONTRACT NO. 78539	
** 157/ IL 145				

I-57 2016 ADT

PV 7,245

SU 630

MU 5,355

ADT 13,230

PROPOSED HIGHWAY PLANS

FAI 57 & FAP 132 (I-57 & IL 145)
SECTION D9 CM PATCH 2017-3

PATCHING
ALEXANDER, PULASKI & POPE COUNTIES

D-99-041-16

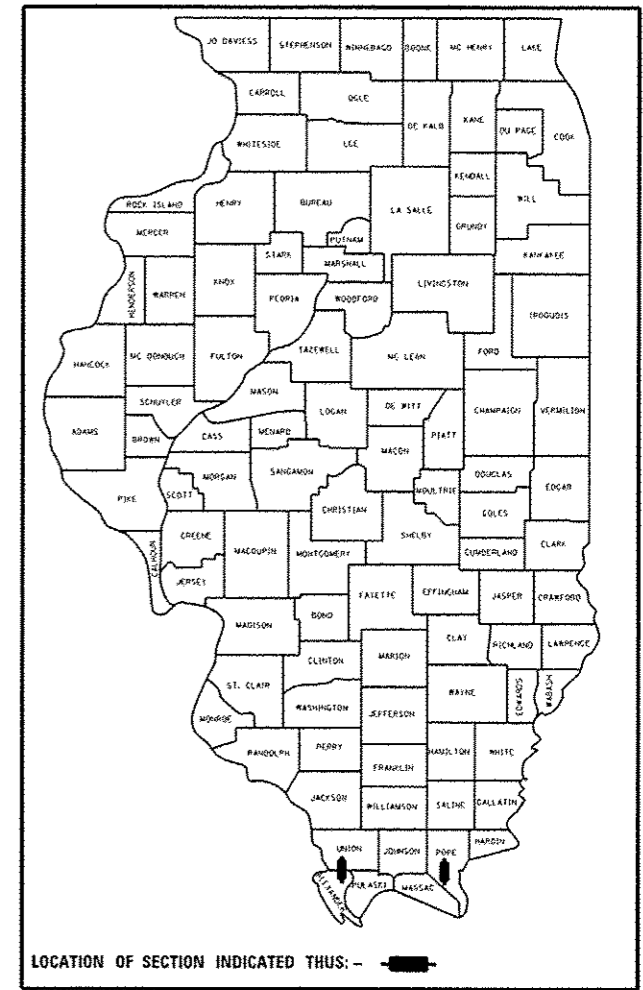

C-99-041-16

IMPROVEMENT BEGINS

IMPROVEMENT ENDS

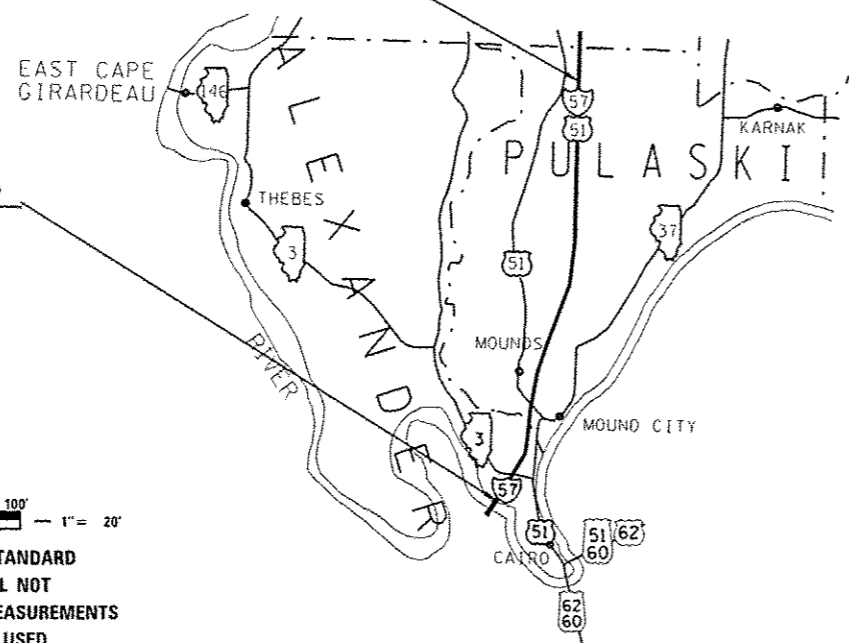

IMPROVEMENT BEGINS

IMPROVEMENT ENDS

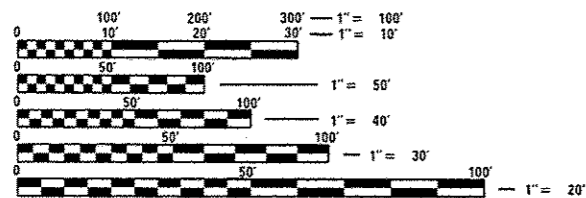
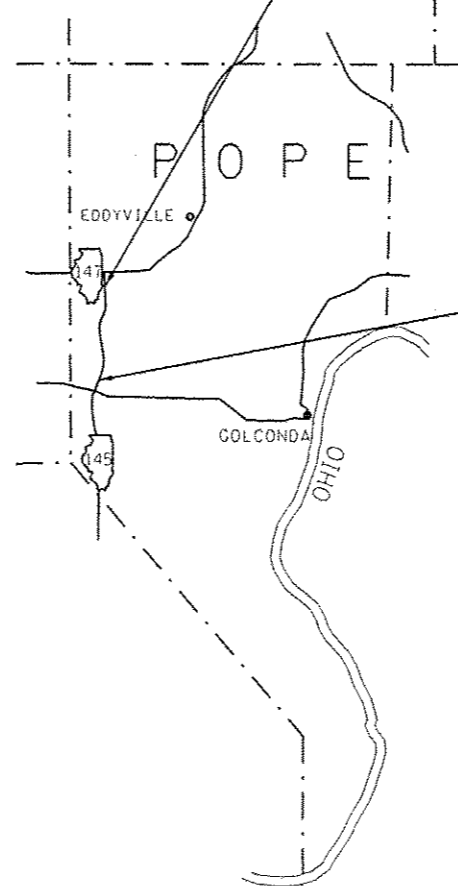

FULL SIZE PLANS HAVE BEEN PREPARED USING STANDARD ENGINEERING SCALES. REDUCED SIZED PLANS WILL NOT CONFORM TO STANDARD SCALES. IN MAKING MEASUREMENTS ON REDUCED PLANS, THE ABOVE SCALES MAY BE USED.

J.U.L.I.E.
JOINT UTILITY LOCATION INFORMATION FOR EXCAVATION
1-800-892-0123
OR 811

PROJECT ENGINEER LISA PRITCHETT
PROJECT MANAGER CHARLES STEIN

CONTRACT NO. 78539

STATE OF ILLINOIS
DEPARTMENT OF TRANSPORTATION

SUBMITTED May 4 2016

Jeffrey Z Keen
REGIONAL ENGINEER

July 1 2016
Maureen M. Addis PE
ENGINEER OF DESIGN AND ENVIRONMENT

July 1 2016
Michelle Allen
DIRECTOR OF PROGRAM DEVELOPMENT

PRINTED BY THE AUTHORITY
OF THE STATE OF ILLINOIS

Prepared By:

DISTRICT STUDIES & PLANS ENGINEER

Examined By:

DISTRICT LAND ACQUISITION ENGINEER

Examined By:

DISTRICT PROGRAM DEVELOPMENT ENGINEER

Examined By:

DISTRICT OPERATIONS ENGINEER

Examined By:

DISTRICT PROJECT IMPLEMENTATION ENGINEER

Examined By:

DISTRICT CONSTRUCTION ENGINEER

Examined By:

DISTRICT MATERIALS ENGINEER

FILE NAME :	USER NAME :	DESIGNED :	REVISED :
p:\1\1064EBID\FCD\Illinois\go\PM007\09	* gntc@ctll	-	-
	PROJECT :	ORIGIN :	REVISED :
	ISST Office District 9 Projects 78539	ORIGIN (448494) 78539.dwg	-
#MODELNAME#	PLOT SCALE :	CHECKED :	REVISED :
	1:82.9963 / in.	-	-
	PLOT DATE :	DATE :	REVISED :
	4/26/2016	-	-

STATE OF ILLINOIS
DEPARTMENT OF TRANSPORTATION

SIGNATURE SHEET

SCALE:	SHEET	OF	SHEETS	STA.	TO STA.	F.A. RTE.	SECTION	COUNTY	TOTAL SHEETS	SHEET NO.
						**	09 CM PATCH 2017-3	VARIOUS	10	2
									CONTRACT NO. 78539	
ILLINOIS FED. AID PROJECT										

SUMMARY OF QUANTITIES

COUNTY:	ALEXANDER	PULASKI	POPE
ROUTE:	I-57		IL 145
FUNDING:	100% STATE		100% STATE
LOCATION:	RURAL		RURAL
TOTAL QUANTITY	ROADWAY 0005		ROADWAY 0005

CODE NUMBER	ITEM DESCRIPTION	UNIT	TOTAL QUANTITY	ROADWAY 0005	ROADWAY 0005
44004250	PAVED SHOULDER REMOVAL	SQ YD	113	113	
44200050	WELDED WIRE REINFORCEMENT	SQ YD	1,045		1,045
44200529	CLASS A PATCHES, TYPE II, 8 INCH	SQ YD	53	53	
44200533	CLASS A PATCHES, TYPE III, 8 INCH	SQ YD	16	16	
44200535	CLASS A PATCHES, TYPE IV, 8 INCH	SQ YD	67	67	
44200616	CLASS A PATCHES, TYPE I, 14 INCH	SQ YD	57		57
44200620	CLASS A PATCHES, TYPE II, 14 INCH	SQ YD	90		90
44200628	CLASS A PATCHES, TYPE IV, 14 INCH	SQ YD	27		27
44201361	CLASS C PATCHES, TYPE I, 11 INCH	SQ YD	43		43
44201365	CLASS C PATCHES, TYPE II, 11 INCH	SQ YD	209		209
44201369	CLASS C PATCHES, TYPE III, 11 INCH	SQ YD	64		64
44201371	CLASS C PATCHES, TYPE IV, 11 INCH	SQ YD	981		981

12

SUMMARY OF QUANTITIES - CONT

COUNTY:	ALEXANDER	PULASKI	POPE
ROUTE:	I-57		IL 145
FUNDING:	100% STATE		100% STATE
LOCATION:	RURAL		RURAL
TOTAL QUANTITY	ROADWAY 0005		ROADWAY 0005

CODE NUMBER	ITEM DESCRIPTION	UNIT	TOTAL QUANTITY	ROADWAY 0005		ROADWAY 0005
44213000	PATCHING REINFORCEMENT	SQ YD	310	136	174	
44213200	SAW CUTS	FOOT	1,863	588	1,275	
44213204	TIE BARS 3/4"	EACH	35	25	10	
48101200	AGGREGATE SHOULDERS, TYPE B	TON	4	4		
48203029	HOT-MIX ASPHALT SHOULDERS, 8"	SQ YD	113	113		
60100080	FRENCH DRAINS	CU YD	32	32		
60100085	GEOTECHNICAL FABRIC FOR FRENCH DRAINS	SQ YD	198	198		
67100100	MOBILIZATION	LSUM	1	0.33	0.33	0.33
70100420	TRAFFIC CONTROL AND PROTECTION, STANDARD 701411	EACH	6		6	
70100600	TRAFFIC CONTROL AND PROTECTION, STANDARD 701336	LSUM	1			1
70100800	TRAFFIC CONTROL AND PROTECTION, STANDARD 701401	LSUM	1	0.5	0.5	
70106800	CHANGEABLE MESSAGE SIGN	CAL MO	5	1.0	1.5	2.5
X7010410	SPEED DISPLAY TRAILER	CAL MO	2	1.0	1.0	

I-57 PATCHING SCHEDULE

LOCATION	LENGTH	WIDTH	CLASS A PATCHES, TYPE II, 8 INCH	CLASS A PATCHES, TYPE III, 8 INCH	CLASS A PATCHES, TYPE IV, 8 INCH	CLASS A PATCHES, TYPE I, 14 INCH	CLASS A PATCHES, TYPE II, 14 INCH	CLASS A PATCHES, TYPE IV, 14 INCH	SAW CUTS	TIE BARS, 3/4"	PATCHING REINFORCEMENT
	FOOT	FOOT	SQ YD	SQ YD	SQ YD	SQ YD	SQ YD	SQ YD	FOOT	EACH	SQ YD
INTERSTATE 57 (ALEXANDER COUNTY)											
SN 002-0025											
SOUTHBOUND DRIVING LANE											
	7	12	9						62		9
	12	12		16					72		16
	6	12	8						60		8
NORTHBOUND DRIVING LANE											
	50	12			67				148	25	67
	6	12	8						60		8
NORTHBOUND PASSING LANE											
	7	12	9						62		9
	7	12	9						62		9
	7	12	9						62		9
SUB-TOTAL											
			53	16	67	0	0	0	588	25	136

I-57 PATCHING SCHEDULE

LOCATION	LENGTH	WIDTH	CLASS A PATCHES, TYPE II, 8 INCH	CLASS A PATCHES, TYPE III, 8 INCH	CLASS A PATCHES, TYPE IV, 8 INCH	CLASS A PATCHES, TYPE 1, 14 INCH	CLASS A PATCHES, TYPE II, 14 INCH	CLASS A PATCHES, TYPE IV, 14 INCH	SAW CUTS	TIE BARS, 3/4"	PATCHING REINFORCEMENT
	FOOT	FOOT	SQ YD	SQ YD	SQ YD	SQ YD	SQ YD	SQ YD	FOOT	EACH	SQ YD
INTERSTATE 57 (PULASKI COUNTY)											
MOUNDS INTERCHANGE											
SOUTHBOUND DRIVING LANE											
	6	6				4			36		4
	6	6				4			36		4
	6	6				4			36		4
	6	6				4			36		4
	6	6				4			36		4
	6	6				4			36		4
	6	6				4			36		4
	6	6				4			36		4
	6	6				4			36		4
	6	6				4			36		4
	6	6				4			36		4
	6	6				4			36		4
	6	6				4			36		4
	6	6				4			36		4
	6	6				4			36		4
	6	6				4			36		4
	6	12					8		60		8
	6	12					8		60		8
	6	12					8		60		8
	6	12					8		60		8
	6	12					8		60		8
	6	12					8		60		8
	6	12					8		60		8
	20	12						27	88	10	27
NORTHBOUND DRIVING LANE											
	8	6					5		39		5
	7	6				5			38		5
	10	6					7		44		7
ULLIN INTERCHANGE											
SOUTHBOUND DRIVING LANE											
	5	12					7		58		7
	6	12					8		60		8
	6	12					8		60		8
PROJECT TOTAL			53	16	67	57	90	27	1863	35	310

IL 145 PATCHING SCHEDULE

LOCATION	LENGTH	WIDTH	CLASS C PATCHES, TYPE I, 11 INCH	CLASS C PATCHES, TYPE II, 11 INCH	CLASS C PATCHES, TYPE III, 11 INCH	CLASS C PATCHES, TYPE IV, 11 INCH	WELDED WIRE REINFORCEMENT
	FOOT	FOOT	SQ YD	SQ YD	SQ YD	SQ YD	SQ YD
SOUTHBOUND LANE							
	6	6	4				
	29	11				35	35
	6	6	4				
	6	11		7			
	6	11		7			
	180	11				220	220
	220	11				269	269
	90	11				110	110
	10	6		7			
	10	11		12			
	10	11		12			
	90	11				110	110
	60	11				73	73
	6	11		7			
	6	11		7			
	6	6	4				
	6	6	4				
	20	11			24		24
	70	6				47	47
	10	11		12			
SUB-TOTAL			16	73	24	864	889

LOCATION	LENGTH	WIDTH	CLASS C PATCHES, TYPE I, 11 INCH	CLASS C PATCHES, TYPE II, 11 INCH	CLASS C PATCHES, TYPE III, 11 INCH	CLASS C PATCHES, TYPE IV, 11 INCH	WELDED WIRE REINFORCEMENT
	FOOT	FOOT	SQ YD	SQ YD	SQ YD	SQ YD	SQ YD
NORTHBOUND LANE							
	6	6	4				
	6	6	4				
	10	11		12			
	30	11				37	37
	12	6		8			
	6	6	4				
	30	6			20		20
	10	11		12			
	12	6		8			
	12	11		15			
	40	6				27	27
	12	6		8			
	10	6		7			
	6	6	4				
	20	6		13			
	40	6				27	27
	30	6			20		20
	12	6		8			
	60	4				27	27
	10	6		7			
	6	11		7			
	6	11		7			
	6	11		7			
	10	6		7			
	6	6	4				
	15	6		10			
	6	6	4				
	5	6	3				
PROJECT TOTAL			43	209	64	981	1045

DRAINAGE SCHEDULE

LOCATION	LENGTH OF PATCH	WIDTH OF PATCH	FRENCH DRAINS	GEOTECHNICAL FABRIC FOR FRENCH DRAINS	PAVED SHOULDER REMOVAL	HOT-MIX ASPHALT SHOULDERS, 8"	AGGREGATE SHOULDERS, TYPE B
	FOOT	FOOT	CU YD	SQ YD	SQ YD	SQ YD	TON
INTERSTATE 57 (ALEXANDER COUNTY)							
SN 002-0025							
SOUTHBOUND DRIVING LANE							
	7	12	2	15	8	8	0
	12	12	4	23	13	13	1
	6	12	2	13	7	7	0
NORTHBOUND DRIVING LANE							
	50	12	16	91	56	56	2
	6	12	2	13	7	7	0
NORTHBOUND PASSING LANE							
	7	12	2	15	8	8	0
	7	12	2	15	8	8	0
	7	12	2	15	8	8	0
PROJECT TOTAL							
			32	198	113	113	4

FRENCH DRAINS DETAIL

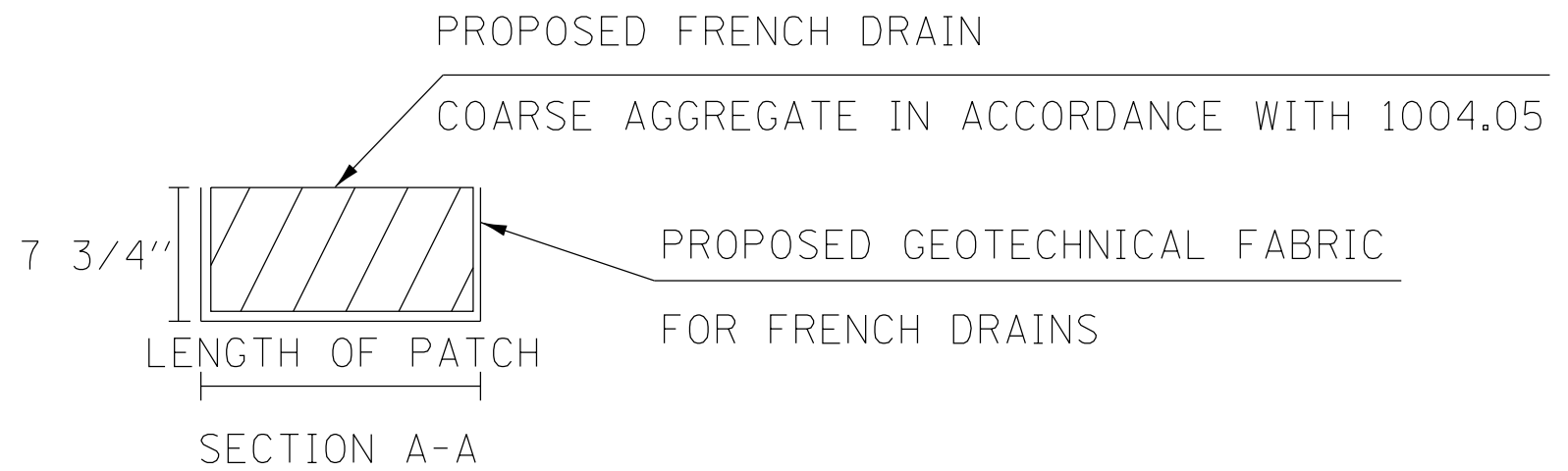
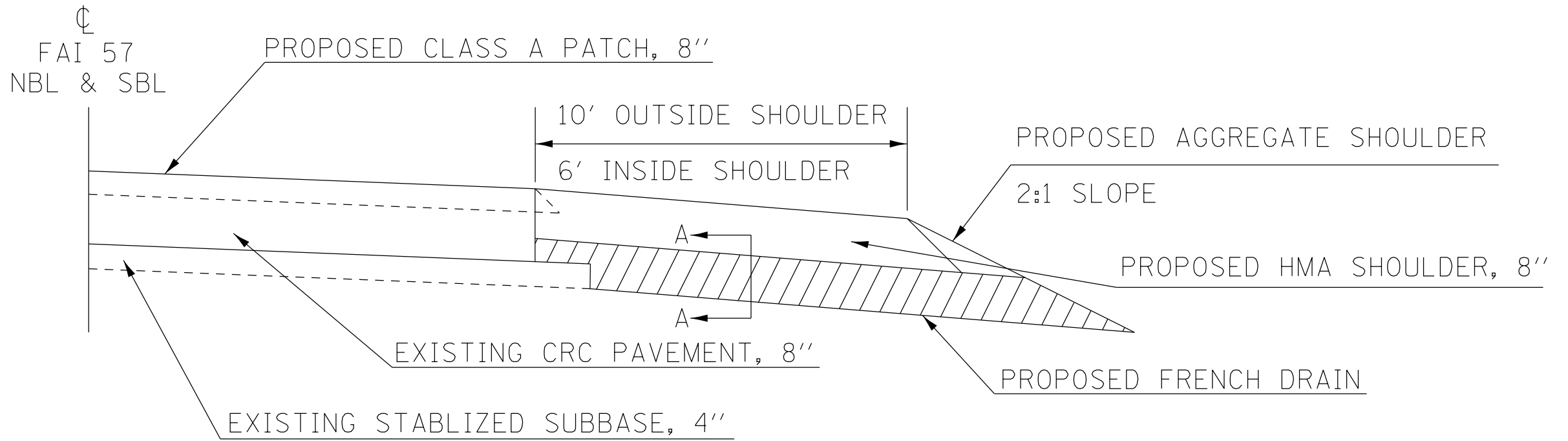

FILE NAME =	USER NAME = pritchett1	DESIGNED -	REVISED -
p:\11\084EBIDINTEG.illinois.gov\PIWIDOT\Documents\IDOT Offices\District 9\Projects\78539\Drawings\CAD\Sheets\78539.sht.dgn		DRAWN -	REVISED -
Default	PLOT SCALE = 100.0000' / in.	CHECKED -	REVISED -
	PLOT DATE = 5/6/2016	DATE -	REVISED -

**STATE OF ILLINOIS
DEPARTMENT OF TRANSPORTATION**

FRENCH DRAINS DETAIL

SCALE: SHEET OF SHEETS STA. TO STA.

F.A. RTE.	SECTION	COUNTY	TOTAL SHEETS	SHEET NO.
••	D9 CM PATCH 2017-3	VARIOUS	10	10
			CONTRACT NO. 78539	
ILLINOIS FED. AID PROJECT				