

CRACK ROUTING AND SEALING DETAIL

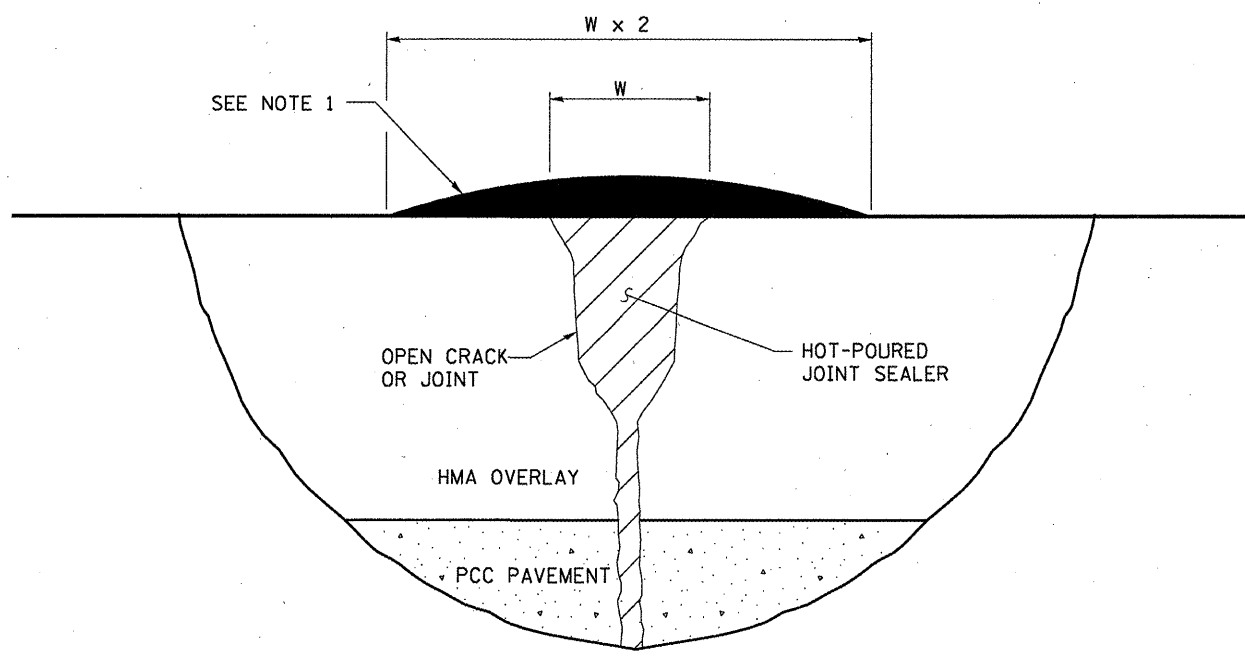

CRACK OR JOINT SEALING DETAIL

NOTE 1
 THE CRACK OR JOINT SHALL BE SLIGHTLY OVERFILLED AND IMMEDIATELY SQUEEGED TO PROVIDE A "BAND-AID" TYPE EFFECT APPROXIMATELY TWICE THE WIDTH OF THE ROUTED CRACK OR OPEN CRACK/JOINT FLUSH WITH THE PAVEMENT SURFACE AND WITH THE EDGES FEATHERED OUT.

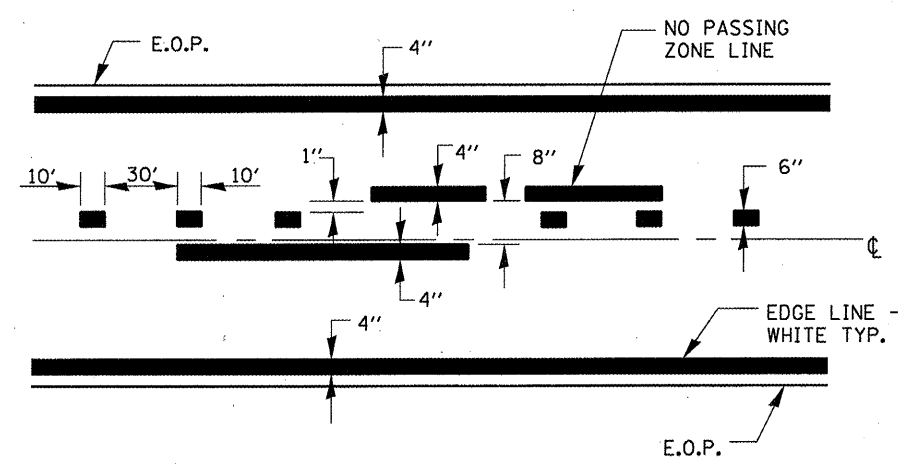

CENTERLINE & NO PASSING ZONE LINES - YELLOW

TYPICAL PAVEMENT MARKINGS

FILE NAME =	USER NAME = woodshankr1	DESIGNED - RON WOODSHANK	REVISED -
ct\pw_work\pwidot\woodshankr1\0189877\0366A34-details.dgn		DRAWN - RON WOODSHANK	REVISED -
	PLOT SCALE = 105.8938 / IN	CHECKED -	REVISED -
	PLOT DATE = Apr 26, 2010 - 09:43:02 AM	DATE -	REVISED -

STATE OF ILLINOIS
 DEPARTMENT OF TRANSPORTATION

DETAILS

F.A.P. RTE. =	SECTION	COUNTY	TOTAL SHEETS	SHEET NO.
41 & 786	D3 CRACK SEAL 2011-2	LIVINGSTON	6	6
CONTRACT NO. 66A43			ILLINOIS	
SCALE: _____	SHEET NO. 1 OF 1 SHEETS	STA. _____ TO STA. _____		