

CRACK ROUTING AND SEALING DETAIL

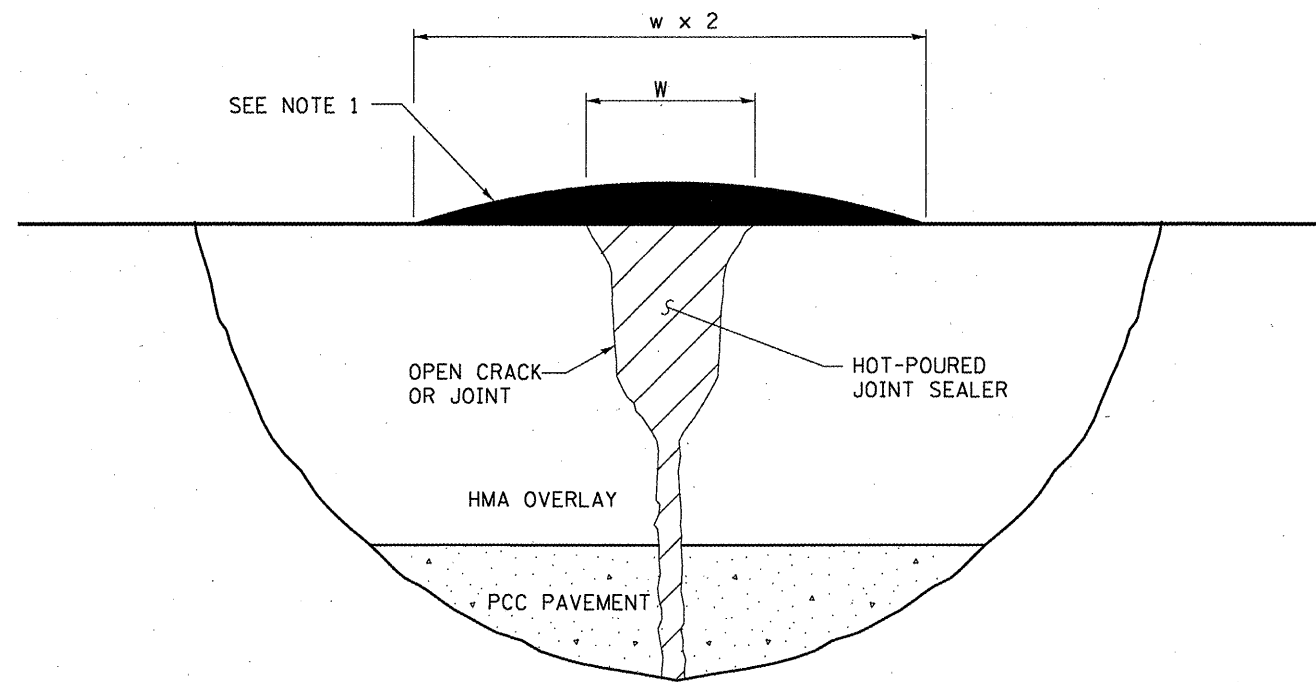

CRACK OR JOINT SEALING DETAIL

NOTE 1
 THE CRACK OR JOINT SHALL BE SLIGHTLY OVERFILLED AND IMMEDIATELY SQUEEGEED TO PROVIDE A "BAND-AID" TYPE EFFECT APPROXIMATELY TWICE THE WIDTH OF THE ROUTED CRACK OR OPEN CRACK/JOINT FLUSH WITH THE PAVEMENT SURFACE AND WITH THE EDGES FEATHERED OUT.

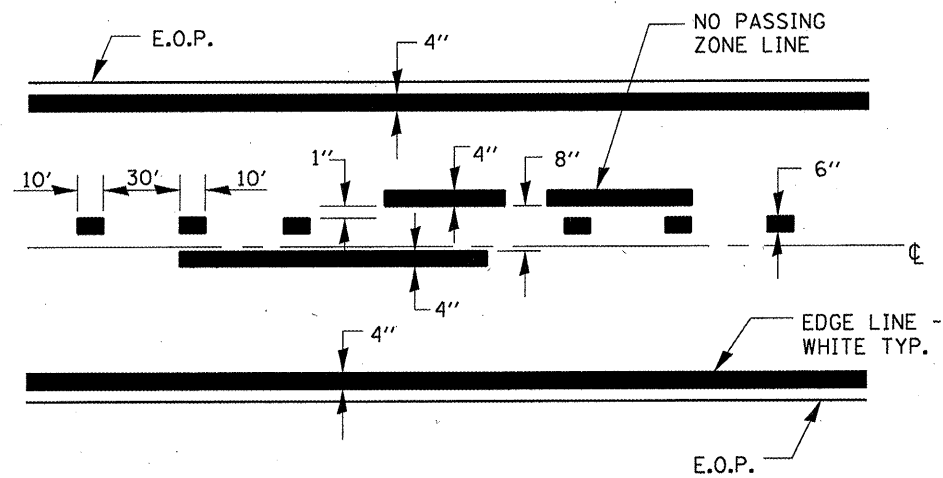

CENTERLINE & NO PASSING ZONE LINES - YELLOW

TYPICAL PAVEMENT MARKINGS

FILE NAME =	USER NAME = woodshankr1	DESIGNED - RON WOODSHANK	REVISED -
ct\pw_work\PW\DOT\WOODSHANKRL\d0189879	G366A45details.dgn	DRAWN - RON WOODSHANK	REVISED -
	PLOT SCALE = 100.0000 / IN.	CHECKED -	REVISED -
	PLOT DATE = Apr 26, 2010 - 09:47:22 AM	DATE -	REVISED -

STATE OF ILLINOIS
 DEPARTMENT OF TRANSPORTATION

DETAILS

SCALE: _____	SHEET NO. 1 OF 1 SHEETS	STA. _____ TO STA. _____
--------------	-------------------------	--------------------------

F.A.P. RTE.	SECTION	COUNTY	TOTAL SHEETS	SHEET NO.
607	D3 CRACK SEAL 2011-4	KENDALL	7	7
CONTRACT NO. 66A45			ILLINOIS FED. AID PROJECT	