

If you plan to submit a bid directly to the Department of Transportation

PREQUALIFICATION

Any contractor who desires to become pre-qualified to bid on work advertised by IDOT must submit the properly completed pre-qualification forms to the Bureau of Construction no later than 4:30 p.m. prevailing time twenty-one days prior to the letting of interest. This pre-qualification requirement applies to first time contractors, contractors renewing expired ratings, contractors maintaining continuous pre-qualification or contractors requesting revised ratings. To be eligible to bid, existing pre-qualification ratings must be effective through the date of letting.

REQUESTS FOR AUTHORIZATION TO BID

Contractors wanting to bid on items included in a particular letting must submit the properly completed "Request for Authorization to Bid/or Not For Bid Status" (BDE 124INT) and the ORIGINAL "Affidavit of Availability" (BC 57) to the proper office no later than 4:30 p.m. prevailing time, three (3) days prior to the letting date.

WHO CAN BID ?

Bids will be accepted from only those companies that request and receive written **Authorization to Bid** from IDOT's Central Bureau of Construction.

WHAT CONSTITUTES WRITTEN AUTHORIZATION TO BID?: When a prospective prime bidder submits a "Request for Authorization to Bid/or Not For Bid Status" (BDE 124INT) he/she must indicate at that time which items are being requested For Bidding purposes. Only those items requested For Bidding will be analyzed. After the request has been analyzed, the bidder will be issued an **Authorization to Bid or Not for Bid Report**, approved by the Central Bureau of Construction that indicates which items have been approved For Bidding. If **Authorization to Bid** cannot be approved, the **Authorization to Bid or Not for Bid Report** will indicate the reason for denial.

ABOUT AUTHORIZATION TO BID: Firms that have not received an authorization form within a reasonable time of complete and correct original document submittal should contact the department as to status. This is critical in the week before the letting. These documents must be received three days before the letting date. Firms unsure as to authorization status should call the Prequalification Section of the Bureau of Construction at the number listed at the end of these instructions.

ADDENDA AND REVISIONS: It is the contractor's responsibility to determine which, if any, addenda or revisions pertain to any project they may be bidding. Failure to incorporate all relevant addenda or revisions may cause the bid to be declared unacceptable.

Each addendum will be placed with the contract number. Addenda and revisions will also be placed on the Addendum/Revision Checklist and each subscription service subscriber will be notified by e-mail of each addendum and revision issued.

The Internet is the Department's primary way of doing business. The subscription server e-mails are an added courtesy the Department provides. It is suggested that bidders check IDOT's website at <http://www.dot.il.gov/desenv/delett.html> before submitting final bid information.

IDOT IS NOT RESPONSIBLE FOR ANY E-MAIL FAILURES.

Addenda Questions may be directed to the Contracts Office at (217)782-7806 or D&Econtracts@dot.il.gov

Technical Questions about downloading these files may be directed to Tim Garman (217)524-1642 or Timothy.Garman@illinois.gov.

WHAT MUST BE INCLUDED WHEN BIDS ARE SUBMITTED?: Bidders need not return the entire proposal when bids are submitted. That portion of the proposal that must be returned includes the following:

1. All documents from the Proposal Cover Sheet through the Proposal Bid Bond
2. Other special documentation and/or information that may be required by the contract special provisions

All proposal documents, including Proposal Guaranty Checks or Proposal Bid Bonds, should be stapled together to prevent loss when bids are processed by IDOT personnel.

ABOUT SUBMITTING BIDS: It is recommended that bidders deliver bids in person to insure they arrive at the proper location prior to the time specified for the receipt of bids. Any bid received at the place of letting after the time specified will not be accepted.

WHO SHOULD BE CALLED IF ASSISTANCE IS NEEDED?

Questions Regarding	Call
Prequalification and/or Authorization to Bid	217/782-3413
Preparation and submittal of bids	217/782-7806
Mailing of plans and proposals	217/782-7806

ADDENDUMS AND REVISIONS TO THE PROPOSAL FORMS

Planholders should verify that they have received and incorporated any addendum and/or revision prior to submitting their bid. Failure by the bidder to include an addendum or revision could result in a bid being rejected as irregular.

97

RETURN WITH BID

Proposal Submitted By
Name
Address
City

Letting July 30, 2010

BIDDERS NEED NOT RETURN THE ENTIRE PROPOSAL
(See instructions inside front cover)

NOTICE TO PROSPECTIVE BIDDERS

This proposal can be used for bidding purposes by only those companies that request and receive written AUTHORIZATION TO BID from IDOT's Central Bureau of Construction.
(SEE INSTRUCTIONS ON THE INSIDE OF COVER)

Notice to Bidders, Specifications, Proposal, Contract and Contract Bond



**Illinois Department
of Transportation**

Springfield, Illinois 62764

Contract No. 74296
EFFINGHAM County
Section (25-3)R,BY,BR
District 7 Construction Funds
Route FAI 57/70

PLEASE MARK THE APPROPRIATE BOX BELOW:

- A Bid Bond is included.
- A Cashier's Check or a Certified Check is included.

Prepared by

S

Checked by

(Printed by authority of the State of Illinois)

INSTRUCTIONS

ABOUT IDOT PROPOSALS: All proposals issued by IDOT are potential bidding proposals. Each proposal contains all Certifications and Affidavits, a Proposal Signature Sheet and a Proposal Bid Bond required for Prime Contractors to submit a bid after written **Authorization to Bid** has been issued by IDOT's Central Bureau of Construction. In addition, this proposal contains new statutory requirements applicable to the use of subcontractors and, in particular, includes the State Required Ethical Standards Governing Subcontractors to be signed and incorporated into all subcontracts.

WHO CAN BID?: Bids will be accepted from only those companies that request and receive written **Authorization to Bid** from IDOT's Central Bureau of Construction. To request authorization, a potential bidder must complete and submit Part B of the Request for Authorization to Bid/or Not For Bid Status form (BDE 124 INT) and submit an original Affidavit of Availability (BC 57).

WHAT CONSTITUTES WRITTEN AUTHORIZATION TO BID?: When a prospective prime bidder submits a "**Authorization to Bid or Not for Bid**" form, he/she must indicate at that time which items are being requested For Bidding purposes. Only those items requested For Bidding will be analyzed. After the request has been analyzed, the bidder will be issued a **Authorization to Bid or Not for Bid Report**, approved by the Central Bureau of Construction, that indicates which items have been approved For Bidding. If **Authorization to Bid** cannot be approved, the **Authorization to Bid or Not for Bid Report** will indicate the reason for denial. If a contractor has requested to bid but has not received a **Authorization to Bid or Not for Bid Report**, they should contact the Central Bureau of Construction in advance of the letting date.

WHAT MUST BE INCLUDED WHEN BIDS ARE SUBMITTED?: Bidders need not return the entire proposal when bids are submitted. That portion of the proposal that must be returned includes the following:

1. All documents from the Proposal Cover Sheet through the Proposal Bid Bond
2. Other special documentation and/or information that may be required by the contract special provisions

All proposal documents, including Proposal Guaranty Checks or Proposal Bid Bonds, should be stapled together to prevent loss when bids are processed by IDOT personnel.

ABOUT SUBMITTING BIDS: It is recommended that bidders deliver bids in person to insure they arrive at the proper location prior to the time specified for the receipt of bids. Any bid received at the place of letting after the time specified will not be accepted.

WHO SHOULD BE CALLED IF ASSISTANCE IS NEEDED?

Questions Regarding	Call
Prequalification and/or Authorization to Bid	217/782-3413
Preparation and submittal of bids	217/782-7806

RETURN WITH BID



PROPOSAL

TO THE DEPARTMENT OF TRANSPORTATION

1. Proposal of _____

Taxpayer Identification Number (Mandatory) _____ a

for the improvement identified and advertised for bids in the Invitation for Bids as:

**Contract No. 74296
EFFINGHAM County
Section (25-3)R,BY,BR
Route FAI 57/70
District 7 Construction Funds**

2.10 miles of interstate reconstruction upgrades from 4-lanes to 6-lanes, resurfacing, highway lighting, replacement of 2 structures and rehabilitation of 2 structures all on I-57/70 located south of Effingham (SN 025-0001, 0018, 0009 and 0010).

2. The undersigned bidder will furnish all labor, material and equipment to complete the above described project in a good and workmanlike manner as provided in the contract documents provided by the Department of Transportation. This proposal will become part of the contract and the terms and conditions contained in the contract documents shall govern performance and payments.

RETURN WITH BID

3. **ASSURANCE OF EXAMINATION AND INSPECTION/WAIVER.** The undersigned further declares that he/she has carefully examined the proposal, plans, specifications, addenda, form of contract and contract bond, and special provisions, and that he/she has inspected in detail the site of the proposed work, and that he/she has familiarized themselves with all of the local conditions affecting the contract and the detailed requirements of construction, and understands that in making this proposal he/she waives all right to plead any misunderstanding regarding the same.
4. **EXECUTION OF CONTRACT AND CONTRACT BOND.** The undersigned further agrees to execute a contract for this work and present the same to the department within fifteen (15) days after the contract has been mailed to him/her. The undersigned further agrees that he/she and his/her surety will execute and present within fifteen (15) days after the contract has been mailed to him/her contract bond satisfactory to and in the form prescribed by the Department of Transportation, in the penal sum of the full amount of the contract, guaranteeing the faithful performance of the work in accordance with the terms of the contract.
5. **PROPOSAL GUARANTY.** Accompanying this proposal is either a bid bond on the department form, executed by a corporate surety company satisfactory to the department, or a proposal guaranty check consisting of a bank cashier's check or a properly certified check for not less than 5 per cent of the amount bid or for the amount specified in the following schedule:

<u>Amount of Bid</u>		<u>Proposal Guaranty</u>	<u>Amount of Bid</u>		<u>Proposal Guaranty</u>	
Up to	\$5,000	\$150	\$2,000,000	to	\$3,000,000	\$100,000
\$5,000	to	\$10,000	\$3,000,000	to	\$5,000,000	\$150,000
\$10,000	to	\$50,000	\$5,000,000	to	\$7,500,000	\$250,000
\$50,000	to	\$100,000	\$7,500,000	to	\$10,000,000	\$400,000
\$100,000	to	\$150,000	\$10,000,000	to	\$15,000,000	\$500,000
\$150,000	to	\$250,000	\$15,000,000	to	\$20,000,000	\$600,000
\$250,000	to	\$500,000	\$20,000,000	to	\$25,000,000	\$700,000
\$500,000	to	\$1,000,000	\$25,000,000	to	\$30,000,000	\$800,000
\$1,000,000	to	\$1,500,000	\$30,000,000	to	\$35,000,000	\$900,000
\$1,500,000	to	\$2,000,000	over		\$35,000,000	\$1,000,000

Bank cashier's checks or properly certified checks accompanying proposals shall be made payable to the Treasurer, State of Illinois, when the state is awarding authority; the county treasurer, when a county is the awarding authority; or the city, village, or town treasurer, when a city, village, or town is the awarding authority.

If a combination bid is submitted, the proposal guaranties which accompany the individual proposals making up the combination will be considered as also covering the combination bid.

The amount of the proposal guaranty check is _____ \$(_____). If this proposal is accepted and the undersigned shall fail to execute a contract bond as required herein, it is hereby agreed that the amount of the proposal guaranty shall become the property of the State of Illinois, and shall be considered as payment of damages due to delay and other causes suffered by the State because of the failure to execute said contract and contract bond; otherwise, the bid bond shall become void or the proposal guaranty check shall be returned to the undersigned.

Attach Cashier's Check or Certified Check Here

In the event that one proposal guaranty check is intended to cover two or more proposals, the amount must be equal to the sum of the proposal guaranties which would be required for each individual proposal. If the guaranty check is placed in another proposal, state below where it may be found.

The proposal guaranty check will be found in the proposal for:

Item _____

Section No. _____

County _____

Mark the proposal cover sheet as to the type of proposal guaranty submitted.

RETURN WITH BID

6. **COMBINATION BIDS.** The undersigned further agrees that if awarded the contract for the sections contained in the following combination, he/she will perform the work in accordance with the requirements of each individual proposal comprising the combination bid specified in the schedule below, and that the combination bid shall be prorated against each section in proportion to the bid submitted for the same. If an error is found to exist in the gross sum bid for one or more of the individual sections included in a combination, the combination bid shall be corrected as provided in the specifications.

When a combination bid is submitted, the schedule below must be completed in each proposal comprising the combination.

If alternate bids are submitted for one or more of the sections comprising the combination, a combination bid must be submitted for each alternate.

Schedule of Combination Bids

Combination No.	Sections Included in Combination	Combination Bid	
		Dollars	Cents

7. **SCHEDULE OF PRICES.** The undersigned bidder submits herewith, in accordance with the rules and instructions, a schedule of prices for the items of work for which bids are sought. The unit prices bid are in U.S. dollars and cents, and all extensions and summations have been made. The bidder understands that the quantities appearing in the bid schedule are approximate and are provided for the purpose of obtaining a gross sum for the comparison of bids. If there is an error in the extension of the unit prices, the unit prices shall govern. Payment to the contractor awarded the contract will be made only for actual quantities of work performed and accepted or materials furnished according to the contract. The scheduled quantities of work to be done and materials to be furnished may be increased, decreased or omitted as provided elsewhere in the contract.

8. **AUTHORITY TO DO BUSINESS IN ILLINOIS.** Section 20-43 of the Illinois Procurement Code (30 ILCS 500/20-43) provides that a person (other than an individual acting as a sole proprietor) must be a legal entity authorized to do business in the State of Illinois prior to submitting the bid.

ILLINOIS DEPARTMENT OF TRANSPORTATION
 SCHEDULE OF PRICES
 CONTRACT
 NUMBER - 74296

State Job # - C-97-042-08
 PPS NBR - 7-01900-0400
 County Name - EFFINGHAM- -
 Code - 49 - -
 District - 7 - -
 Section Number - (25-3)R,BY,BR

Project Number

Route
 FAI 57/70

Item Number	Pay Item Description	Unit of Measure	Quantity	x	Unit Price	=	Total Price
A2C050G5	T-QUER BICL SWO CG 5G	EACH	200.000				
A2C070G3	T-TAXODIUM DIS CG 3G	EACH	200.000				
B2001116	T-CERCIS CAN TF 2	EACH	350.000				
B2001464	T-CORNUS MAS SF 5'	EACH	200.000				
B2006316	T-SYRG RT IS TF 2	EACH	200.000				
C2C003G3	S-AMOUPHA FRUIT CG 3G	EACH	875.000				
C2C006G3	S-ARON MEL VIK CG 3G	EACH	875.000				
C2C05724	S-RHUS AROMA 2'C	EACH	875.000				
C2C11624	S-VIBURN CARL 2'C	EACH	875.000				
C2C11736	S-VIBURN DENT 3'C	EACH	860.000				
C2002048	S-CORYLUS AMER 4'	EACH	875.000				
C20059G5	S-RHUS GLABRA 5G	EACH	875.000				
D2002972	E-PINUS STROBUS 6'	EACH	210.000				
XZ193500	BR DK MIC C OVL 2 1/4	SQ YD	591.000				
X0321778	SEISMIC RESTRAINER	EACH	28.000				

ILLINOIS DEPARTMENT OF TRANSPORTATION
 SCHEDULE OF PRICES
 CONTRACT
 NUMBER - 74296

State Job # - C-97-042-08
 PPS NBR - 7-01900-0400
 County Name - EFFINGHAM- -
 Code - 49 - -
 District - 7 - -
 Section Number - (25-3)R,BY,BR

Project Number

Route
 FAI 57/70

Item Number	Pay Item Description	Unit of Measure	Quantity	x	Unit Price	=	Total Price
X0322729	MATL TRANSFER DEVICE	TON	1,257.000				
X0322936	REMOV EX FLAR END SEC	EACH	4.000				
X0323236	TEMPORARY INLET	EACH	3.000				
X0323388	TRAFFIC COUNTER	EACH	2.000				
X0323644	PAVT MKING GROOVING	FOOT	85,343.000				
X0323988	TEMP SOIL RETEN SYSTM	SQ FT	1,638.000				
X0324865	DIAMOND GRIND BR SEC	SQ YD	4,630.000				
X0325305	STR REP CON DP = < 5	SQ FT	862.000				
X0325605	PAVT MARKING GROOVING	SQ FT	401.000				
X0358300	REM & RELAY END SECT	EACH	1.000				
X5020501	UNWAT STR EX PROT L1	EACH	1.000				
X5020502	UNWAT STR EX PROT L2	EACH	1.000				
X5020503	UNWAT STR EX PROT L3	EACH	1.000				
X5020504	UNWAT STR EX PROT L4	EACH	1.000				
X5041800	CONCRETE ANCHORS	EACH	30.000				

ILLINOIS DEPARTMENT OF TRANSPORTATION
 SCHEDULE OF PRICES
 CONTRACT
 NUMBER -

74296

State Job # - C-97-042-08
 PPS NBR - 7-01900-0400
 County Name - EFFINGHAM- -
 Code - 49 - -
 District - 7 - -
 Section Number - (25-3)R,BY,BR

Project Number

Route
 FAI 57/70

Item Number	Pay Item Description	Unit of Measure	Quantity	x	Unit Price	=	Total Price
X5060601	C&D N-LEAD PT C RS N1	L SUM	1.000				
X5060602	C&D N-LEAD PT C RS N2	L SUM	1.000				
X5080600	MECHANICAL SPLICERS	EACH	1,752.000				
X6023840	REMOVE & REL INLETS	EACH	1.000				
X6370250	C BAR VAR X-SEC 42HT	FOOT	521.000				
X7013015	TRAF CONT RD CLOSURE	L SUM	1.000				
X7800610	URETH PAVT MK LINE 4	FOOT	66,911.000				
X7800630	URETH PAVT MK LINE 6	FOOT	11,031.000				
X7800640	URETH PAVT MK LINE 8	FOOT	6,213.000				
X7800650	URETH PAVT MK LINE 12	FOOT	1,190.000				
X7800700	PREF THPL PM SHIELD	EACH	4.000				
Z0012200	CONC BR DECK SCAR 1/2	SQ YD	652.000				
Z0013798	CONSTRUCTION LAYOUT	L SUM	1.000				
Z0016002	DECK SLAB REP (FD-T2)	SQ YD	25.000				
Z0017100	DOWEL BARS	EACH	1,204.000				

ILLINOIS DEPARTMENT OF TRANSPORTATION
 SCHEDULE OF PRICES
 CONTRACT
 NUMBER -

74296

State Job # - C-97-042-08
 PPS NBR - 7-01900-0400
 County Name - EFFINGHAM- -
 Code - 49 - -
 District - 7 - -
 Section Number - (25-3)R,BY,BR

Project Number

Route
 FAI 57/70

Item Number	Pay Item Description	Unit of Measure	Quantity	x	Unit Price	=	Total Price
Z0018800	DRAINAGE SYSTEM	L SUM	1.000				
Z0030250	IMP ATTN TEMP NRD TL3	EACH	9.000				
Z0030330	IMP ATTN REL FRD TL3	EACH	1.000				
Z0030350	IMP ATTN REL NRD TL3	EACH	13.000				
Z0054505	ROCK FILL - REPLACE	TON	791.000				
Z0065730	SLOPEWALL SLUR PUMPNG	CU YD	341.000				
Z0076850	UNSOUND CONCRETE REM	SQ YD	15.800				
20100110	TREE REMOV 6-15	UNIT	866.000				
20100210	TREE REMOV OVER 15	UNIT	869.000				
20100500	TREE REMOV ACRES	ACRE	16.750				
20200100	EARTH EXCAVATION	CU YD	119,780.000				
20201200	REM & DISP UNS MATL	CU YD	705.000				
20400800	FURNISHED EXCAVATION	CU YD	91,325.000				
20700220	POROUS GRAN EMBANK	CU YD	324.000				
20700400	POROUS GRAN EMB SPEC	CU YD	1,044.000				

ILLINOIS DEPARTMENT OF TRANSPORTATION
 SCHEDULE OF PRICES
 CONTRACT
 NUMBER - 74296

State Job # - C-97-042-08
 PPS NBR - 7-01900-0400
 County Name - EFFINGHAM- -
 Code - 49 - -
 District - 7 - -
 Section Number - (25-3)R,BY,BR

Project Number

Route
 FAI 57/70

Item Number	Pay Item Description	Unit of Measure	Quantity	x	Unit Price	=	Total Price
20800150	TRENCH BACKFILL	CU YD	972.000				
21101615	TOPSOIL F & P 4	SQ YD	210,992.000				
25000200	SEEDING CL 2	ACRE	47.750				
25000300	SEEDING CL 3	ACRE	1.250				
25000350	SEEDING CL 7	ACRE	62.500				
25000400	NITROGEN FERT NUTR	POUND	4,411.000				
25000500	PHOSPHORUS FERT NUTR	POUND	4,411.000				
25000600	POTASSIUM FERT NUTR	POUND	4,411.000				
25000700	AGR GROUND LIMESTONE	TON	2.500				
25000750	MOWING	ACRE	49.000				
25100120	MULCH METHOD 2	TON	98.000				
25100630	EROSION CONTR BLANKET	SQ YD	4,536.000				
28000200	EARTH EXC - EROS CONT	CU YD	30.000				
28000305	TEMP DITCH CHECKS	FOOT	7,380.000				
28000400	PERIMETER EROS BAR	FOOT	28,188.000				

ILLINOIS DEPARTMENT OF TRANSPORTATION
 SCHEDULE OF PRICES
 CONTRACT
 NUMBER - 74296

State Job # - C-97-042-08
 PPS NBR - 7-01900-0400
 County Name - EFFINGHAM- -
 Code - 49 - -
 District - 7 - -
 Section Number - (25-3)R,BY,BR

Project Number

Route
 FAI 57/70

Item Number	Pay Item Description	Unit of Measure	Quantity	x	Unit Price	=	Total Price
28000500	INLET & PIPE PROTECT	EACH	65.000				
28001000	AGGREGATE - EROS CONT	TON	22.000				
28100105	STONE RIPRAP CL A3	SQ YD	976.000				
28100107	STONE RIPRAP CL A4	SQ YD	12,802.000				
28200200	FILTER FABRIC	SQ YD	12,802.000				
30200650	PROCESS MOD SOIL 12	SQ YD	132,106.000				
30201500	LIME	TON	1,141.100				
30201800	SLAG-MOD PORT CEMENT	TON	1,724.500				
31101100	SUB GRAN MAT B	CU YD	2,757.000				
31200500	STAB SUBBASE HMA 4	SQ YD	136,991.000				
35100700	AGG BASE CSE A 8	SQ YD	5,116.000				
40201000	AGGREGATE-TEMP ACCESS	TON	400.000				
40300100	BIT MATLS PR CT	GALLON	2,060.000				
40300300	BIT MATLS C&S CT	GALLON	5,371.000				
40300500	COVER COAT AGG	TON	102.000				

ILLINOIS DEPARTMENT OF TRANSPORTATION
 SCHEDULE OF PRICES
 CONTRACT
 NUMBER - 74296

State Job # - C-97-042-08
 PPS NBR - 7-01900-0400
 County Name - EFFINGHAM- -
 Code - 49 - -
 District - 7 - -
 Section Number - (25-3)R,BY,BR

Project Number

Route
 FAI 57/70

Item Number	Pay Item Description	Unit of Measure	Quantity	x	Unit Price	=	Total Price
40300600	SEAL COAT AGG	TON	51.000				
40600100	BIT MATLS PR CT	GALLON	1,288.000				
40600300	AGG PR CT	TON	26.300				
40600982	HMA SURF REM BUTT JT	SQ YD	588.000				
40600985	PCC SURF REM BUTT JT	SQ YD	111.000				
40600990	TEMPORARY RAMP	SQ YD	269.000				
40603550	P HMA SC "D" N105	TON	1,257.000				
40800010	BIT MATLS PR CT	GALLON	77.000				
40800030	AGG PR CT	TON	2.000				
40800050	INCIDENTAL HMA SURF	TON	349.000				
42000501	PCC PVT 10 JOINTED	SQ YD	4,594.000				
42000540	PCC PVT 12	SQ YD	31,393.000				
42001200	PAVEMENT FABRIC	SQ YD	31,415.000				
42001300	PROTECTIVE COAT	SQ YD	12,352.000				
42001420	BR APPR PVT CON (PCC)	SQ YD	284.000				

ILLINOIS DEPARTMENT OF TRANSPORTATION
 SCHEDULE OF PRICES
 CONTRACT
 NUMBER - 74296

State Job # - C-97-042-08
 PPS NBR - 7-01900-0400
 County Name - EFFINGHAM- -
 Code - 49 - -
 District - 7 - -
 Section Number - (25-3)R,BY,BR

Project Number

Route
 FAI 57/70

Item Number	Pay Item Description	Unit of Measure	Quantity	x	Unit Price	=	Total Price
42001500	PCC BR APPR SHLD PAVT	SQ YD	11.000				
42100360	CONT REINF PCC PVT 13	SQ YD	124,143.000				
42100960	PAVT REINFORCEMENT 13	SQ YD	124,143.000				
42101080	WF BM TERM JT COM SPL	EACH	4.000				
42101300	PROTECTIVE COAT	SQ YD	126,011.000				
44000100	PAVEMENT REM	SQ YD	75,297.000				
44000192	HMA REMOVAL SPL	SQ YD	4,682.000				
44000198	HMA SURF REM VAR DP	SQ YD	16,468.000				
44000500	COMB CURB GUTTER REM	FOOT	2,397.000				
44000700	APPROACH SLAB REM	SQ YD	479.000				
44004000	PAVED DITCH REMOVAL	FOOT	1,532.000				
44004250	PAVED SHLD REMOVAL	SQ YD	38,208.000				
44004400	PAVT REMOVAL SPL	SQ YD	29,495.000				
44201043	CL B PATCH T2 16	SQ YD	492.000				
44201047	CL B PATCH T3 16	SQ YD	22.000				

ILLINOIS DEPARTMENT OF TRANSPORTATION
 SCHEDULE OF PRICES
 CONTRACT
 NUMBER - 74296

State Job # - C-97-042-08
 PPS NBR - 7-01900-0400
 County Name - EFFINGHAM- -
 Code - 49 - -
 District - 7 - -
 Section Number - (25-3)R,BY,BR

Project Number

Route
 FAI 57/70

Item Number	Pay Item Description	Unit of Measure	Quantity	x	Unit Price	=	Total Price
44213200	SAW CUTS	FOOT	2,866.000				
48101500	AGGREGATE SHLDS B 6	SQ YD	7,528.000				
48102100	AGG WEDGE SHLD TYPE B	TON	81.000				
48203037	HMA SHOULDERS 10	SQ YD	214.000				
48203100	HMA SHOULDERS	TON	734.000				
50100100	REM EXIST STRUCT	EACH	2.000				
50102400	CONC REM	CU YD	211.400				
50104400	CONC HDWL REM	EACH	7.000				
50104650	SLOPE WALL REMOV	SQ YD	1,826.000				
50105220	PIPE CULVERT REMOV	FOOT	296.000				
50157300	PROTECTIVE SHIELD	SQ YD	436.000				
50200100	STRUCTURE EXCAVATION	CU YD	1,477.000				
50200300	COFFERDAM EXCAVATION	CU YD	4,172.000				
50202901	COFFERDAM LOCATION 1	EACH	1.000				
50202902	COFFERDAM LOCATION 2	EACH	1.000				

ILLINOIS DEPARTMENT OF TRANSPORTATION
 SCHEDULE OF PRICES
 CONTRACT
 NUMBER - 74296

State Job # - C-97-042-08
 PPS NBR - 7-01900-0400
 County Name - EFFINGHAM-
 Code - 49 - -
 District - 7 - -
 Section Number - (25-3)R,BY,BR

Project Number

Route
 FAI 57/70

Item Number	Pay Item Description	Unit of Measure	Quantity	x	Unit Price	=	Total Price
50202903	COFFERDAM LOCATION 3	EACH	1.000				
50202904	COFFERDAM LOCATION 4	EACH	1.000				
50300100	FLOOR DRAINS	EACH	109.000				
50300225	CONC STRUCT	CU YD	1,809.000				
50300254	RUBBED FINISH	SQ FT	737.000				
50300255	CONC SUP-STR	CU YD	2,076.900				
50300260	BR DECK GROOVING	SQ YD	5,605.000				
50300265	SEAL COAT CONC	CU YD	698.000				
50300280	CONCRETE ENCASEMENT	CU YD	70.800				
50300300	PROTECTIVE COAT	SQ YD	7,135.400				
50400745	F&E PPC BULB T-BM 72	FOOT	6,387.000				
50500405	F & E STRUCT STEEL	POUND	17,305.000				
50500715	JACK & REM EX BEARING	EACH	26.000				
50600600	CLEAN & PT STL BR N1	L SUM	1.000				
50600700	CLEAN & PT STL BR N2	L SUM	1.000				

ILLINOIS DEPARTMENT OF TRANSPORTATION
 SCHEDULE OF PRICES
 CONTRACT
 NUMBER - 74296

State Job # - C-97-042-08
 PPS NBR - 7-01900-0400
 County Name - EFFINGHAM- -
 Code - 49 - -
 District - 7 - -
 Section Number - (25-3)R,BY,BR

Project Number

Route
 FAI 57/70

Item Number	Pay Item Description	Unit of Measure	Quantity	x	Unit Price	=	Total Price
50800105	REINFORCEMENT BARS	POUND	141,080.000				
50800205	REINF BARS, EPOXY CTD	POUND	780,410.000				
50800515	BAR SPLICERS	EACH	4,015.000				
51100100	SLOPE WALL 4	SQ YD	400.000				
51201800	FUR STL PILE HP14X73	FOOT	17,566.000				
51202305	DRIVING PILES	FOOT	17,566.000				
51203800	TEST PILE ST HP14X73	EACH	12.000				
51500100	NAME PLATES	EACH	4.000				
52000110	PREF JT STRIP SEAL	FOOT	334.000				
52000320	NEOPRENE EXPAN JT 2	FOOT	232.000				
52100010	ELAST BEARING ASSY T1	EACH	26.000				
52100020	ELAST BEARING ASSY T2	EACH	28.000				
52100505	ANCHOR BOLTS 5/8	EACH	56.000				
52100520	ANCHOR BOLTS 1	EACH	36.000				
52100530	ANCHOR BOLTS 1 1/4	EACH	166.000				

ILLINOIS DEPARTMENT OF TRANSPORTATION
 SCHEDULE OF PRICES
 CONTRACT
 NUMBER - 74296

State Job # - C-97-042-08
 PPS NBR - 7-01900-0400
 County Name - EFFINGHAM- -
 Code - 49 - -
 District - 7 - -
 Section Number - (25-3)R,BY,BR

Project Number

Route
 FAI 57/70

Item Number	Pay Item Description	Unit of Measure	Quantity	x	Unit Price	=	Total Price
52100540	ANCHOR BOLTS 1 1/2	EACH	16.000				
54002020	EXPAN BOLTS 3/4	EACH	248.000				
54003000	CONC BOX CUL	CU YD	891.500				
542A0220	P CUL CL A 1 15	FOOT	121.000				
542A0229	P CUL CL A 1 24	FOOT	204.000				
542A0253	P CUL CL A 1 48	FOOT	9.000				
542A1069	P CUL CL A 2 24	FOOT	297.000				
542A1081	P CUL CL A 2 36	FOOT	27.000				
542A1093	P CUL CL A 2 48	FOOT	88.000				
542A1099	P CUL CL A 2 54	FOOT	83.000				
542A1129	P CUL CL A 2 84	FOOT	16.000				
542A1921	P CUL CL A 3 36	FOOT	40.000				
542A2809	P CUL CL A 4 84	FOOT	67.000				
542D0220	P CUL CL D 1 15	FOOT	36.000				
542D0229	P CUL CL D 1 24	FOOT	94.000				

ILLINOIS DEPARTMENT OF TRANSPORTATION
 SCHEDULE OF PRICES
 CONTRACT
 NUMBER -

74296

State Job # - C-97-042-08
 PPS NBR - 7-01900-0400
 County Name - EFFINGHAM- -
 Code - 49 - -
 District - 7 - -
 Section Number - (25-3)R,BY,BR

Project Number

Route
 FAI 57/70

Item Number	Pay Item Description	Unit of Measure	Quantity	x	Unit Price	=	Total Price
542D0241	P CUL CL D 1 36	FOOT	39.000				
54213660	PRC FLAR END SEC 15	EACH	4.000				
54213669	PRC FLAR END SEC 24	EACH	4.000				
54213681	PRC FLAR END SEC 36	EACH	2.000				
54213693	PRC FLAR END SEC 48	EACH	4.000				
54213729	PRC FLAR END SEC 84	EACH	1.000				
54215424	CIP RC END SEC 24	EACH	2.000				
54215448	CIP RC END SEC 48	EACH	2.000				
54215454	CIP RC END SEC 54	EACH	1.000				
54215484	CIP RC END SEC 84	EACH	1.000				
54215550	MET END SEC 15	EACH	3.000				
54215553	MET END SEC 18	EACH	1.000				
54215559	MET END SEC 24	EACH	6.000				
54215571	MET END SEC 36	EACH	3.000				
54217680	R C PIPE TEE 24P 24R	EACH	4.000				

ILLINOIS DEPARTMENT OF TRANSPORTATION
 SCHEDULE OF PRICES
 CONTRACT
 NUMBER - 74296

State Job # - C-97-042-08
 PPS NBR - 7-01900-0400
 County Name - EFFINGHAM- -
 Code - 49 - -
 District - 7 - -
 Section Number - (25-3)R,BY,BR

Project Number

Route
 FAI 57/70

Item Number	Pay Item Description	Unit of Measure	Quantity	x	Unit Price	=	Total Price
54248500	CONCRETE HEADWALLS	CU YD	1.700				
54248510	CONCRETE COLLAR	CU YD	9.500				
550A0070	STORM SEW CL A 1 15	FOOT	2,420.000				
550A0120	STORM SEW CL A 1 24	FOOT	231.000				
550A0410	STORM SEW CL A 2 24	FOOT	1,415.000				
55101200	STORM SEWER REM 24	FOOT	136.000				
58700300	CONCRETE SEALER	SQ FT	14,436.000				
59000200	EPOXY CRACK INJECTION	FOOT	102.000				
59100100	GEOCOMPOSITE WALL DR	SQ YD	614.000				
60100060	CONC HDWL FOR P DRAIN	EACH	103.000				
60100955	PIPE DRAINS 15	FOOT	98.000				
60100965	PIPE DRAINS 18	FOOT	94.000				
60100985	PIPE DRAINS 24	FOOT	147.000				
60101305	PIPE DRAINS 36	FOOT	27.000				
60107600	PIPE UNDERDRAINS 4	FOOT	3,353.000				

ILLINOIS DEPARTMENT OF TRANSPORTATION
 SCHEDULE OF PRICES
 CONTRACT
 NUMBER - 74296

State Job # - C-97-042-08
 PPS NBR - 7-01900-0400
 County Name - EFFINGHAM- -
 Code - 49 - -
 District - 7 - -
 Section Number - (25-3)R,BY,BR

Project Number

Route
 FAI 57/70

Item Number	Pay Item Description	Unit of Measure	Quantity	x	Unit Price	=	Total Price
60107700	PIPE UNDERDRAINS 6	FOOT	40,190.000				
60108100	PIPE UNDERDRAIN 4 SP	FOOT	76.000				
60108200	PIPE UNDERDRAIN 6 SP	FOOT	902.000				
60109580	P UNDR FOR STRUCT 4	FOOT	599.000				
60218400	MAN TA 4 DIA T1F CL	EACH	1.000				
60221100	MAN TA 5 DIA T1F CL	EACH	1.000				
60234200	INLETS TA T1F OL	EACH	1.000				
60240220	INLETS TB T3F&G	EACH	15.000				
60246605	MED INLET (604101)	EACH	4.000				
60255500	MAN ADJUST	EACH	1.000				
60262700	INLETS RECONST	EACH	1.000				
60270055	DR STR T5 W/2 T22F&G	EACH	9.000				
60500040	REMOV MANHOLES	EACH	1.000				
60500060	REMOV INLETS	EACH	5.000				
60500305	FILL INLETS	EACH	1.000				

ILLINOIS DEPARTMENT OF TRANSPORTATION
 SCHEDULE OF PRICES
 CONTRACT
 NUMBER - 74296

State Job # - C-97-042-08
 PPS NBR - 7-01900-0400
 County Name - EFFINGHAM- -
 Code - 49 - -
 District - 7 - -
 Section Number - (25-3)R,BY,BR

Project Number

Route
 FAI 57/70

Item Number	Pay Item Description	Unit of Measure	Quantity	x	Unit Price	=	Total Price
60605000	COMB CC&G TB6.24	FOOT	3,222.000				
60618324	CONC MEDIAN SURF 6 SP	SQ FT	27,820.000				
60900230	TC INLT BX 609001 SPL	EACH	1.000				
60900515	CONC THRUST BLOCKS	EACH	9.000				
63000001	SPBGR TY A 6FT POSTS	FOOT	14,250.000				
63000005	SPBGR TY B	FOOT	50.000				
63000025	SPBGR ATTACH TO STR	FOOT	36.000				
63100045	TRAF BAR TERM T2	EACH	13.000				
63100085	TRAF BAR TERM T6	EACH	14.000				
63100167	TR BAR TRM T1 SPL TAN	EACH	15.000				
63200310	GUARDRAIL REMOV	FOOT	12,267.000				
63200400	CABLE ROAD GD REM	FOOT	2,193.000				
63301210	REM RE-E SPBGR TY A	FOOT	1,479.000				
63500105	DELINEATORS	EACH	241.000				
63700275	CONC BAR 2F 42HT	FOOT	1,349.000				

ILLINOIS DEPARTMENT OF TRANSPORTATION
 SCHEDULE OF PRICES
 CONTRACT
 NUMBER -

74296

State Job # - C-97-042-08
 PPS NBR - 7-01900-0400
 County Name - EFFINGHAM- -
 Code - 49 - -
 District - 7 - -
 Section Number - (25-3)R,BY,BR

Project Number

Route
 FAI 57/70

Item Number	Pay Item Description	Unit of Measure	Quantity	x	Unit Price	=	Total Price
63700900	CONC BARRIER BASE	FOOT	1,870.000				
64200105	SHOULDER RUMBLE STRIP	FOOT	53,872.000				
66500105	WOV W FENCE 4	FOOT	2,149.000				
66700205	PERM SURV MKRS T1	EACH	48.000				
66700305	PERM SURV MKRS T2	EACH	2.000				
67000400	ENGR FIELD OFFICE A	CAL MO	27.000				
67000600	ENGR FIELD LAB	CAL MO	27.000				
67100100	MOBILIZATION	L SUM	1.000				
70100420	TRAF CONT-PROT 701411	EACH	2.000				
70100450	TRAF CONT-PROT 701201	L SUM	1.000				
70100700	TRAF CONT-PROT 701406	L SUM	1.000				
70100800	TRAF CONT-PROT 701401	L SUM	1.000				
70100825	TRAF CONT-PROT 701456	L SUM	1.000				
70101800	TRAF CONT & PROT SPL	L SUM	1.000				
70101900	TRAF CONT & PROT D1	L SUM	1.000				

ILLINOIS DEPARTMENT OF TRANSPORTATION
 SCHEDULE OF PRICES
 CONTRACT
 NUMBER -

74296

State Job # - C-97-042-08
 PPS NBR - 7-01900-0400
 County Name - EFFINGHAM- -
 Code - 49 - -
 District - 7 - -
 Section Number - (25-3)R,BY,BR

Project Number

Route
 FAI 57/70

Item Number	Pay Item Description	Unit of Measure	Quantity	x	Unit Price	=	Total Price
70103815	TR CONT SURVEILLANCE	CAL DA	50.000				
70106800	CHANGEABLE MESSAGE SN	CAL MO	25.000				
70300100	SHORT-TERM PAVT MKING	FOOT	3,993.000				
70300220	TEMP PVT MK LINE 4	FOOT	67,193.000				
70300240	TEMP PVT MK LINE 6	FOOT	11,066.000				
70300250	TEMP PVT MK LINE 8	FOOT	6,213.000				
70300260	TEMP PVT MK LINE 12	FOOT	1,190.000				
70301000	WORK ZONE PAVT MK REM	SQ FT	33,704.000				
70400100	TEMP CONC BARRIER	FOOT	26,762.500				
70400200	REL TEMP CONC BARRIER	FOOT	29,512.500				
70500100	TEMP SPBGR TY A	FOOT	395.000				
72000100	SIGN PANEL T1	SQ FT	95.000				
72000200	SIGN PANEL T2	SQ FT	48.000				
72000300	SIGN PANEL T3	SQ FT	2,945.000				
72400330	REMOV SIGN PANEL T3	SQ FT	1,213.000				

ILLINOIS DEPARTMENT OF TRANSPORTATION
 SCHEDULE OF PRICES
 CONTRACT
 NUMBER -

74296

State Job # - C-97-042-08
 PPS NBR - 7-01900-0400
 County Name - EFFINGHAM- -
 Code - 49 - -
 District - 7 - -
 Section Number - (25-3)R,BY,BR

Project Number

Route
 FAI 57/70

Item Number	Pay Item Description	Unit of Measure	Quantity	x	Unit Price	=	Total Price
72700100	STR STL SIN SUP BA	POUND	9,440.000				
72700200	TUB STL SN SUPPORT BA	POUND	307.000				
73000100	WOOD SIN SUPPORT	FOOT	130.000				
73300100	OVHD SIN STR-SPAN T1A	FOOT	286.000				
73305000	OVHD SIN STR WALKWAY	FOOT	174.000				
73400100	CONC FOUNDATION	CU YD	70.200				
73400200	DRILL SHAFT CONC FDN	CU YD	34.900				
73600100	REMOV OH SIN STR-SPAN	EACH	4.000				
73700100	REM GR-MT SIN SUPPORT	EACH	7.000				
73700200	REM CONC FDN-GR MT	EACH	7.000				
73700300	REM CONC FDN-OVHD	EACH	8.000				
78006100	PREF THPL PM LTR-SYM	SQ FT	119.200				
78100100	RAISED REFL PAVT MKR	EACH	1,091.000				
78100105	RAISED REF PVT MKR BR	EACH	29.000				
78200410	GUARDRAIL MKR TYPE A	EACH	112.000				

ILLINOIS DEPARTMENT OF TRANSPORTATION
 SCHEDULE OF PRICES
 CONTRACT
 NUMBER - 74296

State Job # - C-97-042-08
 PPS NBR - 7-01900-0400
 County Name - EFFINGHAM- -
 Code - 49 - -
 District - 7 - -
 Section Number - (25-3)R,BY,BR

Project Number

Route
 FAI 57/70

Item Number	Pay Item Description	Unit of Measure	Quantity	x	Unit Price	=	Total Price
78201000	TERMINAL MARKER - DA	EACH	15.000				
80400100	ELECT SERV INSTALL	EACH	2.000				
81021550	CON AUGERED 2 PVC	FOOT	154.000				
81021570	CON AUGERED 3 PVC	FOOT	592.000				
81100600	CON AT ST 2 GALVS	FOOT	640.000				
81100605	CON AT ST 2 PVC GALVS	FOOT	50.000				
81300530	JUN BX SS AS 12X10X6	EACH	18.000				
81603000	UD 2#8 #8G XLP USE 3/4	FOOT	3,187.000				
81603030	UD 2#4 #6G XLP USE 1	FOOT	12,046.000				
81603040	UD 2#6 #8G XLP USE 1	FOOT	21,770.000				
81702120	EC C XLP USE 1C 8	FOOT	1,145.000				
81702130	EC C XLP USE 1C 6	FOOT	1,120.000				
81800200	A CBL 2-1C4 MESS WIRE	FOOT	2,210.000				
81900200	TR & BKFIL F ELECT WK	FOOT	30,120.000				
82102400	LUM SV HOR MT 400W	EACH	116.000				

ILLINOIS DEPARTMENT OF TRANSPORTATION
 SCHEDULE OF PRICES
 CONTRACT
 NUMBER - 74296

State Job # - C-97-042-08
 PPS NBR - 7-01900-0400
 County Name - EFFINGHAM- -
 Code - 49 - -
 District - 7 - -
 Section Number - (25-3)R,BY,BR

Project Number

Route
 FAI 57/70

Item Number	Pay Item Description	Unit of Measure	Quantity	x	Unit Price	=	Total Price
82103900	LUM SV MM 250W	EACH	16.000				
82107300	UNDERPAS LUM 150W HPS	EACH	2.000				
82109105	SIGN LIGHTING (HPS)	EACH	17.000				
82500360	LT CONT BASEM 480V100	EACH	1.000				
82500380	LT CONT BASEM 480V200	EACH	1.000				
83004600	LT P A 50MH 15DA	EACH	116.000				
83057310	LT P WD 55 CL 4	EACH	16.000				
83600357	LP F M 15BC 8" X 8'	EACH	113.000				
83800650	BKWY DEV COU SS SCRNR	EACH	308.000				
84100110	REM TEMP LIGHT UNIT	EACH	16.000				
84200600	REM LT U NO SALV	EACH	9.000				
84200804	REM POLE FDN	EACH	3.000				
84500110	REMOV LIGHTING CONTR	EACH	3.000				
84500120	REMOV ELECT SERV INST	EACH	2.000				

CONTRACT NUMBER **74296**

THIS IS THE TOTAL BID **\$ _____**

NOTES:

- 1. Each PAY ITEM should have a UNIT PRICE and a TOTAL PRICE.**
- 2. The UNIT PRICE shall govern if no TOTAL PRICE is shown or if there is a discrepancy between the product of the UNIT PRICE multiplied by the QUANTITY.**
- 3. If a UNIT PRICE is omitted, the TOTAL PRICE will be divided by the QUANTITY in order to establish a UNIT PRICE.**
- 4. A bid may be declared UNACCEPTABLE if neither a unit price nor a total price is shown.**

RETURN WITH BID

STATE REQUIRED ETHICAL STANDARDS GOVERNING CONTRACT PROCUREMENT: ASSURANCES, CERTIFICATIONS AND DISCLOSURES

I. GENERAL

A. Article 50 of the Illinois Procurement Code establishes the duty of all State chief procurement officers, State purchasing officers, and their designees to maximize the value of the expenditure of public moneys in procuring goods, services, and contracts for the State of Illinois and to act in a manner that maintains the integrity and public trust of State government. In discharging this duty, they are charged by law to use all available information, reasonable efforts, and reasonable actions to protect, safeguard, and maintain the procurement process of the State of Illinois.

B. In order to comply with the provisions of Article 50 and to carry out the duty established therein, all bidders are to adhere to ethical standards established for the procurement process, and to make such assurances, disclosures and certifications required by law. Except as otherwise required in subsection III, paragraphs J-M, by execution of the Proposal Signature Sheet, the bidder indicates that each of the mandated assurances have been read and understood, that each certification is made and understood, and that each disclosure requirement has been understood and completed.

C. In addition to all other remedies provided by law, failure to comply with any assurance, failure to make any disclosure or the making of a false certification shall be grounds for the chief procurement officer to void the contract, or subcontract, and may result in the suspension or debarment of the bidder or subcontractor.

II. ASSURANCES

The assurances hereinafter made by the bidder are each a material representation of fact upon which reliance is placed should the Department enter into the contract with the bidder.

A. Conflicts of Interest

1. The Illinois Procurement Code provides in pertinent part:

Section 50-13. Conflicts of Interest.

(a) Prohibition. It is unlawful for any person holding an elective office in this State, holding a seat in the General Assembly, or appointed to or employed in any of the offices or agencies of state government and who receives compensation for such employment in excess of 60% of the salary of the Governor of the State of Illinois, or who is an officer or employee of the Capital Development Board or the Illinois Toll Highway Authority, or who is the spouse or minor child of any such person to have or acquire any contract, or any direct pecuniary interest in any contract therein, whether for stationery, printing, paper, or any services, materials, or supplies, that will be wholly or partially satisfied by the payment of funds appropriated by the General Assembly of the State of Illinois or in any contract of the Capital Development Board or the Illinois Toll Highway authority.

(b) Interests. It is unlawful for any firm, partnership, association or corporation, in which any person listed in subsection (a) is entitled to receive (i) more than 7 1/2% of the total distributable income or (ii) an amount in excess of the salary of the Governor, to have or acquire any such contract or direct pecuniary interest therein.

(c) Combined interests. It is unlawful for any firm, partnership, association, or corporation, in which any person listed in subsection (a) together with his or her spouse or minor children is entitled to receive (i) more than 15%, in the aggregate, of the total distributable income or (ii) an amount in excess of 2 times the salary of the Governor, to have or acquire any such contract or direct pecuniary interest therein.

(d) Securities. Nothing in this Section invalidates the provisions of any bond or other security previously offered or to be offered for sale or sold by or for the State of Illinois.

(e) Prior interests. This Section does not affect the validity of any contract made between the State and an officer or employee of the State or member of the General Assembly, his or her spouse, minor child or any combination of those persons if that contract was in existence before his or her election or employment as an officer, member, or employee. The contract is voidable, however, if it cannot be completed within 365 days after the officer, member, or employee takes office or is employed.

The current salary of the Governor is \$177,412.00. Sixty percent of the salary is \$106,447.20.

RETURN WITH BID

2. The bidder assures the Department that the award and execution of the contract would not cause a violation of Section 50-13, or that an effective exemption has been issued by the Board of Ethics to any individual subject to the Section 50-13 prohibitions pursuant to the provisions of Section 50-20 of the Code and Executive Order Number 3 (1998). Information concerning the exemption process is available from the Department upon request.

B. Negotiations

1. The Illinois Procurement Code provides in pertinent part:

Section 50-15. Negotiations.

(a) It is unlawful for any person employed in or on a continual contractual relationship with any of the offices or agencies of State government to participate in contract negotiations on behalf of that office or agency with any firm, partnership, association, or corporation with whom that person has a contract for future employment or is negotiating concerning possible future employment.

2. The bidder assures the Department that the award and execution of the contract would not cause a violation of Section 50-15, and that the bidder has no knowledge of any facts relevant to the kinds of acts prohibited therein.

C. Inducements

1. The Illinois Procurement Code provides:

Section 50-25. Inducement. Any person who offers or pays any money or other valuable thing to any person to induce him or her not to bid for a State contract or as recompense for not having bid on a State contract is guilty of a Class 4 felony. Any person who accepts any money or other valuable thing for not bidding for a State contract or who withholds a bid in consideration of the promise for the payment of money or other valuable thing is guilty of a Class 4 felony.

2. The bidder assures the Department that the award and execution of the contract would not cause a violation of Section 50-25, and that the bidder has no knowledge of any facts relevant to the kinds of acts prohibited therein.

D. Revolving Door Prohibition

1. The Illinois Procurement Code provides:

Section 50-30. Revolving door prohibition. Chief procurement officers, State purchasing officers, procurement compliance monitors, their designees whose principal duties are directly related to State procurement, and executive officers confirmed by the Senate are expressly prohibited for a period of 2 years after terminating an affected position from engaging in any procurement activity relating to the State agency most recently employing them in an affected position for a period of at least 6 months. The prohibition includes, but is not limited to: lobbying the procurement process; specifying; bidding; proposing bid, proposal, or contract documents; on their own behalf or on behalf of any firm, partnership, association, or corporation. This Section applies only to persons who terminate an affected position on or after January 15, 1999.

2. The bidder assures the Department that the award and execution of the contract would not cause a violation of Section 50-30, and that the bidder has no knowledge of any facts relevant to the kinds of acts prohibited therein.

E. Reporting Anticompetitive Practices

1. The Illinois Procurement Code provides:

Section 50-40. Reporting anticompetitive practices. When, for any reason, any vendor, bidder, contractor, chief procurement officer, State purchasing officer, designee, elected official, or State employee suspects collusion or other anticompetitive practice among any bidders, offerors, contractors, proposers, or employees of the State, a notice of the relevant facts shall be transmitted to the Attorney General and the chief procurement officer.

2. The bidder assures the Department that it has not failed to report any relevant facts concerning the practices addressed in Section 50-40 which may involve the contract for which the bid is submitted.

F. Confidentiality

1. The Illinois Procurement Code provides:

Section 50-45. Confidentiality. Any chief procurement officer, State purchasing officer, designee, or executive officer who willfully uses or allows the use of specifications, competitive bid documents, proprietary competitive information, proposals, contracts, or selection information to compromise the fairness or integrity of the procurement, bidding, or contract process shall be subject to immediate dismissal, regardless of the Personnel code, any contract, or any collective bargaining agreement, and may in addition be subject to criminal prosecution.

2. The bidder assures the Department that it has no knowledge of any fact relevant to the practices addressed in Section 50-45 which may involve the contract for which the bid is submitted.

RETURN WITH BID

G. Insider Information

1. The Illinois Procurement Act provides:

Section 50-50. Insider information. It is unlawful for any current or former elected or appointed State official or State employee to knowingly use confidential information available only by virtue of that office or employment for actual or anticipated gain for themselves or another person.

2. The bidder assures the Department that it has no knowledge of any facts relevant to the practices addressed in Section 50-50 which may involve the contract for which the bid is submitted.

III. CERTIFICATIONS

The certifications hereinafter made by the bidder are each a material representation of fact upon which reliance is placed should the Department enter into the contract with the bidder. Section 50-2 of the Illinois Procurement Code provides that every person that has entered into a multi-year contract and every subcontractor with a multi-year subcontract shall certify, by July 1 of each fiscal year covered by the contract after the initial fiscal year, to the responsible chief procurement officer whether it continues to satisfy the requirements of Article 50 pertaining to the eligibility for a contract award. If a contractor or subcontractor is not able to truthfully certify that it continues to meet all requirements, it shall provide with its certification a detailed explanation of the circumstances leading to the change in certification status. A contractor or subcontractor that makes a false statement material to any given certification required under Article 50 is, in addition to any other penalties or consequences prescribed by law, subject to liability under the Whistleblower Reward and Protection Act for submission of a false claim.

A. Bribery

1. The Illinois Procurement Code provides:

Section 50-5. Bribery.

(a) Prohibition. No person or business shall be awarded a contract or subcontract under this Code who:

(1) has been convicted under the laws of Illinois or any other state of bribery or attempting to bribe an officer or employee of the State of Illinois or any other state in that officer's or employee's official capacity; or

(2) has made an admission of guilt of that conduct that is a matter of record but has not been prosecuted for that conduct.

(b) Businesses. No business shall be barred from contracting with any unit of State or local government, or subcontracting under such a contract, as a result of a conviction under this Section of any employee or agent of the business if the employee or agent is no longer employed by the business and:

(1) the business has been finally adjudicated not guilty; or

(2) the business demonstrates to the governmental entity with which it seeks to contract, or which is signatory to the contract which the subcontract relates, and that entity finds that the commission of the offense was not authorized, requested, commanded, or performed by a director, officer, or high managerial agent on behalf of the business as provided in paragraph (2) of subsection (a) of Section 5-4 of the Criminal Code of 1961.

(c) Conduct on behalf of business. For purposes of this Section, when an official, agent, or employee of a business committed the bribery or attempted bribery on behalf of the business and in accordance with the direction or authorization of a responsible official of the business, the business shall be chargeable with the conduct.

(d) Certification. Every bid submitted to and contract executed by the State, and every subcontract subject to Section 20-120 of the Procurement Code shall contain a certification by the contractor or the subcontractor, respectively, that the contractor or subcontractor is not barred from being awarded a contract or subcontract under this Section and acknowledges that the chief procurement officer may declare the related contract void if any certifications required by this Section are false. A contractor who makes a false statement, material to the certification, commits a Class 3 felony.

2. The contractor or subcontractor certifies that it is not barred from being awarded a contract under Section 50.5.

B. Felons

1. The Illinois Procurement Code provides:

Section 50-10. Felons. Unless otherwise provided, no person or business convicted of a felony shall do business with the State of Illinois or any State agency, or enter into a subcontract, from the date of conviction until 5 years after the date of completion of the sentence for that felony, unless no person held responsible by a prosecutorial office for the facts upon which the conviction was based continues to have any involvement with the business.

2. Certification. Every bid submitted to and contract executed by the State and every subcontract subject to Section 20-120 of the Procurement Code shall contain a certification by the bidder or contractor or subcontractor, respectively, that the bidder, contractor, or subcontractor is not barred from being awarded a contract or subcontract under this Section and acknowledges that the chief procurement officer may declare the related contract void if any of the certifications required by this Section are false.

RETURN WITH BID

C. Debt Delinquency

1. The Illinois Procurement Code provides:

Section 50-11 and 50-12. Debt Delinquency.

The contractor or bidder or subcontractor, respectively, certifies that it, or any affiliate, is not barred from being awarded a contract or subcontract under the Procurement Code. Section 50-11 prohibits a person from entering into a contract with a State agency, or entering into a subcontract, if it knows or should know that it, or any affiliate, is delinquent in the payment of any debt to the State as defined by the Debt Collection Board. Section 50-12 prohibits a person from entering into a contract with a State agency, or entering into a subcontract, if it, or any affiliate, has failed to collect and remit Illinois Use Tax on all sales of tangible personal property into the State of Illinois in accordance with the provisions of the Illinois Use Tax Act. The bidder or contractor or subcontractor, respectively, further acknowledges that the chief procurement officer may declare the related contract void if this certification is false or if the bidder, contractor, or subcontractor, or any affiliate, is determined to be delinquent in the payment of any debt to the State during the term of the contract.

D. Prohibited Bidders, Contractors and Subcontractors

1. The Illinois Procurement Code provides:

Section 50-10.5 and 50-60(c). Prohibited bidders, contractors and subcontractors.

The bidder or contractor or subcontractor, respectively, certifies in accordance with 30 ILCS 500/50-10.5 that no officer, director, partner or other managerial agent of the contracting business has been convicted of a felony under the Sarbanes-Oxley Act of 2002 or a Class 3 or Class 2 felony under the Illinois Securities Law of 1953 or if in violation of Subsection (c) for a period of five years from the date of conviction. Every bid submitted to and contract executed by the State and every subcontract subject to Section 20-120 of the Procurement Code shall contain a certification by the bidder, contractor, or subcontractor, respectively, that the bidder, contractor, or subcontractor is not barred from being awarded a contract or subcontract under this Section and acknowledges that the chief procurement officer shall declare the related contract void if any of the certifications completed pursuant to this Section are false.

E. Section 42 of the Environmental Protection Act

The bidder or contractor or subcontractor, respectively, certifies in accordance with 30 ILCS 500/50-12 that the bidder, contractor, or subcontractor, is not barred from being awarded a contract or entering into a subcontract under this Section which prohibits the bidding on or entering into contracts with the State of Illinois or a State agency, or entering into any subcontract, that is subject to the Procurement Code by a person or business found by a court or the Pollution Control Board to have committed a willful or knowing violation of Section 42 of the Environmental Protection Act for a period of five years from the date of the order. The bidder or contractor or subcontractor, respectively, acknowledges that the chief procurement officer may declare the contract void if this certification is false.

F. Educational Loan

1. Section 3 of the Educational Loan Default Act provides:

§ 3. No State agency shall contract with an individual for goods or services if that individual is in default, as defined in Section 2 of this Act, on an educational loan. Any contract used by any State agency shall include a statement certifying that the individual is not in default on an educational loan as provided in this Section.

2. The bidder, if an individual as opposed to a corporation, partnership or other form of business organization, certifies that the bidder is not in default on an educational loan as provided in Section 3 of the Act.

G. Bid-Rigging/Bid Rotating

1. Section 33E-11 of the Criminal Code of 1961 provides:

§ 33E-11. (a) Every bid submitted to and public contract executed pursuant to such bid by the State or a unit of local government shall contain a certification by the prime contractor that the prime contractor is not barred from contracting with any unit of State or local government as a result of a violation of either Section 33E-3 or 33E-4 of this Article. The State and units of local government shall provide the appropriate forms for such certification.

- (b) A contractor who makes a false statement, material to the certification, commits a Class 3 felony.

A violation of Section 33E-3 would be represented by a conviction of the crime of bid-rigging which, in addition to Class 3 felony sentencing, provides that any person convicted of this offense or any similar offense of any state or the United States which contains the same elements as this offense shall be barred for 5 years from the date of conviction from contracting with any unit of State or local government. No corporation shall be barred from contracting with any unit of State or local government as a result of a conviction under this Section of any employee or agent of such corporation if the employee so convicted is no longer employed by the corporation and: (1) it has been finally adjudicated not guilty or (2) if it demonstrates to the governmental entity with which it seeks to contract and that entity finds that the commission of the offense was neither authorized, requested, commanded, nor performed by a director, officer or a high managerial agent in behalf of the corporation.

RETURN WITH BID

A violation of Section 33E-4 would be represented by a conviction of the crime of bid-rotating which, in addition to Class 2 felony sentencing, provides that any person convicted of this offense or any similar offense of any state or the United States which contains the same elements as this offense shall be permanently barred from contracting with any unit of State or local government. No corporation shall be barred from contracting with any unit of State or local government as a result of a conviction under this Section of any employee or agent of such corporation if the employee so convicted is no longer employed by the corporation and: (1) it has been finally adjudicated not guilty or (2) if it demonstrates to the governmental entity with which it seeks to contract and that entity finds that the commission of the offense was neither authorized, requested, commanded, nor performed by a director, officer or a high managerial agent in behalf of the corporation.

2. The bidder certifies that it is not barred from contracting with the Department by reason of a violation of either Section 33E-3 or Section 33E-4.

H. International Anti-Boycott

1. Section 5 of the International Anti-Boycott Certification Act provides:

§ 5. State contracts. Every contract entered into by the State of Illinois for the manufacture, furnishing, or purchasing of supplies, material, or equipment or for the furnishing of work, labor, or services, in an amount exceeding the threshold for small purchases according to the purchasing laws of this State or \$10,000.00, whichever is less, shall contain certification, as a material condition of the contract, by which the contractor agrees that neither the contractor nor any substantially-owned affiliated company is participating or shall participate in an international boycott in violation of the provisions of the U.S. Export Administration Act of 1979 or the regulations of the U.S. Department of Commerce promulgated under that Act.

2. The bidder makes the certification set forth in Section 5 of the Act.

I. Drug Free Workplace

1. The Illinois "Drug Free Workplace Act" applies to this contract and it is necessary to comply with the provisions of the "Act" if the contractor is a corporation, partnership, or other entity (including a sole proprietorship) which has 25 or more employees.

2. The bidder certifies that if awarded a contract in excess of \$5,000 it will provide a drug free workplace by:

(a) Publishing a statement notifying employees that the unlawful manufacture, distribution, dispensation, possession or use of a controlled substance, including cannabis, is prohibited in the contractor's workplace; specifying the actions that will be taken against employees for violations of such prohibition; and notifying the employee that, as a condition of employment on such contract, the employee shall abide by the terms of the statement, and notify the employer of any criminal drug statute conviction for a violation occurring in the workplace no later than five (5) days after such conviction.

(b) Establishing a drug free awareness program to inform employees about the dangers of drug abuse in the workplace; the contractor's policy of maintaining a drug free workplace; any available drug counseling, rehabilitation, and employee assistance programs; and the penalties that may be imposed upon employees for drug violations.

(c) Providing a copy of the statement required by subparagraph (1) to each employee engaged in the performance of the contract and to post the statement in a prominent place in the workplace.

(d) Notifying the Department within ten (10) days after receiving notice from an employee or otherwise receiving actual notice of the conviction of an employee for a violation of any criminal drug statute occurring in the workplace.

(e) Imposing or requiring, within 30 days after receiving notice from an employee of a conviction or actual notice of such a conviction, an appropriate personnel action, up to and including termination, or the satisfactory participation in a drug abuse assistance or rehabilitation program approved by a federal, state or local health, law enforcement or other appropriate agency.

(f) Assisting employees in selecting a course of action in the event drug counseling, treatment, and rehabilitation is required and indicating that a trained referral team is in place.

(g) Making a good faith effort to continue to maintain a drug free workplace through implementation of the actions and efforts stated in this certification.

RETURN WITH BID

J. Disclosure of Business Operations in Iran

Section 50-36 of the Illinois Procurement Code, 30ILCS 500/50-36 provides that each bid, offer, or proposal submitted for a State contract shall include a disclosure of whether or not the Company acting as the bidder, offeror, or proposing entity, or any of its corporate parents or subsidiaries, within the 24 months before submission of the bid, offer, or proposal had business operations that involved contracts with or provision of supplies or services to the Government of Iran, companies in which the Government of Iran has any direct or indirect equity share, consortiums or projects commissioned by the Government of Iran, or companies involved in consortiums or projects commissioned by the Government of Iran and either of the following conditions apply:

- (1) More than 10% of the Company's revenues produced in or assets located in Iran involve oil-related activities or mineral-extraction activities; less than 75% of the Company's revenues produced in or assets located in Iran involve contracts with or provision of oil-related or mineral-extraction products or services to the Government of Iran or a project or consortium created exclusively by that government; and the Company has failed to take substantial action.
- (2) The Company has, on or after August 5, 1996, made an investment of \$20 million or more, or any combination of investments of at least \$10 million each that in the aggregate equals or exceeds \$20 million in any 12-month period, which directly or significantly contributes to the enhancement of Iran's ability to develop petroleum resources of Iran.

The terms "Business operations", "Company", "Mineral-extraction activities", "Oil-related activities", "Petroleum resources", and "Substantial action" are all defined in the Code.

Failure to make the disclosure required by the Code shall cause the bid, offer or proposal to be considered not responsive. The disclosure will be considered when evaluating the bid, offer, or proposal or awarding the contract. The name of each Company disclosed as doing business or having done business in Iran will be provided to the State Comptroller.

Check the appropriate statement:

Company has no business operations in Iran to disclose.

Company has business operations in Iran as disclosed the attached document.

K. Apprenticeship and Training Certification (Does not apply to federal aid projects)

In accordance with the provisions of Section 30-22 (6) of the Illinois Procurement Code, the bidder certifies that it is a participant, either as an individual or as part of a group program, in the approved apprenticeship and training programs applicable to each type of work or craft that the bidder will perform with its own forces. The bidder further certifies for work that will be performed by subcontract that each of its subcontractors submitted for approval either (a) is, at the time of such bid, participating in an approved, applicable apprenticeship and training program; or (b) will, prior to commencement of performance of work pursuant to this contract, begin participation in an approved apprenticeship and training program applicable to the work of the subcontract. The Department, at any time before or after award, may require the production of a copy of each applicable Certificate of Registration issued by the United States Department of Labor evidencing such participation by the contractor and any or all of its subcontractors. Applicable apprenticeship and training programs are those that have been approved and registered with the United States Department of Labor. The bidder shall list in the space below, the official name of the program sponsor holding the Certificate of Registration for all of the types of work or crafts in which the bidder is a participant and that will be performed with the bidder's forces. Types of work or craft work that will be subcontracted shall be included and listed as subcontract work. The list shall also indicate any type of work or craft job category that does not have an applicable apprenticeship or training program. **The bidder is responsible for making a complete report and shall make certain that each type of work or craft job category that will be utilized on the project as reported on the Construction Employee Workforce Projection (Form BC-1256) and returned with the bid is accounted for and listed.**

The requirements of this certification and disclosure are a material part of the contract, and the contractor shall require this certification provision to be included in all approved subcontracts. In order to fulfill this requirement, it shall not be necessary that an applicable program sponsor be currently taking or that it will take applications for apprenticeship, training or employment during the performance of the work of this contract.

TO BE RETURNED WITH BID

L. Political Contributions and Registration with the State Board of Elections

Sections 20-160 and 50-37 of the Illinois Procurement Code regulate political contributions from business entities and any affiliated entities or affiliated persons bidding on or contracting with the state. Generally under Section 50-37, any business entity, and any affiliated entity or affiliated person of the business entity, whose current year contracts with all state agencies exceed an awarded value of \$50,000, are prohibited from making any contributions to any political committees established to promote the candidacy of the officeholder responsible for the awarding of the contracts or any other declared candidate for that office for the duration of the term of office of the incumbent officeholder or a period 2 years after the termination of the contract, whichever is longer. Any business entity and affiliated entities or affiliated persons whose state contracts in the current year do not exceed an awarded value of \$50,000, but whose aggregate pending bids and proposals on state contracts exceed \$50,000, either alone or in combination with contracts not exceeding \$50,000, are prohibited from making any political contributions to any political committee established to promote the candidacy of the officeholder responsible for awarding the pending contract during the period beginning on the date the invitation for bids or request for proposals is issued and ending on the day after the date of award or selection if the entity was not awarded or selected. Section 20-160 requires certification of registration of affected business entities in accordance with procedures found in Section 9-35 of The Election Code.

By submission of a bid, the contractor business entity acknowledges and agrees that it has read and understands Sections 20-160 and 50-37 of the Illinois Procurement Code, and that it makes the following certification:

The undersigned business entity certifies that it has registered as a business with the State Board of Elections and acknowledges a continuing duty to update the registration in accordance with the above referenced statutes. A copy of the certificate of registration shall be submitted with the bid. The bidder is cautioned that the Department will not award a contract without submission of the certificate of registration.

These requirements and compliance with the above referenced statutory sections are a material part of the contract, and any breach thereof shall be cause to void the contract under Section 50-60 of the Illinois Procurement Code. This provision does not apply to Federal-aid contracts.

M. Lobbyist Disclosure

Section 50-38 of the Illinois Procurement Code requires that any bidder or offeror on a State contract that hires a person required to register under the Lobbyist Registration Act to assist in obtaining a contract shall:

- (i) Disclose all costs, fees, compensation, reimbursements, and other remunerations paid or to be paid to the lobbyist related to the contract,
- (ii) Not bill or otherwise cause the State of Illinois to pay for any of the lobbyist's costs, fees, compensation, reimbursements, or other remuneration, and
- (iii) Sign a verification certifying that none of the lobbyist's costs, fees, compensation, reimbursements, or other remuneration were billed to the State.

This information, along with all supporting documents, shall be filed with the agency awarding the contract and with the Secretary of State. The chief procurement officer shall post this information, together with the contract award notice, in the online Procurement Bulletin.

Pursuant to Subsection (c) of this Section, no person or entity shall retain a person or entity to attempt to influence the outcome of a procurement decision made under the Procurement Code for compensation contingent in whole or in part upon the decision or procurement. Any person who violates this subsection is guilty of a business offense and shall be fined not more than \$10,000.

Bidder acknowledges that it is required to disclose the hiring of any person required to register pursuant to the Illinois Lobbyist Registration Act (25 ILCS 170) in connection with this contract.

Bidder has not hired any person required to register pursuant to the Illinois Lobbyist Registration Act in connection with this contract.

Or

Bidder has hired the following persons required to register pursuant to the Illinois Lobbyist Registration Act in connection with the contract:

Name and address of person: _____
All costs, fees, compensation, reimbursements and other remuneration paid to said person: _____

RETURN WITH BID

IV. DISCLOSURES

- A. The disclosures hereinafter made by the bidder are each a material representation of fact upon which reliance is placed should the Department enter into the contract with the bidder. The bidder further certifies that the Department has received the disclosure forms for each bid.

The chief procurement officer may void the bid, contract, or subcontract, respectively, if it is later determined that the bidder or subcontractor rendered a false or erroneous disclosure. A contractor or subcontractor may be suspended or debarred for violations of the Procurement Code. Furthermore, the chief procurement officer may void the contract and the surety providing the performance bond shall be responsible for completion of the contract.

B. Financial Interests and Conflicts of Interest

1. Section 50-35 of the Illinois Procurement Code provides that all bids of more than \$10,000 shall be accompanied by disclosure of the financial interests of the bidder. This disclosed information for the successful bidder, will be maintained as public information subject to release by request pursuant to the Freedom of Information Act, filed with the Procurement Policy Board, and shall be incorporated as a material term of the contract. Furthermore, pursuant to Section 5-5, the Procurement Policy Board may review a proposal, bid, or contract and issue a recommendation to void a contract or reject a proposal or bid based on any violation of the Procurement Code or the existence of a conflict of interest as provided in subsections (b) and (d) of Section 50-35.

The financial interests to be disclosed shall include ownership or distributive income share that is in excess of 5%, or an amount greater than 60% of the annual salary of the Governor, of the bidding entity or its parent entity, whichever is less, unless the contractor or bidder is a publicly traded entity subject to Federal 10K reporting, in which case it may submit its 10K disclosure in place of the prescribed disclosure. If a bidder is a privately held entity that is exempt from Federal 10K reporting, but has more than 400 shareholders, it may submit the information that Federal 10K companies are required to report, and list the names of any person or entity holding any ownership share that is in excess of 5%. The disclosure shall include the names, addresses, and dollar or proportionate share of ownership of each person making the disclosure, their instrument of ownership or beneficial relationship, and notice of any potential conflict of interest resulting from the current ownership or beneficial interest of each person making the disclosure having any of the relationships identified in Section 50-35 and on the disclosure form.

In addition, all disclosures shall indicate any other current or pending contracts, proposals, leases, or other ongoing procurement relationships the bidding entity has with any other unit of state government and shall clearly identify the unit and the contract, proposal, lease, or other relationship.

2. Disclosure Forms. Disclosure Form A is attached for use concerning the individuals meeting the above ownership or distributive share requirements. Subject individuals should be covered each by one form. In addition, a second form (Disclosure Form B) provides for the disclosure of current or pending procurement relationships with other (non-IDOT) state agencies. **The forms must be included with each bid.**

C. Disclosure Form Instructions

Form A Instructions for Financial Information & Potential Conflicts of Interest

If the bidder is a publicly traded entity subject to Federal 10K reporting, the 10K Report may be submitted to meet the requirements of Form A. If a bidder is a privately held entity that is exempt from Federal 10K reporting, but has more than 400 shareholders, it may submit the information that Federal 10K companies are required to report, and list the names of any person or entity holding any ownership share that is in excess of 5%. If a bidder is not subject to Federal 10K reporting, the bidder must determine if any individuals are required by law to complete a financial disclosure form. To do this, the bidder should answer each of the following questions. A "YES" answer indicates Form A must be completed. If the answer to each of the following questions is "NO", then the NOT APPLICABLE STATEMENT on Form A must be signed and dated by a person that is authorized to execute contracts for the bidding company. Note: These questions are for assistance only and are not required to be completed.

1. Does anyone in your organization have a direct or beneficial ownership share of greater than 5% of the bidding entity or parent entity? YES ___ NO ___
2. Does anyone in your organization have a direct or beneficial ownership share of less than 5%, but which has a value greater than \$106,447.20? YES ___ NO ___
3. Does anyone in your organization receive more than \$106,447.20 of the bidding entity's or parent entity's distributive income? (Note: Distributive income is, for these purposes, any type of distribution of profits. An annual salary is not distributive income.) YES ___ NO ___
4. Does anyone in your organization receive greater than 5% of the bidding entity's or parent entity's total distributive income, but which is less than \$106,447.20? YES ___ NO ___
(Note: Only one set of forms needs to be completed per person per bid even if a specific individual would require a yes answer to more than one question.)

A "YES" answer to any of these questions requires the completion of Form A. The bidder must determine each individual in the bidding entity or the bidding entity's parent company that would cause the questions to be answered "Yes". Each form must be signed and dated by a person that is authorized to execute contracts for your organization. **Photocopied or stamped signatures are not acceptable.** The person signing can be, but does not have to be, the person for which the form is being completed. The bidder is responsible for the accuracy of any information provided.

If the answer to each of the above questions is "NO", then the NOT APPLICABLE STATEMENT of Form A must be signed and dated by a person that is authorized to execute contracts for your company.

RETURN WITH BID

Form B: Instructions for Identifying Other Contracts & Procurement Related Information

Disclosure Form B must be completed for each bid submitted by the bidding entity. *Note: Checking the NOT APPLICABLE STATEMENT on Form A does not allow the bidder to ignore Form B. Form B must be completed, checked, and dated or the bidder may be considered nonresponsive and the bid will not be accepted.*

The Bidder shall identify, by checking Yes or No on Form B, whether it has any pending contracts (including leases), bids, proposals, or other ongoing procurement relationship with any other (non-IDOT) State of Illinois agency. If "No" is checked, the bidder only needs to complete the check box on the bottom of Form B. If "Yes" is checked, the bidder must do one of the following:

Option I: If the bidder did not submit an Affidavit of Availability to obtain authorization to bid, the bidder must list all non-IDOT State of Illinois agency pending contracts, leases, bids, proposals, and other ongoing procurement relationships. These items may be listed on Form B or on an attached sheet(s). Do not include IDOT contracts. Contracts with cities, counties, villages, etc. are not considered State of Illinois agency contracts and are not to be included. Contracts with other State of Illinois agencies such as the Department of Natural Resources or the Capital Development Board must be included. Bidders who submit Affidavits of Availability are suggested to use Option II.

Option II: If the bidder is required and has submitted an Affidavit of Availability in order to obtain authorization to bid, the bidder may write or type "See Affidavit of Availability" which indicates that the Affidavit of Availability is incorporated by reference and includes all non-IDOT State of Illinois agency pending contracts, leases, bids, proposals, and other ongoing procurement relationships. For any contracts that are not covered by the Affidavit of Availability, the bidder must identify them on Form B or on an attached sheet(s). These might be such things as leases.

**ILLINOIS DEPARTMENT
OF TRANSPORTATION**

**Form A
Financial Information &
Potential Conflicts of Interest
Disclosure**

Contractor Name		
Legal Address		
City, State, Zip		
Telephone Number	Email Address	Fax Number (if available)

Disclosure of the information contained in this Form is required by the Section 50-35 of the Illinois Procurement Code (30 ILCS 500). Vendors desiring to enter into a contract with the State of Illinois must disclose the financial information and potential conflict of interest information as specified in this Disclosure Form. This information shall become part of the publicly available contract file. This Form A must be completed for bids in excess of \$10,000, and for all open-ended contracts. **A publicly traded company may submit a 10K disclosure (or equivalent if applicable) in satisfaction of the requirements set forth in Form A. See Disclosure Form Instructions.**

DISCLOSURE OF FINANCIAL INFORMATION

1. Disclosure of Financial Information. The individual named below has an interest in the BIDDER (or its parent) in terms of ownership or distributive income share in excess of 5%, or an interest which has a value of more than \$106,447.20 (60% of the Governor's salary as of 7/1/07). **(Make copies of this form as necessary and attach a separate Disclosure Form A for each individual meeting these requirements)**

FOR INDIVIDUAL (type or print information)	
NAME:	_____
ADDRESS	_____
Type of ownership/distributable income share:	
stock _____ sole proprietorship _____ Partnership _____ other: (explain on separate sheet):	
% or \$ value of ownership/distributable income share:	_____

2. Disclosure of Potential Conflicts of Interest. Check "Yes" or "No" to indicate which, if any, of the following potential conflict of interest relationships apply. If the answer to any question is "Yes", please attach additional pages and describe.

(a) State employment, currently or in the previous 3 years, including contractual employment of services.
Yes ___ No ___

If your answer is yes, please answer each of the following questions.

1. Are you currently an officer or employee of either the Capitol Development Board or the Illinois Toll Highway Authority? Yes ___ No ___

2. Are you currently appointed to or employed by any agency of the State of Illinois? If you are currently appointed to or employed by any agency of the State of Illinois, and your annual salary exceeds \$106,447.20, (60% of the Governor's salary as of 7/1/07) provide the name the State agency for which you are employed and your annual salary. _____

RETURN WITH BID/OFFER

- 3. If you are currently appointed to or employed by any agency of the State of Illinois, and your annual salary exceeds \$106,447.20, (60% of the Governor's salary as of 7/1/07) are you entitled to receive (i) more than 7 1/2% of the total distributable income of your firm, partnership, association or corporation, or (ii) an amount in excess of the salary of the Governor? Yes ___ No ___

- 4. If you are currently appointed to or employed by any agency of the State of Illinois, and your annual salary exceeds \$106,447.20, (60% of the Governor's salary as of 7/1/07) are you and your spouse or minor children entitled to receive (i) more than 15 % in the aggregate of the total distributable income of your firm, partnership, association or corporation, or (ii) an amount in excess of 2 times the salary of the Governor? Yes ___ No ___

(b) State employment of spouse, father, mother, son, or daughter, including contractual employment services in the previous 2 years.

Yes ___ No ___

If your answer is yes, please answer each of the following questions.

- 1. Is your spouse or any minor children currently an officer or employee of the Capitol Development Board or the Illinois Toll Highway Authority? Yes ___ No ___

- 2. Is your spouse or any minor children currently appointed to or employed by any agency of the State of Illinois? If your spouse or minor children is/are currently appointed to or employed by any agency of the State of Illinois, and his/her annual salary exceeds \$106,447.20, (60 % of the Governor's salary as of 7/1/07) provide the name of your spouse and/or minor children, the name of the State agency for which he/she is employed and his/her annual salary. _____

- 3. If your spouse or any minor children is/are currently appointed to or employed by any agency of the State of Illinois, and his/her annual salary exceeds \$106,447.20, (60% of the salary of the Governor as of 7/1/07) are you entitled to receive (i) more then 71/2% of the total distributable income of your firm, partnership, association or corporation, or (ii) an amount in excess of the salary of the Governor? Yes ___ No ___

- 4. If your spouse or any minor children are currently appointed to or employed by any agency of the State of Illinois, and his/her annual salary exceeds \$106,447.20, (60% of the Governor's salary as of 7/1/07) are you and your spouse or minor children entitled to receive (i) more than 15 % in the aggregate of the total distributable income of your firm, partnership, association or corporation, or (ii) an amount in excess of 2 times the salary of the Governor? Yes ___ No ___

(c) Elective status; the holding of elective office of the State of Illinois, the government of the United States, any unit of local government authorized by the Constitution of the State of Illinois or the statutes of the State of Illinois currently or in the previous 3 years. Yes ___ No ___

(d) Relationship to anyone holding elective office currently or in the previous 2 years; spouse, father, mother, son, or daughter. Yes ___ No ___

(e) Appointive office; the holding of any appointive government office of the State of Illinois, the United States of America, or any unit of local government authorized by the Constitution of the State of Illinois or the statutes of the State of Illinois, which office entitles the holder to compensation in excess of the expenses incurred in the discharge of that office currently or in the previous 3 years. Yes ___ No ___

(f) Relationship to anyone holding appointive office currently or in the previous 2 years; spouse, father, mother, son, or daughter. Yes ___ No ___

(g) Employment, currently or in the previous 3 years, as or by any registered lobbyist of the State government. Yes ___ No ___

RETURN WITH BID/OFFER

(h) Relationship to anyone who is or was a registered lobbyist in the previous 2 years; spouse, father, mother, son, or daughter. Yes ___ No ___

(i) Compensated employment, currently or in the previous 3 years, by any registered election or reelection committee registered with the Secretary of State or any county clerk of the State of Illinois, or any political action committee registered with either the Secretary of State or the Federal Board of Elections. Yes ___ No ___

(j) Relationship to anyone; spouse, father, mother, son, or daughter; who was a compensated employee in the last 2 years by any registered election or re-election committee registered with the Secretary of State or any county clerk of the State of Illinois, or any political action committee registered with either the Secretary of State or the Federal Board of Elections. Yes ___ No ___

2. Communication Disclosure.

Disclose the name and address of each lobbyist and other agent of the bidder or offeror who is not identified in Section 2 of this form, who is has communicated, is communicating, or may communicate with any State officer or employee concerning the bid or offer. This disclosure is a continuing obligation and must be promptly supplemented for accuracy throughout the process and throughout the term of the contract. If no person is identified, enter "None" on the line below:

Name and address of person(s): _____

4. Debarment Disclosure. For each of the persons identified under Sections 2 and 3 of this form, disclose whether any of the following has occurred within the previous 10 years: debarment from contracting with any governmental entity; professional licensure discipline; bankruptcies; adverse civil judgments and administrative findings; and criminal felony convictions. This disclosure is a continuing obligation and must be promptly supplemented for accuracy throughout the procurement process and term of the contract. If no person is identified, enter "None" on the line below:

Name of person(s): _____

Nature of disclosure: _____

APPLICABLE STATEMENT

This Disclosure Form A is submitted on behalf of the INDIVIDUAL named on previous page. Under penalty of perjury, I certify the contents of this disclosure to be true and accurate to the best of my knowledge.

Completed by: _____ Date _____
Signature of Individual or Authorized Representative

NOT APPLICABLE STATEMENT

Under penalty of perjury, I have determined that no individuals associated with this organization meet the criteria that would require the completion of this Form A.

This Disclosure Form A is submitted on behalf of the CONTRACTOR listed on the previous page.

_____ Date _____
Signature of Authorized Representative

The bidder has a continuing obligation to supplement these disclosures under Sec. 50-35 of the Procurement Code.

RETURN WITH BID

**ILLINOIS DEPARTMENT
OF TRANSPORTATION**

**Form B
Other Contracts &
Procurement Related Information
Disclosure**

Contractor Name		
Legal Address		
City, State, Zip		
Telephone Number	Email Address	Fax Number (if available)

Disclosure of the information contained in this Form is required by the Section 50-35 of the Illinois Procurement Act (30 ILCS 500). This information shall become part of the publicly available contract file. This Form B must be completed for bids in excess of \$10,000, and for all open-ended contracts.

DISCLOSURE OF OTHER CONTRACTS AND PROCUREMENT RELATED INFORMATION

1. Identifying Other Contracts & Procurement Related Information. The BIDDER shall identify whether it has any pending contracts (including leases), bids, proposals, or other ongoing procurement relationship with any other State of Illinois agency: Yes ___ No ___

If **“No” is checked**, the bidder only needs to complete the signature box on the bottom of this page.

2. If “Yes” is checked. Identify each such relationship by showing State of Illinois agency name and other descriptive information such as bid or project number (attach additional pages as necessary). SEE DISCLOSURE FORM INSTRUCTIONS:

THE FOLLOWING STATEMENT MUST BE CHECKED

<input type="checkbox"/>	_____	_____
	Signature of Authorized Representative	Date

RETURN WITH BID

SPECIAL NOTICE TO CONTRACTORS

The following requirements of the Illinois Department of Human Rights' Rules and Regulations are applicable to bidders on all construction contracts advertised by the Illinois Department of Transportation:

CONSTRUCTION EMPLOYEE UTILIZATION PROJECTION

- (a) All bidders on construction contracts shall complete and submit, along with and as part of their bids, a Bidder's Employee Utilization Form (Form BC-1256) setting forth a projection and breakdown of the total workforce intended to be hired and/or allocated to such contract work by the bidder including a projection of minority and female employee utilization in all job classifications on the contract project.
- (b) The Department of Transportation shall review the Employee Utilization Form, and workforce projections contained therein, of the contract awardee to determine if such projections reflect an underutilization of minority persons and/or women in any job classification in accordance with the Equal Employment Opportunity Clause and Section 7.2 of the Illinois Department of Human Rights' Rules and Regulations for Public Contracts adopted as amended on September 17, 1980. If it is determined that the contract awardee's projections reflect an underutilization of minority persons and/or women in any job classification, it shall be advised in writing of the manner in which it is underutilizing and such awardee shall be considered to be in breach of the contract unless, prior to commencement of work on the contract project, it submits revised satisfactory projections or an acceptable written affirmative action plan to correct such underutilization including a specific timetable geared to the completion stages of the contract.
- (c) The Department of Transportation shall provide to the Department of Human Rights a copy of the contract awardee's Employee Utilization Form, a copy of any required written affirmative action plan, and any written correspondence related thereto. The Department of Human Rights may review and revise any action taken by the Department of Transportation with respect to these requirements.

RETURN WITH BID

**Contract No. 74296
EFFINGHAM County
Section (25-3)R,BY,BR
Route FAI 57/70
District 7 Construction Funds**

PART II. WORKFORCE PROJECTION - continued

- B. Included in "Total Employees" under Table A is the total number of **new hires** that would be employed in the event the undersigned bidder is awarded this contract.

The undersigned bidder projects that: (number) _____ new hires would be recruited from the area in which the contract project is located; and/or (number) _____ new hires would be recruited from the area in which the bidder's principal office or base of operation is located.

- C. Included in "Total Employees" under Table A is a projection of numbers of persons to be employed directly by the undersigned bidder as well as a projection of numbers of persons to be employed by subcontractors.

The undersigned bidder estimates that (number) _____ persons will be directly employed by the prime contractor and that (number) _____ persons will be employed by subcontractors.

PART III. AFFIRMATIVE ACTION PLAN

- A. The undersigned bidder understands and agrees that in the event the foregoing minority and female employee utilization projection included under **PART II** is determined to be an underutilization of minority persons or women in any job category, and in the event that the undersigned bidder is awarded this contract, he/she will, prior to commencement of work, develop and submit a written Affirmative Action Plan including a specific timetable (geared to the completion stages of the contract) whereby deficiencies in minority and/or female employee utilization are corrected. Such Affirmative Action Plan will be subject to approval by the contracting agency and the **Department of Human Rights**.
- B. The undersigned bidder understands and agrees that the minority and female employee utilization projection submitted herein, and the goals and timetable included under an Affirmative Action Plan if required, are deemed to be part of the contract specifications.

Company _____ Telephone Number _____

Address _____

NOTICE REGARDING SIGNATURE

The Bidder's signature on the Proposal Signature Sheet will constitute the signing of this form. The following signature block needs to be completed if revisions are required.

Signature: _____ Title: _____ Date: _____

- Instructions: All tables must include subcontractor personnel in addition to prime contractor personnel.
- Table A - Include both the number of employees that would be hired to perform the contract work and the total number currently employed (Table B) that will be allocated to contract work, and include all apprentices and on-the-job trainees. The "Total Employees" column should include all employees including all minorities, apprentices and on-the-job trainees to be employed on the contract work.
 - Table B - Include all employees currently employed that will be allocated to the contract work including any apprentices and on-the-job trainees currently employed.
 - Table C - Indicate the racial breakdown of the total apprentices and on-the-job trainees shown in Table A.

RETURN WITH BID

**Contract No. 74296
EFFINGHAM County
Section (25-3)R,BY,BR
Route FAI 57/70
District 7 Construction Funds**

PROPOSAL SIGNATURE SHEET

The undersigned bidder hereby makes and submits this bid on the subject Proposal, thereby assuring the Department that all requirements of the Invitation for Bids and rules of the Department have been met, that there is no misunderstanding of the requirements of paragraph 3 of this Proposal, and that the contract will be executed in accordance with the rules of the Department if an award is made on this bid.

(IF AN INDIVIDUAL)

Firm Name _____

Signature of Owner _____

Business Address _____

(IF A CO-PARTNERSHIP)

Firm Name _____

By _____

Business Address _____

Name and Address of All Members of the Firm:

(IF A CORPORATION)

Corporate Name _____

By _____

Signature of Authorized Representative _____

Typed or printed name and title of Authorized Representative _____

Attest _____

Signature _____

(IF A JOINT VENTURE, USE THIS SECTION FOR THE MANAGING PARTY AND THE SECOND PARTY SHOULD SIGN BELOW)

Business Address _____

(IF A JOINT VENTURE)

Corporate Name _____

By _____

Signature of Authorized Representative _____

Typed or printed name and title of Authorized Representative _____

Attest _____

Signature _____

Business Address _____

If more than two parties are in the joint venture, please attach an additional signature sheet.



Return with Bid

Division of Highways
Proposal Bid Bond
(Effective November 1, 1992)

Item No.
Letting Date

KNOW ALL MEN BY THESE PRESENTS, That We

as PRINCIPAL, and

as SURETY, are held jointly, severally and firmly bound unto the STATE OF ILLINOIS in the penal sum of 5 percent of the total bid price, or for the amount specified in Article 102.09 of the "Standard Specifications for Road and Bridge Construction" in effect on the date of invitation for bids, whichever is the lesser sum, well and truly to be paid unto said STATE OF ILLINOIS, for the payment of which we bind ourselves, our heirs, executors, administrators, successors and assigns.

THE CONDITION OF THE FOREGOING OBLIGATION IS SUCH, that whereas, the PRINCIPAL has submitted a bid proposal to the STATE OF ILLINOIS, acting through the Department of Transportation, for the improvement designated by the Transportation Bulletin Item Number and Letting Date indicated above.

NOW, THEREFORE, if the Department shall accept the bid proposal of the PRINCIPAL; and if the PRINCIPAL shall, within the time and as specified in the bidding and contract documents, submit a DBE Utilization Plan that is accepted and approved by the Department; and if, after award by the Department, the PRINCIPAL shall enter into a contract in accordance with the terms of the bidding and contract documents including evidence of the required insurance coverages and providing such bond as specified with good and sufficient surety for the faithful performance of such contract and for the prompt payment of labor and material furnished in the prosecution thereof; or if, in the event of the failure of the PRINCIPAL to make the required DBE submission or to enter into such contract and to give the specified bond, the PRINCIPAL pays to the Department the difference not to exceed the penalty hereof between the amount specified in the bid proposal and such larger amount for which the Department may contract with another party to perform the work covered by said bid proposal, then this obligation shall be null and void, otherwise, it shall remain in full force and effect.

IN THE EVENT the Department determines the PRINCIPAL has failed to comply with any requirement as set forth in the preceding paragraph, then Surety shall pay the penal sum to the Department within fifteen (15) days of written demand therefor. If Surety does not make full payment within such period of time, the Department may bring an action to collect the amount owed. Surety is liable to the Department for all its expenses, including attorney's fees, incurred in any litigation in which it prevails either in whole or in part.

In TESTIMONY WHEREOF, the said PRINCIPAL and the said SURETY have caused this instrument to be signed by their respective officers this day of A.D.,

PRINCIPAL SURETY
(Company Name) (Company Name)
By (Signature & Title) By: (Signature of Attorney-in-Fact)

Notary Certification for Principal and Surety

STATE OF ILLINOIS,
County of
I, , a Notary Public in and for said County, do hereby certify that
and
(Insert names of individuals signing on behalf of PRINCIPAL & SURETY)

who are each personally known to me to be the same persons whose names are subscribed to the foregoing instrument on behalf of PRINCIPAL and SURETY, appeared before me this day in person and acknowledged respectively, that they signed and delivered said instrument as their free and voluntary act for the uses and purposes therein set forth.

Given under my hand and notarial seal this day of A.D.
My commission expires
Notary Public

In lieu of completing the above section of the Proposal Bid Form, the Principal may file an Electronic Bid Bond. By signing the proposal and marking the check box next to the Signature and Title line below, the Principal is ensuring the identified electronic bid bond has been executed and the Principal and Surety are firmly bound unto the State of Illinois under the conditions of the bid bond as shown above.

Electronic Bid Bond ID# Company / Bidder Name Signature and Title

(1) Policy

It is public policy that disadvantageded businesses as defined in 49 CFR Part 26 and the Special Provision shall have the maximum opportunity to participate in the performance of contracts financed in whole or in part with Federal or State funds. Consequently the requirements of 49 CFR Part 26 apply to this contract.

(2) Obligation

The contractor agrees to ensure that disadvantageded businesses as defined in 49 CFR Part 26 and the Special Provision have the maximum opportunity to participate in the performance of contracts or subcontracts financed in whole or in part with Federal or State funds. The contractor shall take all necessary and reasonable steps in accordance with 49 CFR Part 26 and the Special Provision to ensure that said businesses have the maximum opportunity to compete for and perform under this contract. The contractor shall not discriminate on the basis of race, color, national origin or sex in the award and performance of contracts.

(3) Project and Bid Identification

Complete the following information concerning the project and bid:

Route _____	Total Bid _____
Section _____	Contract DBE Goal _____
Project _____	(Percent) (Dollar Amount)
County _____	
Letting Date _____	
Contract No. _____	
Letting Item No. _____	

(4) Assurance

I, acting in my capacity as an officer of the undersigned bidder (or bidders if a joint venture), hereby assure the Department that on this project my company : (check one)

Meets or exceeds contract award goals and has provided documented participation as follows:
Disadvantaged Business Participation _____ percent

Attached are the signed participation statements, forms SBE 2025, required by the Special Provision evidencing availability and use of each business participating in this plan and assuring that each business will perform a commercially useful function in the work of the contract.

Failed to meet contract award goals and has included good faith effort documentation to meet the goals and that my company has provided participation as follows:
Disadvantaged Business Participation _____ percent

The contract goals should be accordingly modified or waived. Attached is all information required by the Special Provision in support of this request including good faith effort. Also attached are the signed participation statements, forms SBE 2025, required by the Special Provision evidencing availability and use of each business participating in this plan and assuring that each business will perform a commercially useful function in the work of the contract.

Company

By _____

Title _____

Date _____

The "as read" Low Bidder is required to comply with the Special Provision.

Submit only one utilization plan for each project. The utilization plan shall be submitted in accordance with the special provision.

Bureau of Small Business Enterprises **Local Let Projects**
2300 South Dirksen Parkway Submit forms to the
Springfield, Illinois 62764 Local Agency

The Department of Transportation is requesting disclosure of information that is necessary to accomplish the purpose as outlined under State and Federal law. Disclosure of this information is **REQUIRED**. Failure to provide any information will result in the contract not being awarded. This form has been approved by the State Forms Manager Center.



Illinois Department of Transportation

DBE Participation Statement

Subcontractor Registration _____

Letting _____

Participation Statement

Item No. _____

(1) Instructions

Contract _____

This form must be completed for each disadvantaged business participating in the Utilization Plan. This form shall be submitted in accordance with the special provision and will be attached to the Utilization Plan form.. If additional space is needed complete an additional form for the firm.

(2) Work

Pay Item No.	Description	Quantity	Unit Price	Total
Total				

(3) Partial Payment Items

For any of the above items which are partial pay items, specifically describe the work and subcontract dollar amount:

(4) Commitment

The undersigned certify that the information included herein is true and correct, and that the DBE firm listed below has agreed to perform a commercially useful function in the work of the contract item(s) listed above and to execute a contract with the prime contractor. The undersigned further understand that no changes to this statement may be made without prior approval from the Department’s Bureau of Small Business Enterprises and that complete and accurate information regarding actual work performed on this project and the payment therefore must be provided to the Department.

Signature for Prime Contractor

Signature for DBE Firm

Title _____

Date _____

Contact _____

Phone _____

Firm Name _____

Address _____

City/State/Zip _____

Title _____

Date _____

Contact _____

Phone _____

Firm Name _____

Address _____

City/State/Zi _____

E _____

WC _____

The Department of Transportation is requesting disclosure of information that is necessary to accomplish the statutory purpose as outlined under the state and federal law. Disclosure of this information is **REQUIRED**. Failure to provide any information will result in the contract not being awarded. This form has been approved by the State Forms Management Center.

PROPOSAL ENVELOPE



PROPOSALS

for construction work advertised for bids by the
Illinois Department of Transportation

Item No.	Item No.	Item No.

Submitted By:

Name:
Address:
Phone No.

Bidders should use an IDOT proposal envelope or affix this form to the front of a 10" x 13" envelope for the submittal of bids. If proposals are mailed, they should be enclosed in a second or outer envelope addressed to:

Engineer of Design and Environment - Room 326
Illinois Department of Transportation
2300 South Dirksen Parkway
Springfield, Illinois 62764

NOTICE

Individual bids, including Bid Bond and/or supplemental information if required, should be securely stapled.

CONTRACTOR OFFICE COPY OF CONTRACT SPECIFICATIONS

NOTICE

None of the following material needs to be returned with the bid package unless the special provisions require documentation and/or other information to be submitted.

Contract No. 74296
EFFINGHAM County
Section (25-3)R,BY,BR
Route FAI 57/70
District 7 Construction Funds



Illinois Department of Transportation

SUBCONTRACTOR DOCUMENTATION

P.A. 96-0795, effective July 1, 2010, enacted substantial changes to the provisions of the Illinois Procurement Code (30 ILCS 500). Among the changes are provisions affecting subcontractors. The Contractor awarded this contract will be required as a material condition of the contract to implement and enforce the contract requirements applicable to subcontractors approved in accordance with article 108.01 of the Standard Specifications for Road and Bridge Construction.

If the Contractor seeks approval of subcontractors to perform a portion of the work, and approval is granted by the Department, the Contractor shall provide a copy of the subcontract to the Chief Procurement Officer within 20 calendar days after execution of the subcontract.

The subcontract shall contain the certifications required to be made by subcontractors pursuant to Article 50 of the Illinois Procurement Code. This Notice to Bidders includes a document incorporating all required subcontractor certifications and disclosures for use by the Contractor in compliance with this mandate. The document is entitled State Required Ethical Standards Governing Subcontractors.

STATE ETHICAL STANDARDS
GOVERNING SUBCONTRACTORS

Article 50 of the Illinois Procurement Code establishes the duty of all State chief procurement officers, State purchasing officers, and their designees to maximize the value of the expenditure of public moneys in procuring goods, services, and contracts for the State of Illinois and to act in a manner that maintains the integrity and public trust of State government. In discharging this duty, they are charged by law to use all available information, reasonable efforts, and reasonable actions to protect, safeguard, and maintain the procurement process of the State of Illinois.

The certifications hereinafter made by the subcontractor are each a material representation of fact upon which reliance is placed should the Department approve the subcontractor. The chief procurement officer may terminate or void the subcontract approval if it is later determined that the bidder or subcontractor rendered a false or erroneous certification.

Section 50-2 of the Illinois Procurement Code provides that every person that has entered into a multi-year contract and every subcontractor with a multi-year subcontract shall certify, by July 1 of each fiscal year covered by the contract after the initial fiscal year, to the responsible chief procurement officer whether it continues to satisfy the requirements of Article 50 pertaining to the eligibility for a contract award. If a contractor or subcontractor is not able to truthfully certify that it continues to meet all requirements, it shall provide with its certification a detailed explanation of the circumstances leading to the change in certification status. A contractor or subcontractor that makes a false statement material to any given certification required under Article 50 is, in addition to any other penalties or consequences prescribed by law, subject to liability under the Whistleblower Reward and Protection Act for submission of a false claim.

A. Bribery

1. The Illinois Procurement Code provides:

Section 50-5. Bribery.

(a) Prohibition. No person or business shall be awarded a contract or subcontract under this Code who:

- (1) has been convicted under the laws of Illinois or any other state of bribery or attempting to bribe an officer or employee of the State of Illinois or any other state in that officer's or employee's official capacity; or
- (2) has made an admission of guilt of that conduct that is a matter of record but has not been prosecuted for that conduct.

(b) Businesses. No business shall be barred from contracting with any unit of State or local government, or subcontracting under such a contract, as a result of a conviction under this Section of any employee or agent of the business if the employee or agent is no longer employed by the business and:

- (1) the business has been finally adjudicated not guilty; or
- (2) the business demonstrates to the governmental entity with which it seeks to contract, or which is signatory to the contract to which the subcontract relates, and that entity finds that the commission of the offense was not authorized, requested, commanded, or performed by a director, officer, or high managerial agent on behalf of the business as provided in paragraph (2) of subsection (a) of Section 5-4 of the Criminal Code of 1961.

(c) Conduct on behalf of business. For purposes of this Section, when an official, agent, or employee of a business committed the bribery or attempted bribery on behalf of the business and in accordance with the direction or authorization of a responsible official of the business, the business shall be chargeable with the conduct.

(d) Certification. Every bid submitted to and contract executed by the State, and every subcontract subject to Section 20-120 of the Procurement Code shall contain a certification by the contractor or the subcontractor, respectively, that the contractor or subcontractor is not barred from being awarded a contract or subcontract under this Section and acknowledges that the chief procurement officer may declare the related contract void if any certifications required by this Section are false. A contractor who makes a false statement, material to the certification, commits a Class 3 felony.

2. The contractor or subcontractor certifies that it is not barred from being awarded a contract under Section 50.5.

B. Felons

1. The Illinois Procurement Code provides:

Section 50-10. Felons. Unless otherwise provided, no person or business convicted of a felony shall do business with the State of Illinois or any State agency, or enter into a subcontract, from the date of conviction until 5 years after the date of completion of the sentence for that felony, unless no person held responsible by a prosecutorial office for the facts upon which the conviction was based continues to have any involvement with the business.

2. Certification. Every bid submitted to and contract executed by the State and every subcontract subject to Section 20-120 of the Procurement Code shall contain a certification by the bidder or contractor or subcontractor, respectively, that the bidder, contractor, or subcontractor is not barred from being awarded a contract or subcontract under this Section and acknowledges that the chief procurement officer may declare the related contract void if any of the certifications required by this Section are false.

C. Debt Delinquency

1. The Illinois Procurement Code provides:

Section 50-11 and 50-12. Debt Delinquency.

The contractor or bidder or subcontractor, respectively, certifies that it, or any affiliate, is not barred from being awarded a contract or subcontract under the Procurement Code. Section 50-11 prohibits a person from entering into a contract with a State agency, or entering into a subcontract, if it knows or should know that it, or any affiliate, is delinquent in the payment of any debt to the State as defined by the Debt Collection Board. Section 50-12 prohibits a person from entering into a contract with a State agency, or entering into a subcontract, if it, or any affiliate, has failed to collect and remit Illinois Use Tax on all sales of tangible personal property into the State of Illinois in accordance with the provisions of the Illinois Use Tax Act. The bidder or contractor or subcontractor, respectively, further acknowledges that the chief procurement officer may declare the related contract void if this certification is false or if the bidder, contractor, or subcontractor, or any affiliate, is determined to be delinquent in the payment of any debt to the State during the term of the contract.

D. Prohibited Bidders, Contractors and Subcontractors

1. The Illinois Procurement Code provides:

Section 50-10.5 and 50-60(c). Prohibited bidders, contractors and subcontractors.

The bidder or contractor or subcontractor, respectively, certifies in accordance with 30 ILCS 500/50-10.5 that no officer, director, partner or other managerial agent of the contracting business has been convicted of a felony under the Sarbanes-Oxley Act of 2002 or a Class 3 or Class 2 felony under the Illinois Securities Law of 1953 or if in violation of Subsection (c) for a period of five years from the date of conviction.. Every bid submitted to and contract executed by the State and every subcontract subject to Section 20-120 of the Procurement Code shall contain a certification by the bidder, contractor, or subcontractor, respectively, that the bidder, contractor, or subcontractor is not barred from being awarded a contract or subcontract under this Section and acknowledges that the chief procurement officer shall declare the related contract void if any of the certifications completed pursuant to this Section are false.

E. Section 42 of the Environmental Protection Act

The bidder or contractor or subcontractor, respectively, certifies in accordance with 30 ILCS 500/50-12 that the bidder, contractor, or subcontractor, is not barred from being awarded a contract or entering into a subcontract under this Section which prohibits the bidding on or entering into contracts with the State of Illinois or a State agency, or entering into any subcontract, that is subject to the Procurement Code by a person or business found by a court or the Pollution Control Board to have committed a willful or knowing violation of Section 42 of the Environmental Protection Act for a period of five years from the date of the order. The bidder or contractor or subcontractor, respectively, acknowledges that the chief procurement officer may declare the contract void if this certification is false.

The undersigned, on behalf of the subcontracting company, has read and understands the above certifications and makes the certifications as required by law.

<hr/>		
Name of Subcontracting Company		
<hr/>		<hr/>
Authorized Officer		Date

RETURN WITH SUBCONTRACT

SUBCONTRACTOR DISCLOSURES

I. DISCLOSURES

- A. The disclosures hereinafter made by the subcontractor are each a material representation of fact upon which reliance is placed. The subcontractor further certifies that the Department has received the disclosure forms for each subcontract.

The chief procurement officer may void the bid, contract, or subcontract, respectively, if it is later determined that the bidder or subcontractor rendered a false or erroneous disclosure. A contractor or subcontractor may be suspended or debarred for violations of the Procurement Code. Furthermore, the chief procurement officer may void the contract or subcontract.

B. Financial Interests and Conflicts of Interest

1. Section 50-35 of the Illinois Procurement Code provides that all subcontracts of more than \$10,000 shall be accompanied by disclosure of the financial interests of the subcontractor. This disclosed information for the subcontractor, will be maintained as public information subject to release by request pursuant to the Freedom of Information Act, filed with the Procurement Policy Board, and shall be incorporated as a material term of the Prime Contractor's contract. Furthermore, pursuant to this Section, the Procurement Policy Board may recommend to allow or void a contract or subcontract based on a potential conflict of interest.

The financial interests to be disclosed shall include ownership or distributive income share that is in excess of 5%, or an amount greater than 60% of the annual salary of the Governor, of the subcontracting entity or its parent entity, whichever is less, unless the subcontractor is a publicly traded entity subject to Federal 10K reporting, in which case it may submit its 10K disclosure in place of the prescribed disclosure. If a subcontractor is a privately held entity that is exempt from Federal 10K reporting, but has more than 400 shareholders, it may submit the information that Federal 10K companies are required to report, and list the names of any person or entity holding any ownership share that is in excess of 5%. The disclosure shall include the names, addresses, and dollar or proportionate share of ownership of each person making the disclosure, their instrument of ownership or beneficial relationship, and notice of any potential conflict of interest resulting from the current ownership or beneficial interest of each person making the disclosure having any of the relationships identified in Section 50-35 and on the disclosure form.

In addition, all disclosures shall indicate any other current or pending contracts, subcontracts, proposals, leases, or other ongoing procurement relationships the subcontracting entity has with any other unit of state government and shall clearly identify the unit and the contract, subcontract, proposal, lease, or other relationship.

2. Disclosure Forms. Disclosure Form A is attached for use concerning the individuals meeting the above ownership or distributive share requirements. Subject individuals should be covered each by one form. In addition, a second form (Disclosure Form B) provides for the disclosure of current or pending procurement relationships with other (non-IDOT) state agencies. **The forms must be included with each bid or incorporated by reference.**

C. Disclosure Form Instructions

Form A Instructions for Financial Information & Potential Conflicts of Interest

If the subcontractor is a publicly traded entity subject to Federal 10K reporting, the 10K Report may be submitted to meet the requirements of Form A. If a subcontractor is a privately held entity that is exempt from Federal 10K reporting, but has more than 400 shareholders, it may submit the information that Federal 10K companies are required to report, and list the names of any person or entity holding any ownership share that is in excess of 5%. If a subcontractor is not subject to Federal 10K reporting, the subcontractor must determine if any individuals are required by law to complete a financial disclosure form. To do this, the subcontractor should answer each of the following questions. A "YES" answer indicates Form A must be completed. If the answer to each of the following questions is "NO", then the NOT APPLICABLE STATEMENT on the second page of Form A must be signed and dated by a person that is authorized to execute contracts for the subcontracting company. Note: These questions are for assistance only and are not required to be completed.

1. Does anyone in your organization have a direct or beneficial ownership share of greater than 5% of the bidding entity or parent entity? YES ___ NO ___
2. Does anyone in your organization have a direct or beneficial ownership share of less than 5%, but which has a value greater than \$106,447.20? YES ___ NO ___
3. Does anyone in your organization receive more than \$106,447.20 of the subcontracting entity's or parent entity's distributive income? (Note: Distributive income is, for these purposes, any type of distribution of profits. An annual salary is not distributive income.) YES ___ NO ___
4. Does anyone in your organization receive greater than 5% of the subcontracting entity's or parent entity's total distributive income, but which is less than \$106,447.20? YES ___ NO ___

(Note: Only one set of forms needs to be completed per person per subcontract even if a specific individual would require a yes answer to more than one question.)

A "YES" answer to any of these questions requires the completion of Form A. The subcontractor must determine each individual in the subcontracting entity or the subcontracting entity's parent company that would cause the questions to be answered "Yes". Each form must be signed and dated by a person that is authorized to execute contracts for your organization. **Photocopied or stamped signatures are not acceptable.** The person signing can be, but does not have to be, the person for which the form is being completed. The subcontractor is responsible for the accuracy of any information provided.

If the answer to each of the above questions is "NO", then the NOT APPLICABLE STATEMENT on page 2 of Form A must be signed and dated by a person that is authorized to execute contracts for your company.

RETURN WITH SUBCONTRACT

Form B: Instructions for Identifying Other Contracts & Procurement Related Information

Disclosure Form B must be completed for each subcontract submitted by the subcontracting entity. *Note: Checking the NOT APPLICABLE STATEMENT on Form A does not allow the subcontractor to ignore Form B. Form B must be completed, checked, and dated or the subcontract will not be approved.*

The Subcontractor shall identify, by checking Yes or No on Form B, whether it has any pending contracts, subcontracts, leases, bids, proposals, or other ongoing procurement relationship with any other (non-IDOT) State of Illinois agency. If "No" is checked, the subcontractor only needs to complete the check box on the bottom of Form B. If "Yes" is checked, the subcontractor must list all non-IDOT State of Illinois agency pending contracts, subcontracts, leases, bids, proposals, and other ongoing procurement relationships. These items may be listed on Form B or on an attached sheet(s). Contracts with cities, counties, villages, etc. are not considered State of Illinois agency contracts and are not to be included. Contracts or subcontracts with other State of Illinois agencies such as the Department of Natural Resources or the Capital Development Board must be included.

ILLINOIS DEPARTMENT OF TRANSPORTATION

Form A Subcontractor: Financial Information & Potential Conflicts of Interest Disclosure

Subcontractor Name, Legal Address, City, State, Zip, Telephone Number, Email Address, Fax Number (if available)

Disclosure of the information contained in this Form is required by the Section 50-35 of the Illinois Procurement Code (30 ILCS 500). Subcontractors desiring to enter into a subcontract of a State of Illinois contract must disclose the financial information and potential conflict of interest information as specified in this Disclosure Form. This information shall become part of the publicly available contract file. This Form A must be completed for bids in excess of \$10,000, and for all open-ended contracts. A publicly traded company may submit a 10K disclosure (or equivalent if applicable) in satisfaction of the requirements set forth in Form A. See Disclosure Form Instructions.

DISCLOSURE OF FINANCIAL INFORMATION

1. Disclosure of Financial Information. The individual named below has an interest in the SUBCONTRACTOR (or its parent) in terms of ownership or distributive income share in excess of 5%, or an interest which has a value of more than \$106,447.20 (60% of the Governor's salary as of 7/1/07). (Make copies of this form as necessary and attach a separate Disclosure Form A for each individual meeting these requirements)

FOR INDIVIDUAL (type or print information) NAME: ADDRESS Type of ownership/distributable income share: stock sole proprietorship Partnership other: (explain on separate sheet): % or \$ value of ownership/distributable income share:

2. Disclosure of Potential Conflicts of Interest. Check "Yes" or "No" to indicate which, if any, of the following potential conflict of interest relationships apply. If the answer to any question is "Yes", please attach additional pages and describe.

(a) State employment, currently or in the previous 3 years, including contractual employment of services. Yes ___ No ___

If your answer is yes, please answer each of the following questions.

1. Are you currently an officer or employee of either the Capitol Development Board or the Illinois Toll Highway Authority? Yes ___ No ___

2. Are you currently appointed to or employed by any agency of the State of Illinois? If you are currently appointed to or employed by any agency of the State of Illinois, and your annual salary exceeds \$106,447.20, (60% of the Governor's salary as of 7/1/07) provide the name the State agency for which you are employed and your annual salary.

RETURN WITH SUBCONTRACT

3. If you are currently appointed to or employed by any agency of the State of Illinois, and your annual salary exceeds \$106,447.20, (60% of the Governor's salary as of 7/1/07) are you entitled to receive (i) more than 7 1/2% of the total distributable income of your firm, partnership, association or corporation, or (ii) an amount in excess of the salary of the Governor? Yes ___ No ___
4. If you are currently appointed to or employed by any agency of the State of Illinois, and your annual salary exceeds \$106,447.20, (60% of the Governor's salary as of 7/1/07) are you and your spouse or minor children entitled to receive (i) more than 15 % in the aggregate of the total distributable income of your firm, partnership, association or corporation, or (ii) an amount in excess of 2 times the salary of the Governor? Yes ___ No ___

(b) State employment of spouse, father, mother, son, or daughter, including contractual employment services in the previous 2 years.

Yes ___ No ___

If your answer is yes, please answer each of the following questions.

1. Is your spouse or any minor children currently an officer or employee of the Capitol Development Board or the Illinois Toll Highway Authority? Yes ___ No ___
2. Is your spouse or any minor children currently appointed to or employed by any agency of the State of Illinois? If your spouse or minor children is/are currently appointed to or employed by any agency of the State of Illinois, and his/her annual salary exceeds \$106,447.20, (60 % of the Governor's salary as of 7/1/07) provide the name of your spouse and/or minor children, the name of the State agency for which he/she is employed and his/her annual salary. _____

3. If your spouse or any minor children is/are currently appointed to or employed by any agency of the State of Illinois, and his/her annual salary exceeds \$106,447.20, (60% of the salary of the Governor as of 7/1/07) are you entitled to receive (i) more then 71/2% of the total distributable income of your firm, partnership, association or corporation, or (ii) an amount in excess of the salary of the Governor? Yes ___ No ___

4. If your spouse or any minor children are currently appointed to or employed by any agency of the State of Illinois, and his/her annual salary exceeds \$106,447.20, (60% of the Governor's salary as of 7/1/07) are you and your spouse or minor children entitled to receive (i) more than 15 % in the aggregate of the total distributable income of your firm, partnership, association or corporation, or (ii) an amount in excess of 2 times the salary of the Governor? Yes ___ No ___

(c) Elective status; the holding of elective office of the State of Illinois, the government of the United States, any unit of local government authorized by the Constitution of the State of Illinois or the statutes of the State of Illinois currently or in the previous 3 years. Yes ___ No ___

(d) Relationship to anyone holding elective office currently or in the previous 2 years; spouse, father, mother, son, or daughter. Yes ___ No ___

(e) Appointive office; the holding of any appointive government office of the State of Illinois, the United States of America, or any unit of local government authorized by the Constitution of the State of Illinois or the statutes of the State of Illinois, which office entitles the holder to compensation in excess of the expenses incurred in the discharge of that office currently or in the previous 3 years. Yes ___ No ___

(f) Relationship to anyone holding appointive office currently or in the previous 2 years; spouse, father, mother, son, or daughter. Yes ___ No ___

(g) Employment, currently or in the previous 3 years, as or by any registered lobbyist of the State government. Yes ___ No ___

RETURN WITH SUBCONTRACT

(h) Relationship to anyone who is or was a registered lobbyist in the previous 2 years; spouse, father, mother, son, or daughter. Yes ___ No ___

(i) Compensated employment, currently or in the previous 3 years, by any registered election or reelection committee registered with the Secretary of State or any county clerk of the State of Illinois, or any political action committee registered with either the Secretary of State or the Federal Board of Elections. Yes ___ No ___

(j) Relationship to anyone; spouse, father, mother, son, or daughter; who was a compensated employee in the last 2 years by any registered election or re-election committee registered with the Secretary of State or any county clerk of the State of Illinois, or any political action committee registered with either the Secretary of State or the Federal Board of Elections. Yes ___ No ___

APPLICABLE STATEMENT

This Disclosure Form A is submitted on behalf of the INDIVIDUAL named on previous page. Under penalty of perjury, I certify the contents of this disclosure to be true and accurate to the best of my knowledge.

Completed by: _____ Date _____
Signature of Individual or Authorized Officer

NOT APPLICABLE STATEMENT

Under penalty of perjury, I have determined that no individuals associated with this organization meet the criteria that would require the completion of this Form A.

This Disclosure Form A is submitted on behalf of the SUBCONTRACTOR listed on the previous page.

_____ Date _____
Signature of Authorized Officer

RETURN WITH SUBCONTRACT

ILLINOIS DEPARTMENT
OF TRANSPORTATION

Form B
Subcontractor: Other Contracts &
Procurement Related Information
Disclosure

Subcontractor Name		
Legal Address		
City, State, Zip		
Telephone Number	Email Address	Fax Number (if available)

Disclosure of the information contained in this Form is required by the Section 50-35 of the Illinois Procurement Act (30 ILCS 500). This information shall become part of the publicly available contract file. This Form B must be completed for bids in excess of \$10,000, and for all open-ended contracts.

DISCLOSURE OF OTHER CONTRACTS, SUBCONTRACTS, AND PROCUREMENT RELATED INFORMATION

1. Identifying Other Contracts & Procurement Related Information. The SUBCONTRACTOR shall identify whether it has any pending contracts, subcontracts, including leases, bids, proposals, or other ongoing procurement relationship with any other State of Illinois agency: Yes ___ No ___

If "No" is checked, the subcontractor only needs to complete the signature box on the bottom of this page.

2. If "Yes" is checked. Identify each such relationship by showing State of Illinois agency name and other descriptive information such as bid or project number (attach additional pages as necessary). SEE DISCLOSURE FORM INSTRUCTIONS:

THE FOLLOWING STATEMENT MUST BE CHECKED

<input type="checkbox"/>	_____	_____
	Signature of Authorized Officer	Date



NOTICE TO BIDDERS

- 1. TIME AND PLACE OF OPENING BIDS.** Sealed proposals for the improvement described herein will be received by the Department of Transportation at the Harry R. Hanley Building, 2300 South Dirksen Parkway, in Springfield, Illinois until 10:00 o'clock a.m., July 30, 2010. All bids will be gathered, sorted, publicly opened and read in the auditorium at the Department of Transportation's Harry R. Hanley Building shortly after the 10:00 a.m. cut off time.
- 2. DESCRIPTION OF WORK.** The proposed improvement is identified and advertised for bids in the Invitation for Bids as:

**Contract No. 74296
EFFINGHAM County
Section (25-3)R,BY,BR
Route FAI 57/70
District 7 Construction Funds**

2.10 miles of interstate reconstruction upgrades from 4-lanes to 6-lanes, resurfacing, highway lighting, replacement of 2 structures and rehabilitation of 2 structures all on I-57/70 located south of Effingham (SN 025-0001, 0018, 0009 and 0010).

- 3. INSTRUCTIONS TO BIDDERS.** (a) This Notice, the invitation for bids, proposal and letter of award shall, together with all other documents in accordance with Article 101.09 of the Standard Specifications for Road and Bridge Construction, become part of the contract. Bidders are cautioned to read and examine carefully all documents, to make all required inspections, and to inquire or seek explanation of the same prior to submission of a bid.

(b) State law, and, if the work is to be paid wholly or in part with Federal-aid funds, Federal law requires the bidder to make various certifications as a part of the proposal and contract. By execution and submission of the proposal, the bidder makes the certification contained therein. A false or fraudulent certification shall, in addition to all other remedies provided by law, be a breach of contract and may result in termination of the contract.
- 4. AWARD CRITERIA AND REJECTION OF BIDS.** This contract will be awarded to the lowest responsive and responsible bidder considering conformity with the terms and conditions established by the Department in the rules, Invitation for Bids and contract documents. The issuance of plans and proposal forms for bidding based upon a prequalification rating shall not be the sole determinant of responsibility. The Department reserves the right to determine responsibility at the time of award, to reject any or all proposals, to readvertise the proposed improvement, and to waive technicalities.

By Order of the
Illinois Department of Transportation

Gary Hannig,
Secretary

INDEX FOR SUPPLEMENTAL SPECIFICATIONS
 AND RECURRING SPECIAL PROVISIONS

Adopted January 1, 2010

This index contains a listing of SUPPLEMENTAL SPECIFICATIONS and frequently used RECURRING SPECIAL PROVISIONS.

ERRATA Standard Specifications for Road and Bridge Construction (Adopted 1-1-07) (Revised 1-1-10)

SUPPLEMENTAL SPECIFICATIONS

<u>Std. Spec. Sec.</u>	<u>Page No.</u>
201 Clearing, Tree Removal and Protection	1
205 Embankment	2
251 Mulch	3
253 Planting Woody Plants	4
280 Temporary Erosion Control	6
406 Hot-Mix Asphalt Binder and Surface Course	7
443 Reflective Crack Control Treatment	12
502 Excavation for Structures	15
503 Concrete Structures	16
504 Precast Concrete Structures	17
505 Steel Structures	18
540 Box Culverts	19
581 Waterproofing Membrane System	20
630 Steel Plate Beam Guardrail	21
633 Removing and Reerecting Guardrail and Terminals	22
637 Concrete Barrier	23
669 Removal and Disposal of Regulated Substances	24
672 Sealing Abandoned Water Wells	25
701 Work Zone Traffic Control and Protection	26
720 Sign Panels and Appurtenances	27
721 Sign Panel Overlay	28
722 Demountable Sign Legend Characters and Arrows	29
726 Mile Post Marker Assembly	30
733 Overhead Sign Structures	31
783 Pavement Marking and Marker Removal	32
801 Electrical Requirements	33
805 Electrical Service Installation – Traffic Signals	34
836 Pole Foundation	35
838 Breakaway Devices	36
862 Uninterruptable Power Supply	37
873 Electric Cable	39
878 Traffic Signal Concrete Foundation	41
1003 Fine Aggregates	42
1004 Coarse Aggregates	43
1005 Stone and Broken Concrete	44
1006 Metals	45
1008 Structural Steel Coatings	47
1010 Finely Divided Materials	48
1020 Portland Cement Concrete	49
1022 Concrete Curing Materials	58
1024 Nonshrink Grout	59
1030 Hot-Mix Asphalt	60
1032 Bituminous Materials	65

1042	Precast Concrete Products	68
1062	Reflective Crack Control System	70
1069	Pole and Tower	72
1074	Control Equipment	75
1076	Wire and Cable	80
1080	Fabric Materials	81
1081	Materials for Planting	82
1083	Elastomeric Bearings	84
1090	Sign Base	85
1091	Sign Face	87
1092	Sign Legend and Supplemental Panels	95
1093	Sign Supports	96
1094	Overhead Sign Structures	98
1095	Pavement Markings	104
1101	General Equipment	106
1102	Hot-Mix Asphalt Equipment	107
1103	Portland Cement Concrete Equipment	109
1106	Work Zone Traffic Control Devices	110

RECURRING SPECIAL PROVISIONS

The following RECURRING SPECIAL PROVISIONS indicated by an "X" are applicable to this contract and are included by reference:

<u>CHECK SHEET #</u>	<u>PAGE NO.</u>
1	111
2	114
3 X	115
4 X	125
5 X	130
6	135
7	136
8 X	137
9	138
10 X	141
11	144
12	146
13	150
14 X	152
15	153
16	155
17	156
18	158
19 X	159
20 X	160
21	164
22	166
23	168
24 X	170
25 X	171
26	172
27	173
28 X	174
29	175
30	176
31	184
32	196
33	197

TABLE OF CONTENTS

LOCATION OF PROJECT 1

DESCRIPTION OF PROJECT 1

COOPERATION BETWEEN CONTRACTORS..... 2

ENDANGERED AND THREATENED SPECIES 2

SEQUENCE OF CONSTRUCTION..... 2

RESTRICTIONS TO THE CONTRACTORS OPERATIONS 3

EMBANKMENT 4

BORROW AREAS, USE AREAS, AND/OR WASTE AREAS 5

CLASS BS AGGREGATE OPTIMIZATION 5

EXTENDED LIFE CONCRETE..... 5

PAVEMENT JOINTS, TIE-BARS AND DOWEL BARS 6

WIDE FLANGE BEAM TERMINAL JOINT COMPLETE (SPECIAL)..... 6

REMOVAL OF EXISTING RAISED REFLECTIVE PAVEMENT MARKERS 7

APPROACH SLAB REMOVAL 7

PAVEMENT REMOVAL 7

PAVEMENT REMOVAL (SPECIAL) 7

HOT-MIX ASPHALT REMOVAL (SPECIAL) 8

AGGREGATE SHOULDERS, TYPE B 6" 8

REMOVE EXISTING FLARED END SECTION..... 8

CONCRETE HEADWALL REMOVAL 9

REMOVE AND RELAY END SECTIONS 9

REMOVE AND RELAY PIPE CULVERTS..... 9

PIPES TO BE ABANDONED 9

CONCRETE HEADWALLS 10

METAL END SECTIONS 10

CONCRETE COLLAR..... 10

CONCRETE THRUST BLOCKS..... 11

CONCRETE ANCHORS 11

PIPE UNDERDRAINS (SPECIAL)..... 11

REMOVE AND RELOCATE INLETS 11

TYPE C INLET BOX, STANDARD 609001 (SPECIAL)..... 12

TEMPORARY INLETS 12

CONCRETE MEDIAN SURFACE, 6 INCH (SPECIAL) 12

TRAFFIC BARRIER TERMINALS 13

REMOVAL AND REINSTALLATION OF EXISTING STEEL PLATE BEAM GUARD RAIL, SINGLE RAIL
 13

REMOVE AND RE-ERECT STEEL PLATE BEAM GUARD RAIL 13

TEMPORARY GUARD RAIL 13

GUARDRAIL REMOVAL.....	14
IMPACT ATTENUATORS, RELOCATE (FULLY REDIRECTIVE), TEST LEVEL 3.....	14
TRAFFIC CONTROL PLAN.....	14
KEEPING THE ROADS OPEN TO TRAFFIC.....	15
CHANGEABLE MESSAGE SIGNS.....	17
TRAFFIC CONTROL PLAN (FOR BRIDGE PROJECTS).....	18
CONTRACTOR ACCESS OPENINGS.....	22
LIGHTING FOR NIGHTTIME HIGHWAY CONSTRUCTION.....	22
LINEAR DELINEATION PANELS.....	25
TRAFFIC CONTROL FOR ROAD CLOSURE.....	26
TRAFFIC CONTROL AND PROTECTION (DETOUR 1).....	26
TRAFFIC CONTROL AND PROTECTION, (SPECIAL).....	27
WET REFLECTIVE TEMPORARY PAVEMENT MARKING TAPE, TYPE III.....	27
WET REFLECTIVE TEMPORARY TAPE, TYPE III, INTERSTATE SHIELD.....	28
PAVEMENT MARKING GROOVING.....	29
URETHANE PAVEMENT MARKING.....	30
PREFORMED THERMOPLASTIC PAVEMENT MARKING SHIELD.....	35
TRAFFIC COUNTER.....	37
PVC CONDUIT.....	38
LUMINAIRE TESTING.....	38
LIGHTING CONTROLLER, BASE MOUNTED, 480VOLT, 100AMP.....	40
LIGHTING CONTROLLER, BASE MOUNTED, 480VOLT, 200AMP.....	40
SEISMIC RESTRAINERS.....	40
UN SOUND CONCRETE REMOVAL.....	44
DRAINAGE SYSTEM.....	45
JACK AND REMOVE EXISTING BEARINGS.....	46
CLEANING AND PAINTING CONTACT SURFACE AREAS OF EXISTING STEEL STRUCTURES.....	47
CLEANING AND PAINTING NEW METAL STRUCTURES.....	52
CLEANING AND PAINTING EXISTING STEEL STRUCTURES.....	60
DECK SLAB REPAIR.....	79
BRIDGE DECK MICROSILICA CONCRETE OVERLAY.....	84
UNDERWATER STRUCTURE EXCAVATION PROTECTION.....	95
TEMPORARY SOIL RETENTION SYSTEM.....	96
PIPE UNDERDRAINS FOR STRUCTURES.....	97
POROUS GRANULAR EMBANKMENT, SPECIAL.....	98
STRUCTURAL REPAIR OF CONCRETE.....	98
MECHANICAL SPLICERS.....	107
DIAMOND GRINDING AND SURFACE TESTING BRIDGE SECTIONS.....	107
CONTAINMENT AND DISPOSAL OF NON-LEAD PAINT CLEANING RESIDUES.....	115

DEMOLITION PLANS FOR REMOVAL OF EXISTING STRUCTURES	130
PILING.....	130
ALKALI-SILICA REACTION FOR CAST-IN-PLACE CONCRETE (BDE)	132
ALKALI-SILICA REACTION FOR PRECAST AND PRECAST PRESTRESSED CONCRETE (BDE)	135
APPROVAL OF PROPOSED BORROW AREAS, USE AREAS, AND/OR WASTE AREAS INSIDE ILLINOIS STATE BORDERS (BDE)	137
AUTOMATED FLAGGER ASSISTANCE DEVICES (BDE).....	138
CEMENT (BDE)	139
CONCRETE ADMIXTURES (BDE)	141
CONCRETE MIX DESIGNS (BDE)	144
CONSTRUCTION AIR QUALITY - DIESEL VEHICLE EMISSIONS CONTROL (BDE)	146
CONSTRUCTION AIR QUALITY - IDLING RESTRICTIONS (BDE).....	147
DETERMINATION OF THICKNESS (BDE).....	148
DISADVANTAGED BUSINESS ENTERPRISE PARTICIPATION (BDE)	158
DOWEL BARS (BDE)	165
ENGINEER'S FIELD OFFICE TYPE A (BDE).....	165
EQUIPMENT RENTAL RATES (BDE).....	167
HOT-MIX ASPHALT – ANTI-STRIPPING ADDITIVE (BDE).....	168
HOT-MIX ASPHALT - DENSITY TESTING OF LONGITUDINAL JOINTS (BDE)	169
HOT-MIX ASPHALT – DROP-OFFS (BDE)	170
HOT-MIX ASPHALT - FINE AGGREGATE (BDE)	170
HOT-MIX ASPHALT – PLANT TEST FREQUENCY (BDE).....	171
HOT-MIX ASPHALT – QC/QA ACCEPTANCE CRITERIA (BDE)	172
HOT-MIX ASPHALT – TRANSPORTATION (BDE)	172
IMPACT ATTENUATORS (BDE).....	173
IMPACT ATTENUATORS, TEMPORARY (BDE).....	174
IMPROVED SUBGRADE (BDE).....	176
LIQUIDATED DAMAGES (BDE).....	178
MATERIAL TRANSFER DEVICE (BDE)	178
METAL HARDWARE CAST INTO CONCRETE (BDE).....	179
MULTILANE PAVEMENT PATCHING (BDE).....	180
NATIONAL POLLUTANT DISCHARGE ELIMINATION SYSTEM / EROSION AND SEDIMENT CONTROL DEFICIENCY DEDUCTION (BDE)	180
NOTIFICATION OF REDUCED WIDTH (BDE)	181
ORGANIC ZINC-RICH PAINT SYSTEM (BDE).....	182
PARTIAL EXIT RAMP CLOSURE FOR FREEWAY/EXPRESSWAY (BDE)	185
PAVEMENT MARKING REMOVAL (BDE).....	186
PAVEMENT PATCHING (BDE).....	186
PAYMENTS TO SUBCONTRACTORS (BDE)	186

PERSONAL PROTECTIVE EQUIPMENT (BDE)	187
PIPE CULVERTS (BDE)	188
PORTLAND CEMENT CONCRETE PLANTS (BDE)	191
POST CLIPS FOR EXTRUDED ALUMINUM SIGNS (BDE)	192
PRECAST CONCRETE HANDLING HOLES (BDE)	192
RAISED REFLECTIVE PAVEMENT MARKERS (BDE)	194
RAMP CLOSURE FOR FREEWAY/EXPRESSWAY (BDE)	194
RECLAIMED ASPHALT PAVEMENT (RAP) (BDE)	195
REFLECTIVE SHEETING ON CHANNELIZING DEVICES (BDE)	202
REINFORCEMENT BARS - STORAGE AND PROTECTION (BDE)	202
SEEDING (BDE)	203
SELF-CONSOLIDATING CONCRETE FOR PRECAST PRODUCTS (BDE)	205
SUBCONTRACTOR MOBILIZATION PAYMENTS (BDE)	207
SURFACE TESTING OF PAVEMENTS (BDE)	207
TEMPORARY EROSION CONTROL (BDE)	213
TRAFFIC BARRIER TERMINAL, TYPE 6 (BDE)	215
TRUCK MOUNTED/TRAILER MOUNTED ATTENUATORS (BDE)	215
COMPLETION DATE PLUS GUARANTEED WORKING DAYS	215
BITUMINOUS MATERIALS COST ADJUSTMENTS (BDE) (RETURN FORM WITH BID)	216
FUEL COST ADJUSTMENT (BDE) (RETURN FORM WITH BID)	219
STEEL COST ADJUSTMENT (BDE) (RETURN FORM WITH BID)	223
PROJECT LABOR AGREEMENT	227
STORM WATER POLLUTION PREVENTION PLAN	241
ROCKFILL - REPLACEMENT	253

STATE OF ILLINOIS

SPECIAL PROVISIONS

The following Special Provisions supplement the "Standard Specifications for Road and Bridge Construction," adopted January 1, 2007, the latest edition of the "Manual on Uniform Traffic Control Devices for Streets and Highways," and the "Manual of Test Procedures for Materials" in effect on the date of invitation for bids, and the Supplemental Specifications and Recurring Special Provisions indicated on the Check Sheet included herein which apply to and govern the construction of FAI Routes 57/70 (I-57/70), Section (25-3)R,BY,BR, Effingham County, Contract No. 74296, and in case of conflict with any part or parts of said Specifications, the said Special Provisions shall take precedence and shall govern.

LOCATION OF PROJECT

The work on this project is located on FAI Routes 57 and 70 and the Tri-Level Complex from West of the Little Wabash River to West of US Route 40 in Effingham County, Illinois.

DESCRIPTION OF PROJECT

The work in this project consists of 2.1 miles of pavement reconstruction and resurfacing operations to facilitate the interstate reconstruction and resurfacing on FAI Routes 57 and 70 and the Tri-Level Complex from West of Little Wabash River to West of US Route 40 in Effingham County, Illinois.

Work items include furnished and earth excavation, pipe culvert extension, box culvert extensions, storm sewers, inlets and manholes, lime modified soils, stabilized subbase, jointed PCC pavement and shoulders, continuously reinforced pavement and shoulders, hot-mix asphalt surface removal, pavement patching, polymerized hot-mix asphalt surface course, hot-mix asphalt shoulders, aggregate shoulders, pipe underdrains, combination concrete curb and gutters, concrete median surface course (special) double face concrete barrier median, impact attenuators, route signing including overhead sign trusses, lighting, seeding, temporary erosion control measures, permanent and temporary pavement marking, and all other necessary and collateral work to complete the project as shown on the plans and as specified elsewhere in these provisions.

This work also includes the extension of the subway tunnel structures carrying the mainline roadways over Township Rd 1354. The extensions include concrete box culverts, epoxy coated reinforcement bars, geocomposite wall drains, epoxy crack injection, porous granular embankment, and all necessary and collateral work to complete the extensions as shown on the plans.

This work also consists of the removal of the existing structures carrying FAI Route 70 over Little Wabash River and the construction of replacement structures including stone riprap, structure and cofferdam excavation, cofferdams, concrete structures and concrete superstructures, epoxy coated and reinforcement bars, PCC Bulb T-Beams, steel piling, Diamond Grinding, and all miscellaneous and collateral work necessary to complete the removal and replacement of the structures as shown on the plans.

This work also consists of the Bridge Repair operations to the structures carrying Roadway C (FAI-57 Southbound) and Ramp F over Roadway B (FAI Route 70 Eastbound) including jacking and bearing replacement, seismic cable restrainers, bridge deck scarification, microsilica concrete overlay, miscellaneous concrete repair, and all necessary and collateral work required to complete the repairs as shown on the plans.

COOPERATION BETWEEN CONTRACTORS

The Contractor for this contract is advised that other projects within or adjacent to the limits of this contract section may be under construction during construction operations for this contract. The Contractor for this section shall cooperate with the Contractor for the other projects according to Article 105.08 of the Standard Specifications.

The following projects may be under construction while this contract is in force:

FAI Routes 57/70, Section (25-3,4)R, Effingham County, Contract No. 74299 - This project consists of the pavement reconstruction operations to expand the existing 4 lane roadway to a six lane fully access controlled facility with interchange reconstruction at Fayette Ave. This project is located at the eastern terminus of this contract.

ENDANGERED AND THREATENED SPECIES

The Contractor for this project is advised of the presence of the Kirtland Snake within the limits of this project. The Kirtland snake is an endangered and threatened species and all applicable laws pertinent to the protection of the species shall be observed in accordance with Section 107 of the Standard Specifications.

The Contractor shall take whatever precautions necessary to prevent disturbance of any areas found to contain the Kirtland Snake and notify the Engineer of its location. The areas shall remain undisturbed until such time as the Engineer gives written permission to do so.

SEQUENCE OF CONSTRUCTION

The Contractor for this construction contract is advised that he/she will be required to conduct and coordinate construction operations for project as shown on the plans, as directed by the Engineer, in accordance with the applicable portions of the Standard Specifications, and as specified elsewhere in these provisions.

This contract is divided into three separate construction sections. A general sequence of construction has been outlined for each section with maintenance of traffic for each shown on the plans and as herein specified.

Stage construction operations are coordinated between the Set 1 and Set 2 plans for this project. Set 3 plans must be coordinated such that Roadway C bridge repairs are completed during the Pre-Stage 1 portion of the mainline contracts and that Ramp F repairs are completed during the road closure as specified elsewhere in these provisions.

The Sequence of Construction as outlined is the suggested sequence and deviations will not be permitted without written approval of the Engineer.

The Contractor is further advised that stage construction operations and traffic management are key elements of the Sequence of Construction and may control when traffic shifts may be incorporated. The Contractor shall not accelerate any portion of construction or construction staging for this project without approval of the Engineer.

Portions of the project that are not subject to stage construction or traffic management may be accomplished at any time at the Contractors discretion.

The Contractor shall take into account the requirements as herein specified in submitting the contract unit prices for the various items of work for this contract as no additional compensation will be allowed for any costs incurred for delays or restrictions to the Contractors operations that result directly from compliance with the requirements of this provision.

RESTRICTIONS TO THE CONTRACTORS OPERATIONS

The Contractor for this project is advised that certain operations will be restricted for this project as follows:

- No Contractor or worker vehicles shall be parked within the Interstate Highway Right of Way.
- The Contractor will not be permitted to establish a staging or material/equipment storage area within the Interstate Highway Right of Way unless otherwise approved by the Engineer.
- The Contractor will be permitted to work on Legal Holidays with the following restrictions: All of the Contractors work operations shall be behind temporary concrete barrier. Due to anticipated increase in traffic volumes the contractor will not be permitted to complete any work activities that would require vehicles or equipment to intermittently enter and exit the work area through access openings in the temporary concrete barrier. Any work activities planned over a Legal Holiday must be approved in advance by the Engineer. A Legal Holiday is as defined in Article 107.09 of The Standard specifications for Road and Bridge Construction Adopted January 1, 2007.
- The Access Control within the limits for this project will be strictly enforced. Any exceptions to the Access Control must be coordinated and approved by the Federal Highway Administration (FHWA). Exceptions to the Access Control cannot be discussed during the letting process from the project advertisement to the award of the contract.

The Contractor shall take into account the requirements and restrictions to the Contractors operations in submitting the contract unit prices for the various items for this project as no additional compensation will be allowed for any costs incurred or for delays to the Contractors operations that are the direct result of compliance with this provision.

EMBANKMENT

October 2009

Embankments shall be constructed according to Sections 202, 204 and 205 of the Standard Specifications and as required, or modified, in this Special Provision.

When embankments are to be constructed on hillsides or existing slopes which are steeper than 3H:1V, steps shall be keyed into the existing slope by stepping and benching as shown in the plans or as directed by the Engineer.

All material proposed for use in embankment construction shall be approved by the Engineer. In addition to the requirements of Section 204, soils exhibiting the following properties shall not be allowed:

Liquid Limit (AASHTO T 89) greater than 60.

Soils exhibiting the following properties shall be restricted to the interior of the embankment:

Less than 35% passing the #200 sieve.

Liquid Limit (AASHTO T 89) greater than 50 but less than 60.

Plasticity Index (AASHTO T 90) less than 12.

These restricted soils shall be encapsulated by a minimum of two (2) feet of unrestricted soil as directed by the Engineer. The thickness of encapsulation shall not include topsoil. The Engineer may restrict or prohibit the use of materials other than those identified above, which exhibit potential for significant erosion or excessive volume change.

Where lime modified soil is shown on the plans, materials placed in the top two (2) feet of embankments shall have a clay content greater than or equal to 20% over the width of improved subgrade. Clay is defined according to AASHTO M 145. Clay content shall be determined according to AASHTO T 88.

The moisture content of all embankment lifts, including embankment placed adjacent to a structure, shall not exceed 110% of the optimum moisture determined according to AASHTO T 99 (Method C). If the Engineer determines the embankment lifts are unstable after achieving the required density, the Contractor shall reprocess and compact the unstable material as directed by the Engineer. The Engineer may reduce the allowable moisture content to correct or prevent stability problems during embankment construction.

When proposed embankment height is greater than 30 ft, any embankment lift shall provide a minimum Immediate Bearing Value (IBV) of 3.0 when tested by the Engineer according to Illinois Testing Procedure 501 or 502. Any embankment lift not providing the minimum required IBV will be removed and replaced, modified and/or re-processed, to provide an IBV of 3.0. The volume of material covered by this requirement includes the entire cross sectional area of the embankment, greater than 30 ft height, and an additional 250 ft in each direction of the starting and ending station where the embankment height is greater than 30 ft.

This work will not be paid for separately, but shall be considered included in the unit prices for Earth Excavation, Borrow, and/or Furnished Excavation as included in the project.

BORROW AREAS, USE AREAS, AND/OR WASTE AREAS

Effective: November, 2009

In addition to the provisions contained in Article 107.22 of the Standard Specifications, any required submittal(s) to the District office shall require four (4) copies sent for processing. All copies of pictures submitted shall be in color.

CLASS BS AGGREGATE OPTIMIZATION

For superstructure construction, Class BS concrete shall contain a blend of two or more coarse aggregate sizes blended in accordance with Article 1004.02(d). The blended aggregate will consist of CA-7 or CA-11 with CA-13, CA14, or CA-16. The blended coarse aggregate gradation shall have a minimum of 45 percent passing the 1/2 in. (12.5 mm) sieve and a maximum of 60 percent passing the 1/2 in. (12.5 mm) at the discretion of the Engineer.

The cost of compliance with this requirement shall be considered included in the cost of CONCRETE SUPERSTRUCTURES.

EXTENDED LIFE CONCRETE

Description: This work shall consist of constructing pavement, shoulders, median, curb, gutter, combination curb and gutter and concrete barrier. Work shall be performed according to the Standard Specifications except as modified herein:

Pavement and Shoulders: Add the following to Articles 420.03, 421.03, and 483.03:

“The Contractor shall submit to the Engineer, for approval before paving, the proposed internal type vibrator spacing for the paver. The Contractor shall also provide the proposed vibrator operating frequencies for a paving speed greater than or equal to 3 ft. /min. and a paving speed less than 3 ft/min.”

Add the following to Articles 420.07, 421.04 (a), and 483.05:

“When the surface temperature, as measured on the surface with a device as approved by the Engineer, of the Stabilized Sub-base is 115°F or greater the Contractor shall spray the Stabilized Sub-base with a water mist with equipment that meets the approval of the Engineer. The Stabilized Sub-base shall be cooled below 115°F prior to paving on top. The water spray shall not produce excessive water runoff or leave puddles on the Stabilized Sub-base at the time of paving. All cooling shall be completed a minimum of 10 minutes prior to paving. The surface temperature shall be monitored during the paving operation to determine if the Stabilized Sub-base requires re-spraying.

The water used shall meet the requirements of Section 1002.”

Portland Cement Concrete:” Revise Article 1020.02 (d) to read:

“(d) Coarse Aggregate (Note 1)1004.01 – 1004.02”

Add the following to Article 1020.02:

“Note 1. For pavement, shoulders, median, curb, gutter, combination curb and gutter and concrete barrier, the freeze-thaw rating expansion limit for the coarse aggregate shall be a maximum of 0.040 percent according to Illinois Modified AASHTO T 161, Procedure B.”

Revise the curing table of Article 1020.13 as follows:

“The curing period for pavement, shoulders, median, curb, gutter and combination curb and gutter and concrete barrier shall be a minimum of 7 days.”

Revise the first sentence of the second paragraph of Article 1020.13 (a)(4) to read:

“Membrane curing shall be completed within ten minutes after tinning or final finishing.”

Add the following to Article 1020.14(a):

“Prior to placing concrete, the Contractor shall indicate to the Engineer how the temperature of the concrete mixture will be controlled. If the temperature requirements are not being met, production of concrete shall stop until corrective action is taken. The Contractor will be allowed to deliver concrete already in route to the paving site.”

Revise Article 1020.14(a) paragraph 2

“The temperature of the concrete immediately before placement shall be a minimum of 50 F (4 C) and a maximum of 90 F (32 C).

The additional costs to meet the various material, equipment, placement, finishing, curing, and sealing requirements for extended life concrete will not be paid for separately, but included in the cost for CONTINUOUSLY REINFORCED PORTLAND CEMENT CONCRETE PAVEMENT 13 inch, PORTLAND CEMENT CONCRETE PAVEMENT 10 inch (JOINTED), CONCRETE MEDIAN SURFACE 6 inch (SPECIAL), CONCRETE BARRIER DOUBLE FACE 42inch HEIGHT, and COMBINATION CONCRETE CURB AND GUTTER TYPE B 6.24.

PAVEMENT JOINTS, TIE-BARS AND DOWEL BARS

This work consists of the construction of pavement joints and bars as shown on the plans, as directed by the Engineer, and in accordance with Sections 420 and 421 of the Standard Specifications.

Joints, tie-bars and dowel bars required for the construction of pavement joints for the various types of pavement, including ramp terminals and diverging or converging roadways, shall conform to the appropriate Highway Standard Drawings and details shown on the plans.

All pavement joints including tie-bars and dowel bars will not be paid for separately but considered as in the contract unit prices for the various types of pavement.

WIDE FLANGE BEAM TERMINAL JOINT COMPLETE (SPECIAL)

This work consists of the construction of wide flange beam terminal joints at locations shown on the plans, as directed by the Engineer, and in accordance with Section 421 of the Standard Specifications.

Wide flange beam terminal joints to be constructed under this item vary in width of roadway they are to be constructed on. The width of the joint shall include the pavement and shoulder areas as shown on the plans.

This work will be paid for at the contract unit price each for WIDE FLANGE BEAM TERMINAL JOINT COMPLETE (SPECIAL), which price shall be payment in full for the limits of each complete installation.

REMOVAL OF EXISTING RAISED REFLECTIVE PAVEMENT MARKERS

The removal of existing raised reflective pavement markers in the resurfacing areas shall be included in the contract unit price per square yard (square meter) for HOT-MIX ASPHALT SURFACE REMOVAL of the thickness shown on the plans. Removal of the markers in the reconstruction areas will not be measured for payment but included in the costs of pavement removal or reconstruction operations.

APPROACH SLAB REMOVAL

This work consists of the removal and satisfactory disposal of existing approach pavements at locations shown on the plans, as directed by the Engineer, and in accordance with Section 440 of the Standard Specifications.

Approach pavements to be removed under this item are overlaid reinforced concrete slabs to be completely removed and the timber piling shall be cut off 3 feet below the proposed grade.

This work will be paid for at the contract unit price per square yard for APPROACH SLAB REMOVAL as herein specified.

PAVEMENT REMOVAL

This work consists of the removal and satisfactory disposal of existing pavements as shown on the plans, as directed by the Engineer, and in accordance with Section 440 of the Standard Specifications.

Pavements to be removed under this item are the existing pavements to be removed for reconstruction of the ramps and roadways for this project. The original concrete pavements have been overlaid numerous times and it is estimated to have approximately 6 inches of hot-mix asphalt material on them. In addition, some pavements to be removed under this item will be overlaid during stage construction operations.

This work will be paid for at the contract unit price per square yard for PAVEMENT REMOVAL, as herein specified.

PAVEMENT REMOVAL (SPECIAL)

This work consists of the removal and satisfactory disposal of temporary concrete pavements as shown on the plans, as directed by the Engineer, and in accordance with Section 440 of the Standard Specifications.

Pavements to be removed under this item are temporary reinforced concrete pavements constructed as part of the stage construction operations for this project.

This work will be paid for at the contract unit price per square yard for PAVEMENT REMOVAL (SPECIAL), as herein specified.

HOT-MIX ASPHALT REMOVAL (SPECIAL)

This work consists of the removal and satisfactory disposal of miscellaneous bituminous pavements or surfaces as shown on the plans, as directed by the Engineer, in accordance with Section 440 of the Standard specifications, and as herein specified.

The miscellaneous pavement to be removed under this item is believed to be an aggregate base with several applications of bituminous surface treatment. It is possible that bituminous concrete has been utilized at some time.

The removal of miscellaneous bituminous pavements as herein specified shall include any bases including the aggregate base.

This work will be paid for at the contract unit price per square yard for HOT-MIX ASPHALT REMOVAL (SPECIAL) as herein specified.

AGGREGATE SHOULDERS, TYPE B 6"

This work consists of the construction of aggregate shoulders as shown on the plans, as directed by the Engineer, and in accordance with Section 481 of the Standard Specifications

Materials utilized for aggregate shoulders shall be crushed stone.

This work will be paid for at the contract unit price per square yard for AGGREGATE SHOULDERS, TYPE B 6".

REMOVE EXISTING FLARED END SECTION

This work consists of the removal of existing reinforced concrete flared end sections at locations shown on the plans, as directed by the Engineer, and in accordance with the applicable portions of Section 501 of the Standard Specifications.

The flared end sections to be removed under this item vary in size and may include grating for flared end sections. The flared end sections removed under this item shall become the property of the Contractor and any salvage value shall be reflected in the contract unit price bid for this item.

This work will be paid for at the contract unit price each for REMOVE EXISTING FLARED END SECTION, as herein specified.

CONCRETE HEADWALL REMOVAL

This work consists of the removal and satisfactory disposal of existing concrete headwalls as shown on the plans, as directed by the Engineer, and in accordance with Section 501 of the standard Specifications.

Headwalls to be removed under this item are for pipe culverts and are to be removed in conjunction with culvert extensions. The headwalls shall be removed completely including the wingwalls, aprons, and toe walls unless otherwise directed by the Engineer. The headwalls to be removed are for pipe culverts that range in size from 36 inches to 84 inches.

This work will be paid for at the contract unit price each for CONCRETE HEADWALL REMOVAL, as herein specified.

REMOVE AND RELAY END SECTIONS

This work consists of the removal and relaying of existing flared end sections as shown on the plans, as directed by the Engineer, and in accordance with the applicable portions of Sections 501 and 542 of the Standard Specifications.

The end sections to be removed and relayed under this item may vary in size and may include grating for end sections.

This work will be paid for at the contract unit price each for REMOVE AND RELAY END SECTIONS, as herein specified.

REMOVE AND RELAY PIPE CULVERTS

This work consists of removing and relaying pipe culverts as shown on the plans or as directed by the Engineer, and in accordance with Section 501 and 542 of the Standard Specifications.

Pipe culverts to be removed and relayed under this item are those associated with pipe culvert extensions and it may be necessary to adjust the existing culverts due to poor joint connection or joint separation as directed by the Engineer.

This work will not be measured for payment separately but considered as included in the cost of the PIPE CULVERTS of the class and type specified.

PIPES TO BE ABANDONED

This work consists of abandoning existing pipe culverts or storm sewers as shown on the plans, or as directed by the Engineer, in accordance with Section 550 and 593 of the Standard Specifications, except as herein specified.

In addition to the requirements of Section 550, pipes or sewers to be abandoned shall be filled with a Controlled Low Strength Material or grout mixture meeting the approval of the Engineer.

Holes may be placed in the top of the pipes to be abandoned in order to facilitate the filling of the pipe.

This work will not be measured for payment but considered as included in the costs of EARTH EXCAVATION.

CONCRETE HEADWALLS

This work consists of the construction of concrete headwalls at locations as shown on the plans, as directed by the Engineer, and in accordance with the applicable portions of Section 542 of the Standard Specifications.

Concrete headwalls to be constructed under this item are used in conjunction with pipe drain or culvert outflows as shown on the plans.

This work will be paid for at the contract unit price per cubic yard for CONCRETE HEADWALL as herein specified.

METAL END SECTIONS

This work consists of the construction of metal end sections as shown on the plans, as directed by the Engineer and in accordance with Section 542 of the Standard Specifications.

The Contractor shall have the option of constructing steel or aluminum sections as specified in Article 542.07(c) of the Standard Specifications.

This work will be paid for at the contract unit price each for METAL END SECTIONS, of the diameter specified.

CONCRETE COLLAR

This work consists of the construction of concrete connection collars at locations shown on the plans, as directed by the Engineer, and in accordance with the applicable portions of Section 542 of the Standard Specifications except as herein specified.

Concrete connection collars to be constructed under this item consist of reinforced concrete collars as detailed on the plans. The collars generally are required in the extension of pipe culverts and are used to join existing pipes with the proposed pipe extensions. The Contractor may elect to remove the existing pipe to the nearest satisfactory joint and provide the additional pipe length necessary to accommodate the extension at no additional costs.

Class SI Concrete shall be used throughout and reinforcement shall conform to AASHTO M 170 for Class III pipe or as otherwise directed by the Engineer.

This work will be paid for at the contract unit price each for CONCRETE COLLAR including reinforcement as herein specified.

CONCRETE THRUST BLOCKS

This work consists of the construction of concrete thrust blocks at locations shown on the plans, as directed by the Engineer, and according to Section 609 of the Standard Specifications, and as herein specified.

Concrete thrust blocks as herein specified shall conform to the requirements of Article 609.06 of the Standard Specifications and will vary in size as shown on the plans.

This work will be paid for at the contract unit price each for CONCRETE THRUST BLOCKS which price shall be payment in full regardless of size required.

CONCRETE ANCHORS

This work consists of the construction of concrete anchors to hold down pipe drains on steep slopes as shown on the plans, as directed by the Engineer, according to the applicable portions of Section 609 of the Standard Specifications, and as herein specified.

Concrete anchors to be constructed under this item, shall be cast-in-place of Class SI Concrete. The concrete anchors will vary in size as shown on the plans.

This work will be paid for at the contract unit price each for CONCRETE ANCHORS, as herein specified.

PIPE UNDERDRAINS (SPECIAL)

This work consists of the construction of pipe underdrains (special) as shown on the plans, as directed by the Engineer, and in accordance with Section 601 of the Standard Specifications.

This work will be paid for at the contract unit price per foot for PIPE UNDERDRAINS (SPECIAL), of the diameter specified.

REMOVE AND RELOCATE INLETS

The work consists of removing and relocating existing inlets at locations shown on the plans, as directed by the Engineer and in accordance with Sections 602 and 605 of the Standard Specifications, and as herein specified.

The inlet to be removed and relocated under this item is a sloping inlet box generally conforming to the Highway Standard Drawings with 10:1 slopes.

This work will be paid for at the contract unit price each for REMOVE AND RELOCATE INLETS, as herein specified.

TYPE C INLET BOX, STANDARD 609001 (SPECIAL)

This work consists of the construction of a new inlet box in conjunction with new approach pavement shoulders as shown on the plans, as directed by the Engineer, and in accordance with Sections 609 and 610 of the Standard Specifications.

An Inlet Box Type C conforming to Highway Standard 609001 shall be constructed in conjunction with PCC Bridge Approach Shoulder Pavement. The inlet box and shoulder pavement is to be constructed adjacent to Bridge Approach Pavement Connector (PCC) outside the limits of the Approach Slab as included in Plan Set 3 of 3.

This work will be paid for at the contract unit price each for TYPE C INLET BOX, STANDARD 609001 (SPECIAL), as herein specified.

TEMPORARY INLETS

This work consists of the construction and removal of temporary inlets at locations shown on the plans, as directed by the Engineer and in accordance with the applicable portions of Sections 501 and 602 of the Standard Specifications.

Temporary inlets to be constructed under this item shall include Type 15 Frame and Closed Lids. These inlets are to be constructed to facilitate drainage during stage construction operations for this project. Any removal and replacement of existing curb and gutters necessary due to the construction of the temporary inlets as herein specified will not be paid for separately but considered as included in the construction of the temporary inlet. When the temporary inlets are no longer required they shall be removed and if indicated, the outflow pipes are to be abandoned as specified elsewhere in these provisions.

This work will be paid for at the contract unit price each for TEMPORARY INLETS, as herein specified.

CONCRETE MEDIAN SURFACE, 6 INCH (SPECIAL)

This work consists of the construction of concrete median surface as shown on the plans, as directed by the Engineer, and in accordance with Section 483 and 606 of the Standard Specifications.

The cross section of the concrete median surface shall conform to the details shown on the plans. Contraction joints shall be placed at 20 foot intervals. Expansion joints shall be prolongations of the adjacent pavement and shoulders. 1" sealed preformed expansion joint filler shall be placed along the edge of the median surface to separate the concrete barrier median. Coarse aggregate to be placed below the concrete median surface will not be paid for separately but considered as included in the cost of constructing the concrete median.

This work will be paid for at the contract unit price per square foot for CONCRETE MEDIAN SU

TRAFFIC BARRIER TERMINALS

Holes required for attaching traffic barrier terminals to structures shall be formed or cored. Drilled holes will not be permitted.

REMOVAL AND REINSTALLATION OF EXISTING STEEL PLATE BEAM GUARD RAIL, SINGLE RAIL

This work consists of the removal and reinstallation of existing steel plate beam guard rail and guardrail terminals at locations shown on the plans, as directed by the Engineer, and in accordance with Section 633 of the Standard Specifications, except as herein specified.

Guardrail and terminals to be removed and reinstalled under this item are existing guardrail installations that shall be removed and reinstalled at another location during stage construction operations as shown on the plans. It is the intent to reuse all existing elements in the reinstallation except that all new bolts, nuts, and washers shall be used throughout the reinstallation work.

This work will be paid for at the contract unit price per foot for REMOVAL AND REINSTALLATION OF EXISTING STEEL PLATE BEAM GUARD RAIL, SINGLE RAIL, as herein specified.

REMOVE AND RE-ERECT STEEL PLATE BEAM GUARD RAIL

This work consists of the removal and re-erecting of existing steel plate beam guard rail and guardrail terminals at locations shown on the plans, as directed by the Engineer, and in accordance with Section 633 of the Standard Specifications, except as herein specified.

Guardrail and terminals to be removed and re-erected under this item are existing guardrail installations that shall be removed and re-erected at the same location during stage construction operations as shown on the plans. Vertical differences in elevation of pavements will occur during stage construction operations and the existing installations must be adjusted vertically. It is the intent to reuse all existing elements in the re-erection operation except that all new bolts, nuts, and washers shall be used throughout the work.

This work will be paid for at the contract unit price per foot for REMOVE AND RE-ERECT STEEL PLATE BEAM GUARD RAIL, as herein specified.

TEMPORARY GUARD RAIL

This work consists of the furnishing, erecting, maintaining, and the removal of temporary guardrail at locations shown on the plans, as directed by the Engineer, in accordance with the applicable portions of Sections 630 and 632 of the Standard Specifications, and as herein specified.

Temporary guardrail required under this item is that required during stage construction operations. Temporary guardrail will be required to extend lengths of installations to be performed under other items of work as specified elsewhere in these provisions.

Guardrail to be installed under this item shall meet the requirements of Type A Rail as shown on the plans except that existing elements may be salvaged or previously used and meet the approval of the Engineer. All bolts, nuts and washers shall be new.

This work will be paid for at the contract unit price per foot for TEMPORARY GUARD RAIL as herein specified.

GUARDRAIL REMOVAL

This work consists of the removal of existing guardrail at locations shown on the plans, as directed by the Engineer, in accordance with the applicable portions of Section 632 of the Standard Specifications, and as herein specified.

Guardrail to be removed under this item is existing guardrail installations including traffic barrier terminals. Temporary guardrail removal, as specified elsewhere in these provisions, will not be measured for payment under this item.

This work will be paid for at the contract unit price per foot for GUARDRAIL REMOVAL, as herein specified.

IMPACT ATTENUATORS, RELOCATE (FULLY REDIRECTIVE), TEST LEVEL 3

This work consists of the relocation of existing impact attenuator as shown on the plans, as directed by the Engineer as herein specified and as specified elsewhere in these provisions.

The attenuator to be relocated under this item is an existing galvanized all steel construction attenuator attached to the existing concrete barrier median. The Contractor shall exercise care in the relocation of the existing attenuator so as to not damage any portion of the existing attenuator or the existing concrete barrier. All existing bolts shall be cut off and any damage or spalling of the concrete shall be repaired. All mounting hardware required for the new installation shall be new and a new concrete base will be required.

This work will be paid for at the contract unit price each for IMPACT ATTENUATORS, RELOCATE (FULLY REDIRECTIVE), TEST LEVEL 3, as herein specified.

TRAFFIC CONTROL PLAN

Effective: July 12, 1993

Revised: May 12, 1997

Traffic control shall be in accordance with the applicable sections of the "Standard Specifications for Road and Bridge Construction", the applicable guidelines contained in the "Manual on Uniform Traffic Control Devices for Streets and Highways", Illinois Supplement to the Manual of Uniform Traffic Control Devices, these Special Provisions, and any special details and Highway Standards contained herein and in the plans.

Special attention is called to Articles 107.09 and 107.14 of the "Standard Specifications for Road and Bridge Construction and the following Highway Standards relating to traffic control:

701101 701106 701201 701301 701400 701401 701402 701406
701411 701426 701451 701456 701901 704001 BLR 21 BLR 22

In addition, the following Special Provision(s) will also govern traffic control for this project:

SEQUENCE OF CONSTRUCTION
RESTRICTION TO THE CONTRACTORS OPERATIONS
KEEPING THE ROADS OPEN TO TRAFFIC
TRAFFIC CONTROL PLAN (FOR BRIDGE PROJECTS)
CONTRACTOR ACCESS OPENINGS
LIGHTING FOR NIGHTTIME HIGHWAY CONSTRUCTION
LINEAR DELINEATION PANELS
TRAFFIC CONTROL FOR ROAD CLOSURE
TRAFFIC CONTROL AND PROTECTION DETOUR 1
TRAFFIC CONTROL AND PROTECTION, (SPECIAL)
WET REFLECTIVE TEMPORARY PAVEMENT MARKING TAPE, TYPE III
WET REFLECTIVE TEMPORARY TAPE, TYPE III, INTERSTATE SHIELD
AUTOMATED FLAGGER ASSISTANCE DEVICE (BDE)
MULTILANE PAVEMENT PATCHING (BDE)
NOTIFICATION OF REDUCED WIDTH (BDE)
PARTIAL EXIT RAMP CLOSURE FOR FREEWAYS/EXPRESSWAYS (BDE)
PAVEMENT PATCHING (BDE)
PERSONAL PROTECTIVE EQUIPMENT (BDE)
REFLECTIVE SHEETING ON CHANNELIZING DEVICES (BDE)

KEEPING THE ROADS OPEN TO TRAFFIC

The Contractor for this Section is advised that he/she will be required to conduct and coordinate the construction operations for this project in such a manner so as to cause the least interference or inconvenience to the motoring public and to otherwise maintain traffic as herein specified.

FAI Route 70 West Approach to South Tri-Level Complex

Two lanes of traffic in each direction shall be maintained at all times except when stage construction operations require the closure of one lane of traffic in each direction and appropriate traffic control is installed as shown on the plans and as specified elsewhere in these provisions.

FAI Routes 57 and 70 South Tri-Level Roadways

Two lanes of traffic in each direction shall be maintained at all times except when stage construction operations require the closure of one lane of traffic in each direction and appropriate traffic control is installed as shown on the plans and as specified elsewhere in these provisions.

FAI Route 57/70 East Approach:

Two lanes of traffic in each direction shall be maintained at all times except when stage construction operations require the closure of one lane of traffic in each direction and appropriate traffic control is installed as shown on the plans and as specified elsewhere in these provisions.

South Tri-Level Ramp F:

One lane of traffic shall be maintained at all times during construction operations except for Stage Pre-Stage 1 operations and Stage 1 Roadway A operations when the ramp may be closed and all traffic detoured as shown on the plans and as specified elsewhere in these provisions.

South Tri-Level Ramp G:

One lane of traffic shall be maintained at all times during stage construction operations and traffic control installed as shown on the plans and as directed by the Engineer.

US Route 40:

One lane of traffic in each direction shall be maintained at all times except when construction operations for the proposed lighting require the closure of a lane of traffic during working hours only and appropriate traffic control is installed meeting the approval of the Engineer.

Frontage Roads:

Traffic patterns for the frontage roads shall be maintained at all times except when construction operations require the closure of the frontage roads to traffic and appropriate traffic control meeting the approval of the Engineer is installed. The Contractor is advised that the primary use of the frontage roads is that associated with agricultural operations with the exception of one private residence. Access to the private residence by means of Frontage Road 2 must be maintained at all times. The Contractor shall also cooperate and coordinate with the agricultural operations in the local area such to minimize the restrictions to access to the west side of the interstate. The closure or otherwise restrictions to access to the west side will be limited to actual construction operations for the extension of the subway tunnel structures. Access shall be provided at all other times.

General:

No stoppage of traffic or lane closures will be permitted on any roadway or ramp within the projects limits except as authorized directly in the Traffic Control Plan for this project.

No overnight lane closures will be permitted on any of the roadways or ramps within the project limits except as outlined for Pre-Stage 1 operations and Bridge Repair as specified elsewhere in these provisions.

Advance warning signs shall be installed on all ramps, roadways, and frontage roads within the limits of this project.

These signs shall be installed prior to performing work on this project and shall remain in place for the duration of this contract unless otherwise directed by the Engineer. Costs for the advance warning signs will not be paid for separately but considered included in the other items of work.

Changeable Message Signs shall also be installed 10 miles in advance of each interstate roadway approach to construction operations for this project. This provision is in addition to message signs required under the Maintenance of Traffic as shown on the plans and Highway Standards. These Changeable Message Signs as herein specified shall be installed in advance to any construction operations for this project and remain in place for the duration of this contract. These changeable message signs, as installed on each interstate roadway approach, will be paid for separately as CHANGEABLE MESSAGE SIGNS as specified elsewhere in these provisions.

Lane restrictions or closures for the construction of this project are subject to stage construction and traffic management operations as shown on the plans and as indicated in the Sequence of Construction for this project. The Contractor is advised that with the exception bridge repair operation outlined for Plan Set 3 of 3, construction of temporary pavements and lane restrictions for mainline roadways as outlined for Pre-Stage 1 shall be performed at night during off-peak hours. All lanes shall be re-opened to traffic during peak hours for Pre-Stage 1 and for holidays or weekends as specified in Article 107.09. For the purposes of this provision, peak hours are defined as follows: From 7:00 am to 7:00 pm.

Removal of paved shoulder, required for Pre-Stage 1 construction of temporary pavements, shall be limited to a length of removed shoulder that can be filled in the same night. No open trenches or holes adjacent to lanes open to traffic will be permitted during daylight hours.

The Contractor shall take into account the requirements for maintaining traffic as herein specified in submitting the contract unit prices for the various items of work, as no additional compensation will be allowed for any cost or delays that result from compliance with this provision.

CHANGEABLE MESSAGE SIGNS

This work consists of the furnishing, the installation, maintenance, and removal of changeable message signs as directed by the Engineer, in accordance with Section 701 of the Standard Specifications, and as herein specified.

Changeable message signs to be installed under this item are those to be installed on each interstate roadway approach to construction operations for this project. These are as specified in Keeping the Roads Open to Traffic elsewhere in these provisions.

This work will be paid for at the contract unit price per calendar month for each sign as CHANGEABLE MESSAGE SIGN, as herein specified.

TRAFFIC CONTROL PLAN (FOR BRIDGE PROJECTS)

Traffic Control shall be in accordance with the applicable sections of the Standard Specifications for Road and Bridge Construction, the applicable guidelines contained in the Illinois Manual on Uniform Traffic Control Devices for Streets and Highways, these Special Provisions, and any special details and Highway Standards contained herein and in the plans.

Special attention is called to Articles 107.09, 107.14 and 107.15 of the Standard Specifications for Road and Bridge Construction, the Highway Standards and Special Provisions relating to traffic control as specified in the **Traffic Control Plan** elsewhere in these special provisions.

The following provisions shall also apply to the traffic control for this project:

Bridge Width Restriction Signs: The contractor shall furnish and install the following signs to advise motorists of the width restriction created by the stage construction bridge work. The signs shall be installed on posts or skids, unless otherwise specified, at the locations listed below:

Pre-Stage 1 (WB):

Two each "BRIDGE CONSTRUCTION 2 MILES AHEAD, MAXIMUM WIDTH 10 FT 6 IN." with the sign dimensions (60" x 48" each) with I-57 Route Shield. To be installed on entrance ramps (2) from Fayette Avenue onto I-57/70 WB (Exit 159).

One each "BRIDGE CONSTRUCTION 3 MILES AHEAD, MAXIMUM WIDTH 10 FT 6 IN." with the sign dimensions (60" x 48") with I-57 Route Shield. To be installed on entrance ramp from Keller Avenue onto I-57/70 WB (Exit 160).

One each "BRIDGE CONSTRUCTION 5 MILES AHEAD, MAXIMUM WIDTH 10 FT 6 IN." with the sign dimensions (60" x 48") with I-57 Route Shield. To be installed on entrance ramp from US Route 45 onto I-57/70 WB (Exit 162).

Two each "BRIDGE CONSTRUCTION 5 MILES AHEAD, MAXIMUM WIDTH 10 FT 6 IN." with the sign dimensions (60" x 48" each) with I-57 Route Shield. To be installed along I-57/70 WB just east of US Route 45 (Exit 162).

One each "BRIDGE CONSTRUCTION 20 MILES AHEAD, MAXIMUM WIDTH 10 FT 6 IN." with the sign dimensions (60" x 48"). To be installed along I-57 SB just north of US Route 45 (County Road 500E) (Exit 177).

One each "BRIDGE CONSTRUCTION 20 MILES AHEAD, MAXIMUM WIDTH 10 FT 6 IN." with the sign dimensions (60" x 48"). To be installed on entrance ramp from US Route 45 (County Road 500E) onto I-57 SB (Exit 177).

Stage 1 (EB):

Two each "BRIDGE CONSTRUCTION 9 MILES AHEAD, MAXIMUM WIDTH 11 FT 6 IN." with the sign dimensions (60" x 48" each). To be installed along I-70 just west of IL 128 (Exit 82).

One each "BRIDGE CONSTRUCTION 9 MILES AHEAD, MAXIMUM WIDTH 11 FT 6 IN." with the sign dimensions (60" x 48"). To be installed on entrance ramp from IL 128 onto I-70 West (Exit 82).

Two each "BRIDGE CONSTRUCTION 15 MILES AHEAD, MAXIMUM WIDTH 11 FT 6 IN." with the sign dimensions (60" x 48" each). To be installed along I-70 West just west of County Road 7 (Exit 76).

One each "BRIDGE CONSTRUCTION 15 MILES AHEAD, MAXIMUM WIDTH 11 FT 6 IN." with the sign dimensions (60" x 48"). To be installed on entrance ramp from County Road 7 onto I-70 West (Exit 76).

Stage 1 (WB):

Two each "BRIDGE CONSTRUCTION 3 MILES AHEAD, MAXIMUM WIDTH 11 FT 6 IN." with the sign dimensions (60" x 48" each) with I-70 Route Shield. To be installed on entrance ramps (2) from Fayette Avenue onto I-57/70 WB (Exit 159).

One each "BRIDGE CONSTRUCTION 4 MILES AHEAD, MAXIMUM WIDTH 11 FT 6 IN." with the sign dimensions (60" x 48") with I-70 Route Shield. To be installed on entrance ramp from Keller Avenue onto I-57/70 WB (Exit 160).

One each "BRIDGE CONSTRUCTION 6 MILES AHEAD, MAXIMUM WIDTH 11 FT 6 IN." with the sign dimensions (60" x 48") with I-70 Route Shield. To be installed on entrance ramp from US Route 45 onto I-57/70 WB (Exit 162).

Two each "BRIDGE CONSTRUCTION 6 MILES AHEAD, MAXIMUM WIDTH 11 FT 6 IN." with the sign dimensions (60" x 48" each) with I-70 Route Shield. To be installed along I-57/70 WB just east of US Route 45 (Exit 162).

One each "BRIDGE CONSTRUCTION 15 MILES AHEAD, MAXIMUM WIDTH 11 FT 6 IN." with the sign dimensions (60" x 48"). To be installed along I-70 WB just east of County Road 2300E (Exit 105).

One each "BRIDGE CONSTRUCTION 15 MILES AHEAD, MAXIMUM WIDTH 11 FT 6 IN." with the sign dimensions (60" x 48"). To be installed on entrance ramp from County Road 2300E onto I-70 WB (Exit 105).

Stage 2 (EB):

Two each "BRIDGE CONSTRUCTION 9 MILES AHEAD, MAXIMUM WIDTH 13 FT 0 IN." with the sign dimensions (60" x 48" each). To be installed along I-70 EB just west of IL 128 (Exit 82).

One each "BRIDGE CONSTRUCTION 9 MILES AHEAD, MAXIMUM WIDTH 13 FT 0 IN." with the sign dimensions (60" x 48"). To be installed on entrance ramp from IL 128 onto I-70 West (Exit 82).

Two each "BRIDGE CONSTRUCTION 15 MILES AHEAD, MAXIMUM WIDTH 13 FT 0 IN." with the sign dimensions (60" x 48" each). To be installed along I-70 EB just west of County Road 7 (Exit 76).

One each "BRIDGE CONSTRUCTION 15 MILES AHEAD, MAXIMUM WIDTH 13 FT 0 IN." with the sign dimensions (60" x 48"). To be installed on entrance ramp from County Road 7 onto I-70 West (Exit 76).

Stage 2 (WB):

One each "BRIDGE CONSTRUCTION 1 MILE AHEAD, MAXIMUM WIDTH 13 FT 0 IN." with the sign dimensions (60" x 48"). To be installed on ramp from I-57 NB to I-70 WB (Exit 157).

One each "BRIDGE CONSTRUCTION 2 MILES AHEAD, MAXIMUM WIDTH 13 FT 0 IN." with the sign dimensions (60" x 48") with I-70 Route Shield. To be installed along I-57 NB just south of exit ramp to I-70 WB (Exit 157).

Two each "BRIDGE CONSTRUCTION 3 MILES AHEAD, MAXIMUM WIDTH 13 FT 0 IN." with the sign dimensions (60" x 48" each) with I-70 Route Shield. To be installed on entrance ramps (2) from Fayette Avenue onto I-57/70 WB (Exit 159).

One each "BRIDGE CONSTRUCTION 4 MILES AHEAD, MAXIMUM WIDTH 13 FT 0 IN." with the sign dimensions (60" x 48") with I-70 Route Shield. To be installed on entrance ramp from Keller Avenue onto I-57/70 WB (Exit 160).

One each "BRIDGE CONSTRUCTION 6 MILES AHEAD, MAXIMUM WIDTH 13 FT 0 IN." with the sign dimensions (60" x 48") with I-70 Route Shield. To be installed on entrance ramp from US Route 45 onto I-57/70 WB (Exit 162).

Two each "BRIDGE CONSTRUCTION 6 MILES AHEAD, MAXIMUM WIDTH 13 FT 0 IN." with the sign dimensions (60" x 48" each) with I-70 Route Shield. To be installed along I-57/70 WB just east of US Route 45 (Exit 162).

One each "BRIDGE CONSTRUCTION 15 MILES AHEAD, MAXIMUM WIDTH 13 FT 0 IN." with the sign dimensions (60" x 48"). To be installed along I-70 WB just east of County Road 2300E (Exit 105).

One each "BRIDGE CONSTRUCTION 15 MILES AHEAD, MAXIMUM WIDTH 13 FT 0 IN." with the sign dimensions (60" x 48"). To be installed on entrance ramp from County Road 2300E onto I-70 WB (Exit 105).

The Engineer shall approve the exact locations of all proposed signs and barricades prior to installation. Installation shall be in accordance with Standard 701901.

District 7 will provide all route shields for the Contractors use on this project. The remaining signs shall be furnished by the Contractor and shall conform to the dimensions and text as shown on the drawing included herein.

When the width displayed on the signs must be changed as determined by the Engineer for the second stage of construction, materials to modify the signs shall be furnished and installed by the contractor.

The Contractor shall be responsible for the maintenance of the barricades and signs during the life of the project. The Contractor shall ensure the continual visibility of these signs is maintained and not obstructed by vegetation or other obstacles.

The signs shall be promptly removed when the restriction is no longer in effect.

The cost of furnishing, installing, maintaining and removing width restriction signs and wing barricades as herein specified will not be paid for separately, but considered as included in the costs of TRAFFIC CONTROL AND PROTECTION (SPECIAL), as specified elsewhere in these provisions.

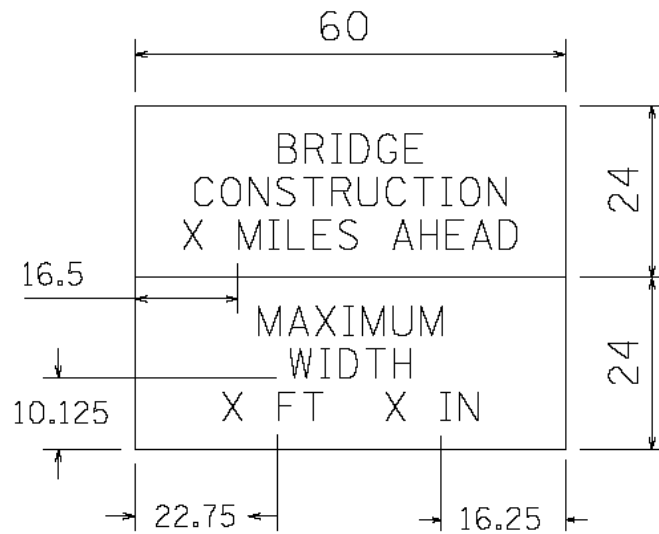
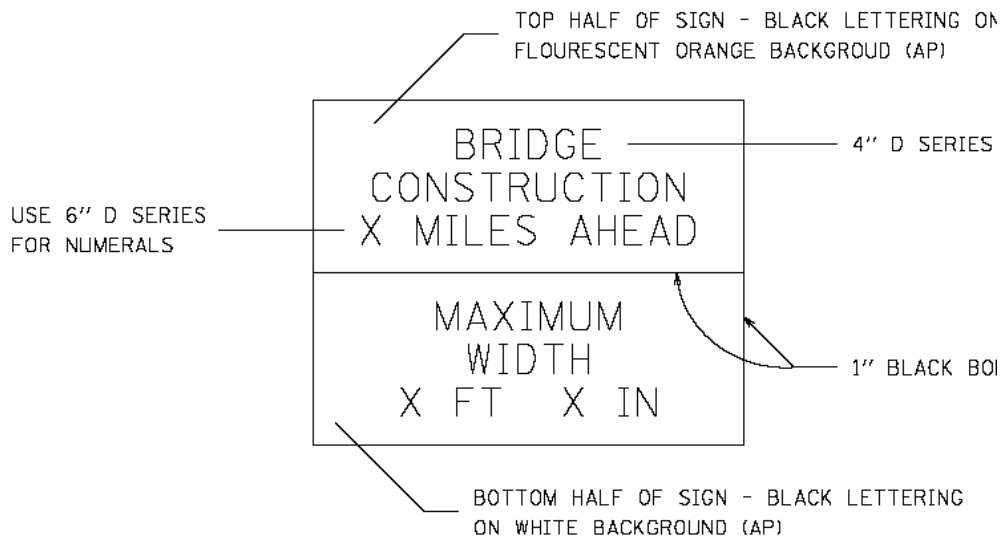

NOTE: ALL DIMINSIONS ARE IN INCHES

CONTRACTOR ACCESS OPENINGS

The Contractor for this contract is advised that provisions for the Sequence of Construction and Maintenance of Traffic for the Stage Construction Operations for this project have been included in the plans and special provisions. Some of the Contractors access and construction operations will be restricted due to the use of temporary concrete barriers and other traffic control measures. The Contractor will be permitted to provide access openings in the concrete barriers and general traffic control devices in accordance with the details on the plans.

The access openings will be restricted to 2,000 foot intervals per eastbound traffic and 2,000 foot for westbound traffic. Access openings shall not be located opposite of each other. Temporary concrete barriers and impact attenuators shall meet the same requirements for traffic control devices for this project as provided for elsewhere except the impact attenuators need not be new but must be certified by the Contractor. The Contractor shall provide additional traffic control and flaggers meeting the approval of the Engineer while the access openings are in use and barricades or drums shall be placed across the openings when they are not in use.

The Contractor shall be responsible for all costs associated with the operation of the access openings including constructing temporary access pads in order for vehicles to cross over into the construction areas.

The plans and estimated quantities for the Maintenance of Traffic items do not provide for Contractor Access Openings as herein specified. No deductions of lengths of temporary concrete barrier will be made from plan quantities due to the installation of Contractor Access Openings.

This item will not be measured for payment but considered as included in various items of work and traffic control.

The Contractors shall take into account the requirements for constructing Contractor Access Openings as herein specified in submitting the contract unit prices for the various items of work and traffic control as no additional compensation will be allowed for the construction of the Contractor Access Openings as herein specified.

LIGHTING FOR NIGHTTIME HIGHWAY CONSTRUCTION

Description: This work shall consist of furnishing, installing, operating, maintaining, moving and removing all necessary lighting equipment and materials for the duration of nighttime operations on the contract. Night time operations shall consist of work which occurs shortly before sunset until after sunrise. All work shall be done according to the "Standard Specifications for Road and Bridge Construction" and as further defined herein.

Materials: Furnished lighting equipment may include fixed and/or mobile lighting systems. The term fixed lighting systems shall include portable lighting supports and luminaries and may take the form of roadway luminaries on temporary poles. The term mobile lighting systems shall include luminaries attached to mobile construction equipment. Other lighting systems, such as balloon lighting, may be adapted to both fixed and mobile lighting.

All lighting equipment shall be in good operating condition and in compliance with applicable safety and design codes to the satisfaction of the Engineer and shall meet the glare requirements.

General Requirements: Whenever the Contractor's operations are being conducted at night, the Contractor shall provide such artificial lighting as determined by the Engineer to ensure safety, quality of construction, and adequate conditions for inspection of the work by the Engineer. If multiple operations are underway simultaneously at various locations, lighting meeting the specifications herein shall be provided at each separate work area.

Lighting requirements in this specification are not intended to be a substitute for other required safety measures, including: reflective clothing, traffic control devices, warning lights, barricades, drums, cones, and signs. All vehicles in the work zone shall have properly functioning vehicle headlights and all contractors' vehicles and construction equipment shall have amber flashing or strobe lights.

Lighting Levels: Unless specified otherwise within this specification, the contractor shall provide a minimum lighting level of 54 lux (5fc) throughout the immediate work area. Lighting levels will be measured with a light meter in a horizontal plane 3 ft. above the pavement or ground surface.

For mobile operations the work area shall be defined as an area 9 m (25ft) in front of and behind moving equipment.

For stationary operations the work area shall consist of the entire area where work operations are being performed.

Glare Control: All provided lighting shall be designed and operated so as to avoid glare that interferes with traffic on the roadway, workers or inspection personnel. Lighting devices meeting these requirements include:

- Large point source lighting with diffuse optics with the luminaries placed at a height between 12 and 14 feet above the roadway. Large point source lighting with diffuse optics shall be defined as large globe type fixtures with frosted or semi frosted (white in color) globes.
- Tower type stadium lighting or spot lights where the lights are aimed downward at the roadway surface and rotated outward no greater than 30 degrees from nadir (straight down).

Glare requirements also apply to flagger lighting.

Light Trespass: Lighting shall be provided and maintained so as not to cause annoyance for residences adjoining the worksite. If any complaints are received by the Engineer and/or the Contractor from residences adjoining the worksite, the Contractor shall respond immediately and modify lighting arrangement or add any necessary hardware to shield light trespass to adjoining properties. These modifications should not affect the Contractor's compliance with other requirements in this specification.

Lighting Equipment: All lighting equipment shall be furnished as required and retained by the Contractor after the work is completed. Material and/or equipment shall be in good operating condition. Before nighttime operations may begin all required lighting equipment and/or materials must be ready for operation to the satisfaction of the Engineer. Lighting shall be provided and maintained in conformity with the requirements of both the National Electrical Code (NEC) and the National Electrical Safety Code (NESC), and any applicable safety and design codes.

The Contractor shall provide sufficient fuel, spare lamps, generators, and personnel qualified to operate the lights to assure that they will be maintained in operation during night work. The Contractor shall provide backup lighting to replace failed lights and equipment during night work. The backup equipment shall be on the project and available for use at all times during night work.

Requirements for Mobile Operations:

Milling and Paving.

To provide the required lighting levels, the contractor shall mount a minimum of one large point source light on each piece of mobile construction equipment used in the construction zone. This would include the material transfer device, bituminous paving machine, bituminous rollers, milling machine, and any broom used in the milling process. Trucks used to transport materials and personnel, shall be excluded from this lighting requirement.

The additional light fixtures shall be mounted on construction equipment in a way that does not obstruct the sight of the equipment operator. The contractor shall not operate the standard headlights on the construction equipment when in the work zone.

Patching Operations

The contractor shall be required to provide the required lighting levels at each patching location where active work is being performed.

Striping, Raised Pavement Marker Removal/Installation and other Pavement Marking Operations

The striping truck shall use its normal headlights during the marking operations. Truck mounted attenuators with arrow boards used in this operation will not be required to have additional lighting. Additional lighting may be used as necessary for the operator to perform the pavement striping function.

For raised pavement marker removal and installation and other pavement marking operations, where workers are on foot outside the vehicle the required lighting levels shall be provided.

Installation and Removal of Work Zone Traffic Control Signs and Devices

Any truck used during the installation and removal of work zone traffic control devices shall have additional lighting to provide the required lighting levels.

Materials Testing and Construction Inspection Personnel

A portable lighting system meeting the requirements of this specification shall also be provided for the person performing material testing and straightedge or other smoothness test.

The lighting levels shall be 54 lux (5fc) for a distance of 15 ft. in front and back of this individual.

Other Mobile Operations

For other mobile operations, a general guide shall be to provide the required lighting levels at any location where workers are on foot outside the vehicle working.

Requirements for Stationary Operations For stationary operations the contractor shall use lighting sources which meet the required specifications for General Requirements; Lighting Levels; Glare Control; Light Trespass; and Lighting Equipment.

Inspection: The Engineer and the Contractor shall have an on-site, after dark, meeting to inspect the conformity of provided lighting conditions on site to this specification. No work shall be permitted until all requirements are met. At any time during the course of nighttime work, should the lighting be deemed inadequate by the Engineer, the work shall be halted until adequate lighting is provided. This suspension of work shall be at no additional cost to the Department and the Contractor shall receive no time extension to complete the contract work.

Basis Of Payment: This work will not be paid for separately.

LINEAR DELINEATION PANELS

This work consists of furnishing and the installation of linear delineation panels as directed by the Engineer and as herein specified.

Two (2) panels shall be placed on each side of each section of temporary concrete barrier facing traffic. These panels shall be installed 6 inches down from the top. These panels shall be alternating white and fluorescent orange and separated 18 inches apart and centered horizontally on each section of barrier wall. These panels shall be used in lieu of the Type C Crystal colored reflectors shown on Standard 704001.

Panels shall also be placed on each new or existing permanent concrete barrier median wall or concrete parapet wall 6 inches down from the top and shall remain in place after the project has been completed. These panels shall be white or yellow depending on location as directed by the Engineer and spaced at 50 feet centers with them centered horizontally. These panels shall be used in lieu of the typical reflector markers shown on Standard 635011.

Each panel shall not be less than 34 inches in length and 6.00 inches in width. The panels shall be constructed of cube-corner retroreflective material in standard highway colors permanently bonded to an aluminum substrate. The lateral edges of each panel shall be hemmed. The panel assembly shall have a repeating raised lateral ridge every 2.25 inches. Each ridge shall be 0.34 inches high with a 45° profile and a 0.28 inch radius top. Each panel shall be attached/adhered to as per the manufactures specifications and/or recommendations.

Daytime color requirements shall be determined from measurement of the retroreflective sheeting applied to aluminum test panels. Daytime color shall be measured instrumentally using a spectrophotometer employing annular 45/0 (or equivalent 0/45) illuminating and viewing geometry. Measurements shall be made in accordance with ASTM E1164 for ordinary colors or ASTM E2153 for fluorescent colors.

Chromaticity coordinates shall be calculated for CIE Illuminant D65 and the CIE 1931 (2o) Standard Colorimetric Observer in accordance with ASTM E308 for ordinary colors or ASTM E2152 for fluorescent colors.

Chromaticity Limits for White

	x	y	x	y	x	y	x	y	Limit Y (%)	
									Min	Max
White	0.303	0.287	0.368	0.353	0.340	0.380	0.274	0.316	40	-

Chromaticity Limits for Fluorescent Orange

	x	y	x	y	x	y	x	y	Total Luminance Factor Y (%)
									Min
Fluor. Orange	0.595	0.351	0.645	0.355	0.583	0.416	0.542	0.403	30

The Linear Delineation Panels will not be paid for separately but shall be considered included in the others items of traffic control or work.

TRAFFIC CONTROL FOR ROAD CLOSURE

This work consists of furnishing, installation, maintenance, and removal of all traffic control devices required for the closure of the Frontage Roads during construction of this project as shown on the plans, as directed by the Engineer, and as herein specified,

Full road closure will be required to all traffic for areas to the west of the mainline roadways. Access to local traffic will be required to areas along Frontage Road 2 and areas to the private residence to the south. Traffic Control and Protection required shall conform to Highway Standard Drawings BLR-21 and BLR-22.

This work will be paid for at the contract unit price per lump sum for TRAFFIC CONTROL FOR ROAD CLOSURE, as herein specified.

TRAFFIC CONTROL AND PROTECTION (DETOUR 1)

This work consists of furnishing, installation, maintenance, and removal of traffic control and protection, including temporary signing, required for the closure of Ramp F during stage construction operations for this project as shown on the plans, as directed by the Engineer, in accordance with the applicable portions of the Standard Specifications, and as herein specified.

Traffic control and protection required for this item is depicted on the Maintenance of Traffic Plans for the Ramp F Detour in Set 2 and 3 of 3 as shown on the plans.

This work will be paid for at the contract lump sum price for TRAFFIC CONTROL AND PROTECTION, (DETOUR 1), as herein specified.

TRAFFIC CONTROL AND PROTECTION, (SPECIAL)

This work consists of furnishing, installation, maintenance, and removal of traffic control and protection required for stage construction operations during construction of this project as shown on the plans, as directed by the Engineer, in accordance with the applicable portions of the Standard Specifications, and as herein specified.

Traffic control devices under this item are all posts or supports, signs, drums, barricades, temporary signing, temporary pavement marking and reflectors, temporary width restriction signing, temporary marking shields, and all necessary and collateral traffic control and protection measures required to perform traffic control and protection as shown on the maintenance of traffic plans, the Sequence of Construction, and as herein specified.

References to and application of Highway Standard Drawings to be used in conjunction with the traffic control and protection on the Maintenance of Traffic plans will not be paid for separately and shall be considered as included the cost of traffic control and protection as herein specified.

Existing pavement markings that are in conflict with stage construction operations for this project shall be removed as directed by the Engineer and in accordance with Section 783 of the Standard Specifications except that payment will not be made separately for this item of work, but considered as included in the costs for Traffic Control and Protection as herein specified.

Temporary concrete barriers and temporary impact attenuators will be paid for separately in accordance with Sections 701 and 704 of the Standard Specifications.

The Contractors attention is drawn to the fact that requirements have been included elsewhere in these provisions for additional traffic control protection and traffic control devices and are incorporated in this special provision by reference.

References to and application of Highway Standard Drawings for Traffic Control and Protection during roadway resurfacing operations as shown on the plans will be paid for separately as specified in Section 701 of the Standard Specifications.

Traffic control and protection as herein specified will be paid for at the contract lump sum price for TRAFFIC CONTROL AND PROTECTION, (SPECIAL) which price shall be payment in full and no additional payment will be allowed.

WET REFLECTIVE TEMPORARY PAVEMENT MARKING TAPE, TYPE III

This work consists of furnishing, installation, maintenance, and removal of temporary pavement marking as shown on the plans, as directed by the Engineer, and in accordance with Sections 703 and 1095.06 of the Standard Specifications except as herein specified.

Temporary pavement marking tape to be installed under this item is associated with stage construction operations for the reconstruction of the mainline roadways and ramps. The tape shall retain its reflective properties when submerged in water. The tape will vary in width as shown on the plans and includes temporary pavement marking shields as specified elsewhere in these provisions.

This work will not be paid for separately but considered as included in the lump sum price for TRAFFIC CONTROL AND PROTECTION (SPECIAL).

WET REFLECTIVE TEMPORARY TAPE, TYPE III, INTERSTATE SHIELD

This work shall conform to the requirements of Sections 703 and 1095.06 of the Standard Specifications except the tape shall retain its reflective properties when submerged in water. The shield shall be 15 feet tall by 6 feet wide (4" stroke).

Basis of Payment: This work will not be paid for separately but considered as included in the lump sum price for TRAFFIC CONTROL AND PROTECTION, (SPECIAL).

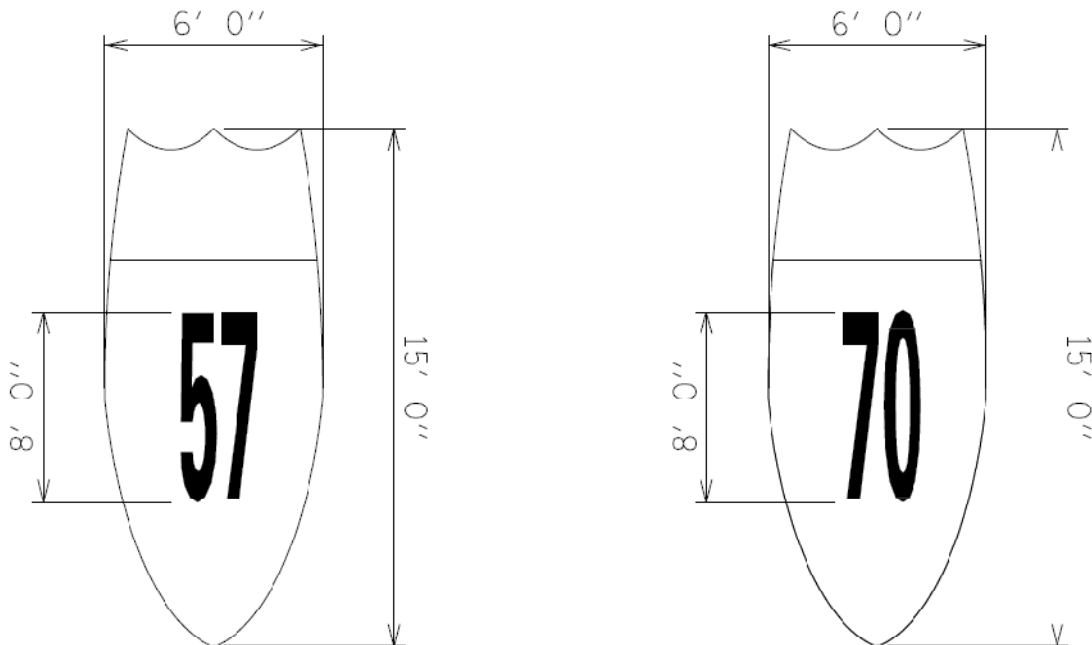

PAVEMENT MARKING GROOVING

Effective: July 31, 2009

Description. This work shall consist of the grooving of an existing pavement surface in preparation for the application recessed pavement marking lines.

Equipment. The grooving equipment shall be equipped with a free-floating cutting or grinding head. The grinding or cutting head shall be equipped with diamond saw blades, steel star cutters and/or carbide tipped star cutters. A grinder head configuration may be used on hot-mix asphalt (HMA) surfaces to achieve a rough surface texture in the bottom of the groove. Diamond saw blades shall be used on the cutting head when a smooth surface in the bottom of the groove is required by the Engineer, or contract specifications, or pavement marking material manufacturer's recommendations.

CONSTRUCTION REQUIREMENTS

Pavement Grooving Methods. The grooves for recessed pavement markings shall be constructed using the following methods.

- a) Wet Saw Blade Operation. When water is required or used to cool the saw blades, such as during a continuous edge line grooving operation, the groove shall be flushed with high pressure water immediately following the cut to avoid build up and hardening of slurry in the groove. The pavement surface shall be allowed to dry for 24 hours prior to the application of the pavement markings following a wet saw blade operation.
- b) Dry Saw Blade Operation. If the grooving is done with dry saw blades, the groove shall be flushed with high-pressure air to remove debris and dust generated during the cutting operation.

Pavement Grooving. Grooves shall be cut into the pavement prior to the application of the pavement marking. The grooves shall be cut such that the width is 1 in. (25 mm) wider than that of the line to be placed. Grooves for letters and symbols shall be cut in a shape so that the entire marking will fit. The position of the edge of the grooves shall be a minimum of 2 in. (50 mm) from the edge of concrete joints or HMA paving seams along edge or centerlines. The depth of the groove shall not be less than the manufacturer's recommendations for the marking material specified, but shall be installed to a minimum depth of 100 mils (2.54 mm) +/- 10 mils for pavement marking tapes and 40 mils (1.02 mm) +/- 10 mils for liquid markings.

On new HMA surfaces the Engineer shall determine if the new HMA has achieved the necessary strength and hardness to support grooving prior to the start of a grooving operation. Some HMA mixes may require 14 or more days to achieve adequate hardness to support a grooving operation. On existing HMA surfaces some existing HMA pavements may not be strong enough to support a grooving operation. For existing HMA pavements the Engineer shall determine if the existing HMA has the necessary strength and hardness to support grooving prior to the start of a grooving operation.

Cleaning. Immediately prior to the application of the pavement markings the groove shall be cleaned with high-pressure air blast.

Method of Measurement. This work will be measured for payment in place, in linear feet (meter) of the pavement marking lines applied and accepted, for the groove width specified.

Grooving for letters, numbers and symbols will be measured in square feet (square meters) as specified in the plans.

Basis of Payment. This work will be paid for at the contract unit price per foot (meter) for PAVEMENT MARKING GROOVING of the groove width specified, and per square foot (square meter) for PAVEMENT MARKING GROOVING, for letters, numbers and symbols, of the type specified.

URETHANE PAVEMENT MARKING

Effective March 25, 2005

Description: This work shall consist of furnishing and applying a reflectorized modified urethane, plural component, durable liquid pavement marking lines, sizes and colors as shown on the plans.

Materials: All materials shall meet the following specifications:

- (a) Modified Urethane Marking: The modified urethane pavement marking material shall consist of a homogeneous blend of modified urethane resins and pigments designed to provide a simple volumetric mixing ratio of two components (must be two volumes of Part A to one volume of Part B). No volatile solvent or fillers will be allowed.
- (b) Pigmentation: The pigment content by weight of Component A shall be determined by low temperature ashing according to ASTM D 3723. The pigment content shall not vary more than plus or minus two percent from the pigment content of the original qualified paint.

White Pigment shall be Titanium Dioxide meeting ASTM D 476 Type II, Rutile.

Yellow Pigment shall be Organic Yellow and contain no heavy metals.

- (c) Environmental: Upon heating to application temperature, the material shall not exude fumes, which are toxic or injurious to persons or property when handled according to manufacturer specifications. The modified urethane pavement marking material compositions shall not contain free isocyanate functionality.
- (d) Daylight Reflectance: The daylight directional reflectance of the cured modified urethane material (without reflective media) shall be a minimum of 80 percent (white) and 50 percent (yellow) relative to magnesium oxide when tested using a color spectrophotometer with a 45 degree circumferential / zero degrees geometry, illuminant C, and two degrees observer angle. The color instrument shall measure the visible spectrum from 380 to 720 nm with a wavelength measurement interval and spectral bandpass of 10 nm. In addition, the color of the yellow modified urethane shall visually match Color Number 33538 of Federal Standard 595a with chromaticity limits as follows:

x	0.490	0.475	0.485	0.539
y	0.470	0.438	0.425	0.456

- (e) **Weathering Resistance:** The modified urethane, when mixed in the proper ratio and applied at 0.35 to 0.41 mm (14 to 16 mils) wet film thickness to an aluminum alloy panel (Federal Test Std. No. 141, Method 2013) and allowed to cure for 72 hours at room temperature, shall be subjected to accelerated weathering for 75 hours. The accelerated weathering shall be completed by using the light and water exposure apparatus (fluorescent UV – condensation type) and tested according to ASTM G 53. The cycle shall consist of four hours UV exposure at 50 °C (122 °F) and four hours of condensation at 40 °C (104 °F). UVB 313 bulbs shall be used. At the end of the exposure period, the material shall show no substantial change in color or gloss.
- (f) **Drying Time:** The modified urethane material, when mixed in the proper ratio and applied at 0.35 to 0.41 mm (14 to 16 mils) wet film thickness and with the proper saturation of glass spheres, shall exhibit a no-tracking time of three minutes or less when tested according to ASTM D 711.
- (g) **Adhesion:** The catalyzed modified urethane pavement marking materials when applied to a 100 x 100 x 50 mm (4 x 4 x2 in) concrete block shall have a degree of adhesion which results in a 100 percent concrete failure in the performance of this test. The concrete block shall be brushed on one side and have a minimum strength of 24,100 kPa (3,500 psi). A 50 mm (2 in) square film of the mixed modified urethane shall be applied to the brushed surface and allowed to cure for 72 hours at room temperature. A 50 mm (2 in) square cube shall be affixed to the surface of the modified urethane by means of an epoxy glue. After the glue has cured for 24 hours, the modified urethane specimen shall be placed on a dynamic testing machine in such a fashion so that the specimen block is in a fixed position and the 50 mm (2 in) cube (glued to the modified urethane surface) is attached to the dynamometer head. Direct upward pressure shall be slowly applied until the modified urethane system fails. The location of the break and the amount of concrete failure shall be recorded.
- (h) **Hardness:** The modified urethane marking materials, when tested according to ASTM D-2240, shall have a Shore D Hardness greater than 75. Films shall be cast on a rigid substrate at 0.35 to 0.41 mm (14 to 16 mils) in thickness and allowed to cure at room temperature for 72 hours before testing.
- (i) **Abrasion:** The abrasion resistance shall be evaluated on a Taber Abrader with a 1,000 gram load and CS-17 wheels. The duration of test shall be 1,000 cycles. The wear index shall be calculated based on ASTM test method D-4060 and the wear index for the catalyzed material shall not be more than 80. The tests shall be run on cured samples of modified urethane material which have been applied at a film thickness of 0.35 to 0.41 (14 to 16 mils) to code S-16 stainless steel plates. The films shall be allowed to cure at room temperature for at least 72 hours and not more than 96 hours before testing.

- (j) Tensile: When tested according to ASTM D-638, the modified urethane pavement marking materials shall have an average tensile strength of not less than 6,000 pounds per square inch. The Type IV Specimens shall be pulled at a rate of ¼” per minute by a suitable dynamic testing machine. The samples shall be allowed to cure at 75 °F± 2°F for a minimum of 24 hours and a maximum of 72 hours prior to performing the indicated tests.
- (k) Compressive Strength: When tested according to ASTM D-695, the catalyzed modified urethane pavement marking materials shall have a compressive strength of not less than 12,000 pounds per square inch. The cast sample shall be conditioned at 75°F± 2°F for a minimum of 72 hours before performing the indicated tests. The rate of compression of these samples shall be no more than ¼”per minute.
- (l) Glass Spheres: The glass spheres shall meet the requirements of Article 1095.04(m) and Article 1095.07 of the Standard Specifications for first drop and second drop glass beads.
- (m) The material shall be shipped to the job site in substantial containers and shall be plainly marked with the manufacturer’s name and address; the name and color of the material, date of manufacture and batch number.
- (n) Prior to approval and use of the modified urethane pavement marking materials, the manufacturer shall submit a notarized certification of an independent laboratory, together with the results of all tests, stating these materials meet the requirements as set forth herein. The certification test report shall state the lot tested, manufacturer’s name, brand name of modified urethane and date of manufacture. The certification shall be accompanied by one half-liter (one-pint) samples each of Part A and Part B. Samples shall be sent in the appropriate volumes for complete mixing of Part A and Part B.

After approval by the Department, certification by the modified urethane manufacturer shall be submitted for each batch used. New independent laboratory certified test results and samples for testing by the Department shall be submitted any time the manufacturing process or paint formulation is changed. All costs of testing (other than tests conducted by the Department) shall be borne by the manufacturer.
- (o) Acceptance samples shall consist of one half-liter (one-pint) samples of Part A and Part B, of each lot of paint. Samples shall be sent in the appropriate volumes for complete mixing of Part A and Part B. The samples shall be submitted to the Department for testing, together with a manufacturer’s certification. The certification shall state the formulation for the lot represented is essentially identical to that used for qualification testing. All, acceptance samples shall be taken by a representative of the Illinois Department of Transportation. The modified urethane pavement marking materials shall not be used until tests are completed and they have met the requirements as set forth herein.
- (p) The manufacturer shall retain the test sample for a minimum of 18 months.

APPLICATION EQUIPMENT

The modified urethane pavement marking compounds shall be applied through equipment specifically designed to precisely meter the two components in the ratio of 2:1 and approved by the manufacturer of the material. This equipment shall produce the required amount of heat at the mixing head and gun tip and maintain those temperatures within the tolerances specified. This equipment shall also have as an integral part of the gun carriage, a high pressure air spray capable of cleaning the pavement immediately prior to the marking application.

The equipment shall be capable of spraying both yellow and white urethane, according to the manufacturer's recommended proportions and be mounted on a truck of sufficient size and stability with an adequate power source to produce lines of uniform dimensions and prevent application failure. The truck shall have at least two urethane tanks each of 415 L (110 gal) minimum capacity and shall be equipped with hydraulic systems. It shall be capable of placing stripes on the left and right sides and placing two lines on a three-line system simultaneously with either line in a solid or intermittent pattern, in yellow or white, and applying glass beads by the double drop pressurized bead system. The system shall apply both the first drop glass beads and the second drop glass beads at a rate of 1.2 kg per L (10 lb/gal). The equipment shall be equipped with pressure gauges for each proportioning pump. All guns shall be in full view of operators at all times. The equipment shall have a metering device to register the accumulated installed quantities for each gun, each day. Each vehicle shall include at least one operator who shall be a technical expert in equipment operations and urethane application techniques. Certification of equipment shall be provided at the preconstruction conference.

APPLICATION

The pavement shall be cleaned by a method approved by the Engineer to remove all dirt, grease, glaze or any other material that would reduce the adhesion of the markings with minimum or no damage to the pavement. New PCC pavements shall be blast-cleaned to remove all curing compounds.

Markings shall be applied to the cleaned surfaces on the same calendar day. If this cannot be accomplished, the surface shall be re-cleaned prior to applying the markings. Existing pavement markings shall be at least 90 percent removed. No markings shall be applied until the Engineer approves the cleaning.

Widths, lengths and shapes of the cleaned surface shall be prepared wider than the modified urethane pavement marking material to be applied, such that a prepared area is on all sides of the urethane pavement marking material after application.

New asphalt concrete and seal coated surfaces shall be in place a minimum of two weeks prior to marking applications.

The cleaning operation shall be a continuous moving operation process with minimum interruption to traffic.

The pavement markings shall be applied to the cleaned road surface, during conditions of dry weather and subsequently dry pavement surfaces at a minimum uniform wet thickness of 20 mils in accordance with the manufacturer's installation instructions and at the widths and patterns shown on the contract plans.

The application and combination of reflective media (glass beads and/or reflective elements) shall be applied at a rate specified by the manufacturer. At the time of installation the pavement surface temperature shall be 40 ° F and rising and the ambient temperature shall be 35° F and rising. The pavement surface temperature and the ambient temperatures shall be determined and documented before the start of each of marking operation. The pavement markings shall not be applied if the pavement shows any visible signs of moisture or it is anticipated that damage causing moisture, such as rain showers, may occur during the installation and curing periods. The Engineer shall determine the atmospheric conditions and pavement surface conditions that produce satisfactory results.

Unless directed by the Engineer, lines shall not be laid directly over a longitudinal crack or joint. The edge of the center line or lane line shall be offset a minimum distance of 50 mm (2 inches) from a longitudinal crack or joint. Edge lines shall be approximately 50 mm (2 inches) from the edge of pavement. The finished center and lane lines shall be straight, with the lateral deviation of any 3 meter (10-foot) line not to exceed 25 mm (1 inch).

Notification:

The Contractor shall notify the Engineer 72 hours prior to the placement of the markings in order that an inspector can be present during the operation. At the time of this notification, the Contractor shall indicate the manufacturer and lot numbers of urethane and reflective media that he intends to use. The Engineer will ensure that the approved lot numbers appear on the material package. Failure to comply with this provision may be cause for rejection.

The Contractor shall provide an accurate temperature-measuring device(s) that shall be capable of measuring the pavement temperature prior to application of the material, the material temperature at the gun tip and the material temperature prior to mixing.

Inspection:

The urethane pavement markings will be inspected following installation, but no later than December 15, and inspected following a winter performance period that extends 180 days from December 15 in accordance with the provisions of Article 780.10 of the Standard Specification for Road and Bridge Construction.

Method of Measurement:

The lines will be measured for payment in feet of urethane pavement marking lines applied and accepted, measured in place. Double yellow lines will be measured as two separate lines. Words and symbols shall conform to the size and dimensions specified in the Manual on Uniform Traffic Control Devices and Standard 780001 and will be measured based on total areas indicated in table 1 or as specified in the plans.

Basis of Payment:

This work will be paid for at the contract unit prices per foot of applied line for URETHANE PAVEMENT MARKING - LINE 4, 5, 6, 8, 12, 24 inches or per square foot URETHANE PAVEMENT MARKING – LETTERS AND SYMBOLS measured as specified herein.

PREFORMED THERMOPLASTIC PAVEMENT MARKING SHIELD

Material: Must be composed of an ester modified rosin resistant to degradation by motor fuels, lubricants, etc. in conjunction with aggregates, pigments, binders, abrasives, and glass beads which have been factory produced as a finished product, and meets the requirements of the current edition of the Manual on Uniform Traffic Control Devices for Streets and Highways. The thermoplastic material conforms to AASHTO designation M249-79 (98), with the exception of the relevant differences due to the material being supplied in a preformed state.

Graded Glass Beads:

The material must contain a minimum of thirty percent (30%) intermixed graded glass beads by weight. The intermixed beads shall be clear and transparent. Not more than twenty percent (20%) consists of irregular fused spheroids, or silica. The index of refraction shall not be less than 1.50.

The material must have factory applied coated surface beads and abrasives in addition to the intermixed beads at a rate of ½ lb. ($\pm 20\%$) per 11 sq. ft. The surface beads and abrasives must be applied so that every other shaped portion contains glass beads, or abrasives with a minimum hardness of 7 (Mohs scale). These factory applied coated surface beads shall have the following specifications:

- 1) Minimum 80% rounds
- 2) Minimum refractive index of 1.5
- 3) Minimum SiO₂ Content of 70%;
- 4) Maximum iron content of 0.1%;

Size Gradation		Retained, %	Passing, %
US Mesh	um		
12	1700	0 - 2%	98 - 100%
14	1400	0 - 6%	94 - 100%
16	1180	1 - 21%	79 - 99%
18	1000	28 - 62%	38 - 72%
20	850	62 - 71%	29 - 38%
30	600	67 - 77%	23-33%
50	300	86 - 95%	5 - 14%
80	200	97 - 100%	0 - 3%

Pigments:

White: The material shall be manufactured with sufficient titanium dioxide pigment to meet FHWA Docket No. FHWA-99-6190 Table 5 and Table 6 as revised and corrected.

Red, Blue, and Yellow: The material shall be manufactured with sufficient pigment to meet FHWA Docket No. FHWA-99-6190 Table 5 and Table 6 as revised and corrected. The yellow pigment must be organic and must be heavy-metal free.

Other Colors: The pigment must be heavy-metal free.

Heating indicators: The top surface of the material (same side as the factory applied surface beads) shall have regularly spaced indents. These indents shall act as a visual cue during application that the material has reached a molten state so satisfactory adhesion and proper bead embedment has been achieved and a post-application visual cue that the installation procedures have been followed.

Skid Resistance: The surface of the preformed retroreflective marking materials, wherein every other shaped portion contains glass beads, or abrasives with a minimum hardness of 7 (Mohs scale), shall upon applications provide a minimum skid resistance value of 60 BPN when tested according to ASTM: E 303.

Thickness: The material must be supplied at a minimum thickness of 90 mils (2.29 mm) or 125 mils (3.15 mm).

Retroreflectivity: The preformed retroreflective marking material upon application shall exhibit adequate and uniform nighttime retroreflectivity. The marking materials shall have the following retroreflectivity as measured using a Delta LTL 2000 or LTL-X Retroreflectometer:

White Preformed reflective marking materials-minimum of $275 \text{ mcd}\cdot\text{m}^{-2}\cdot\text{lx}^{-1}$

Note: Initial retroreflection and skid resistance are affected by the amount of heat applied during installation. When ambient temperatures are such that greater amounts of heat are required for proper installation, initial retroreflection and skid resistance levels may be affected.

Environmental Resistance: The material must be resistant to deterioration due to exposure to sunlight, water, salt or adverse weather conditions and impervious to oil and gasoline.

Abrasives: The material must have factory applied surface abrasives, wherein every other shaped portion contains glass beads, or abrasives with a minimum hardness of 7 (Mohs scale).

Application:

Asphalt and Concrete: The material shall be applied using the propane torch method recommended by the manufacturer. The material must be able to be applied without minimum requirements for ambient and road temperatures and without any preheating of the pavement to a specific temperature. The material must be able to be applied without the use of a thermometer. The pavement shall be clean, dry and free of debris. A compatible primer sealer must be applied before application to assure proper adhesion. Supplier must enclose application instructions with each box/package.

Method of Measurement: This item will be measured by each.

Basis of Payment: This work will be paid for at the contract unit price per each for PREFORMED THERMOPLASTIC PAVEMENT MARKING SHIELD.

TRAFFIC COUNTER

This work consists of furnishing components of traffic counter systems at locations shown on the plans, as directed by the Engineer, and as herein specified.

Generally the traffic counter system is installed on break-away wide flange beam steel sign supports and foundations. For this project the components furnished under this contract will be installed by IDOT forces from the Office of Planning and Programming Data Management Lab. The installed components will complete the Traffic Counter system as herein specified. All necessary hardware, bolts, pipes and conduits necessary to install the components will be provided by IDOT.

The components to be furnished under this item are as follows:

- Data Collection Systems
- Wireless Modems
- Dual Band Cellular/ PCS Antennas
- Cabinets
- Solar Panels
- 3' Antenna Cables

Components to be furnished under this item shall conform to the following manufacturer's specification or an approved equivalent:

<u>COMPONENT</u>	<u>Distributor</u>
TIRTL Traffic Counter	Control Specialists, Inc,
TIRTL Cabinet	Control Specialists, Inc
Airlink Raven XT EVDO Rev A VZW Wireless Modem P/N V2221-VD	CDS Office Systems
Antenex Phantom Dual Band Cellular/PCS Antenna 3db gain. P/N RF-ART18305P/281	CDS Office Systems
Antenna Cable 3' SMA Male to N Male RG-58 Jumper	CDS Office Systems

The number of components necessary to complete each installation is shown on the plans. The components shall be delivered to the site and stored at a location directed by the Engineer.

The wide flange beam break-away sign supports and foundation will be paid for separately and included for payment as STRUCTURAL STEEL SIGN SUPPORT – BREAKAWAY and as CONCRETE FOUNDATIONS as specified in Sections 727 and 734 of the Standard Specifications.

Full manufacturer's specifications of the components to be furnished under this item shall be approved in writing prior to ordering of components. Warranty information shall be provided to the Engineer at the time of delivery of the components.

Contact Information for Office of Planning and Programming Data Management Lab is Mr. Ramon Taylor, 126 E. Ash Street, Springfield, IL. Phone 217.782.2065

Furnishing of the components necessary to complete the traffic counter systems will be paid for at the contract unit price each for TRAFFIC COUNTER and shall include all components necessary to complete each installation as herein specified.

PVC CONDUIT

This work shall consist of furnishing and installing a conduit of the type and size specified, in accordance with Section 810 of the Standard Specifications except as described herein.

The substitution of Polyethylene duct in place of PVC conduit, augured or in trench, of the size specified in the plans is permitted with no change in compensation of this item.

The term augured shall cover both the pushed and bored method of installing the conduit. Because of differences in the equipment and techniques, the contractor may use either method to install the conduit for the item AUGERED.

If the contractor chooses to install conduit runs designated as trenched in the plans by auguring, payment shall be at the contract unit price per FOOT for CONDUIT IN TRENCH of the size specified along with trench and backfill for this work.

When PVC Conduit is required to be spliced to steel conduit sections, a heavy wall set screw connector with PVC female adapter shall be installed and sealed by duct seal and plastic tape.

A ¼" polypropylene pull rope shall be installed in all conduit runs exceeding 20 feet. A minimum of 2 feet of rope shall be provided at each end of a conduit run.

This work will be paid for at the contract unit price per FOOT for PVC CONDUIT, of the size and type specified. Trench and backfill when required will be paid for separately.

LUMINAIRE TESTING

Description: This work shall consist of independent laboratory testing to verify Roadway Luminaries are manufactured and furnished to IDOT according to Section 821 of the Standard Specifications and as modified herein.

Testing: Luminaries shall be tested at a properly accredited and fully certified laboratory approved for each of the required tests. All costs associated with luminaries testing shall be included in the bid price of the luminaries.

Each luminaire type used on the project shall be tested, unless noted otherwise. In addition, each luminaire wattage and distribution within a given luminaire type shall be tested. Only one luminaire for each type, wattage, and distribution shall be tested except, one additional luminaire shall be tested for each quantity of 50 luminaires supplied to the project.

The Contractor shall propose, for approval by the Engineer, testing at either the luminaire manufacturer's test laboratory or an independent test laboratory. The qualifications of the laboratory to perform each of the required tests must be furnished to the Engineer at the time the request is made to select a lab.

In addition, the Contractor shall propose a qualified independent witness, for approval by the Engineer, familiar with the luminaire requirements and test procedures, to witness the required tests. The Contractor shall provide all travel costs for the independent witness to and from the test location for all required testing. The Contractor shall supply documentation to the Engineer of the independent witness' qualifications at the time of request for selection approval.

No luminaires shall be shipped for testing until the Engineer's written approval is received for the approved lab and witness. The Contractor is responsible to find a suitable independent witness and provide advanced notice for travel and testing. No extension of time will be allowed for delays incurred as a result of luminaire testing.

The independent witness shall select from the project luminaires at the manufacturer's facility or at the Contractor's storage facility, the luminaires for testing. In all cases, the selection of luminaries shall be a random selection from the entire completed lot of luminaries required for the contract. Selections from partial lots will not be allowed.

The testing performed shall include photometric and electrical testing. Photometric testing shall be according to IES recommendations and as a minimum, shall yield an isofootcandle chart, with max candela point and half candela trace indicated, an isocandela diagram, maximum plane and maximum cone plots of candela, a candlepower table (house and street side), a coefficient of utilization chart, a luminous flux distribution table, and complete calculations based on specified requirements and test results.

Electrical testing shall conform to NEMA and ANSI standards and as a minimum, shall yield a complete check of wiring connections, a ballast dielectric test, total ballast losses in watts and percent of input, a lamp volt-watt trace, regulation data, a starter test, lamp current crest factor, power factor (minimum over the design range of input voltage at nominal lamp voltage) and, a table of ballast characteristics showing input amperes, watts and power factor, output volts, amperes, watts and lamp crest factor as well as ballast losses over the range of values required to produce the lamp volt-watt trace.

The summary report and the test results shall be certified by the independent test laboratory or the independent witness, as applicable, and shall be sent by certified mail directly to the Engineer. A copy of this material shall be sent to the Contractor at the same time.

Electrical and photometric test reports shall be sent to the Engineer as part of the shop drawing approval process.

Should any of the tested luminaries of a given type, distribution, and wattage fail to satisfy the specifications and perform according to approved submittal information, the luminaire of that type, distribution, and wattage shall be unacceptable and shall be replaced. Replacement luminaries must meet the specifications and therefore, the submittal and testing process shall be repeated in its entirety.

Upon approval by the Engineer, luminaries which fail may have corrections made instead of being replaced. In the case of corrections, the Contractor shall advise the Engineer of the corrections to be made and shall request a repeat of the specified testing and, if the corrections are deemed reasonable by the Engineer, the testing process shall be repeated. The number of luminaries to be tested shall be the same quantity as originally tested. Luminaries which are not modified or corrected shall not be retested without prior approval from the Engineer.

The process of retesting (testing modified or replacement luminaries) shall be repeated until luminaries are approved for the project. Retesting, should it become necessary, shall not be grounds for additional compensation or extension of time.

Basis of Payment: This work will be paid for as part of the contract unit price each for the specific luminaire pay item to which it is associated. No separate payment will be made for luminaire testing.

LIGHTING CONTROLLER, BASE MOUNTED, 480VOLT, 100AMP

This work shall consist of furnishing and installing a lighting controller according to Section 825 of the Standard Specifications except the controller enclosure shall be 50" in height by 36" in width by 17" in depth, sized larger as needed.

This work will be paid for at the contract unit price each for LIGHTING CONTROLLER, BASE MOUNTED, 480VOLT, 100AMP.

LIGHTING CONTROLLER, BASE MOUNTED, 480VOLT, 200AMP

This work shall consist of furnishing and installing a lighting controller according to Section 825 of the Standard Specifications except the controller enclosure shall be 50" in height by 36" in width by 17" in depth, sized larger as needed.

This work will be paid for at the contract unit price each for LIGHTING CONTROLLER, BASE MOUNTED, 480VOLT, 200AMP.

SEISMIC RESTRAINERS

Description. Seismic restrainer units of the type or types shown on the plans, consists of the cable assemblies and associated materials or components. Each assembly unit and associated materials shall conform to the details shown on the plans and the requirements of these special provisions. Associated steel bumper and bracket assemblies shall conform to the requirements of Section 505 of the Standard Specifications.

Materials. The associated materials or components required for each seismic restrainer unit include the following items: cables, swaged fittings, studs, nuts, washers, elastomeric pads, cable yield indicators, and disc springs. Each seismic restrainer shall be shipped as one unit. Each item of the seismic restrainer unit shall conform to the following requirements.

Cables shall be $\frac{3}{4}$ inch (19 mm) preformed, 6 x 19, wire strand core or independent wire rope core, galvanized in accordance with Federal Specification RR_W_410D, right regular lay and manufactured of improved plow steel with a minimum breaking strength of 23 tons.

The swaged fitting shall be machined from hot-rolled bars of steel conforming to the requirements in AISI Designation: C1035, and shall be annealed, suitable for cold swaging. A lock pinhole to accommodate a $\frac{1}{4}$ " plated spring steel pin shall be drilled through the head of the swaged fitting to retain the stud in proper position. The manufacturer's identifying mark shall be stamped on the body of the swaged fitting.

The one inch (25mm) diameter stud shall be in accordance with ASTM A 449 after galvanizing. Threads shall have a Class 2A fit before galvanizing. Prior to galvanizing, a $\frac{3}{8}$ inch (9.5 mm) slot for the locking pin shall be milled in the stud end.

Nuts and washers shall conform to the sizes indicated on the existing plans and shall conform to section 1006.08 of the standard spec.

The elastomeric pads shown with the seismic restrainers shall conform to section 1083.02 of the standard spec. TFE, stainless steel sheets and structural steel is not required.

The Contractor shall furnish cable yield indicators manufactured by the following, or others, as approved by the Engineer:

Cable Moore Inc.
P.O. Box 23036
Oakland, CA 94623-0036
Phone: (510) 272-0218
Fax: (510) 272-0829

The cable yield indicators shall be machined from hot-rolled bars of steel conforming to the requirements in AISI Designation: C 1035 and shall be annealed, suitable for cold swaging. The heat number and manufacturer's identifying mark shall be stamped on the end surface of each cable yield indicator. The wall thickness of the reduced section of the cable yield indicator shall be machined by the Contractor so that the indicator yields at a load between 36 kips and 38 kips when tested in compression along the major axis at a test speed not to exceed $\frac{1}{2}$ " per minute.

The disc springs shall be made from steel conforming to the requirements in ASTM A684, Grade 1075. Galvanizing of the disc spring will not be required. The disc springs shall be cleaned and painted with a paint recommended by the manufacturer and the color coded as shown on the plans.

Unless otherwise specified steel parts shall conform to the requirements in AASHTO M183. Steel for bearing pins shall conform to the requirements in AASHTO M183 or ASTM A576 Grade 1030 (AISI 1030) and shall be other than rimmed or capped steel.

Galvanizing. All components of seismic restrainer units with the exception of the disc springs shall be galvanized in accordance with AASHTO M111 or M232 as applicable. Galvanizing of material shall be performed after fabrication. Fabrication shall include all operations such as shearing, cutting, punching, forming, drilling, milling, and bending.

Components of bolted assemblies shall be galvanized separately before assembly.

Tapping of nuts or other internally threaded parts to be used with zinc coated bolts, anchor bars or studs shall be done after galvanizing and shall conform to the requirements for threaded dimensions and over tapping allowances in ASTM A563.

Galvanized surfaces that are abraded or damaged at any time after the application of the zinc coating shall be field repaired in accordance with ASTM A780, except noted below.

Galvanized surfaces that are abraded or damaged at any time after the application of the zinc coating shall be repaired by thoroughly wire brushing the damaged areas and removing all loose and cracked coating, after which the cleaned areas shall be painted with 2 applications of unthinned zinc-rich primer (organic vehicle type) of a type approved by the Engineer. Aerosol cans shall not be used. Thickness of repair shall be not less than 3.5 mils. The Engineer will be the sole judge of the severity of damaged areas for purposes of repair or replacement.

In addition to galvanization, the following corrosion protection shall be provided:

The cables shall be fully coated with corrosion inhibiting grease and then encapsulated by a smooth, high-density polyethylene (HDPE) sheath.

The swaged fittings and portion of the adjacent sheathed cable and threaded stud shall be covered with a mastic-lined heat shrink tubing.

Cable yield indicators, washers, disc springs, nuts, and threaded studs shall be coated with a prime coat of red calcium sulphonate penetrant.

Cable yield indicators, washers, disc springs, nuts and portions of threaded studs from the outer face of the nuts to and including the end of the rods shall be coated with a finish coat of gray calcium sulphonate/alkyd.

The HDPE sheathing shall 1) have a density between 12.07 lb/ft³ and 12.33 lb/ft³ as measured in conformance with ASTM Designation: D 792, A-2, 2) have a minimum wall thickness of 0.079in, 3) have sufficient strength to prevent damage during construction operations, 4) be watertight, 5) be chemically stable without embrittlement or softening, 6) be nonreactive with concrete, steel, or corrosion inhibiting grease, and 7) be flush with the ends of the galvanized swaged fittings. Burned or damaged HDPE sheathing will be rejected.

Construction Requirements

Installation The Contractor shall be responsible for determining the required lengths of the cable assemblies.

The Contractor shall notify the Engineer, in writing at least 2 days prior to setting the bumper and bracket assemblies and tightening the cable assemblies.

All steel bracket and steel bumper assemblies shall be attached and bolted to the existing beams. The locations of bolt holes for the assemblies shall be field drilled on the existing beams.

The contact areas between the bumper / brackets and the existing beams shall be free of rust. Areas of contact on the existing beams with rust shall be cleaned and painted according to the Special Provision Cleaning and Painting Contact Areas of Existing Steel Structures.

The brackets and bumpers shall be located on the existing beams as shown in the plans. The brackets shall sit in full contact with the inside bottom flange. The bracket shall be placed to clear the existing beam's web to flange radius.

Cable yield indicators and disc springs shall be installed at the expansion ends of the existing beams.

The cable assembly unit shall conform to the installation procedure as outlined on the plans.

Once the Seismic Restrainer is installed and the nuts are set, an approved thread locking system, consisting of a cleaner, primer and anaerobic adhesive shall be applied where shown on the plans. Lubricants and foreign materials shall be removed from the threaded areas of both parts using the cleaner and small wire brush. The primer shall be applied to cover the threaded areas of both parts. The anaerobic adhesive shall be applied to fill the male threads in the area of the final position of the nut. The nut shall be installed at the location or to the torque shown on the plans, and an additional fillet of anaerobic adhesives shall be applied completely around the exposed junctions of the nut and male part.

Testing & Inspection The Contractor shall notify the Engineer, in writing, at least 2 days prior to tightening and setting of cable restrainer units.

Two certified copies of mill test reports of each manufactured length of cable shall be provided to the field Engineer.

Two certified copies of the mill test and heat treating reports of each heat of bars used for cable yield indicators shall be furnished to the Engineer.

The following materials shall be furnished to the Engineer for testing at the manufacturer's plant:

1. One sample cable assembly, consisting of a cable properly fitted with a swaged fitting and right hand thread stud at both ends, three (3) feet in total length, for each 200 cable assemblies or fraction thereof produced. In no case shall less than one sample of the cable assembly be furnished.
2. One percent of the cable yield indicators, but not fewer than 8, produced from each mill heat.

Method of Measurement. This work will be measured for payment per (each) in place. Each Seismic Restrainer unit will consist of two cable assemblies. All fabrication and erection of steel bumpers and brackets will be measured according to Section 505 of the standard spec.

Basis of Payment. Payment for the above described work, including all material, equipment, labor, and any other incidental work necessary to complete this item, will be considered completely covered by the contract unit price each for "SEISMIC RESTRAINER".

UNSOUND CONCRETE REMOVAL

Description.

This work shall consist of the satisfactory removal and disposal of all loose and deteriorated concrete from the existing bridge substructure at locations and as detailed on the plans and as directed by the Engineer.

Equipment.

The equipment used shall be subject to the approval of the Engineer and shall meet the following requirements:

- (a) Concrete Removal Equipment. Concrete removal equipment shall be according to the applicable portions of Section 1100 and the following:
 - (1) Blast Cleaning Equipment. The blast cleaning may be performed by wet sandblasting, high-pressure water blasting, shot blasting or abrasive blasting. Blast cleaning equipment shall be capable of removing rust and old concrete from exposed reinforcement bars, and shall have oil traps.
 - (2) Power-Driven Hand Tools. Power driven hand tools will be permitted including chipping hammers lighter than 15 lb. class. Hammers larger than the 15 lb. class will not be allowed. Chipping hammers shall not be operated at an angle in excess of 45 degrees measured from the surface of the slab.

Construction Requirements.

All loose, disintegrated and unsound concrete shall be removed from portions of the substructure units as shown on the plans or as designated by the Engineer. The Engineer will determine the limits of removal as the work progresses.

The Contractor shall take care not to damage reinforcement bars or expansion joint to remain in place. Any damage to reinforcement bars or expansion joints shall be corrected at the Contractor's expense. All loose reinforcement bars, as determined by the Engineer shall be cut and removed.

Care shall be exercised during concrete removal to protect the reinforcement bars and structural steel from damage. Any damage to the reinforcement bars or structural steel to remain in place shall be repaired or replaced to the satisfaction of the Engineer at the Contractor's expense.

All solids generated during construction activities shall be properly disposed of according to Article 202.03.

Basis of Payment.

This work will be paid for at the contract unit price per Square Yard for UNSOUND CONCRETE REMOVAL, which price shall include all material and labor to satisfactorily complete the work.

DRAINAGE SYSTEM

Effective: June 10, 1994

Revised: January 1, 2007

Description. This work shall consist of furnishing and installing a bridge drainage system as shown on the plans, including all piping, fittings, support brackets, inserts, bolts, and splash blocks when specified.

Material. The pipe and fittings shall be reinforced fiberglass according to ASTM D 2996 RTRP with a 30,000 psi (207 MPa) minimum short-time rupture strength hoop tensile stress. The reinforced fiberglass shall also have an apparent stiffness factor at 5 percent deflection exceeding 200 cu in.-lbf/sq. in. (22.6 cu mm-kPa) and a minimum wall thickness of 0.10 in. (2.54 mm). All pipe supports and associated hardware shall be hot dip galvanized according to AASHTO M 232 (M 232M). The fiberglass pipe and fittings furnished shall be pigmented through out, or have a resin-rich pigmented exterior coat, specifically designed for overcoating fiberglass, as recommended by the manufacturer. The color shall be as specified by the Engineer. The resin in either case shall have an ultraviolet absorber designed to prevent ultraviolet degradation. The supplier shall certify the material supplied meets or exceeds these requirements.

Design. The drainage system shall be designed as an open system with allowances for the differential expansion and contraction expected between the superstructure and the substructure to which the drainage system is attached.

Installation. All connections of pipes and fittings shown on the plans to facilitate future removal for maintenance cleanout or flushing shall be made with a threaded, gasketed coupler or a bolted gasketed flange system. Adhesive bonded joints will be permitted for runs of pipe between such connections. The end run connection shall feature a minimum nominal 6 in. (150 mm) female threaded fiberglass outlet. Straight runs may utilize a 45 degree reducing saddle bonded to the pipe. The female outlet shall be filled with a male threaded PVC plug.

Runs of pipe shall be supported at spacings not exceeding those recommended by the manufacturer of the pipe. Supports that have point contact or narrow supporting areas shall be avoided. Standard slings, clamps, clevis hangers and shoe supports designed for use with steel pipe may be used. A minimum strap width for hangers shall be 1 1/2 in. (40 mm) for all pipe under 12 in. (300 mm) in diameter and 2 in. (50 mm) for diameters 12 in. (300 mm) or greater. Straps shall have 120 degrees of contact with the pipe. Pipes supported on less than 120 degrees of contact shall have a split fiberglass pipe protective sleeve bonded in place with adhesive.

All reinforced fiberglass pipe, fittings, and expansion joints shall be handled and installed according to guidelines and procedures recommended by the manufacturer or supplier of the material.

Basis of Payment. This work will be paid for at the contract lump sum price for DRAINAGE SYSTEM.

JACK AND REMOVE EXISTING BEARINGS

Effective: April 20, 1994

Revised: January 1, 2007

Description: This work consists of furnishing all labor, tools and equipment for jacking and supporting the existing beams/slab while removing the bearing assembly. The Contractor is responsible for the complete design of the bridge lifting procedures and the materials used. The Contractor shall furnish and place all bracing, shoring, blocking, cribbing, temporary structural steel, timber, shims, wedges, hydraulic jacks, and any other materials and equipment necessary for safe and proper execution of the work. The Contractor shall remove and dispose of the bearings according to Article 501.05 of the Standard Specifications.

Construction Requirements: The Contractor shall submit details and calculations of his/her proposed jacking systems and temporary support procedures for approval by the Engineer before commencing work. At any time during the bridge raising operations, the Engineer may require the Contractor to provide additional supports or measures in order to furnish an added degree of safety. The Contractor shall provide such additional supports or measures at no additional cost to the Department. Neither added precautions nor the failure of the Engineer to order additional protection will in any way relieve the Contractor of sole responsibility for the safety of lives, equipment and structure.

- (a) Jack and Remove Existing Bearings with bridge deck in place. Jacking and cribbing under and against the existing diaphragms, if applicable, will not be allowed. The Contractor's jacking plans and procedures shall be designed and sealed by an Illinois Licensed Structural Engineer.

In all cases, traffic shall be removed from the portion of the structure to be jacked prior to and during the entire time the load is being supported by the hydraulic pressure of the jack(s). The minimum jack capacity per beam shall be as noted in the plans. Whenever possible, traffic shall be kept off that portion of the structure during the entire bearing replacement operation. The shoring or cribbing supporting the beam(s) during bearing replacement shall be designed to support the dead load plus one half of the live load and impact shown in the plans. If traffic cannot be kept off that portion of the structure during the bearing replacement then the shoring or cribbing supporting the beam(s) shall be designed to support the dead load and full live load and impact shown in the plans.

No jacking shall be allowed during the period of placement and cure time required for any concrete placed in the span(s) contributing loads to the bearings to be jacked and removed.

Jacking shall be limited to 1/8 in. (4 mm) maximum when jacking one bearing at a time. Simultaneous jacking of all beams at one support may be performed provided the maximum lift is 1/4 in. (7 mm) and the maximum differential displacement between adjacent beams is 1/8 in. (4 mm). Suitable gauges for the measurement of superstructure movement shall be furnished and installed by the Contractor.

- (b) Jack and Remove Existing Bearings when entire bridge deck is removed. Jacking and bearing removal shall be done after the removal of the existing bridge deck is complete. The Contractor's plans and procedures for the proposed jacking and cribbing system shall be designed and sealed by an Illinois Licensed Structural Engineer, unless jacking can be accomplished directly from the bearing seat under the beams or girders.

Jacking shall be limited to 1/4 in. (7 mm) maximum when jacking one beam at a time. Simultaneous jacking of all beams at one support may be performed provided the maximum lift is 3/4 in. (19 mm) and the maximum differential displacement between adjacent beams is 1/4 in. (7 mm). When staged construction is utilized, simultaneous jacking of all beams shall be limited to 1/4 in. (7 mm) unless the diaphragms at the stage line are disconnected, in which case the maximum lift is 3/4 in. (19 mm). Suitable gauges for the measurement of superstructure movement shall be furnished and installed by the Contractor.

The Contractor shall be responsible for restoring to their original condition, prior to jacking, the drainage ditches, pavement, or slopewall disturbed by the cribbing footings.

Basis of Payment: This work will be paid for at the contract unit price each for JACK AND REMOVE EXISTING BEARINGS.

CLEANING AND PAINTING CONTACT SURFACE AREAS OF EXISTING STEEL STRUCTURES

Effective: June 30, 2003

Revised: January 1, 2007

Description. This work shall consist of the surface preparation and painting of existing steel structures in areas that will be in contact with new steel.

The existing steel at primary connections (faying surfaces) shall be prepared, and primed as specified herein prior to connecting new structural steel to the existing structure.

The existing steel at secondary connections shall be prepared, and if bare metal is exposed, primed as specified herein prior to connecting new structural steel to the existing structure.

General. The existing coatings shall be assumed to contain lead and may also contain other toxic metals. Any plans that may be furnished for the work, and any dimensions or other information given regarding a structure, are only for the purpose of assisting bidders in determining the type and location of steel to be cleaned and painted. It is the responsibility of the Contractor to verify this information and the accuracy of the information provided shall in no way affect the price bid for structural steel.

Materials. The Bureau of Materials and Physical Research has established a list of all products that have met preliminary requirements. Each batch of material must be tested and approved before use.

The paint materials shall meet the requirements of the following articles of the Standard Specification:

<u>Item</u>	<u>Article</u>
a) Organic Zinc Rich Primer (Note 1)	
b) Aluminum Epoxy Mastic	1008.03

Note 1: These material requirements shall be according to the Special Provision for the Organic Zinc-Rich Paint System.

Submittals:

- a) Manufacturer's application instructions and product data sheets. Copies of the paint manufacturer's application instructions and product data sheets shall be furnished to the Engineer at the field site before steel cleaning begins.
- b) Waste Management Plan. The Waste Management Plan shall address all aspects of waste handling, storage, testing, hauling and disposal. Include the names, addresses, and a contact person for the proposed licensed waste haulers and disposal facilities. Submit the name and qualifications of the laboratory proposed for Toxicity Characteristic Leaching Procedure (TCLP) analysis.
- c) Quality Control (QC) Program. The QC Program shall identify the following; the instrumentation that will be used, a schedule of required measurements and observations, procedures for correcting unacceptable work, and procedures for improving surface preparation and painting quality as a result of quality control findings.

Construction Requirements. The Contractor shall perform first line, in process QC inspections. The Contractor shall implement the submitted and accepted QC Program to insure that the work accomplished complies with these specifications. The designated Quality Control inspector shall be onsite full time during any operations that affect the quality of the coating system (e.g., surface preparation, coating mixing and application, and evaluations between coats and upon completion of the work). The Contractor shall provide artificial lighting in areas where natural light is inadequate, as determined by the Engineer, to allow proper cleaning, inspection, and painting. Illumination for inspection shall be at least 30 foot candles (325 LUX). Illumination for cleaning and priming, including the working platforms, access, and entryways shall be at least 20 foot candles (215 LUX).

The Contractor shall be responsible for any damage caused to persons, vehicles, or property, except as indemnified by the Response Action Contractor Indemnification Act. Whenever the intended purposes of the protective devices are not being accomplished, as determined by the Engineer, work shall be immediately suspended until corrections are made. Painted surfaces damaged by any Contractor's operation shall be removed and repainted, as directed by the Engineer, at the Contractor's expense.

Weather Conditions. Surfaces to be primed after cleaning shall remain free of moisture and other contaminants. The Contractor shall control his/her operations to insure that dust, dirt, or moisture does not come in contact with surfaces cleaned prior to painting. Surfaces painted shall be protected until the coating is sufficiently cured to protect itself from damage.

Restrictions on ambient conditions shall be as per the coating manufacturer's written specifications.

Surface Preparation: Prior to making connections or painting, all loose abrasives, paint, and residue shall be contained, collected, removed from the surface area and properly disposed of as specified later in this specification.

Painted surfaces of new steel damaged by abrasive blasting or by the Contractor's operations shall be repainted, as directed by the Engineer, at the Contractor's expense.

- a) **Primary Connections.** Primary connections shall be defined as faying (contact) surfaces of high-strength bolted splices in main, load-carrying members, end diaphragms, end cross-frames, and other areas specifically noted in plans (such as cross-frame connections on curved girders, etc.). These will typically occur where existing splices are replaced or new splices are added.

The surfaces of existing steel in all areas that will be in direct contact with new steel shall be prepared according to SSPC-SP15, Commercial Grade Power Tool Cleaning using vacuum-shrouded power tools equipped with HEPA filtration. The surface preparation shall remove all rust, mill scale, and existing paint from the contact surface. At the Contractors option, vacuum blast cleaning according to SSPC-SP6, Commercial Blast Cleaning may be substituted for SSPC-SP15 at no additional cost to the Department. The surface profile for primary connection surfaces shall be 1.5 to 3.5 mils (38 to 90 microns).

- b) **Secondary Connections.** Secondary connections shall be defined as all surface areas of existing members that will be in contact with new steel except as previously defined as primary connections.

These surfaces of existing steel in all areas that will be in direct contact with new steel shall be prepared according to SSPC-SP3, Power Tool Cleaning using vacuum-shrouded power tools equipped with HEPA filtration. The surface preparation shall remove all loose rust, loose mill scale, and loose, checked, alligatored and peeling paint from the contact surface. At the Contractors option, vacuum blast cleaning according to SSPC-SP6, Commercial Blast Cleaning or SSPC-SP15, Commercial Grade Power Tool Cleaning may be substituted for SSPC-SP3 at no additional cost to the Department. The surface profile for abrasive blast cleaning and Commercial Grade Power Tool Cleaning shall be 1.5 to 3.5 mils (38 to 90 microns).

Painting. The manufacturer's written instructions shall be followed for paint storage, mixing, thinning, application, ambient conditions, and drying times between coats. The surface shall be free of dirt, dust, and debris prior to the application of any coat. The coatings shall be applied as a continuous film of uniform thickness free of defects including, but not limited to, runs, sags, overspray, dryspray, pinholes, voids, skips, misses, and shadow-through. Defects such as runs and sags shall be brushed out immediately during application.

The Engineer will approve surface preparation prior to priming.

- a) For Primary connections the surface of the prepared steel cleaned to bare metal shall be primed with an organic zinc rich primer between 3.5 and 5.0 mils (90 and 125 microns) dry film thickness.
- b) For Secondary Connections the surface of the prepared steel cleaned to bare metal shall be painted with one coat of epoxy mastic between 5 and 7 mils (125 microns to 180 microns) in thickness. Areas not cleaned to bare metal need not be painted.

The primer shall cure according to the manufacturers instructions prior to connecting new structural steel to the existing structure.

The surrounding coating at each prepared location shall be feathered for a minimum distance of 1 1/2 in. (40 mm) to achieve a smooth transition between the prepared areas and the existing coating.

Collection, Temporary Storage, Transportation and Disposal of Waste. The Contractor and the Department are considered to be co-generators of the waste.

The Contractor is responsible for all aspects of waste collection, testing and identification, handling, storage, transportation, and disposal according to these specifications and all applicable Federal, State, and Local regulations. The Contractor shall provide for Engineer review and acceptance a Waste Management Plan that addresses all aspects of waste handling, storage, and testing, and provides the names, addresses, and a contact person for the proposed licensed waste haulers and disposal facilities. The Department will not perform any functions relating to the waste other than provide EPA identification numbers, provide the Contractor with the emergency response information, the emergency response telephone number required to be provided on the manifest, and to sign the waste manifest. The Engineer will obtain the identification numbers from the state and federal environmental protection agencies for the bridge(s) to be painted and furnish those to the Contractor.

All surface preparation/paint residues shall be collected daily and deposited in all-weather containers supplied by the Contractor as temporary storage. The storage area shall be secure to prevent unauthorized entry or tampering with the containers. Acceptable measures include storage within a fully enclosed (e.g., fenced in) and locked area, within a temporary building, or implementing other reasonable means to reduce the possibility of vandalism or exposure of the waste to the public or the environment (e.g., securing the lids or covers of waste containers and roll-off boxes). Waste shall not be stored outside of the containers. Waste shall be collected and transferred to bulk containers taking extra precautions as necessary to prevent the suspension of residues in air or contamination of surrounding surfaces. Precautions may include the transfer of the material within a tarpaulin enclosure. Transfer into roll-off boxes shall be planned to minimize the need for workers to enter the roll-off box.

No residues shall remain on uncontained surfaces overnight. Waste materials shall not be removed through floor drains or by throwing them over the side of the bridge. Flammable materials shall not be stored around or under any bridge structures.

The all-weather containers shall meet the requirements for the transportation of hazardous materials and as approved by the Department. Acceptable containers include covered roll-off boxes and 55-gallon drums (17H). The Contractor shall insure that no breaks and no deterioration of these containers occurs and shall maintain a written log of weekly inspections of the condition of the containers. A copy of the log shall be furnished to the Engineer upon request. The containers shall be kept closed and sealed from moisture except during the addition of waste. Each container shall be permanently identified with the date that waste was placed into the container, contract number, hazardous waste name and ID number, and other information required by the IEPA.

The Contractor shall have each waste stream sampled for each project and tested by TCLP and according to EPA and disposal company requirements. The Engineer shall be notified in advance when the samples will be collected. The samples shall be collected and shipped for testing within the first week of the project, with the results due back to the Engineer within 10 days.

The costs of testing shall be considered included in this work. Copies of the test results shall be provided to the Engineer prior to shipping the waste.

The existing paint removed, together with the surface preparation media (e.g. abrasive) shall be handled as a hazardous waste, regardless of the TCLP results. The waste shall be transported by a licensed hazardous waste transporter, treated by an IEPA permitted treatment facility to a non-hazardous special waste and disposed of at an IEPA permitted disposal facility in Illinois.

The treatment/disposal facilities shall be approved by the Engineer, and shall hold an IEPA permit for waste disposal and waste stream authorization for this cleaning residue. The IEPA permit and waste stream authorization must be obtained prior to beginning cleaning, except that if necessary, limited paint removal will be permitted in order to obtain samples of the waste for the disposal facilities. The waste shall be shipped to the facility within 90 days of the first accumulation of the waste in the containers. When permitted by the Engineer, waste from multiple bridges in the same contract may be transported by the Contractor to a central waste storage location(s) approved by the Engineer in order to consolidate the material for pick up, and to minimize the storage of waste containers at multiple remote sites after demobilization. Arrangements for the final waste pickup shall be made with the waste hauler by the time blast cleaning operations are completed or as required to meet the 90 day limit stated above.

The Contractor shall submit a waste accumulation inventory table to the Engineer no later than the 5th day of the month. The table shall show the number and size of waste containers filled each day in the preceding month and the amount of waste shipped that month, including the dates of shipments.

The Contractor shall prepare a manifest supplied by the IEPA for off-site treatment and disposal before transporting the hazardous waste off-site. The Contractor shall prepare a land ban notification for the waste to be furnished to the disposal facility. The Contractor shall obtain the handwritten signature of the initial transporter and date of the acceptance of the manifest. The Contractor shall send one copy of the manifest to the IEPA within two working days of transporting the waste off-site. The Contractor shall furnish the generator copy of the manifest and a copy of the land ban notification to the Engineer. The Contractor shall give the transporter the remaining copies of the manifest.

All other project waste shall be removed from the site according to Federal, State and Local regulations, with all waste removed from the site prior to final Contractor demobilization.

The Contractor shall make arrangements to have other hazardous waste, which he/she generates, such as used paint solvent, transported to the Contractor's facility at the end of each day that this waste is generated. These hazardous wastes shall be manifested using the Contractor's own generator number to a treatment or disposal facility from the Contractor's facility. The Contractor shall not combine solvents or other wastes with cleaning residue wastes. All waste streams shall be stored in separate containers.

The Contractor is responsible for the payment of any fines and undertaking any clean up activities mandated by State or federal environmental agencies for improper waste handling, storage, transportation, or disposal.

Contractor personnel shall be trained in the proper handling of hazardous waste, and the necessary notification and clean up requirements in the event of a spill. The Contractor shall maintain a copy of the personnel training records at each bridge site.

It is understood and agreed that the cost of all work outlined above, unless otherwise specified, has been included in the bid, and no extra compensation will be allowed.

Basis of Payment: This work will be considered included in the cost of "Furnishing and Erecting Structural Steel", "Erecting Structural Steel", or "Structural Steel Repair", as applicable, according to the Standard Specifications, unless otherwise specified on the plans.

CLEANING AND PAINTING NEW METAL STRUCTURES

Effective Date: September 13, 1994

Revised Date: January 22, 2010

Description. The material and construction requirements that apply to cleaning and painting new structural steel shall be according to the applicable portion of Sections 506 of the Standard Specifications except as modified herein. The three coat paint system shall be the system as specified on the plans and as defined herein. Unless stated otherwise, requirements imposed on the "Contractor" in this specification apply to both the shop painting contractor and the field painting contractor.

Materials. All materials to be used on an individual structure shall be produced by the same manufacturer. The Bureau of Materials and Physical Research has established a list of all products that have met preliminary requirements. Each batch of material must be tested and approved by that bureau before use.

The paint materials shall meet the requirements of the following articles of the Standard Specification:

<u>Item</u>	<u>Article</u>
(a) Inorganic Zinc-Rich Primer	1008.02
(b) Waterborne Acrylic	1008.04
(c) Aluminum Epoxy Mastic	1008.03
(d) Organic Zinc-Rich Primer (Note 1)	
(e) Epoxy Intermediate (Note 1)	
(f) Aliphatic Urethane (Note 1)	

Note 1: These material requirements shall be according to the Special Provision for the Organic Zinc-Rich Paint System.

Submittals. At least 30 days prior to beginning shop or field painting respectively, the Contractor shall submit for the Engineer's review and acceptance, the following applicable plans, certifications and information for completing the field work. Painting work shall not proceed until the submittals are accepted by the Engineer. Qualifications, certifications and QC plans for shop and field cleaning and painting shall be available for review by the QA Inspector.

- a) Contractor Shop Qualifications. Except for miscellaneous steel items such as bearings, side retainers, expansion joint devices, and other items allowed by the Engineer, or unless stated otherwise in the contract, the shop painting Contractors shall be certified to perform the work as follows: the shop painting Contractor shall possess AISC Sophisticated Paint Endorsement or SSPC-QP3 certification. Evidence of current qualifications shall be provided.
- b) Contractor Field Qualifications. Unless indicated otherwise on the contract plans, the field painting contractor shall possess current SSPC QP1 certification. Evidence of current qualifications shall be provided. The Contractor shall maintain certified status throughout the duration of the painting work under the contract. The Department reserves the right to accept Contractors documented to be currently enrolled in the SSPC-QP7, Painting Contractor Introductory Program, in lieu of the QP certifications noted above.
- c) QC Personnel Qualifications. Personnel managing the shop and field Quality Control program(s) for this work shall possess a minimum classification as a National Association of Corrosion Engineers (NACE) Coating Inspector Level 2-Certified, or shall provide evidence of successful inspection of 3 projects of similar or greater complexity and scope that have been completed in the last 2 years. Copies of the certification and/or experience shall be provided, including names, addresses and telephone numbers of contact persons employed by the bridge owner.

The personnel performing the QC tests for this work shall be trained in coatings inspection and the use of the testing instruments. Documentation of training shall be provided. The QC personnel shall not perform hands on surface preparation or paint activities unless otherwise approved by the Engineer. Painters shall perform wet film thickness measurements, with QC personnel conducting random spot checks of the wet film. The Contractor shall not replace the QC personnel assigned to the project without advance notice to the Engineer, and acceptance of the replacement(s), by the Engineer.

- d) Quality Control (QC) Program. The shop and field QC Programs shall identify the following; the instrumentation that will be used, a schedule of required measurements and observations, procedures for correcting unacceptable work, and procedures for improving surface preparation and painting quality as a result of quality control findings. The shop program shall include a copy of the quality control form(s) that will be completed daily. The field program shall incorporate the IDOT Quality Control Daily Report form, as supplied by the Engineer.
- e) Field Cleaning and Painting Inspection Access Plan. The inspection access plan for use by Contractor QC personnel for ongoing inspections and by the Engineer during Quality Assurance (QA) observations.
- f) Surface Preparation/Painting Plan. The surface preparation/painting plan shall include the methods of surface preparation and type of equipment to be utilized for solvent cleaning, abrasive blast cleaning, washing, and power tool cleaning. The plan shall include the manufacturer's names of the materials that will be used, including Product Data Sheets and Material Safety Data Sheets (MSDS).

A letter or written instructions from the coating manufacturer shall be included, indicating the required drying time for each coat at the minimum, normal, and maximum application temperatures before the coating can be exposed to temperatures or moisture conditions that are outside of the published application parameters. Application shall be performed in accordance with the coating manufacturer's instructions.

Quality Control (QC) Inspections. The Contractor shall perform first line, in process QC inspections of each phase of the work. The submitted and accepted QC Program(s) shall be used to insure that the work accomplished complies with these specifications. The shop painting Contractor shall use their forms as supplied in their submittal. These shop reports shall be made available for review when requested by the Engineer. The field painting Contractor shall use the IDOT Quality Control Daily Report form supplied by the Engineer to record the results of quality control tests. These field reports shall be turned into the Engineer before work resumes the following day.

The Contractor shall supply all necessary equipment to perform the QC inspections. Equipment shall include the following at a minimum:

- Psychrometer or comparable equipment for the measurement of dew point and relative humidity, together with all necessary weather bureau tables or psychrometric charts.
- Surface temperature thermometer.
- Bresle Cell Kits or CHLOR*TEST kits for chloride determinations, or equivalent.(only required when erected steel is exposed through the winter prior to field painting.)
- Wet Film Thickness Gage.
- Blotter paper for compressed air cleanliness checks.
- Type 2 Magnetic Dry Film Thickness Gage per SSPC - PA2.
- Calibration standards for dry film thickness gage.
- Light meter for measuring light intensity during cleaning, painting, and inspection activities.
- All applicable ASTM and SSPC Standards used for the work.
- Commercially available putty knife of a minimum thickness of 40 mils (1 mm) and a width between 1 and 3 in. (25 and 75 mm). Note that the putty knife is only required in touch-up areas where the coating is being feathered and must be tested with a dull putty knife.

The instruments shall be calibrated by the Contractor's personnel according to the equipment manufacturer's recommendations and the Contractor's QC Program. All inspection equipment shall be made available to the Engineer for QA observations on an as needed basis.

Quality Assurance (QA) Observations. The Engineer may conduct QA observations of any or all phases of the shop or field work. The Engineer's observations in no way relieve the Contractor of the responsibility to provide all necessary daily QC inspections of his/her own and to comply with all requirements of this Specification.

Inspection Access and Lighting. The Contractor shall facilitate the Engineer's observations as required, including allowing ample time to view the work. The field Contractor shall furnish, erect and move scaffolding or other mechanical equipment to permit close observation of all surfaces to be cleaned and painted. This equipment shall be provided during all phases of the work. Examples of acceptable access structures include:

- Mechanical lifting equipment, such as, scissor trucks, hydraulic booms, etc.
- Platforms suspended from the structure comprised of trusses or other stiff supporting members and including rails and kick boards.
- Simple catenary supports are permitted only if independent life lines for attaching a fall arrest system according to Occupational Safety and Health Administration (OSHA) regulations are provided.

When the surface to be inspected is more than 6 ft. (1.8 m) above the ground or water surface, and fall protection is not provided (e.g. guardrails) the Contractor shall provide the Engineer with a safety harness and a lifeline according to OSHA regulations. The lifeline and attachment shall not direct the fall into oncoming traffic. The Contractor shall provide a method of attaching the lifeline to the structure independent of the inspection facility or any support of the platform. When the inspection facility is more than 2 1/2 ft. (800 mm) above the ground, the Contractor shall provide an approved means of access onto the platform.

The Contractor shall provide artificial lighting in areas where natural light is inadequate, as determined by the Engineer, to allow proper cleaning, inspection, and painting. Illumination for inspection shall be at least 30 foot candles (325 LUX). Illumination for cleaning and painting, including the working platforms, access, and entryways shall be at least 20 foot candles (215 LUX).

Construction Requirements for Field Painting. The Contractor shall be responsible for any damage caused to persons, vehicles, or property, except as indemnified by the Response Action Contractor Indemnification Act. Whenever the intended purposes of the protective devices are not being accomplished, as determined by the Engineer, work shall be immediately suspended until corrections are made. Painted surfaces damaged by any Contractor's operation shall be removed and repainted, as directed by the Engineer, at the Contractor's expense.

The Contractor shall comply with the provisions of the Illinois Environmental Protection Act. Paint drips, spills, and overspray are not permitted to escape into the air or onto any other surfaces or surrounding property not intended to be painted. Containment shall be used to control paint drips, spills, and overspray, and shall be dropped and all equipment secured when sustained wind speeds of 40 mph (64 kph) or greater occur, unless the containment design necessitates action at lower wind speeds. When the containment needs to be attached to the structure, it shall be attached by clamping or similar means. Welding or drilling into the structure shall be prohibited unless otherwise approved by the Engineer in writing. The Contractor shall evaluate project-specific conditions to determine the specific type and extent of containment needed to control the paint emissions and shall submit a plan for containing or controlling paint debris (droplets, spills, overspray, etc.) to the Engineer for approval prior to starting the work. Approval shall not relieve the Contractor of their ultimate responsibility for controlling paint debris from escaping the work zone.

Hold Point Notification for Field Painting. Specific inspection items throughout this specification are designated as Hold Points. Unless other arrangements are made at the project site, the Contractor shall provide the Engineer with a minimum 4-hour notification before a Hold Point inspection will be reached. If the 4-hour notification is provided and the Work is ready for inspection at that time, the Engineer will conduct the necessary observations. If the Work is not ready at the appointed time, unless other arrangements are made, an additional 4-hour notification is required.

Permission to proceed beyond a Hold Point without a QA inspection will be granted solely at the discretion of the Engineer, and only on a case by case basis. The Engineer has the right to reject any work that was performed without adequate provision for QA observations.

Field Surface Preparation (HOLD POINT). The following processes shall be used to prepare the shop-coated steel surfaces for field painting.

1. Low Pressure Water Cleaning and Solvent Cleaning. The Contractor shall notify the Engineer 24 hours in advance of beginning surface preparation operations.

Washing shall involve the use of potable water at a minimum of 1000 psi (7 MPa) and less than 5000 psi (34 MPa) according to "Low Pressure Water Cleaning" of SSPCSP12. Paint spray equipment shall not be used to perform the water cleaning. The cleaning shall be performed in such a manner as to remove dust, dirt, chalk, insect and animal nests, bird droppings, and other foreign matter prior to solvent cleaning.

If detergents or other additives are added to the water, the detergents/additives shall be included in the submittals and not used until accepted by the Engineer. When detergents or additives are used, the surface shall be rinsed with potable water before the detergent water dries.

After washing has been accepted by the Engineer, all traces of asphaltic cement, oil, grease, diesel fuel deposits, and other soluble contaminants which remain on the steel surfaces to be painted shall be removed according to SSPC – SP1 Solvent Cleaning, supplemented with scraping (e.g., to remove large deposits of asphaltic cement) as required. The solvent(s) used for cleaning shall be compatible with the primer. The Contractor shall identify the proposed solvent(s) in the submittals. If the primer is softened, wrinkled, or shows other signs of attack from the solvents, the Contractor shall immediately discontinue their use. The name and composition of replacement solvents, together with MSDS, shall be submitted for Engineer acceptance prior to use. If solvent cleaning/scraping is not successful in removing the foreign matter, the Contractor shall use other methods identified in SP1, such as steam cleaning as necessary.

2. Water Cleaning Between Coats. When foreign matter has accumulated on a newly applied coat, washing shall be performed prior to the application of subsequent coats.
3. Power Tool Cleaning of Shop-Coated Steel. Damaged and rusted areas shall be spot cleaned according Power Tool Cleaning SSPC-SP3 (Modified). The edges of the coating surrounding the spot repairs shall be feathered. A power tool cleaned surface shall be free of all loose rust, loose and peeling paint, and loose rust that is bleeding through and/or penetrating the coating. All locations of visible corrosion and rust bleed, and lifting or loose paint shall be prepared using the power tools.

Upon completion of the cleaning, rust, rust bleed, and surrounding paint are permitted to remain if they cannot be lifted using a dull putty knife.

Field Soluble Salt Remediation (HOLD POINT). If the erected steel is exposed to winter weather prior to field painting, the Contractor shall implement surface preparation procedures and processes that will remove chloride from the surfaces prior to field painting.

Surfaces that may be contaminated with chloride include, but are not limited to, expansion joints and all areas that are subject to roadway splash or run off such as fascia beams and stringers.

Methods of chloride removal may include, but are not limited to, steam cleaning or pressure washing with or without the addition of a chemical soluble salt remover as approved by the coating manufacturer, and scrubbing before or after initial paint removal. The water does not need to be collected. The Contractor shall provide the proposed procedures for chloride remediation in the Surface Preparation/Painting Plan.

Upon completion of the chloride remediation steps, the Contractor shall use cell methods of field chloride extraction and test procedures (e.g., silver dichromate) accepted by the Engineer, to test representative surfaces for the presence of remaining chlorides. Remaining chloride levels shall be no greater than 7 μ g/sq cm as read directly from the surface without any multiplier applied to the results. The testing must be performed, and the results must be acceptable.

Surface and Weather Conditions (HOLD POINT). Surfaces to be painted after cleaning shall remain free of moisture and other contaminants. The Contractor shall control his/her operations to insure that dust, dirt, or moisture does not come in contact with surfaces cleaned or painted that day.

Prepared surfaces, shall meet the requirements of the respective degrees of cleaning immediately prior to painting, and shall be painted before rusting appears on the surface. If rust appears or bare steel remains unpainted for more than 12 hours, the affected area shall be prepared again at the expense of the Contractor.

The surface temperature shall be at least 5°F (3°C) above the dew point during final surface preparation operations. The paint manufacturers' published literature shall be followed for specific temperature, dew point, and humidity restrictions during the application of each coat, and for the minimum and maximum time between coats.

The Contractor shall monitor temperature, dew point, and humidity every 4 hours during surface preparation and coating application in the specific areas where the work is being performed. The frequency of monitoring shall increase if weather conditions are changing. The Engineer has the right to reject any work that was performed under unfavorable weather conditions. Rejected work shall be removed, and repainted at the Contractor's expense.

Seasonal Restrictions on Field Cleaning and Painting. Field cleaning and painting work shall be accomplished between April 15 and October 31 unless authorized otherwise by the Engineer in writing.

Inorganic Zinc-rich/ Waterborne Acrylic Paint system. This system shall be for shop and field application of the coating system. Shop application of the intermediate and top coats will not be allowed.

In the shop, all structural steel designated to be painted shall be given one coat of inorganic zinc rich primer. In the field, before the application of the intermediate coat, the prime coat and any newly installed fasteners shall be spot solvent cleaned per SSPC-SP 1 and all surfaces pressure washed as specified above. All damaged shop primed areas shall be spot cleaned per SSPC-SP3 Modified,

All damaged areas and all installed fasteners shall be fully primed with aluminum epoxy mastic. The structural steel shall then receive one full intermediate coat and one full topcoat of waterborne acrylic paint.

- a) Coating Dry Film Thickness (dft), measured according to SSPC-PA2:
 - a. Zinc Primer: 3 mils (75 microns) min., 6 mils (150 microns) max.
 - b. Epoxy Mastic (spot coat): 5 mils (125 microns) min., 7 mils (180 microns) max.
 - c. Intermediate Coat: 2 mils (50 microns) min., 4 mils (100 microns) max.
 - d. Topcoat: 2 mils (50 microns) min., 4 mils (100 microns) max.
- b) The total dry film thickness, excluding the spot areas touched up with epoxy mastic, shall be between 7 and 14 mils (180 and 355 microns).
- c) The pressure washing requirement above may be waived if the QC and QA Inspectors verify the primed surfaces have not been contaminated.
- d) Damage to the completed paint system shall be spot cleaned using SSPC-SP3 (Modified). The cleaned areas shall be spot painted with a penetrating sealer as recommended by the manufacturer, which shall overlap onto the existing topcoat. Then the aluminum epoxy mastic shall be spot applied not to go beyond the area painted with the sealer. The acrylic intermediate and topcoat shall be spot applied to the mastic with at least a 6 inch (150 mm) overlap onto the existing topcoat.

Organic Zinc-Rich/ Epoxy/ Urethane Paint System. This system shall be for full shop application of the coating system, or when specified on the plans, for the application of two coats in the shop with the finish coat applied in the field. All contact surfaces shall be masked off prior to shop-application of the intermediate and top coats.

In addition to the requirements of Section 3.2.9 of the AASHTO/AWS D1.5/D1.5:2002 Bridge Welding Code (breaking thermal cut corners of stress carrying members), rolled and thermal cut corners to be painted with organic zinc primer shall be broken if they are sharper than a 1/16 in. (1.5 mm) radius. Corners shall be broken by a single pass of a grinder or other suitable device at a 45 degree angle to each adjoining surface prior to final blast cleaning, so the resulting corner approximates a 1/16 in. (1.5 mm) or larger radius after blasting. Surface anomalies (burrs, fins, deformations) shall also be treated to meet this criteria before priming.

In the shop, all structural steel designated to be painted shall be given one coat of organic zinc rich primer, one coat of epoxy intermediate, and unless stated otherwise in the plans, one coat of urethane finish. Before the application of the field coats, the shop coats and any newly installed fasteners shall be spot solvent cleaned per SSPC-SP 1 and all surfaces pressure washed as specified above to remove dirt, oil, lubricants, oxidation products, and foreign substances. All damaged shop coated areas shall then be spot cleaned per SSPC-SP3 (Modified). The surrounding coating at each repair location shall be feathered for a minimum distance of 1 1/2 in. (40 mm) to achieve a smooth transition between the prepared areas and the existing coating. The existing coating in the feathered area shall be roughened to insure proper adhesion of the repair coats.

All damaged areas and all newly installed fasteners shall be fully primed with epoxy mastic.

One intermediate coat of epoxy shall be applied over the epoxy mastic and on exposed shop primer. One topcoat of aliphatic urethane shall be applied to all areas where the intermediate coat is visible, whether the intermediate coat was applied in the shop or in the field. The field applied coats shall only overlap onto the existing finish coat where sanding has been performed.

When the plans require the urethane coat to be applied in the field, the maximum recoat time for the intermediate coat shall be observed. If the recoat time for the intermediate coat is exceeded, the Contractor shall remove the shop-applied system, or submit for approval by the Engineer, written recommendations from the coating manufacturer for the procedures necessary to extend that recoat window or otherwise prepare the intermediate coat to receive the finish.

- (a) Coating Dry Film Thickness (dft), measured according to SSPC-PA2:
 - Organic Zinc-Rich Primer: 3 mils (75 microns) min., 5 mils (125 microns) max.
 - Aluminum Epoxy Mastic (spot coat): 5 mils (125 microns) min., 7 mils (180 microns) max.
 - Epoxy Intermediate Coat: 3 mils (75 microns) min., 6 mils (150 microns) max.
 - Aliphatic Urethane Top Coat: 2.5 mils (65 microns) min., 4 mils (100 microns) max.
- (b) The total dry film thickness, excluding the spot areas touched up with epoxy mastic, shall be between 8.5 and 15 mils (215 and 375 microns).
- (c) All faying surfaces of field connections shall be masked off after priming and shall not receive the intermediate or top coats in the shop. The intermediate and top coats for field connections shall be applied, in the field, after erection of the structural steel is completed.

Special Instructions.

Painting Date/System Code. At the completion of the work, the Contractor shall stencil in contrasting color paint the date of painting the bridge, the painting Contractors name, and the paint type code from the Structure Information and Procedure Manual for the system used. The letters shall be capitals, not less than 2 in. (50 mm) and not more than 3 in. (75 mm) in height. When all coats are applied in the shop the shop Contractor shall do the stenciling. When 1 or more coats are applied in the field, the field contractor shall do the stenciling.

The stencil shall contain the following wording "PAINTED BY (insert the name of the painting Contractor)" and shall show the month and year in which the painting was completed, followed by "CODE S" for the Inorganic Zinc/ Acrylic System, "CODE X" for the Organic Zinc/ Epoxy/ Urethane System (field applied finish coats), "CODE AB" for the Organic Zinc/ Epoxy/ Urethane System (shop applied), all stenciled on successive lines. This information shall be stenciled on the cover plate of a truss end post near the top of the railing, or on the outside face of an outside stringer near both ends of the bridge facing traffic, or at some equally visible surface designated by the Engineer.

Method of Measurement. Shop cleaning and painting new structures will not be measured for payment. Field cleaning and painting will not be measured for payment except when performed under a contract that contains a separate pay item for this work.

Basis of Payment. This work will be paid for according to Article 506.07.

CLEANING AND PAINTING EXISTING STEEL STRUCTURES

Effective: October 2, 2001

Revised: February 1, 2010

Description. This work shall consist of the preparation of all designated metal surfaces by the method(s) specified on the plans. This work also includes the painting of those designated surfaces with the paint system(s) specified on the plans. The Contractor shall furnish all materials, equipment, labor, and other essentials necessary to accomplish this work and all other work described herein and as directed by the Engineer.

Materials. All materials to be used on an individual structure shall be produced by the same manufacturer.

The Bureau of Materials and Physical Research has established a list of all products that have met preliminary requirements. Each batch of material, except for the penetrating sealer, must be tested and approved before use. The specified colors shall be produced in the coating manufacturer's facility. Tinting of the coating after it leaves the manufacturer's facility is not allowed.

The paint materials shall meet the following requirements of the Standard Specification and as noted below:

<u>Item</u>	<u>Article</u>
(a) Waterborne Acrylic	1008.04
(b) Aluminum Epoxy Mastic	1008.03
(c) Organic Zinc Rich Primer (Note 1)	
(d) Epoxy/ Aliphatic Urethane (Note 1)	
(e) Penetrating Sealer (Note 2)	
(f) Moisture Cured Zinc Rich Urethane Primer (Note 3)	
(g) Moisture Cured Aromatic/Aliphatic Urethane (Note 3)	
(h) Moisture Cured Penetrating Sealer (Note 4)	

Note 1: These material requirements shall be according to the Special Provision for the Organic Zinc-Rich Paint System.

Note 2: The Epoxy Penetrating Sealer shall be a cross-linked multi component sealer. The sealer shall have the following properties:

- (a) The volume solids shall be 98 percent (plus or minus 2 percent).
- (b) Shall be clear or slightly tinted color.

Note 3: These material requirements shall be according to the Special Provision for the Moisture Cured Urethane Paint System.

Note 4: The Moisture Cured Penetrating Sealer manufacturer's certification will be required.

Submittals. The Contractor shall submit for Engineer review and acceptance, the following plans and information for completing the work. The submittals shall be provided within 30 days of execution of the contract unless given written permission by the Engineer to submit them at a later date. Work cannot proceed until the submittals are accepted by the Engineer. Details for each of the plans are presented within the body of this specification.

- a) Contractor/Personnel Qualifications. Evidence of Contractor qualifications and the names and qualifications/experience/training of the personnel managing and implementing the Quality Control program and conducting the quality control tests.
- b) Quality Control (QC) Program. The QC Program shall identify the following; the instrumentation that will be used, a schedule of required measurements and observations, procedures for correcting unacceptable work, and procedures for improving surface preparation and painting quality as a result of quality control findings. The program shall incorporate at a minimum, the IDOT Quality Control Daily Report form as supplied by the Engineer.
- c) Inspection Access Plan. The inspection access plan for use by Contractor QC personnel for ongoing inspections and by the Engineer during Quality Assurance (QA) observations.
- d) Surface Preparation/Painting Plan. The surface preparation/painting plan shall include the methods of surface preparation and type of equipment to be utilized for washing, hand/power tool cleaning, removal of rust, mill scale, paint or foreign matter, abrasive blast or water jetting, and remediation of chloride. If detergents, additives, or inhibitors are incorporated into the water, the Contractor shall include the names of the materials and Material Safety Data Sheets (MSDS). The Contractor shall identify the solvents proposed for solvent cleaning together with MSDS.

The plan shall also include the methods of coating application and equipment to be utilized.

If the Contractor proposes to heat or dehumidify the containment, the methods and equipment proposed for use shall be included in the Plan for the Engineer's consideration.

- e) Paint Manufacturer Certifications and Letters. When a sealer is used, the Contractor shall provide the manufacturer's certification of compliance with IDOT testing requirements listed under "Materials" above. A certification regarding the compatibility of the sealer with the specified paint system shall also be included.

When rust inhibitors are used, the Contractor shall provide a letter from the coating manufacturer indicating that the inhibitor is compatible with, and will not adversely affect the performance of the coating system.

If the use of a chemical soluble salt remover is proposed by the Contractor, provide a letter from the coating manufacturer indicating that the material will not adversely effect the performance of the coating system.

The paint manufacturer's application and thinning instructions, MSDS and product data sheets shall be provided, with specific attention drawn to storage temperatures, and the temperatures of the material, surface and ambient air at the time of application.

A letter or written instructions from the coating manufacturer shall be provided indicating the length of time that each coat must be protected from cold or inclement weather (e.g., exposure to rain) during its drying period.

- f) Abrasives. Abrasives to be used for abrasive blast cleaning, including MSDS. For expendable abrasives, the Contractor shall provide certification from the abrasive supplier that the abrasive meets the requirements of SSPC-AB1. For steel grit abrasives, the certification shall indicate that the abrasive meets the requirements of SSPC-AB3.
- g) Protective Coverings. Plan for containing or controlling paint debris (droplets, spills, overspray, etc.). Any tarpaulins or protective coverings proposed for use shall be fire retardant. For submittal requirements involving the containment used to remove lead paint, the Contractor shall refer to Special Provision for Containment and Disposal of Lead Paint Cleaning Residues.
- h) Progress Schedule. Progress schedule shall be submitted per Article 108.02 and shall identify all major work items (e.g., installation of rigging/containment, surface preparation, and coating application).

When the Engineer accepts the submittals, the Contractor will receive written notification. The Contractor shall not begin any paint removal work until the Engineer has accepted the submittals. The Contractor shall not construe Engineer acceptance of the submittals to imply approval of any particular method or sequence for conducting the work, or for addressing health and safety concerns. Acceptance of the programs does not relieve the Contractor from the responsibility to conduct the work according to the requirements of Federal, State, or Local regulations and this specification, or to adequately protect the health and safety of all workers involved in the project and any members of the public who may be affected by the project. The Contractor remains solely responsible for the adequacy and completeness of the programs and work practices, and adherence to them.

Contractor Qualifications. Unless indicated otherwise on the plans, for non lead abatement projects, the painting Contractor shall possess current SSPC-QP1 certification. For lead abatement projects the Contractor shall also possess current SSPC-QP2 certification. The Contractor shall maintain certified status throughout the duration of the painting work under the contract. The Department reserves the right to accept Contractors documented to be currently enrolled in the SSPC-QP7, Painting Contractor Introductory Program, Category 2, in lieu of the QP certifications noted above.

Quality Control (QC) Inspections. The Contractor shall perform first line, in process QC inspections. The Contractor shall implement the submitted and accepted QC Program to insure that the work accomplished complies with these specifications. The designated Quality Control inspector shall be onsite full time during any operations that affect the quality of the coating system (e.g., surface preparation and chloride remediation, coating mixing and application, and evaluations between coats and upon project completion). The Contractor shall use the IDOT Quality Control Daily Report form supplied by the Engineer to record the results of quality control tests.

The completed reports shall be turned into the Engineer before work resumes the following day.

Contractor QC inspections shall include, but not be limited to the following:

- Suitability of protective coverings and the means employed to control project debris and paint spills, overspray, etc.
- Ambient conditions
- Surface preparation (solvent cleaning, pressure washing including chalk tests, hand/power tool or abrasive blast cleaning, etc.)
- Chloride remediation
- Coating application (specified materials, mixing, thinning, and wet/dry film thickness)
- Recoat times and cleanliness between coats
- Coating continuity and coverage (freedom from runs, sags, overspray, dryspray, pinholes, shadow-through, skips, misses, etc.)

The personnel managing the Contractor's QC Program shall possess a minimum classification as a National Association of Corrosion Engineers (NACE) Coating Inspector Level 2 - Certified, or shall provide evidence of successful inspection of 3 projects of similar or greater complexity and scope that have been completed in the last 2 years. Copies of the certification and/or experience shall be provided. References for experience shall be provided and shall include the name, address, and telephone number of a contact person employed by the bridge owner.

The personnel performing the QC tests shall be trained in coatings inspection and the use of the testing instruments. Documentation of training shall be provided. The QC personnel shall not perform hands on surface preparation or painting activities. Painters shall perform wet film thickness measurements, with QC personnel conducting random spot checks of the wet film. The Contractor shall not replace the QC personnel assigned to the project without advance notice to the Engineer, and acceptance of the replacement(s), by the Engineer.

The Contractor shall supply all necessary equipment to perform the QC inspections. Equipment shall include the following at a minimum:

- Psychrometer or comparable equipment for the measurement of dew point and relative humidity, together with all necessary weather bureau tables or psychrometric charts.
- Surface temperature thermometer
- SSPC Visual Standards VIS 1, Guide and Reference Photographs for Steel Surfaces Prepared by Dry Abrasive Blast Cleaning; SSPC-VIS 3, Visual Standard for Power and Hand-Tool Cleaned Steel; SSPC-VIS 4, Guide and Reference Photographs for Steel Prepared by Water Jetting, and/or SSPC-VIS 5, Guide and Reference Photographs for Steel Prepared by Wet Abrasive Blast Cleaning, as applicable.
- Commercially available putty knife of a minimum thickness of 40 mils (1mm) and a width between 1 and 3 in. (25 and 75 mm). Note that the putty knife is only required for projects in which the existing coating is being feathered and must be tested with a dull putty knife.
- Testex Press-O-Film Replica Tape and Spring Micrometer
- Bresle Cell Kits or CHLOR*TEST kits for chloride determinations, or equivalent
- Wet Film Thickness Gage
- Blotter paper for compressed air cleanliness checks

- Type 2 Electronic Dry Film Thickness Gage per SSPC - PA2, Measurement of Dry Coating Thickness with magnetic Gages
- Calibration standards for dry film thickness gage
- Light meter for measuring light intensity during paint removal, painting, and inspection activities
- All applicable ASTM and SSPC Standards used for the work (reference list attached)

The instruments shall be calibrated by the Contractor's personnel according to the equipment manufacturer's recommendations and the Contractor's QC Program. All inspection equipment shall be made available to the Engineer for QA observations on an as needed basis.

Hold Point Notification. Specific inspection items throughout this specification are designated as Hold Points. Unless other arrangements are made at the project site, the Contractor shall provide the Engineer with a minimum 4-hour notification before a Hold Point inspection will be reached. If the 4-hour notification is provided and the Work is ready for inspection at that time, the Engineer will conduct the necessary observations. If the Work is not ready at the appointed time, unless other arrangements are made, an additional 4-hour notification is required. Permission to proceed beyond a Hold Point without a QA inspection will be granted solely at the discretion of the Engineer, and only on a case by case basis.

Quality Assurance (QA) Observations. The Engineer will conduct QA observations of any or all phases of the work. The presence or activity of Engineer observations in no way relieves the Contractor of the responsibility to provide all necessary daily QC inspections of his/her own and to comply with all requirements of this Specification.

The Engineer has the right to reject any work that was performed without adequate provision for QA observations.

Inspection Access and Lighting. The Contractor shall facilitate the Engineer's observations as required, including allowing ample time to view the work. The Contractor shall furnish, erect and move scaffolding or other mechanical equipment to permit close observation of all surfaces to be cleaned and painted. This equipment shall be provided during all phases of the work. Examples of acceptable access structures include:

- Mechanical lifting equipment, such as, scissor trucks, hydraulic booms, etc.
- Platforms suspended from the structure comprised of trusses or other stiff supporting members and including rails and kick boards.
- Simple catenary supports are permitted only if independent life lines for attaching a fall arrest system according to Occupational Safety and Health Administration (OSHA) regulations are provided.

When the surface to be inspected is more than 6 ft. (1.8 m) above the ground or water surface, and fall protection is not provided (e.g., guardrails are not provided), the Contractor shall provide the Engineer with a safety harness and a lifeline according to OSHA regulations. The lifeline and attachment shall not direct the fall into oncoming traffic. The Contractor shall provide a method of attaching the lifeline to the structure independent of the inspection facility or any support of the platform. When the inspection facility (e.g., platform) is more than 2 1/2 ft. (800 mm) above the ground, the Contractor shall provide an approved means of access onto the platform.

The Contractor shall provide artificial lighting in areas where natural light is inadequate, as determined by the Engineer, to allow proper cleaning, inspection, and painting. Illumination for inspection shall be at least 30 foot candles (325 LUX). Illumination for cleaning and painting, including the working platforms, access and entryways shall be at least 20 foot candles (215 LUX).

Surface Preparation and Painting Equipment. All cleaning and painting equipment shall include gages capable of accurately measuring fluid and air pressures and shall have valves capable of regulating the flow of air, water or paint as recommended by the equipment manufacturer. The equipment shall be maintained in proper working order.

Diesel or gasoline powered equipment shall be positioned or vented in a manner to prevent deposition of combustion contaminants on any part of the structure.

Hand tools, power tools, pressure washing, water jetting, abrasive blast cleaning equipment, brushes, rollers, and spray equipment shall be of suitable size and capacity to perform the work required by this specification. All power tools shall be equipped with vacuums and High Efficiency Particulate Air (HEPA) filtration. Appropriate filters, traps and dryers shall be provided for the compressed air used for abrasive blast cleaning and conventional spray application. Paint pots shall be equipped with air operated continuous mixing devices unless prohibited by the coating manufacturer.

Test Sections. Prior to surface preparation, the Contractor shall prepare a test section(s) on each structure to be painted in a location(s) which the Engineer considers to be representative of the existing surface condition and steel type for the structure as a whole. More than one test section may be needed to represent the various design configurations of the structure. The purpose of the test section(s) is to demonstrate the use of the tools and degree of cleaning required (cleanliness and profile) for each method of surface preparation that will be used on the project. Each test section shall be approximately 10 sq. ft. (0.93 sq m). The test section(s) shall be prepared using the same equipment, materials and procedures as the production operations. The Contractor shall prepare the test section(s) to the specified level of cleaning according to the appropriate SSPC visual standards, modified as necessary to comply with the requirements of this specification. The written requirements of the specification prevail in the event of a conflict with the SSPC visual standards. Only after the test section(s) have been approved shall the Contractor proceed with surface preparation operations. Additional compensation will not be allowed the Contractor for preparation of the test section(s).

For the production cleaning operations, the specifications and written definitions, the test section(s), and the SSPC visual standards shall be used in that order for determining compliance with the contractual requirements.

Protective Coverings and Damage. All portions of the structure that could be damaged by the surface preparation and painting operations (e.g., utilities), including any sound paint that is allowed to remain according to the contract documents, shall be protected by covering or shielding. Tarpaulins drop cloths, or other approved materials shall be employed. The Contractor shall comply with the provisions of the Illinois Environmental Protection Act. Paint drips, spills, and overspray are not permitted to escape into the air or onto any other surfaces or surrounding property not intended to be painted.

Containment shall be used to control paint drips, spills, and overspray, and shall be dropped and all equipment secured when sustained wind speeds of 40 mph (64 kph) or greater occur, unless the containment design necessitates action at lower wind speeds. The contractor shall evaluate project-specific conditions to determine the specific type and extent of containment needed to control the paint emissions and shall submit a plan for containing or controlling paint debris (droplets, spills, overspray, etc.) to the Engineer for approval prior to starting the work. Approval shall not relieve the Contractor of their ultimate responsibility for controlling paint debris from escaping the work zone.

When the protective coverings need to be attached to the structure, they shall be attached by bolting, clamping, or similar means. Welding or drilling into the structure is prohibited unless approved by the Engineer in writing. When removing coatings containing lead the containment and disposal of the residues shall be as specified in the Special Provision for Containment and Disposal of Lead Paint Cleaning Residues contained elsewhere in this Contract. When removing coatings not containing lead the containment and disposal of the residues shall be as specified in the Special Provision for Containment and Disposal of Non-Lead Paint Cleaning Residues contained elsewhere in this Contract.

The Contractor shall be responsible for any damage caused to persons, vehicles, or property, except as indemnified by the Response Action Contractor Indemnification Act. Whenever the intended purposes of the controls or protective devices used by the Contractor are not being accomplished, as determined by the Engineer, work shall be immediately suspended until corrections are made. Damage to vehicles or property shall be repaired by the Contractor at the Contractor's expense. Painted surfaces damaged by any Contractor's operation shall be repaired, removed and/or repainted, as directed by the Engineer, at the Contractor's expense.

Weather Conditions. Surfaces to be painted after cleaning shall remain free of moisture and other contaminants. The Contractor shall control his/her operations to insure that dust, dirt, or moisture do not come in contact with surfaces cleaned or painted that day.

- a) The surface temperature shall be at least 5°F (3°C) above the dew point during final surface preparation operations. The manufacturers' published literature shall be followed for specific temperature, dew point, and humidity restrictions during the application of each coat.
- b) If the Contractor proposes to control the weather conditions inside containment, proposed methods and equipment for heating and/or dehumidification shall be included in the work plans for the Engineer's consideration. Any heating/dehumidification proposals accepted by the Engineer shall be implemented at no additional cost to the department.
- c) Cleaning and painting shall be done between April 15 and October 31 unless authorized otherwise by the Engineer in writing.

The Contractor shall monitor temperature, dew point, and relative humidity every 4 hours during surface preparation and coating application in the specific areas where the work is being performed. The frequency of monitoring shall increase if weather conditions are changing. If the weather conditions after application and during drying are forecast to be outside the acceptable limits established by the coating manufacturer, coating application shall not proceed.

If the weather conditions are forecast to be borderline relative to the limits established by the manufacturer, monitoring shall continue at a minimum of 4-hour intervals throughout the drying period. The Engineer has the right to reject any work that was performed, or drying that took place, under unfavorable weather conditions. Rejected work shall be removed, recleaned, and repainted at the Contractor's expense.

Compressed Air Cleanliness. Prior to using compressed air for abrasive blast cleaning, blowing down the surfaces, and painting with conventional spray, the Contractor shall verify that the compressed air is free of moisture and oil contamination according to the requirements of ASTM D 4285. The tests shall be conducted at least one time each shift for each compressor system in operation. If air contamination is evident, the Contractor shall change filters, clean traps, add moisture separators or filters, or make other adjustments as necessary to achieve clean, dry air. The Contractor shall also examine the work performed since the last acceptable test for evidence of defects or contamination caused by the compressed air. Effected work shall be repaired at the Contractor's expense.

Low Pressure Water Cleaning and Solvent Cleaning (HOLD POINT). The Contractor shall notify the Engineer 24 hours in advance of beginning surface preparation operations.

- a) Water Cleaning of Lead Containing Coatings Prior to Overcoating. Prior to initiating any mechanical cleaning such as hand/power tool cleaning on surfaces that are painted with lead, all surfaces to be prepared and painted, and the tops of pier and abutment caps shall be washed. Washing is not required if the surfaces will be prepared by water jetting.

Washing shall involve the use of potable water at a minimum of 1000 psi (7 MPa) and less than 5000 psi (34 MPa) according to "Low Pressure Water Cleaning" of SSPC-SP12. Paint spray equipment shall not be used to perform the water cleaning. The cleaning shall be performed in such a manner as to remove dust, dirt, chalk, insect and animal nests, bird droppings, loose paint and other foreign matter prior to solvent cleaning. The water, debris, and any loose paint removed by water cleaning shall be collected for proper disposal. The washing shall be completed no more than 2 weeks prior to surface preparation.

If detergents or other additives are added to the water, the detergents/additives shall be included in the submittals and not used until accepted by the Engineer. When detergents or additives are used, the surface shall be rinsed with potable water before the detergent water dries.

After washing has been accepted by the Engineer, all traces of asphaltic cement, oil, grease, diesel fuel deposits, and other soluble contaminants which remain on the steel surfaces to be painted shall be removed by solvent cleaning according to SSPC – SP1, supplemented with scraping (e.g., to remove large deposits of asphaltic cement) as required. The solvent(s) used for cleaning shall be compatible with the existing coating system. The Contractor shall identify the proposed solvent(s) in the submittals. If the existing coating is softened, wrinkled, or shows other signs of attack from the solvents, the Contractor shall immediately discontinue their use. The name and composition of replacement solvents, together with MSDS, shall be submitted for Engineer acceptance prior to use.

Under no circumstances shall subsequent hand/power tool cleaning be performed in areas containing surface contaminants or in areas where the Engineer has not accepted the washing and solvent cleaning. Surfaces prepared by hand/power tool cleaning without approval of the washing and solvent cleaning may be rejected by the Engineer. Rejected surfaces shall be recleaned with both solvent and the specified mechanical means at the Contractor's expense.

After all washing and mechanical cleaning are completed, representative areas of the existing coating shall be tested to verify that the surface is free of chalk and other loose surface debris or foreign matter. The testing shall be performed according to ASTM D4214. Cleaning shall continue until a chalk rating of 6 or better is achieved in every case.

- b) Water Cleaning of Non-Lead Coatings Prior to Overcoating. Thoroughly clean the surfaces according to the steps defined above for "Water Cleaning of Lead Containing Coatings Prior to Overcoating," except that the wash water does not need to be collected, and if the shop primer is inorganic zinc, the chalk rating does not apply. All other provisions are applicable.
- c) Water Cleaning/Debris Removal Prior to Total Coating Removal. When total coating removal is specified, water cleaning of the surface prior to coating removal is not required by this specification and is at the option of the Contractor. If the Contractor chooses to use water cleaning, and the existing coating contains lead, all water and debris shall be collected for proper disposal.

Whether or not the surfaces are pre-cleaned using water, the tops of the pier caps and abutments shall be cleaned free of dirt, paint chips, insect and animal nests, bird droppings and other foreign matter and the debris collected for proper disposal.

Prior to mechanical cleaning, oil, grease, and other soluble contaminants on bare steel or rusted surfaces shall be removed by solvent cleaning according to SSPC-SP1.

- d) Water Cleaning Between Coats. When foreign matter has accumulated on a newly applied coat, washing shall be performed prior to the application of subsequent coats. The water does not need to be collected unless it contacts existing lead containing coatings.

Laminar and Stratified Rust. All laminar and stratified rust that has formed on the existing steel surfaces shall be removed. Pack rust formed along the perimeter of mating surfaces of connected plates or shapes of structural steel shall be removed to the extent feasible without mechanically detaching the mating surface. Any pack rust remaining after cleaning the mating surfaces shall be tight and intact when examined using a dull putty knife. The tools used to remove these corrosion products shall be identified in the submittals and accepted by the Engineer. If the surface preparation or removal of rust results in nicks or gouges, the work shall be suspended, and the damaged areas repaired to the satisfaction of the Engineer, at the Contractor's expense. The Contractor shall also demonstrate that he/she has made the necessary adjustments to prevent a reoccurrence of the damage prior to resuming work.

Surface Preparation (HOLD POINT). One or more of the following methods of surface preparation shall be used as specified on the plans. When a method of surface preparation is specified, it applies to the entire surface, including areas that may be concealed by the containment connection points. In each case, as part of the surface preparation process, soluble salts shall be remediated as specified under "Soluble Salt Remediation". The Contractor shall also note that the surface of the steel beneath the existing coating system may contain corrosion and/or mill scale. Removal of said corrosion and/or mill scale, when specified, shall be considered included in this work and no extra compensation will be allowed.

When a particular cleaning method is specified for use in distinct zones on the bridge, the cleaning shall extend into the existing surrounding paint until a sound border is achieved. The edge of the existing paint is considered to be sound and intact if it can not be lifted by probing the edge with a dull putty knife. The sound paint shall be feathered for a minimum of 1 1/2 in. (40 mm) to achieve a smooth transition between the prepared steel and the existing coatings. Sanders with vacuum attachments, which have been approved by the Engineer, shall be used as necessary to accomplish the feathering.

- a) Limited Access Areas: A best effort with the specified methods of cleaning shall be performed in limited access areas such as the backsides of rivets inside built up box members. The equipment being used for the majority of the cleaning may need to be supplemented with other commercially available equipment, such as angle nozzles, to properly clean the limited access areas. The acceptability of the best effort cleaning in these areas is at the sole discretion of the Engineer.
- b) Near White Metal Blast Cleaning: This surface preparation shall be accomplished according to the requirements of Near White Metal Blast Cleaning SSPC-SP 10. The designated surfaces shall be prepared by dry abrasive blast cleaning, wet abrasive blast cleaning, or water jetting with abrasive injection. A Near White Metal Blast Cleaned surface, when viewed without magnification, shall be free of all visible oil, grease, dirt, dust, mill scale, rust, paint, oxides, corrosion products, and other foreign matter, except for staining.

Random staining shall be limited to no more than 5 percent of each 9 sq. in. (58 sq. cm) of surface area and may consist of light shadows, slight streaks, or minor discoloration caused by stains of rust, stains of mill scale, or stains of previously applied paint. With the exception of crevices as defined below, surface discoloration is considered to be a residue that must be removed, rather than a stain, if it possesses enough mass or thickness that it can be removed as a powder or in chips when scraped with a pocketknife.

A surface profile shall be created on the steel as defined later under "Surface Profile."

At the discretion of the Engineer, after a best effort cleaning, slight traces of existing coating may be permitted to remain within crevices such as those created between rivets, bolts, and plates, and the underlying steel. When traces of coating are permitted to remain, the coating shall be tightly bonded when examined by probing with a dull putty knife. The traces of coating shall be confined to the bottom portion of the crevices only, and shall not extend onto the surrounding steel or plate or onto the outer surface of the rivets or bolts. Pitted steel is excluded from exemption considerations and shall be cleaned according to SSPC-SP10.

If hackles or slivers are visible on the steel surface after cleaning, the Contractor shall remove them by grinding followed by reblast cleaning. At the discretion of the Engineer, the use of power tools to clean the localized areas after grinding, and to establish a surface profile acceptable to the coating manufacturer, can be used in lieu of blast cleaning.

If the surfaces are prepared using wet abrasive methods, attention shall be paid to tightly configured areas to assure that the preparation is thorough. After surface preparation is completed, the surfaces, surrounding steel, and containment materials/scaffolding shall be rinsed to remove abrasive dust and debris. Potable water shall be used for all operations. An inhibitor may be added to the supply water and/or rinse water to prevent flash rusting. If a rust inhibitor is proposed, the Contractor shall provide a sample of the proposed inhibitor together with a letter from the coating manufacturer indicating that the inhibitor is suitable for use with their products. The surfaces shall be allowed to completely dry before the application of any coating.

- c) Commercial Grade Power Tool Cleaning: This surface preparation shall be accomplished according to the requirements of Commercial Grade Power Tool Cleaning, SSPC-SP15. The designated surfaces shall be completely cleaned with power tools. A Commercial Grade Power Tool Cleaned surface, when viewed without magnification, is free of all visible oil, grease, dirt, rust, coating, oxides, mill scale, corrosion products, and other foreign matter, except for staining. In previously pitted areas, slight residues of rust and paint may also be left in the bottoms of pits.

Random staining shall be limited to no more than 33 percent of each 9 sq. in. (58 sq. cm) of surface area. Allowable staining may consist of light shadows, slight streaks, or minor discoloration caused by stains of rust, stains of mill scale, or stains of previously applied paint. Surface discoloration is considered to be a residue that must be removed, rather than a stain, if it possesses enough mass or thickness that it can be removed as a powder or in chips when scraped with a pocketknife.

A surface profile shall be created on the steel as defined later under "Surface Profile."

At the Contractor's option, Near White Metal Blast Cleaning may be substituted for Power Tool Cleaning – Commercial Grade, as long as containment systems appropriate for abrasive blast cleaning are utilized and there is no additional cost to the Department.

- d) Power Tool Cleaning – Modified SP3: This surface preparation shall be accomplished according to the requirements of SSPC-SP3, Power Tool Cleaning except as modified as follows. The designated surfaces shall be cleaned with power tools. A power tool cleaned surface shall be free of all loose rust, loose mill scale, loose and peeling paint, and loose rust that is bleeding through and/or penetrating the coating. All locations of visible corrosion and rust bleed, exposed or lifting mill scale, and lifting or loose paint shall be prepared using the power tools.

Upon completion of the cleaning, rust, rust bleed, mill scale and surrounding paint are permitted to remain if they cannot be lifted using a dull putty knife.

Power Tool Cleaning of Shop Primed Steel. When steel coated with only a prime coat of inorganic or organic zinc is specified to be cleaned, this work shall be accomplished as follows. After cleaning the surface as specified under "Water Cleaning of Non-Lead Coatings Prior to Overcoating," damaged and rusted areas shall be spot cleaned according Power Tool Cleaning -Modified SSPC-SP3. The edges of the coating surrounding the spot repairs shall be feathered.

Abrasives. When abrasive blast cleaning is specified, it shall be performed using either expendable abrasives (other than silica sand) or recyclable steel grit abrasives. Expendable abrasives shall be used one time and disposed of. Abrasive suppliers shall certify that the expendable abrasives meet the requirements of SSPC-AB1 and that recyclable steel grit abrasives meet AB3. On a daily basis, the Contractor shall verify that recycled abrasives are free of oil contamination by conducting oil content tests according to SSPC-AB2.

All surfaces prepared with abrasives not meeting the SSPC-AB1, AB2, or AB3 requirements, as applicable, shall be solvent cleaned or low pressure water cleaned as directed by the Engineer, and reblast cleaned at the Contractor's expense.

Surface Profile (HOLD POINT). The abrasives used for blast cleaning shall have a gradation such that the abrasive will produce a uniform surface profile of 1.5 to 4.5 mils (38 to 114 microns). If the profile requirements of the coating manufacturer are more restrictive, advise the Engineer and comply with the more restrictive requirements. For recycled abrasives, an appropriate operating mix shall be maintained in order to control the profile within these limits.

The surface profile for the Power Tool Cleaning - Commercial Grade shall be within the range specified by the coating manufacturer, but not less than 2.0 mils (50 microns).

The surface profile produced by the Contractor's surface preparation procedures shall be determined by replica tape and spring micrometer at the beginning of the work, and each day that surface preparation is performed. Areas having unacceptable measurements shall be further tested to determine the limits of the deficient area. The replica tape shall be attached to the daily report.

When unacceptable profiles are produced, work shall be suspended. The Contractor shall submit a plan for the necessary adjustments to insure that the correct surface profile is achieved on all surfaces. The Contractor shall not resume work until the new profile is verified by the QA observations, and the Engineer confirms, in writing, that the profile is acceptable.

Soluble Salt Remediation (HOLD POINT). The Contractor shall implement surface preparation procedures and processes that will remove chloride from the surfaces. Surfaces that may be contaminated with chloride include, but are not limited to, expansion joints and all areas that are subject to roadway splash or run-off such as fascia beams and stringers.

Methods of chloride removal may include, but are not limited to, steam cleaning or pressure washing with or without the addition of a chemical soluble salt remover as approved by the coating manufacturer, and scrubbing before or after initial paint removal. The Contractor may also elect to clean the steel and allow it to rust overnight followed by recleaning, or by utilizing blends of fine and coarse abrasives during blast cleaning, wet abrasive/water jetting methods of preparation, or combinations of the above. If steam or water cleaning methods of chloride removal are utilized over surfaces where the coating has been completely removed, and the water does not contact any lead containing coatings, the water does not have to be collected.

The Contractor shall provide the proposed procedures for chloride remediation in the Surface Preparation/Painting Plan.

Upon completion of the chloride remediation steps, the Contractor shall use cell methods of field chloride extraction and test procedures (e.g., silver dichromate) accepted by the Engineer, to test representative surfaces that were previously rusted (e.g., pitted steel) for the presence of remaining chlorides. Remaining chloride levels shall be no greater than $7\mu\text{g}/\text{sq cm}$ as read directly from the surface without any multiplier applied to the results. The testing must be performed, and the results must be acceptable, prior to painting each day.

A minimum of 5 tests per 1000 sq. ft. (93 sq m) or fraction thereof completed in a given day, shall be conducted at project start up. If results greater than $7\mu\text{g}/\text{sq cm}$ are detected, the surfaces shall be recleaned and retested at the same frequency. If acceptable results are achieved on three consecutive days in which testing is conducted, the test frequency may be reduced to 1 test per 1000 sq. ft. (93 sq. m) prepared each day provided the chloride remediation process remains unchanged. If unacceptable results are encountered, or the methods of chloride remediation are changed, the Contractor shall resume testing at a frequency of 5 tests per 1000 sq. ft. (93 sq. m).

Following successful chloride testing the chloride test areas shall be cleaned. Commercial Grade Power Tool Cleaning can be used to clean the test locations when the specified degree of cleaning is SSPC-SP10.

Surface Condition Prior to Painting (HOLD POINT). Prepared surfaces, shall meet the requirements of the respective degrees of cleaning immediately prior to painting, and shall be painted before rusting appears on the surface. If rust appears or bare steel remains unpainted for more than 12 hours, the affected area shall be prepared again at the expense of the Contractor.

All loose paint and surface preparation cleaning residue on bridge steel surfaces, scaffolding and platforms, containment materials, and tops of abutments and pier caps shall be removed prior to painting. When lead paint is being disturbed, cleaning shall be accomplished by HEPA vacuuming unless it is conducted within a containment that is designed with a ventilation system capable of collecting the airborne dust and debris created by sweeping and blowing with compressed air.

The quality of surface preparation and cleaning of surface dust and debris must be accepted by the Engineer prior to painting. The Engineer has the right to reject any work that was performed without adequate provision for QA observations to accept the degree of cleaning. Rejected coating work shall be removed and replaced at the Contractor's expense.

General Paint Requirements. Paint storage, mixing, and application shall be accomplished according to these specifications and as specified in the paint manufacturer's written instructions and product data sheets for the paint system used. In the event of a conflict between these specifications and the coating manufacturers' instructions and data sheets, the Contractor shall advise the Engineer and comply with the Engineer's written resolution. Until a resolution is provided, the most restrictive conditions shall apply.

Unless noted otherwise, If a new concrete deck or repair to an existing deck is required, painting shall be done after the deck is placed and the forms have been removed.

- a) **Paint Storage and Mixing.** All Paint shall be stored according to the manufacturer's published instructions, including handling, temperatures, and warming as required prior to mixing. All coatings shall be supplied in sealed containers bearing the manufacturers name, product designation, batch number and mixing/thinning instructions. Leaking containers shall not be used.

Mixing shall be according to the manufacturer's instructions. Thinning shall be performed using thinner provided by the manufacturer, and only to the extent allowed by the manufacturer's written instructions. In no case shall thinning be permitted that would cause the coating to exceed the local Volatile Organic Compound (VOC) emission restrictions. For multiple component paints, only complete kits shall be mixed and used. Partial mixing is not allowed.

The ingredients in the containers of paint shall be thoroughly mixed by mechanical power mixers according to the manufacturer's instructions, in the original containers before use or mixing with other containers of paint. The paint shall be mixed in a manner that will break up all lumps, completely disperse pigment and result in a uniform composition. Paint shall be carefully examined after mixing for uniformity and to verify that no unmixed pigment remains on the bottom of the container. Excessive skinning or partial hardening due to improper or prolonged storage will be cause for rejection of the paint, even though it may have been previously inspected and accepted.

Multiple component coatings shall be discarded after the expiration of the pot life. Single component paint shall not remain in spray pots, painters buckets, etc. overnight. It shall be stored in a covered container and remixed before use.

The Engineer reserves the right to sample field paint (individual components and/or the mixed material) and have it analyzed. If the paint does not meet the product requirements due to excessive thinning or because of other field problems, the coating shall be removed from that section of the structure and replaced as directed by the Engineer.

- b) **Application Methods.** Unless prohibited by the coating manufacturer's written instructions, paint may be applied by spray methods, rollers, or brushes. If applied with conventional or airless spray methods, paint shall be applied in a uniform layer with overlapping at the edges of the spray pattern.

The painters shall monitor the wet film thickness of each coat during application. The wet film thickness shall be calculated based on the solids by volume of the material and the amount of thinner added. When the new coating is applied over an existing system, routine QC inspections of the wet film thickness shall be performed in addition to the painter's checks in order to establish that a proper film build is being applied.

When brushes or rollers are used to apply the coating, additional applications may be required to achieve the specified thickness per layer.

- c) **Painting Shop Primed Steel.** After cleaning, rusted and damaged areas shall be touched up using the same primer specified for painting the existing structure. The intermediate and finish coats specified for painting the existing structure shall be applied to the steel.

When inorganic zinc has been used as the shop primer, a mist coat of the intermediate coat shall be applied first in order to prevent pinholing and bubbling.

- d) Recoating and Film Continuity (HOLD POINT for each coat). Paint shall be considered dry for recoating according to the time/temperature/humidity criteria provided in the manufacturer's instructions and when an additional coat can be applied without the development of film irregularities; such as lifting, wrinkling, or loss of adhesion of the under coat. If surfaces are contaminated, washing shall be accomplished prior to intermediate and final coats. Wash water does not have to be collected unless the water contacts existing lead containing coatings.

Painting shall be done in a neat and workmanlike manner. Each coat of paint shall be applied as a continuous film of uniform thickness free of defects including, but not limited to, runs, sags, overspray, dryspray, pinholes, voids, skips, misses, and shadow-through. Defects such as runs and sags shall be brushed out immediately during application.

Paint Systems. The paint system(s) from the list below shall be applied as specified.

The paint manufacturer's relative humidity, dew point, and material, surface, and ambient temperature restrictions shall be provided with the submittals and shall be strictly followed. Written recommendations from the paint manufacturer for the length of time each coat must be protected from cold or inclement weather (e.g., exposure to rain), during the drying period shall be included in the submittals. Upon acceptance by the Engineer, these times shall be used to govern the duration that protection must be maintained during drying.

Where stripe coats are indicated, the Contractor shall apply an additional coat to edges, rivets, bolts, crevices, welds, and similar surface irregularities. The stripe coat shall be applied by brush and/or spray to thoroughly work the coating into or on the irregular surfaces, and shall extend onto the surrounding steel a minimum of 1 in. (25 mm) in all directions. The purpose of the stripe coat is to build additional thickness and to assure complete coverage of these areas.

The stripe coat may be applied as part of the application of the full coat unless prohibited by the coating manufacturer. If applied as part of the application process of the full coat, the stripe coat shall be allowed to dry for a minimum of 10 minutes in order to allow Contractor QC personnel to verify that the coat was applied. If a wet-on-wet stripe coat is prohibited by the coating manufacturer or brush or roller application of the full coat pulls the underlying stripe coat, the stripe coat shall dry according to the manufacturers' recommended drying times prior to the application of the full coat. In the case of the prime coat, the full coat can also be applied first to protect the steel, followed by the stripe coat after the full coat has dried.

- a) System 1 – OZ/E/U – for Bare Steel: System 1 shall consist of the application of a full coat of organic (epoxy) zinc-rich primer, a full intermediate coat of epoxy, and a full finish coat of aliphatic urethane. Stripe coats of the prime and finish coats shall be applied. The film thicknesses of the full coats shall be as follows, measured according to SSPC-PA2:
- One full coat of organic zinc-rich primer between 3.5 and 5.0 mils (90 and 125 microns) dry film thickness. The prime coat shall be tinted to a color that contrasts with the steel surface.

- One full intermediate coat of epoxy between 3.0 and 6.0 mils (75 and 150 microns) dry film thickness. The intermediate coat shall be a contrasting color to both the first coat and finish coat.
- One full finish coat of aliphatic urethane between 2.5 and 4.0 mils (65 and 100 microns) dry film thickness. Finish coat color shall be according to contract plans.

The total dry film thickness for this system, exclusive of areas receiving the stripe coats, shall be between 9.0 and 15.0 mils (225 and 375 microns).

- b) System 2 – PS/EM/U – for Overcoating an Existing System: System 2 shall consist of the application of a full coat of epoxy penetrating sealer, a spot intermediate coat of aluminum epoxy mastic and a stripe and full finish coat of aliphatic urethane.

A full coat of epoxy penetrating sealer shall be applied to all surfaces following surface preparation. A spot intermediate coat shall consist of the application of one coat of the aluminum epoxy mastic on all areas where rust is evident and areas where the old paint has been removed, feathered and/or damaged prior to, during or after the cleaning and surface preparation operations. After the spot intermediate, a stripe coat and full finish coat of aliphatic urethane shall be applied. The film thicknesses shall be as follows, measured according to SSPC-PA2:

- One full coat of epoxy penetrating sealer between 1.0 and 2.0 mils (25 and 50 microns) dry film thickness.
- One spot coat of aluminum epoxy mastic between 5.0 and 7.0 mils (125 and 175 microns) dry film thickness. The color shall contrast with the finish coat.
- One full finish coat of aliphatic urethane between 2.5 and 4.0 mils (65 and 100 microns) dry film thickness. Finish coat color shall be according to contract plans.

The total dry film thickness for this system, exclusive of the stripe coat, shall be between 8.5 and 13.0 mils (215 and 325 microns). The existing coating thickness to remain under the overcoat must be verified in order to obtain accurate total dry film thickness measurements.

- c) System 3 – EM/EM/AC – for Bare Steel: System 3 shall consist of the application of two full coats of aluminum epoxy mastic and a full finish coat of waterborne acrylic. Stripe coats for first coat of epoxy mastic and the finish coat shall be applied. The film thicknesses of the full coats shall be as follows, measured according to SSPC-PA2:

- One full coat of aluminum epoxy mastic between 5.0 and 7.0 mils (125 and 175 microns) dry film thickness. The first coat of aluminum epoxy mastic shall be tinted a contrasting color with the blast cleaned surface and the second coat.
- One full intermediate coat of aluminum epoxy mastic between 5.0 and 7.0 mils (125 and 175 microns) dry film thickness. The intermediate coat shall be a contrasting color to the first coat and the finish coat.

- A full finish coat of waterborne acrylic between 2.0 and 4.0 mils (50 and 100 microns) dry film thickness. Finish coat color shall be according to contract plans.

The total dry film thickness for this system, exclusive of areas receiving the stripe coats, shall be between 12.0 and 18.0 mils (360 and 450 microns).

- d) System 4 – PS/EM/AC – for Overcoating an Existing System: System 4 shall consist of the application of a full coat of epoxy penetrating sealer, a spot intermediate coat of aluminum epoxy mastic and a stripe and full finish coat of waterborne acrylic.

A full coat of epoxy penetrating sealer shall be applied to all surfaces following surface preparation. A spot intermediate coat shall consist of the application of one coat of the aluminum epoxy mastic on all areas where rust is evident and areas where the old paint has been removed, feathered and/or damaged prior to, during or after the cleaning and surface preparation operations. After the spot intermediate, a stripe coat and full finish coat of waterborne acrylic shall be applied. The film thicknesses shall be as follows, measured according to SSPC-PA2:

- One full coat of epoxy penetrating sealer between 1.0 and 2.0 mils (25 and 50 microns) dry film thickness.
- One spot coat of aluminum epoxy mastic between 5.0 and 7.0 mils (125 and 175 microns) dry film thickness. The color shall contrast with the finish coat.
- One full finish coat of waterborne acrylic between 2.0 and 4.0 mils (50 and 100 microns) dry film thickness. Finish coat color shall be according to contract plans.

The total dry film thickness for this system, exclusive of the stripe coat, shall be between 8.0 and 13.0 mils (200 and 325 microns). The existing coating thickness to remain under the overcoat must be verified in order to obtain accurate total dry film thickness measurements.

- e) System 5 – MCU – for Bare Steel: System 5 shall consist of the application of a full coat of moisture cure urethane (MCU) zinc primer, a full coat of MCU intermediate, and a full coat of MCU finish. Stripe coats of the prime and finish coats shall be applied. The contractor shall comply with the manufacturer's requirements for drying times between the application of the stripe coats and the full coats. The film thicknesses of the full coats shall be as follows, measured according to SSPC-PA2:

- One full coat of MCU zinc primer between 3.0 and 5.0 mils (75 and 125 microns) dry film thickness. The prime coat shall be tinted to a color that contrasts with the steel surface.
- One full MCU intermediate coat between 3.0 and 4.0 mils (75 and 100 microns) dry film thickness. The intermediate coat shall be a contrasting color to both the first coat and finish coat.

- One full MCU finish coat between 2.0 and 4.0 mils (50 and 100 microns) dry film thickness. Finish coat color shall be according to contract plans.

The total dry film thickness for this system, exclusive of areas receiving the stripe coats, shall be between 8.0 and 13.0 mils (200 and 325 microns).

- f) System 6 – MCU – for Overcoating an Existing System: System 6 shall consist of the application of a full coat of moisture cure urethane (MCU) penetrating sealer, a spot coat of MCU intermediate, and a stripe and full coat of MCU finish.

A full coat of MCU penetrating sealer shall be applied to all surfaces following surface preparation. A spot intermediate coat shall consist of the application of one coat of MCU intermediate on all areas where rust is evident and areas where the old paint has been removed, feathered and/or damaged prior to, during or after the cleaning and surface preparation operations. After the spot intermediate, a stripe coat and full coat of MCU finish shall be applied. The contractor shall comply with the manufacturer's requirements for drying time between the application of the stripe coat and the full finish coat. The film thicknesses shall be as follows, measured according to SSPC-PA2:

- One full coat of MCU sealer between 1.0 and 2.0 mils (25 and 50 microns) dry film thickness.
- One full MCU intermediate coat between 3.0 and 4.0 mils (75 and 100 microns) dry film thickness. The color shall contrast with the finish coat.
- One full MCU finish coat 2.0 and 4.0 mils (50 and 100 microns) dry film thickness. Finish coat color shall be according to contract plans.

The total dry film thickness for this system, exclusive of areas receiving the stripe coats, shall be between 6.0 and 10.0 mils (150 and 250 microns). The existing coating thickness to remain under the overcoat must be verified in order to obtain accurate total dry film thickness measurements.

Repair of Damage to New Coating System and Areas Concealed by Containment. The Contractor shall repair all damage to the newly installed coating system and areas concealed by the containment/protective covering attachment points, at no cost to the Department. If the damage extends to the substrate and the original preparation involved abrasive blast cleaning, the damaged areas shall be prepared to Power Tool Cleaning - Commercial Grade. If the original preparation was other than blast cleaning or the damage does not extend to the substrate, the loose, fractured paint shall be cleaned to Power Tool Cleaning – Modified SP3.

The surrounding coating at each repair location shall be feathered for a minimum distance of 1 1/2 in. (40 mm) to achieve a smooth transition between the prepared areas and the existing coating.

If the bare steel is exposed, all coats shall be applied to the prepared area. If only the intermediate and finish coats are damaged, the intermediate and finish shall be applied. If only the finish coat is damaged, the finish shall be applied.

Special Instructions.

- a) At the completion of the work, the Contractor shall stencil the painting date and the paint code on the bridge. The letters shall be capitals, not less than 2 in. (50 mm) and not more than 3 in. (75 mm) in height.

The stencil shall contain the following wording "PAINTED BY (insert the name of the Contractor)" and shall show the month and year in which the painting was completed, followed by the appropriate code for the coating material applied, all stenciled on successive lines:

CODE U (for field applied System 3 or System 4).

CODE Z (for field applied System 1 or System 2).

CODE AA (for field applied System 5 or System 6).

This information shall be stenciled on the cover plate of a truss end post near the top of the railing, or on the outside face of an outside stringer near one end of the bridge, or at some equally visible surface near the end of the bridge, as designated by the Engineer.

- b) All surfaces painted inadvertently shall be cleaned immediately.

It is understood and agreed that the cost of all work outlined above, unless otherwise specified, has been included in the bid, and no extra compensation will be allowed.

Basis of Payment. This work shall be paid for at the contract Lump Sum price for CLEANING AND PAINTING STEEL BRIDGE, at the designated location, or for CLEANING AND PAINTING the structure or portions thereof described. Payment will not be authorized until all requirements for surface preparation and painting have been fulfilled as described in this specification, including the preparation and submittal of all QC documentation. Payment will also not be authorized for non-conforming work until the discrepancy is resolved in writing.

Appendix 1 – Reference List

The Contractor shall maintain the following regulations and references on site for the duration of the project:

- Illinois Environmental Protection Act
- ASTM D 4214, Standard Test Method for Evaluating Degree of Chalking of Exterior Paint Films
- ASTM D 4285, Standard Test Method for Indicating Oil or Water in Compressed Air
- SSPC-AB 1, Mineral and Slag Abrasives
- SSPC-AB 2, Specification for Cleanliness of Recycled Ferrous Metallic Abrasives
- SSPC-AB 3, Newly Manufactured or Re-Manufactured Steel Abrasives
- SSPC-PA 2, Measurement of Dry Coating Thickness with Magnetic Gages
- SSPC-QP 1, Standard Procedure for Evaluating Painting Contractors (Field Application to Complex Structures)

- SSPC-QP 2, Standard Procedure for Evaluating the Qualifications of Painting Contractors to Remove Hazardous Paint
- SSPC-SP 1, Solvent Cleaning
- SSPC-SP 3, Power Tool Cleaning
- SSPC-SP 10/NACE No. 2, Near White Metal Blast Cleaning
- SSPC-SP 12/NACE No. 5, Surface Preparation and Cleaning of Metals by Waterjetting Prior to Recoating
- SSPC-SP15, Commercial Grade Power Tool Cleaning
- SSPC-VIS 1, Guide and Reference Photographs for Steel Surfaces Prepared by Dry Abrasive Blast Cleaning
- SSPC-VIS 3, Visual Standard for Power- and Hand-Tool Cleaned Steel
- SSPC-VIS 4, Guide and Reference Photographs for Steel Cleaned by Water Jetting
- SSPC-VIS 5, Guide and Reference Photographs for Steel Prepared by Wet Abrasive Blast Cleaning
- The paint manufacturer's application instructions, MSDS and product data sheets

DECK SLAB REPAIR

Effective: May 15, 1995

Revised: January 22, 2010

This work shall consist of hot-mix asphalt surface removal, when required, the removal and disposal of all loose and deteriorated concrete from bridge deck and the replacement with new concrete to the original top of deck. The work shall be done according to the applicable requirements of Sections 501, 503 and 1020 of the Standard Specifications and this Special Provision.

Deck slab repairs will be classified as follows:

- (a) Partial-Depth. Partial-depth repairs shall consist of removing the loose and unsound deck concrete, disposing of the concrete removed and replacing with new concrete. The removal may be performed by chipping with power driven hand tools or by hydro-scarification equipment. The depth shall be measured from the top of the concrete deck surface, at least 3/4 in. (20 mm) but not more than 1/2 the concrete deck thickness.
- (b) Full-Depth. Full-depth repairs shall consist of removing concrete full-depth of the deck, disposing of the concrete removed, and replacing with new concrete to the original concrete deck surface. The removal may be performed with power driven hand tools, hydraulic impact equipment, or by hydro-scarification equipment. Full-depth repairs shall be classified for payment as Full-Depth, Type I and Full-Depth, Type II according to the following:

Type I Full-depth patches less than or equal to 5 sq. ft. (0.5 sq m) in area. The minimum dimensions for a patch shall be 1 ft. x 1 ft. (300 mm x 300 mm).

Type II Full-depth patches greater than 5 sq. ft. (0.5 sq. m) in area.

Materials.

Materials shall be according to Article 1020.02.

Portland cement concrete for partial and full-depth repairs shall be according to Section 1020. Class PP-1, PP-2, PP-3, PP-4, PP-5 or BS concrete shall be used at the Contractor's option unless noted otherwise on the contract plans. For Class BS concrete, a CA 13, 14, or 16 shall be used. If the BS concrete mixture is used only for full depth repairs, a CA-11 may be used. In Section 1020, revise the second sentence of Note 10 for Table 1 of Article 1020.04 to read as follows for Class PP concrete: "The bridge deck patching mix design strength shall be increased to 4000 psi (27,500 kPa) compressive or 675 psi (4650 kPa) flexural, and the mixture shall have 72 hours to obtain the required strength."

Grout. The grout for bonding new concrete to old concrete shall be proportioned by weight (mass) and mixed at the job site, or it may be ready-mixed if agitated while at the job site. The bonding grout shall consist of one part portland cement and one part sand, mixed with sufficient water to form a slurry. The bonding grout shall have a consistency allowing it to be scrubbed onto the prepared surface with a stiff brush or broom leaving a thin, uniform coating that will not run or puddle in low spots. Grout that cannot be easily and evenly applied or has lost its consistency may be rejected by the Engineer. Grout that is more than two hours old shall not be used.

Equipment:

The equipment used shall be subject to the approval of the Engineer and shall meet the following requirements:

- (a) Surface Preparation Equipment. Surface preparation and concrete removal equipment shall be according to the applicable portions of Section 1100 and the following:
 - (1) Sawing Equipment. Sawing equipment shall be a concrete saw capable of sawing concrete to the specified depth.
 - (2) Blast Cleaning Equipment. The blast cleaning may be performed by wet sandblasting, high-pressure waterblasting, shotblasting or abrasive blasting. Blast cleaning equipment shall be capable of removing rust and old concrete from exposed reinforcement bars, and shall have oil traps.
 - (3) Power-Driven Hand Tools. Power-driven hand tools will be permitted including jackhammers lighter than the nominal 45 lb. (20 kg) class. Chipping hammers heavier than a nominal 15 lb. (6.8 kg) class shall not be used for removing concrete from below any reinforcing bar for partial depth repairs, or for removal within 1 ft (300 mm) of existing beams, girders or other supporting structural members that are to remain in service or within 1 ft (300 mm) of the boundaries of full-depth repairs. Jackhammers or chipping hammers shall not be operated at an angle in excess of 45 degrees measured from the surface of the slab.
 - (4) Hydraulic Impact Equipment. Hydraulic impact equipment with a maximum rated striking energy of 360 ft-lbs (270 J) may be permitted only in areas of full depth removal more than 1 ft (300 mm) away from existing beams, girders or other supporting structural members that are to remain in service or more than 1 ft (300 mm) from the boundaries of full-depth repairs.

(5) Hydro-Scarification Equipment. The hydro-scarification equipment shall consist of filtering and pumping units operating with a remote-controlled robotic device. The equipment may use river, stream or lake water. Operation of the equipment shall be performed and supervised by qualified personnel certified by the equipment manufacturer. Evidence of certification shall be presented to the Engineer. The equipment shall be capable of removing concrete to the specified depth and removing rust and concrete particles from exposed reinforcing bars. Hydro-scarification equipment shall be calibrated before being used and shall operate at a minimum of 18,000 psi (124 MPa).

(b) Concrete Equipment: Equipment for proportioning and mixing the concrete shall be according to Article 1020.03.

(c) Finishing Equipment: Finishing equipment shall be according to Article 1103.17. Adequate hand tools will be permitted for placing and consolidating concrete in the patch areas and for finishing small patches.

Construction Requirements: Sidewalks, curbs, drains, reinforcement and/or existing transverse and longitudinal joints which are to remain in place shall be protected from damage during removal and cleaning operations. All damage caused by the Contractor shall be corrected, at the Contractor's expense, to the satisfaction of the Engineer.

The Contractor shall control the runoff water generated by the various construction activities in such a manner as to minimize, to the maximum extent practicable, the discharge of construction debris into adjacent waters, and shall properly dispose of the solids generated according to Article 202.03. Runoff water will not be allowed to constitute a hazard on adjacent or underlying roadways, waterways, drainage areas or railroads nor be allowed to erode existing slopes.

(a) Hot-Mix Asphalt Surface Removal.

The hot-mix asphalt surface course and all waterproofing membrane shall be removed and disposed of according to applicable portions of Articles 440.04 and 440.06, except milling equipment will not be allowed if the deck is to receive a waterproofing membrane system. If the overlay or waterproofing membrane contains asbestos fibers, removal shall be in accordance with the Special Provision for "Asbestos Waterproofing Membrane or Asbestos Hot-mix Asphalt Surface Removal". Removal of the hot-mix asphalt surface by the use of radiant or direct heat will not be permitted.

(b) Surface Preparation:

All loose, disintegrated and unsound concrete shall be removed from portions of the deck slab shown on the plans or as designated by the Engineer. The Engineer will determine the limits of removal as the work progresses.

The Contractor shall take care not to damage reinforcement bars or expansion joints which are to remain in place. Any damage to reinforcement bars or expansion joints shall be corrected at the Contractor's expense. All loose reinforcement bars, as determined by the Engineer, shall be retied at the Contractor's expense.

- (1) Partial-Depth. Areas to be repaired will be determined and marked by the Engineer. A concrete saw shall be used to provide vertical edges approximately 3/4 in. (20 mm) deep around the perimeter of the area to be patched when a concrete overlay is not specified. Where high steel is present, the depth may be reduced as directed by the Engineer. A saw cut will not be required on those boundaries along the face of the curb, parapet or joint or when sharp vertical edges are provided by hydro-scarification.

The loose and unsound concrete shall be removed by chipping, with power driven hand tools or by hydro-scarification equipment. All exposed reinforcing bars and newly exposed concrete shall be thoroughly blast cleaned. Where, in the judgment of the Engineer, the bond between existing concrete and reinforcement steel within the patch area has been destroyed, the concrete adjacent to the bar shall be removed to a depth that will permit new concrete to bond to the entire periphery of the exposed bar. A minimum of 1 in. (25 mm) clearance will be required. The Engineer may require enlarging a designated removal area should inspection indicate deterioration beyond the limits previously designated. In this event, a new saw cut shall be made around the extended area before additional removal is begun. The removal area shall not be enlarged solely to correct debonded reinforcement or deficient lap lengths.

- (2) Full-Depth. Concrete shall be removed as determined by the Engineer within all areas designated for full-depth repair and in all designated areas of partial depth repair in which unsound concrete is found to extend below half the concrete deck thickness. Full depth removal shall be performed according to Article 501.05 except that hydraulic impact equipment may be permitted in areas of full depth removal more than 1 ft (300 mm) away from the edges of existing beams, girders or other supporting structural members or more than 1 ft (300 mm) from the boundaries of full-depth repairs. Saw cuts shall be made on the top of the deck, except those boundaries along the face of curbs, parapets and joints or where hydro-scarification provided sharp vertical edges. The top saw cut may be omitted if the deck is to receive an overlay.

Forms for full-depth repair may be supported by hangers with adjustable bolts or by blocking from the beams below. When approved by the Engineer, forms for Type 1 patches may be supported by No. 9 wires or other devices attached to the reinforcement bars.

All form work shall be removed after the curing sequence is complete and prior to opening to traffic.

- (3) Reinforcement Treatment. Care shall be exercised during concrete removal to protect the reinforcement bars and structural steel from damage. Any damage to the reinforcement bars or structural steel to remain in place shall be repaired or replaced to the satisfaction of the Engineer at the Contractor's expense. All existing reinforcement bars shall remain in place except as herein provided for corroded bars. Tying of loose bars will be required. Reinforcing bars which have been cut or have lost 25 percent or more of their original cross sectional area shall be supplemented by new in kind reinforcement bars. New bars shall be lapped a minimum of 32 bar diameters to existing bars.

An approved mechanical bar splice capable of developing in tension at least 125 percent of the yield strength of the existing bar shall be used when it is not feasible to provide the minimum bar lap. No welding of bars will be permitted.

- (4) Cleaning. Immediately after completion of the concrete removal and reinforcement repairs, the repair areas shall be cleaned of dust and debris. Once the initial cleaning is completed, the repair areas shall be thoroughly blast cleaned to a roughened appearance free from all foreign matter. Particular attention shall be given to removal of concrete fines. Any method of cleaning which does not consistently produce satisfactory results shall be discontinued and replaced by an acceptable method. All debris, including water, resulting from the blast cleaning shall be confined and shall be immediately and thoroughly removed from all areas of accumulation. If concrete placement does not follow immediately after the final cleaning, the area shall be carefully protected with well-anchored polyethylene sheeting.

Exposed reinforcement bars shall be free of dirt, detrimental scale, paint, oil, or other foreign substances which may reduce bond with the concrete. A tight non-scaling coating of rust is not considered objectionable. Loose, scaling rust shall be removed by rubbing with burlap, wire brushing, blast cleaning or other methods approved by the Engineer.

(c) Placement & Finishing of Concrete Repair:

- (1) Grout Placement. After the repair areas have been cleaned and immediately prior to concrete placement, the grout shall be applied to a dampened surface. A thin layer of grout shall be thoroughly scrubbed into the deck surface. All vertical as well as horizontal surfaces shall receive a thorough, even coating. The rate of grout placement shall be limited so the brushed grout does not dry out before it is covered with concrete. Grout that has become dry and chalky shall be blast cleaned and replaced at the Contractor's expense. No concrete shall be placed over dry grout.

(2) Concrete Placement.

The concrete shall be placed and consolidated according to Article 503.07 and as herein specified. Article 1020.14 shall apply.

When an overlay system is not specified, the patches shall be finished according to Article 503.16 (a), followed by a light brooming.

(d) Curing and Protection.

Concrete patches shall be cured by the Wetted Burlap or Wetted Cotton Mat Method according to Article 1020.13 (a)(3) or Article 1020.13 (a)(5). The curing period shall be 3 days for Class PP-1, PP-2, PP-3, PP-4, and PP-5 concrete. The curing period shall be 7 days for Class BS concrete. In addition to Article 1020.13, when the air temperature is less than 55° F (13° C), the Contractor shall cover the patch according to Article 1020.13 (d)(1) with minimum R12 insulation. Insulation is optional when the air temperature is 55° F. - 90° F (13° C - 32° C). Insulation shall not be placed when the air temperature is greater than 90° F (32° C).

A 72-hour minimum drying period shall be required before placing waterproofing or hot-mix asphalt surfacing.

(e) Opening to Traffic.

No traffic will be permitted on a patch until after the specified cure period, and the concrete has obtained a minimum compressive strength of 4000 psi (27.6 MPa) or flexural strength of 675 psi (4.65 MPa).

Construction equipment will be permitted on a patch during the cure period if the concrete has obtained the minimum required strength. In this instance, the strength specimens shall be cured with the patch.

Method of Measurement.

When specified, hot-mix asphalt surface removal and full or partial depth repairs will be measured for payment and computed in square yards (square meters).

Basis of Payment.

The hot-mix asphalt surface removal will be paid for at the contract unit price per square yard (square meter) for HOT-MIX ASPHALT SURFACE REMOVAL (DECK). Areas removed and replaced up to and including a depth of half the concrete deck thickness will be paid for at the contract unit price per square yard (square meter) for DECK SLAB REPAIR (PARTIAL). Areas requiring removal greater than a depth of half the concrete deck thickness shall be removed and replaced full depth and will be paid for at the contract unit price per square yard (square meter) for DECK SLAB REPAIR (FULL DEPTH, TYPE I) and/or DECK SLAB REPAIR (FULL DEPTH, TYPE II).

When corroded reinforcement bars are encountered in the performance of this work and replacement is required, the Contractor will be paid according to Article 109.04.

No payment will be allowed for removal and replacement of reinforcement bars damaged by the Contractor in the performance of his/her work or for any increases in dimensions needed to provide splices for these replacement bars.

Removal and disposal of asbestos waterproofing and/or asbestos bituminous concrete will be paid for as specified in the Special Provision for "Asbestos Waterproofing Membrane or Asbestos Hot-Mix Asphalt Surface Removal".

BRIDGE DECK MICROSILICA CONCRETE OVERLAY

Effective: May 15, 1995

Revised: May 11, 2009

Description. This work shall consist of the preparation of the existing concrete bridge deck and the construction of a microsilica concrete overlay to the specified thickness. The minimum thickness of the overlay shall be 2 1/4 in. (60 mm).

Materials. Materials shall meet the requirements of the following Articles of Section 1000:

<u>Item</u>	<u>Article/Section</u>
(a) Microsilica	1010
(b) Portland Cement Concrete (Notes 1-6)	1020
(c) Grout (Note 7)	
(d) Packaged Rapid Hardening Mortar or Concrete	1018
(e) Concrete Curing Materials	1022.02

Note 1: Cement shall be Type I portland cement. Fine aggregate shall be natural sand and the coarse aggregate shall be crushed stone or crushed gravel. The gradation of the coarse aggregate shall be CA 11, CA 13, CA 14 or CA 16.

Note 2: Mix Design Criteria.

Article 1020.04 shall not apply. The microsilica concrete mix design shall meet the following requirements:

Cement Factor	565 lb./cu. yd. (335 kg/cu. m)
Microsilica Solids	33 lb./cu. yd. (20 kg/cu. m)
Water/Cement Ratio (including water in the slurry)	0.37 to 0.41
Mortar Factor	0.88 to 0.92
Slump	3 to 6 in. (75 to 150 mm)
Air Content	5.0 to 8.0 percent
Compressive Strength (14 days)	4000 psi (27,500 kPa) minimum
Flexural Strength (14 days)	675 psi (4,650 kPa) minimum

Note 3: Admixtures.

Article 1020.05(b) shall apply except as follows:

High-range water reducing admixtures (superplasticizers) shall be added as determined by the Engineer.

Note 4: Fly Ash.

Article 1020.05(c)(1) shall apply except as follows:

Only Class C fly ash may be used to partially replace portland cement. The amount of cement replaced and replacement ratio shall be the same as for Class BS concrete.

Note 5: Ground Granulated Blast-Furnace Slag.

Ground granulated blast-furnace slag may be used according to Article 1020.05(c)(2). The amount of cement replaced and replacement ratio shall be the same as for Class BS concrete.

Note 6: Mixing.

The mixing requirements shall be according to Article 1020.11, except as follows:

(a) Water-based microsilica slurry:

(1) Truck Mixer:

- Combine simultaneously air entraining admixture, water-reducing admixture and/or retarding admixture, microsilica slurry and 80 percent of the water with cement, fly ash (if used) and aggregates.
- Add remaining water.
- Mix 30-40 revolutions at 12-15 RPM.
- Add high range water-reducing admixture.
- Mix 60-70 revolutions at 12-15 RPM.

(2) Stationary Mixer:

- The microsilica slurry shall be diluted into the water stream or weigh box prior to adding into mixer. Combine simultaneously air entraining admixture, water-reducing admixture and/or retarding admixture, microsilica slurry and 80 percent of the water with cement, fly ash (if used) and aggregates.
- Add remaining water.
- After mixing cycle is completed deposit into truck mixer.
- Add high range water-reducing admixture.
- Mix 60-70 revolutions at 12-15 RPM.

(b) Densified microsilica (bulk):

(1) Truck Mixer:

- Same as (a)1 above except the densified microsilica shall be added with the cement.

(2) Stationary Mixer:

- Same as (a)2 above except the densified microsilica shall be added with the cement.

(c) Densified microsilica (bag):

Bagged microsilica shall be kept dry. No bag or material containing moisture shall be introduced into the concrete mixer.

(1) Truck Mixer:

- Combine air entraining admixture, water-reducing admixture and/or retarding admixture and 80 percent of the water.
- Add cement, fly ash (if used), and aggregates.
- Add remaining water.

- Mix 30-40 revolutions at 12-15 RPM.
- Add microsilica.
- Mix 70-80 revolutions at 12-15 RPM.
- Add high range water-reducing admixture.
- Mix 60-70 revolutions at 12-15 RPM.

(2) Stationary Mixer:

- Combine air entraining admixture, water-reducing admixture and/or retarding admixture and 80% of the water.
- Add cement, fly ash (if used), and aggregates.
- Add remaining water.
- After mixing cycle is completed deposit into truck mixer.
- Add microsilica to truck.
- Mix 70-80 revolutions at 12-15 RPM.
- Add high range water-reducing admixture.
- Mix 60-70 revolutions at 12-15 RPM.

Note 7: Grout. The grout for bonding new concrete to old concrete shall be proportioned by weight (mass) and mixed at the job site, or it may be ready-mixed if agitated while at the job site. The bonding grout shall consist of one part portland cement and two parts sand, mixed with sufficient water to form a slurry. The bonding grout shall have a consistency allowing it to be scrubbed onto the prepared surface with a stiff brush or broom leaving a thin, uniform coating that will not run or puddle in low spots. Grout that cannot be easily and evenly applied or has lost its consistency may be rejected by the Engineer. Grout that is more than one hour old shall not be used.

At the option of the Contractor the grout may be applied by mechanical applicators. If this option is chosen, the sand shall be eliminated from the grout mix.

Equipment: The equipment used shall be subject to the approval of the Engineer and shall meet the following requirements:

(a) Surface Preparation Equipment. Surface preparation equipment shall be according to the applicable portions of Section 1100 and the following:

- (1) Sawing Equipment. Sawing equipment shall be a concrete saw capable of sawing concrete to the specified depth.
- (2) Mechanical Blast Cleaning Equipment. Mechanical blast cleaning may be performed by high-pressure waterblasting or shotblasting. Mechanical blast cleaning equipment shall be capable of removing weak concrete at the surface, including the microfractured concrete surface layer remaining as a result of mechanical scarification, and shall have oil traps.

Mechanical high-pressure waterblasting equipment shall be mounted on a wheeled carriage and shall include multiple nozzles mounted on a rotating assembly. The distance between the nozzles and the deck surface shall be kept constant and the wheels shall maintain contact with the deck surface during operation.

- (3) Hand-Held Blast Cleaning Equipment. Blast cleaning using hand-held equipment may be performed by high-pressure waterblasting or abrasive blasting. Hand-held blast cleaning equipment shall have oil traps.

Hand-held high-pressure waterblasting equipment that is used in areas inaccessible to mechanical blast cleaning equipment shall have a minimum pressure of 7,000 psi (48 MPa).

- (4) Mechanical Scarifying Equipment. Scarifying equipment shall be a power-operated, mechanical scarifier capable of uniformly scarifying or removing the old concrete surface and new patches to the depths required in a satisfactory manner. Other types of removal devices may be used if their operation is suitable and they can be demonstrated to the satisfaction of the Engineer.

- (5) Hydro-Scarification Equipment. The hydro-scarification equipment shall consist of filtering and pumping units operating with a computerized, self-propelled robotic machine with gauges and settings that can be easily verified. The equipment shall use potable water according to Section 1002. Operation of the equipment shall be performed and supervised by qualified personnel certified by the equipment manufacturer. Evidence of certification shall be presented to the Engineer. The equipment shall be capable of removing concrete to the specified depth and be capable of removing rust and old concrete particles from exposed reinforcement bars. The hydro-scarification equipment shall be calibrated before being used and shall operate at a uniform pressure sufficient to remove the specified depth of concrete in a timely manner.

- (6) Vacuum Cleanup Equipment. The equipment shall be equipped with fugitive dust control devices capable of removing wet debris and water all in the same pass. Vacuum equipment shall also be capable of washing the deck with pressurized water prior to the vacuum operation to dislodge all debris and slurry from the deck surface.

- (7) Power-Driven Hand Tools. Power-driven hand tools will be permitted including jackhammers lighter than the nominal 45 lb. (20 kg) class. Jackhammers or chipping hammers shall not be operated at an angle in excess of 45 degrees measured from the surface of the slab.

- (b) Pull-off Test Equipment. Equipment used to perform pull-off testing shall be either approved by the Engineer, or obtained from one of the following approved sources:

James Equipment
007 Bond Tester
800-426-6500

Germann Instruments, Inc.
BOND-TEST Pull-off System
847-329-9999

SDS Company
DYNA Pull-off Tester
805-238-3229

Pull-off test equipment shall include all miscellaneous equipment and materials to perform the test and clean the equipment, as indicated in the Illinois Test Procedures 304 and 305 "Pull-off Test (Surface or Overlay Method)".

Prior to the start of testing, the Contractor shall submit to the Engineer a technical data sheet and material safety data sheet for the epoxy used to perform the testing. For solvents used to clean the equipment, a material safety data sheet shall be submitted.

- (c) Concrete Equipment. Equipment for proportioning and mixing the concrete shall be according to Article 1020.03.
- (d) Finishing Equipment. Finishing equipment shall be according to Article 503.03.
- (e) Mechanical Fogging Equipment. Mechanical fogging equipment shall be according to 1103.17 (k)

Construction Requirements: Sidewalks, curbs, drains, reinforcement and/or existing transverse and longitudinal joints which are to remain in place shall be protected from damage during scarification and cleaning operations. All damage caused by the Contractor shall be corrected, at the Contractor's expense, to the satisfaction of the Engineer.

The Contractor shall control the runoff water generated by the various construction activities in such a manner as to minimize, to the maximum extent practicable, the discharge of construction debris into adjacent waters, and shall properly dispose of the solids generated according to Article 202.03. Runoff water will not be allowed to constitute a hazard on adjacent or underlying roadways, waterways, drainage areas or railroads nor be allowed to erode existing slopes.

(a) Deck Preparation:

- (1) Bridge Deck Scarification. The scarification work shall consist of removing the designated concrete deck surface using mechanical or hydro-scarifying equipment as specified. The areas designated shall be scarified uniformly to the depth as specified on the plans. In areas of the deck not accessible to the scarifying equipment, power-driven hand tools will be permitted. Power driven hand tools shall be used for removal around areas to remain in place.

A trial section on the existing deck surface will be designated by the Engineer to demonstrate that the equipment, personnel and methods of operation are capable of producing results satisfactory to the Engineer. The trial section will consist of approximately 30 sq. ft. (3 sq. m).

Once the settings for the equipment are established, they shall not be changed without the permission of the Engineer. The removal shall be verified, as necessary, at least every 16 ft. (5 m) along the cutting path. If sound concrete is being removed below the desired depth, the equipment shall be reset or recalibrated.

If the use of hydro-scarification equipment is specified, the Contractor may use mechanical scarification equipment to remove an initial depth of concrete provided that the last 1/4 in. (6 mm) of removal is accomplished with hydro-scarification equipment. If the Contractor's use of mechanical scarifying equipment results in exposing, snagging, or dislodging the top mat of reinforcing steel, the scarifying shall be stopped immediately and the remaining removal shall be accomplished using the hydro-scarification equipment.

All damage to the existing reinforcement resulting from the Contractor's operation shall be repaired or replaced at the Contractor's expense as directed by the Engineer. Replacement shall include the removal of any additional concrete required to position or splice the new reinforcing steel. Undercutting of exposed reinforcement bars shall only be as required to replace or repair damaged or corroded reinforcement. Repairs to existing reinforcement shall be according to the Special Provision for "Deck Slab Repair".

After hydro-scarification the deck shall be vacuum cleaned in a timely manner before the water and debris are allowed to dry and re-solidify to the deck. The uses of alternative cleaning and debris removal methods to minimize driving heavy vacuum equipment over exposed deck reinforcement may be used subject to the approval of the Engineer.

- (2) Deck Patching. After bridge deck scarification, all designated patching, except as note below, shall be completed according to the Special Provision for "Deck Slab Repair". All full depth patching shall be completed prior to final surface preparation. When mechanical scarification is specified, partial depth patches may be fill with overlay material at the time of overlay placement.

All patches placed prior to overlay placement shall be struck off and then roughened with a suitable stiff bristled broom or wire brush to provide a rough texture designed to promote bonding of the overlay. Hand finishing of the patch surface shall be kept to a minimum to prevent overworking of the surface.

After scarification, the deck shall be thoroughly cleaned of broken concrete and other debris. The Engineer will sound the scarified deck and all remaining unsound areas will be marked for additional removal and/or repairs as applicable. If the bottom mat of reinforcement is exposed, that area shall be defined as a full depth repair.

In areas where hydro-scarification is specified, No separate payment for partial depth patching will be made regardless of whether it was detailed in the plans or not. Just prior to performing hydro-scarification, the deck shall be sounded, with unsound areas marked on the deck to assist the hydro-scarification process in performing the partial depth removal simultaneously with the hydro-scarification operation. If in the opinion of the Engineer additional removal is required after the hydro-scarification process, which could not have been anticipated or accounted for by normal modifications to the scarification process (such as modifying the dwell time or Nozzle pressure), such removal shall be paid for according to Article 109.04. Any removal required or made below the specified depth for scarification of the bridge deck, which does not result in full depth patching, shall be filled with the overlay material at the time of the overlay placement.

- (3) Final Surface Preparation. Final surface preparation shall consist of the operation of mechanical blast cleaning equipment to remove any weak concrete at the surface, including the microfractured concrete surface layer remaining as a result of mechanical scarification. Any areas determined by the Engineer to be inaccessible to mechanical equipment shall be thoroughly blast cleaned with hand-held equipment.

When hydro-scarification equipment is used for concrete removal, the deck surface need not be blast cleaned with mechanical equipment unless the spoils from the scarification operation are allowed to dry and re-solidify on the deck surface.

Final surface preparation shall also include the cleaning of all dust, debris, and concrete fines from the deck surface including vertical faces of curbs, previously placed adjacent overlays, barrier walls up to a height of 1 in. (25 mm) above the overlay, depressions, and beneath reinforcement bars. Hand-held high-pressure waterblasting equipment shall be used for this operation.

If mechanical scarification is used to produce the final deck surface texture, surface pull-off testing will be required. After the final surface preparation has been completed and before placement of the overlay, the prepared deck surface will be tested by the Engineer according to the Illinois Test Procedure 304 "Pull-off Test (Surface Method)". The Contractor shall provide the test equipment.

- a. Start-up Testing. Prior to the first overlay placement, the Engineer will evaluate the blast cleaning method. The start-up area shall be a minimum of 600 sq. ft. (56 sq. m). After the area has been prepared, six random test locations will be determined by the Engineer, and tested according to the Illinois Test Procedure 304 "Pull-off Test (Surface Method)".

The average of the six tests shall be a minimum of 175 psi (1,207 kPa) and each individual test shall have a minimum strength of 160 psi (1,103 kPa). If the criteria are not met, the Contractor shall adjust the blast cleaning method. Start-up testing will be repeated until satisfactory results are attained.

Once an acceptable surface preparation method is established, it shall be continued for the balance of the work. The Contractor may, with the permission of the Engineer, change the surface preparation method, in which case, additional start-up testing will be required.

- b. Lot Testing. After start-up testing has been completed, the following testing frequency will be used. For each structure, each stage will be divided into lots of not more than 4500 sq. ft. (420 sq. m). Three random test locations will be determined by the Engineer for each lot, and tested according to the Illinois Test procedure 304 "Pull-off Test (Surface Method)".

The average of the three tests shall be a minimum of 175 psi (1,207 kPa) and each individual test shall have a minimum strength of 160 psi (1,103 kPa). In the case of a failing individual test or a failing average of three tests, the Engineer will determine the area that requires additional surface preparation by the Contractor. Additional test locations will be determined by the Engineer.

In addition to start-up and lot testing, the Department may require surface pull-off testing of areas inaccessible to mechanical blast cleaning equipment and blast cleaned with hand-held equipment. The Engineer shall determine each test location, and each individual test shall have a minimum strength of 175 psi (1,207 kPa).

Exposed reinforcement bars shall be free of dirt, detrimental scale, paint, oil, and other foreign substances which may reduce bond with the concrete. A tight non-scaling coating of rust is not considered objectionable. Loose, scaling rust shall be removed by rubbing with burlap, wire brushing, blast cleaning or other methods approved by the Engineer. All loose reinforcement bars, as determined by the Engineer, shall be retied at the Contractor's expense.

All dust, concrete fines, debris, including water, resulting from the surface preparation shall be confined and shall be immediately and thoroughly removed from all areas of accumulation. If concrete placement does not follow immediately after the final surface preparation, the area shall be carefully protected with well-anchored white polyethylene sheeting.

- (b) Pre-placement Procedure. Prior to placing the overlay, the Engineer will inspect the deck surface. All contaminated areas shall be blast cleaned again at the Contractor's expense.

Before placing the overlay, the finishing machine shall be operated over the full length of bridge segment to be overlaid to check support rails for deflection and confirm the minimum overlay thickness. All necessary adjustments shall be made and another check performed, unless otherwise directed by the Engineer.

- (c) Placement Procedure. Concrete placement shall be according to Article 503.07 and the following:

- (1) Bonding Methods. The Contractor shall prepare the deck prior to overlay placement by one of the following methods unless restricted as specified on the plans:

- a. Grout Method. The deck shall be cleaned to the satisfaction of the Engineer and shall be thoroughly wetted and maintained in a dampened condition for at least 12 hours before placement of the grout is started. Any excess water shall be removed by compressed air or by vacuuming prior to grout placement. Water shall not be applied to the deck surface within one hour before or at any time during placement of the grout. Immediately before placing the overlay mixture, the exposed area shall be thoroughly covered with a thin layer of grout. The grout shall be thoroughly scrubbed into the surface. All vertical as well as horizontal surfaces shall receive a thorough, even coating. The rate of grout placement shall be limited so the brushed grout does not dry out before it is covered with the concrete.

Grout that is allowed to become dry and chalky shall be blast cleaned and replaced at the Contractor's expense. No concrete shall be placed over dry grout.

- b. Direct Bond Method. The deck shall be cleaned to the satisfaction of the Engineer and shall be thoroughly wetted and maintained in a dampened condition for at least 12 hours before placement of the overlay. Any excess water shall be removed by compressed air or by vacuuming prior to beginning overlay placement. Water shall not be applied to the deck surface within one hour before or at any time during placement of the overlay.

- (2) Overlay Placement. Placement of the concrete shall be a continuous operation throughout the pour. The overlay shall be placed as close to its final position as possible and then mechanically consolidated and screeded to final grade. All fogging, finishing, and texturing shall be according to Article 503.16.

Internal vibration shall be performed along edges, adjacent to bulkheads, and where the overlay thickness exceeds 3 in. (75 mm). Internal vibration along the longitudinal edges of a pour shall be performed with a minimum of 2 hand-held vibrators, one on each edge of the pour. Hand finishing shall be performed along the edges of the pour and shall be done from sidewalks, curbs or work bridges.

A construction dam or bulkhead shall be installed in case of a delay of 30 minutes or more in the concrete placement operation.

All construction joints shall be formed. When required by the Engineer the previously placed overlay shall be sawed full-depth to a straight and vertical edge before fresh concrete is placed. The Engineer will determine the extent of the removal. When longitudinal joints are not shown on the plans, the locations shall be subject to approval by the Engineer and shall not be located in the wheel paths.

The Contractor shall stencil the date of construction (month and year) and the appropriate letters MS, or MSFA when fly ash is used in the mix design, into the overlay before it takes its final set. The stencil shall be located in a conspicuous location, as determined by the Engineer, for each stage of construction. This location shall be outside of the grooving where possible and within 3 ft. (1 m) of an abutment joint. The characters shall be 3 to 4 in. (75 mm to 100 mm) in height, 1/4 in. (5 mm) in depth and face the centerline of the roadway.

(3) Limitations of Operations:

- a. Weather limitations. Temperature control for concrete placement shall be according to 1020.14(b). The concrete protection from low air temperatures during the curing period shall be according to Article 1020.13(d). Concrete shall not be placed when rain is expected during the working period. If night placement is required, illumination and placement procedures will be subject to approval of the Engineer. No additional compensation will be allowed if night work is required.
- b. Other Limitations. Concrete delivery trucks shall be limited to a maximum load of 6 cu. yd. (4.6 cu. m).

Truck mixers, concrete pumps, or other heavy equipment will not be permitted on any portion of the deck where the top reinforcing mat has been exposed. Conveyors, buggy ramps and pump piping shall be installed in a way that will not displace undercut reinforcement bars. Air compressors may be operated on the deck only if located directly over a pier and supported off undercut reinforcement bars. Compressors will not be allowed to travel over undercut reinforcement bars.

Concrete removal may proceed during final cleaning and concrete placement on adjacent portions of the deck, provided the removal does not interfere in any way with the cleaning or placement operations.

If water or contaminants from the hydro-scarification flow into the area of final cleaning or concrete placement, hydro-scarification shall be suspended until the concrete has been placed and has cured a minimum of 24 hours. No concrete shall be removed within 6 ft. (1.8 m) of a newly-placed overlay until the concrete has obtained a minimum compressive strength of 3000 psi (20,700 kPa) or flexural strength of 600 psi (4,150 kPa).

- (4) Curing Procedure. The surface shall be continuously wet cured for at least 7 days according to Article 1020.13(a)(5) Wetted Cotton Mat Method.
- (5) Opening to Traffic. No traffic or construction equipment will be permitted on the overlay until after the specified cure period and the concrete has obtained a minimum compressive strength of 4000 psi (27,500 kPa) or flexural strength of 675 psi (4,650 kPa) unless permitted by the Engineer.
- (6) Overlay Testing. The Engineer reserves the right to conduct pull-off tests on the overlay to determine if any areas are not bonded to the underlying concrete, and at a time determined by the Engineer. The overlay will be tested according to the Illinois Test Procedure 305 "Pull-off Test (Overlay Method)", and the Contractor shall provide the test equipment. Each individual test shall have a minimum strength of 150 psi (1,034 kPa). Unacceptable test results will require removal and replacement of the overlay at the Contractor's expense, and the locations will be determined by the Engineer. When removing portions of an overlay, the saw cut shall be a minimum depth of 1 in. (25 mm).

If the overlay is to remain in place, all core holes due to testing shall be filled with a rapid set mortar or concrete. Only enough water to permit placement and consolidation by rodding shall be used, and the material shall be struck-off flush with the adjacent material.

For a rapid set mortar mixture, one part packaged rapid set cement shall be combined with two parts fine aggregate, by volume; or a packaged rapid set mortar shall be used. For a rapid set concrete mixture, a packaged rapid set mortar shall be combined with coarse aggregate according to the manufacturer's instructions; or a packaged rapid set concrete shall be used. Mixing of a rapid set mortar or concrete shall be according to the manufacturer's instructions.

Method of Measurement. The areas of mechanical and/or hydro scarification on the bridge deck will be measured for payment in square yards (square meters). No additional payment will be made for multiple passes of the equipment required to achieve the specified scarification depth.

The concrete overlay will be measured for payment in square yards (square meters).

When Bridge Deck Hydro-Scarification is specified, the additional concrete placed with the overlay, required to fill all depressions below the specified thickness will be measured for payment in cubic yards (cubic meters). The volume will be determined by subtracting the theoretical volume of the overlay from the ticketed volume of overlay delivered minus the volume estimated by the Engineer left in the last truck at the end of the overlay placement. The theoretical cubic yard (cubic meter) quantity for the overlay will be determined by multiplying the plan surface area of the overlay times the specified thickness of the overlay.

Basis of Payment. Concrete scarification of the bridge deck using mechanical scarification equipment will be paid for at the contract unit price per square yard (square meter) for CONCRETE BRIDGE DECK SCARIFICATION of the depth specified. Concrete scarification of the bridge deck using hydro-scarification equipment will be paid for at the contract unit price per square yard (square meter) for BRIDGE DECK HYDRO-SCARIFICATION of the depth specified.

Microsilica concrete overlay will be paid for at the contract unit price per square yard (square meter) for BRIDGE DECK MICROSILICA CONCRETE OVERLAY, of the thickness specified. When hydro-scarification equipment is used, the additional volume of overlay required to fill all depressions below the specified thickness will be paid for at the Contractor's actual material cost for the microsilica concrete per cubic yard (cubic meter) plus 15 percent.

When mechanical scarification equipment is used, additional partial depth patches poured monolithically with the overlay will be paid for at the contract unit price bid per square yard (square meter) for DECK SLAB REPAIR (PARTIAL).

When the Engineer conducts pull-off tests on the overlay and they are acceptable, Contractor expenses incurred due to testing and for filling core holes will be paid according to Article 109.04. Unacceptable pull-off tests will be at the Contractor's expense.

When specified, the Contractor has the option of choosing the type of overlay. The options will be limited to those specified in the plans and will be paid for at the contract unit price per square yard (square meter) for BRIDGE DECK CONCRETE OVERLAY OPTION, of the thickness specified.

Overlay material placed off the deck in abutment backwalls, and/or other locations will not be measured for payment but will be included in the pay item involved.

UNDERWATER STRUCTURE EXCAVATION PROTECTION

Effective: April 1, 1995

Revised: March 6, 2009

Description. This work shall include all labor, materials, and equipment necessary for the isolation and protection of any excavations, from flowing water, which may be needed for construction at the locations shown on the plans and as required by the Specifications. Other than to install and remove the excavation protection no work shall be performed in flowing water. The protection may consist of diverting the water for the excavation by the uses of timbers, sheet piling, non erodible barrier material or other structural elements adequate to protect and support the excavation. The protection need not be watertight. All concrete placement below the waterline shall be tremied underwater into forms according to Article 503.08 of the Standard Specifications.

Tremied concrete shall be placed to an elevation 1 ft. (300 mm) above the water level at the time of construction.

The Contractor's plan for the subject protection shall address the proposed construction sequence, including water diversion and/or dewatering methods, erosion and sediment control measures, sediment traps, disposal of excavated material, effluent water, along with best management practices to prevent reintroduction of excavated material into flowing water, etc. The plan shall be approved by the Engineer before excavation protection and construction may begin. Any system selected by the Contractor in which safe design and construction requires that loads and stresses be computed and the size and strength of parts determined by mathematical calculations based upon scientific principles and engineering data shall be prepared and sealed by an Illinois Licensed Structural Engineer. When the excavation protection is no longer required, it shall be removed according to the Contractor's plan unless otherwise specified by the Engineer. All materials removed will become the property of the Contractor.

Basis of Payment. Excavation protection for structures will be paid for at the contract unit price each, for UNDERWATER STRUCTURE EXCAVATION PROTECTION at the locations specified.

TEMPORARY SOIL RETENTION SYSTEM

Effective: December 30, 2002

Revised : May 11, 2009

Description. This work shall consist of designing, furnishing, installing, adjusting for stage construction when required and subsequent removal of the temporary soil retention system according to the dimensions and details shown on the plans and in the approved design submittal.

General. The temporary soil retention system shall be designed by the Contractor as a minimum, to retain the exposed surface area specified in the plans or as directed by the Engineer.

The design calculations and details for the temporary soil retention system proposed by the Contractor shall be submitted to the Engineer for approval. The calculations shall be prepared and sealed by an Illinois Licensed Structural Engineer. This approval will not relieve the Contractor of responsibility for the safety of the excavation. Approval shall be contingent upon acceptance by all involved utilities and/or railroads.

Construction. The Contractor shall verify locations of all underground utilities before installing any of the soil retention system components or commencing any excavation. Any disturbance or damage to existing structures, utilities or other property, caused by the Contractor's operation, shall be repaired by the Contractor in a manner satisfactory to the Engineer at no additional cost to the Department. The soil retention system shall be installed according to the Contractor's approved design, or as directed by the Engineer, prior to commencing any related excavation. If unable to install the temporary soil retention system as specified in the approved design, the Contractor shall have the adequacy of the design re-evaluated. Any reevaluation shall be submitted to the Engineer for approval prior to commencing the excavation adjacent to the area in question. The Contractor shall not excavate below the maximum excavation line shown in the approved design without the prior permission of the Engineer. The temporary soil retention system shall remain in place until the Engineer determines it is no longer required.

The temporary soil retention system shall be removed and disposed of by the Contractor when directed by the Engineer. When allowed, the Contractor may elect to cut off a portion of the temporary soil retention system leaving the remainder in place. The remaining temporary soil retention system shall be removed to a depth which will not interfere with the new construction, and as a minimum, to a depth of 12 in. (300 mm) below the finished grade, or as directed by the Engineer. Removed system components shall become the property of the Contractor.

When an obstruction is encountered, the Contractor shall notify the Engineer and upon concurrence of the Engineer, the Contractor shall begin working to break up, push aside, or remove the obstruction. An obstruction shall be defined as any object (such as but not limited to, boulders, logs, old foundations etc.) where its presence was not obvious or specifically noted on the plans prior to bidding, that cannot be driven or installed through or around, with normal driving or installation procedures, but requires additional excavation or other procedures to remove or miss the obstruction.

Method of Measurement. The temporary soil retention system furnished and installed according to the Contractor's approved design or as directed by the Engineer will be measured for payment in place, in square feet (square meters). The area measured shall be the vertical exposed surface area envelope of the excavation supported by temporary soil retention system. Portions of the temporary soil retention system left in place for reuse in later stages of construction shall only be measured for payment once.

Any temporary soil retention system installed beyond those dimensions shown on the contract plans or the approved contractor's design without the written permission of the Engineer, shall not be measured for payment but shall be done at the contractor's own expense.

Basis of Payment. This work will be paid for at the contract unit price per square foot (square meter) for TEMPORARY SOIL RETENTION SYSTEM.

Payment for any excavation, related solely to the installation and removal of the temporary soil retention system and/or its components, shall not be paid for separately but shall be included in the unit bid price for TEMPORARY SOIL RETENTION SYSTEM. Other excavation, performed in conjunction with this work, will not be included in this item but shall be paid for as specified elsewhere in this contract.

Obstruction mitigation shall be paid for according to Article 109.04 of the Standard Specifications.

PIPE UNDERDRAINS FOR STRUCTURES

Effective: May 17, 2000

Revised: January 22, 2010

Description. This work shall consist of furnishing and installing a pipe underdrain system as shown on the plans, as specified herein, and as directed by the Engineer.

Materials. Materials shall meet the requirements as set forth below:

The perforated pipe underdrain shall be according to Article 601.02 of the Standard Specifications. Outlet pipes or pipes connecting to a separate storm sewer system shall not be perforated.

The drainage aggregate shall be a combination of one or more of the following gradations, FA1, FA2, CA5, CA7, CA8, CA11, or CA13 thru 16, according to Sections 1003 and 1004 of the Standard Specifications.

The fabric surrounding the drainage aggregate shall be Geotechnical Fabric for French Drains according to Article 1080.05 of the Standard Specifications.

Construction Requirements. All work shall be according to the applicable requirements of Section 601 of the Standard Specifications except as modified below.

The pipe underdrains shall consist of a perforated pipe drain situated at the bottom of an area of drainage aggregate wrapped completely in geotechnical fabric and shall be installed to the lines and gradients as shown on the plans.

Method of Measurement. Pipe Underdrains for Structures shall be measured for payment in feet (meters), in place. Measurement shall be along the centerline of the pipe underdrains. All connectors, outlet pipes, elbows, and all other miscellaneous items shall be included in the measurement. Concrete headwalls shall be included in the cost of Pipe Underdrains for Structures, but shall not be included in the measurement for payment.

Basis of Payment. This work will be paid for at the contract unit price per foot (meter) for PIPE UNDERDRAINS FOR STRUCTURES of the diameter specified. Furnishing and installation of the drainage aggregate, geotechnical fabric, forming holes in structural elements and any excavation required, will not be paid for separately, but shall be included in the cost of the pipe underdrains for structures.

POROUS GRANULAR EMBANKMENT, SPECIAL

Effective: September 28, 2005

Revised: November 14, 2008

Description. This work shall consist of furnishing and placing porous granular embankment special material as detailed on the plans, according to Section 207 except as modified herein.

Materials. The gradation of the porous granular material may be any of the following CA 8 thru CA 18, FA 1 thru FA 4, FA 7 thru FA 9, and FA 20 according to Articles 1003 and 1004.

Construction. The porous granular embankment special shall be installed according to Section 207, except that it shall be uncompacted.

Basis of Payment. This work will be paid for at the contract unit price per Cubic Yard (Cubic Meter) for POROUS GRANULAR EMBANKMENT, SPECIAL.

STRUCTURAL REPAIR OF CONCRETE

Effective: March 15, 2006

Revised: January 22, 2010

Description. This work shall consist of structurally repairing concrete.

Materials. Materials shall be according to the following.

Item	Article/Section
(a) Portland Cement Concrete (Note 1)	1020
(b) R1 or R2 Mortar (Note2)	
(c) Normal Weight Concrete (Note 3)	
(d) Shotcrete (High Performance) (Note 4)	
(e) Reinforcement Bars	1006.10
(f) Anchor Bolts	1006.09
(g) Water	1002
(h) Curing Compound (Type I)	1022
(i) Cotton Mats	1022.02
(j) Protective Coat	1023.01
(k) Epoxy (Note 5)	1025
(l) Mechanical Bar Splicers (Note 6)	

Note 1. The concrete shall be Class SI, except the cement factor shall be a minimum 6.65 cwt/cu. yd. (395 kg/cu. m), the coarse aggregate shall be a CA 16, and the strength shall be a minimum 4000 psi (27,500 kPa) compressive or 675 psi (4650 kPa) flexural at 14 days. A high range water-reducing admixture shall be used to obtain a 5-7 in. (125-175 mm) slump, but the cement factor shall not be reduced. This cement factor restriction shall also apply if a water-reducing admixture is used.

Note 2. The R1 or R2 mortar shall be from the Department's approved list of Packaged, Dry, Rapid Hardening, Cementitious Materials for Concrete Repairs with coarse aggregate added. The amount of coarse aggregate added to the R1 or R2 Mortar shall be per the manufacturer's recommendations. The coarse aggregate gradation shall be CA 16 from an Aggregate Gradation Control System source or a packaged aggregate meeting Article 1004.02 with a maximum size of 1/2 in. (12.5 mm). The R1 or R2 Mortar and coarse aggregate mixture shall comply with the air content and strength requirements for Class SI concrete as indicated in Note 1. Mixing shall be per the manufacturer's recommendations, except the water/cement ratio shall not exceed the value specified for Class SI concrete as indicated in Note 1. A high range water-reducing admixture shall be used to obtain a 5-7 in. (125-175 mm) slump.

Note 3. The packaged concrete mixture shall be from the Department's approved list of Packaged, Dry, Formed, Concrete Repair Mixtures. The materials and preparation of aggregate shall be according to ASTM C 387. Proportioning shall be according to ASTM C 387, except the minimum cement factor shall be 6.65 cwt/cu. yd. (395 kg/cu. m). Cement replacement with fly ash or ground granulated blast-furnace slag shall be according to Section 1020. The coarse aggregate shall be a maximum size of 1/2 in. (12.5 mm). The packaged concrete mixture shall comply with the air content and strength requirements for Class SI concrete as indicated in Note 1. Mixing shall be per the manufacturer's recommendations, except the water/cement ratio shall not exceed the value specified for Class SI concrete as indicated in Note 1. A high range water-reducing admixture shall be used to obtain a 5-7 in. (125-175 mm) slump.

Note 4. A packaged, pre-blended, and dry combination of materials, for the wet-mix shotcrete method shall be provided according to ASTM C 1480. An accelerator is prohibited, except the shotcrete may be modified at the nozzle with a non-chloride accelerator for overhead applications. The shotcrete shall be Type FA or CA, Grade FR, and Class I. The fibers shall be Type III synthetic according to ASTM C 1116.

The packaged shotcrete shall have a maximum water soluble chloride ion content of 0.06 % by weight (mass) of cement. The test shall be performed according to ASTM C 1218, and the hardened shotcrete shall have an age of 28 to 42 days at the time of test. The test shall be performed a minimum of once every two years.

Each individual aggregate used in the packaged shotcrete shall have either a maximum ASTM C 1260 expansion of 0.16 percent or a maximum ASTM C 1293 expansion of 0.040 percent. However, the ASTM C 1260 value may be increased to 0.27 percent for each individual aggregate if the cement total equivalent alkali content ($\text{Na}_2\text{O} + 0.658\text{K}_2\text{O}$) does not exceed 0.60 percent. As an alternative to these requirements, ASTM C 1567 testing which shows the packaged shotcrete has a maximum expansion of 0.16 percent may be submitted. The ASTM C 1260, C 1293, or C 1567 test shall be performed a minimum of once every two years.

The 7 and 28 day compressive strength requirements in ASTM C 1480 shall not apply. Instead the shotcrete shall obtain a minimum compressive strength of 4000 psi (27,500 kPa) at 14 days.

The packaged shotcrete shall be limited to the following proportions:

The portland cement and finely divided minerals shall be 6.05 cwt/cu. yd. (360 kg/cu. m) to 8.50 cwt/cu. yd. (505 kg/cu. m) for Type FA and 6.05 cwt/cu. yd. (360 kg/cu. m) to 7.50 cwt/cu. yd. (445 kg/cu. m) for Type CA. The portland cement shall not be below 4.70 cwt/cu. yd. (279 kg/cu. m) for Type FA or CA.

The finely divided mineral(s) shall constitute a maximum of 35 percent of the total cement plus finely divided mineral(s).

Class F fly ash is optional and the maximum shall be 20 percent by weight (mass) of cement.

Class C fly ash is optional and the maximum shall be 25 percent by weight (mass) of cement.

Ground granulated blast-furnace slag is optional and the maximum shall be 30 percent by weight (mass) of cement.

Microsilica is required and shall be a minimum of 5 percent by weight (mass) of cement, and a maximum of 10 percent. As an alternative to microsilica, high-reactivity metakaolin may be used at a minimum of 5 percent by weight (mass) of cement, and a maximum of 10 percent.

Fly ash shall not be used in combination with ground granulated blast-furnace slag. Class F fly ash shall not be used in combination with Class C fly ash. Microsilica shall not be used in combination with high-reactivity metakaolin. A finely divided mineral shall not be used in combination with a blended hydraulic cement, except for microsilica or high-reactivity metakaolin.

The water/cement ratio as defined in Article 1020.06 shall be a maximum of 0.42.

The air content as shot shall be 4.0 – 8.0 percent.

Note 5. In addition ASTM C 881, Type IV, Grade 2 or 3, Class A, B, or C may be used.

Note 6. Mechanical bar splicers shall be from the approved list of Mechanical Reinforcing Bar Splicers / Coupler Systems, and shall be capable of developing in tension at least 125 percent of the yield strength of the existing reinforcement bar.

Equipment. Equipment shall be according to Article 503.03 and the following.

Chipping Hammer – The chipping hammer for removing concrete shall be a light-duty pneumatic or electric tool with a 15 lb. (7 kg) maximum class or less.

Blast Cleaning Equipment – Blast cleaning equipment for concrete surface preparation shall be the abrasive type, and the equipment shall have oil traps.

Hydrodemolition Equipment – Hydrodemolition equipment for removing concrete shall be calibrated, and shall use water according to Section 1002.

High Performance Shotcrete Equipment – The batching, mixing, pumping, hose, nozzle, and auxiliary equipment shall be for the wet-mix shotcrete method, and shall meet the requirements of ACI 506R.

Construction Requirements

General. The repair methods shall be either formed concrete repair or shotcrete. The repair method shall be selected by the Contractor with the following rules.

- (a) Rule 1. For formed concrete repair, a subsequent patch to repair the placement point after initial concrete placement will not be allowed. As an example, this may occur in a vertical location located at the top of the repair.
- (b) Rule 2. Formed concrete repair shall not be used for overhead applications.
- (c) Rule 3. Shotcrete shall not be used for column repairs greater than 4 in. (100 mm) in depth, or any repair location greater than 8 in. (205 mm) in depth. The only exception to this rule would be for a horizontal application, where the shotcrete may be placed from above in one lift.
- (d) Rule 4. If formed concrete repair is used for locations that have reinforcement with less than 0.75 in. (19 mm) of concrete cover, the concrete mixture shall contain fly ash or ground granulated blast-furnace slag at the maximum cement replacement allowed.

Temporary Shoring or Cribbing. When a temporary shoring or cribbing support system is required, the Contractor shall provide details and computations, prepared and sealed by an Illinois licensed Structural Engineer, to the Department for review and approval. When ever possible the support system shall be installed prior to starting the associated concrete removal. If no system is specified, but during the course of removal the need for temporary shoring or cribbing becomes apparent or is directed by the Engineer due to a structural concern, the Contractor shall not proceed with any further removal work until an appropriate and approved support system is installed.

Concrete Removal. The Contractor shall provide ladders or other appropriate equipment for the Engineer to mark the removal areas. Repair configurations will be kept simple, and squared corners will be preferred. The repair perimeter shall be sawed a depth of 1/2 in. (13 mm) or less, as required to avoid cutting the reinforcement. Any cut reinforcement shall be repaired or replaced at the expense of the Contractor. If the concrete is broken or removed beyond the limits of the initial saw cut, the new repair perimeter shall be recut. The areas to be repaired shall have all loose, unsound concrete removed completely by the use of chipping hammers, hydrodemolition equipment, or other methods approved by the Engineer. The concrete removal shall extend along the reinforcement bar until the reinforcement is free of bond inhibiting corrosion. The outermost layer of reinforcement bar within the repair area shall be undercut to a depth of 3/4 in. (19 mm) or the diameter of the reinforcement bar, whichever value is larger. The underlying transverse reinforcement bar shall also be undercut as previously described, unless the reinforcement is not corroded, and the reinforcement bar is encased and well bonded to the surrounding concrete.

If sound concrete is encountered before existing reinforcement bars are exposed, further removal of concrete shall not be performed unless the minimum repair depth is not met.

The repair depth shall be a minimum of 1 in. (25 mm). The substrate profile shall be $\pm 1/16$ in. (± 1.5 mm). The perimeter of the repair area shall have a vertical face.

If a repair is located at the ground line, any excavation required below the ground line to complete the repair shall be included in this work.

The Contractor shall have a maximum of 14 calendar days to complete each repair location with concrete or shotcrete, once concrete removal has started for the repair.

The Engineer shall be notified of concrete removal that exceeds 6 in. (150 mm) in depth, one fourth the cross section of a structural member, more than half the vertical column reinforcement is exposed in a cross section, more than 6 consecutive reinforcement bars are exposed in any direction, within 1.5 in. (38 mm) of a bearing area, or other structural concern. Excessive deterioration or removal may require further evaluation of the structure or installation of temporary shoring and cribbing support system.

Surface Preparation. Prior to placing the concrete or shotcrete, the Contractor shall prepare the repair area and exposed reinforcement by blast cleaning. The blast cleaning shall provide a surface that is free of oil, dirt, and loose material.

If a succeeding layer of shotcrete is to be applied, the initial shotcrete surface and remaining exposed reinforcement shall be free of curing compound, oil, dirt, loose material, rebound (i.e. shotcrete material leaner than the original mixture which ricochets off the receiving surface), and overspray.

Preparation may be by lightly brushing or blast cleaning if the previous shotcrete surface is less than 36 hours old. If more than 36 hours old, the surface shall be prepared by blast cleaning.

The repair area and perimeter vertical face shall have a rough surface. Care shall be taken to ensure the perimeter sawcut is roughened. Just prior to concrete or shotcrete placement, saturate the repair area with water to a saturated surface-dry condition. Any standing water shall be removed.

Concrete or shotcrete placement shall be done within 3 calendar days of the surface preparation or the repair area shall be prepared again.

Reinforcement. Exposed reinforcement bars shall be cleaned of concrete and corrosion by blast cleaning. After cleaning, all exposed reinforcement shall be carefully evaluated to determine if replacement or additional reinforcement bars are required.

Reinforcing bars that have been cut or have lost 25 percent or more of their original cross sectional area shall be supplemented by new in kind reinforcement bars. New bars shall be lapped a minimum of 32 bar diameters to existing bars. A mechanical bar splicer shall be used when it is not feasible to provide the minimum bar lap. No welding of bars shall be performed.

Intersecting reinforcement bars shall be tightly secured to each other using 0.006 in. (1.6 mm) or heavier gauge tie wire, and shall be adequately supported to minimize movement during concrete placement or application of shotcrete.

For reinforcement bar locations with less than 0.75 in. (19 mm) of cover, protective coat shall be applied to the completed repair. The application of the protective coat shall be according to Article 503.19, 2nd paragraph, except blast cleaning shall be performed to remove curing compound.

The Contractor shall anchor the new concrete to the existing concrete with 3/4 in. (19 mm) diameter hook bolts for all repair areas where the depth of concrete removal is greater than 8 in. (205 mm) and there is no existing reinforcement extending into the repair area. The hook bolts shall be spaced at 15 in. (380 mm) maximum centers both vertically and horizontally, and shall be a minimum of 12 in. (305 mm) away from the perimeter of the repair. The hook bolts shall be installed according to Section 584.

Repair Methods. All repair areas shall be inspected and approved by the Engineer prior to placement of the concrete or application of the shotcrete.

- (a) Formed Concrete Repair. Falsework shall be according to Article 503.05. Forms shall be according to Article 503.06. Formwork shall provide a smooth and uniform concrete finish, and shall approximately match the existing concrete structure. Formwork shall be mortar tight and closely fitted where they adjoin the existing concrete surface to prevent leakage. Air vents may be provided to reduce voids and improve surface appearance. The Contractor may use exterior mechanical vibration, as approved by the Engineer, to release air pockets that may be entrapped.

The concrete for formed concrete repair shall be a Class SI Concrete, or a packaged R1 or R2 Mortar with coarse aggregate added, or a packaged Normal Weight Concrete at the Contractor's option.

The concrete shall be placed and consolidated according to Article 503.07. The concrete shall not be placed when frost is present on the surface of the repair area, or the surface temperature of the repair area is less than 40 °F (4 °C). All repaired members shall be restored as close as practicable to their original dimensions.

Curing shall be done according to Article 1020.13.

If temperatures below 45°F (7°C) are forecast during the curing period, protection methods shall be used. Protection Method I according to Article 1020.13(d)(1), or Protection Method II according to Article 1020.13(d)(2) shall be used during the curing period.

The surfaces of the completed repair shall be finished according to Article 503.15.

- (b) Shotcrete. Shotcrete shall be tested by the Engineer for air content according to Illinois Modified AASHTO T 152. Obtain the sample in a damp, non-absorbent container from the discharge end of the nozzle.

For compressive strength of shotcrete, a 18 x 18 x 3.5 in. (457 x 457 x 89 mm) test panel shall be shot by the Contractor for testing by the Engineer. A steel form test panel shall have a minimum thickness of 3/16 in. (5 mm) for the bottom and sides. A wood form test panel shall have a minimum 3/4 in. (19 mm) thick bottom, and a minimum 1.5 in. (38 mm) thickness for the sides. The test panel shall be cured according to Article 1020.13 (a) (3) or (5) while stored at the jobsite and during delivery to the laboratory. After delivery to the laboratory for testing, curing and testing shall be according to ASTM C 1140.

The method of alignment control (i.e. ground wires, guide strips, depth gages, depth probes, and formwork) to ensure the specified shotcrete thickness and reinforcing bar cover is obtained shall be according to ACI 506R. Ground wires shall be removed after completion of cutting operations. Guide strips and formwork shall be of dimensions and a configuration that do not prevent proper application of shotcrete. Metal depth gauges shall be cut 1/4 in. (6 mm) below the finished surface. All repaired members shall be restored as close as practicable to their original dimensions.

For air temperature limits when applying shotcrete in cold weather, the first paragraph of Article 1020.14(b) shall apply. For hot weather, shotcrete shall not be applied when the air temperature is greater than 90°F (32°C). The applied shotcrete shall have a minimum temperature of 50°F (10°C) and a maximum temperature of 90°F (32°C). The shotcrete shall not be applied during periods of rain unless protective covers or enclosures are installed. The shotcrete shall not be applied when frost is present on the surface of the repair area, or the surface temperature of the repair area is less than 40°F (4°C). If necessary, lighting shall be provided to provide a clear view of the shooting area.

The shotcrete shall be applied according to ACI 506R, and shall be done in a manner that does not result in cold joints, laminations, sandy areas, voids, sags, or separations. In addition, the shotcrete shall be applied in a manner that results in maximum densification of the shotcrete.

Shotcrete which is identified as being unacceptable while still plastic shall be removed and re-applied.

The nozzle shall normally be at a distance of 2 to 5 ft. (0.6 to 1.5 m) from the receiving surface, and shall be oriented at right angles to the receiving surface. Exceptions to this requirement will be permitted to fill corners, encase large diameter reinforcing bars, or as approved by the Engineer. For any exception, the nozzle shall never be oriented more than 45 degrees from the surface. Care shall be taken to keep the front face of the reinforcement bar clean during shooting operations. Shotcrete shall be built up from behind the reinforcement bar. Accumulations of rebound and overspray shall be continuously removed prior to application of new shotcrete. Rebound material shall not be incorporated in the work.

Whenever possible, shotcrete shall be applied to the full thickness in a single layer. The maximum thickness shall be 4 in. (100 mm) unless the shotcrete is applied from above on a horizontal surface, or a thicker application is approved by the Engineer. When two or more layers are required, the minimum number shall be used and shall be done in a manner without sagging or separation. A flash coat (i.e. a thin layer of up to 1/4 in. (6 mm) applied shotcrete) may be used as the final lift for overhead applications.

Prior to application of a succeeding layer of shotcrete, the initial layer of shotcrete shall be prepared according to the surface preparation and reinforcement bar cleaning requirements. Upon completion of the surface preparation and reinforcement bar treatment, water shall be applied according to the surface preparation requirements unless the surface is moist. The second layer of shotcrete shall then be applied within 30 minutes.

Shotcrete shall be cut back to line and grade using trowels, cutting rods, screeds or other suitable devices. The shotcrete shall be allowed to stiffen sufficiently before cutting. Cutting shall not cause cracks or delaminations in the shotcrete. For depressions, cut material may be used for small areas. Rebound material shall not be incorporated in the work. For the final finish, a wood float shall be used to approximately match the existing concrete texture. All repaired members shall be restored as close as practicable to their original dimensions.

Contractor operations for curing shall be continuous with shotcrete placement and finishing operations. The Engineer may require modification of operations to ensure satisfactory results are obtained. Cotton mats shall be applied according to Article 1020.13(a)(5) except the exposed layer of shotcrete shall be covered within 10 minutes after finishing, and wet curing shall begin immediately. As an alternative to this method, Type I curing compound shall be applied according to Article 1020.13(a)(4) within 10 minutes and moist curing with cotton mats shall begin within 3 hours. For overhead applications where the final shotcrete layer has been applied, the Contractor has the option to use Type I curing compound in lieu of the cotton mats. Note 5 of the Index Table in Article 1020.13 shall apply to the membrane curing method. The curing compound shall be applied according to Article 1020.13(a)(4).

When a shotcrete layer is to be covered by a succeeding shotcrete layer within 36 hours, the repair area shall be protected with intermittent hand fogging, or wet curing with either burlap or cotton mats shall begin within 10 minutes.

Intermittent hand fogging may be used only for the first hour. Thereafter, wet curing with burlap or cotton mats shall be used until the succeeding shotcrete layer is applied. Intermittent hand fogging may be extended to the first hour and a half if the succeeding shotcrete layer is applied by the end of this time.

The curing period shall be for 7 days, except when there is a succeeding layer of shotcrete. In this instance, the initial shotcrete layer shall be cured until the surface preparation and reinforcement bar treatment is started.

If temperatures below 45°F (7°C) are forecast during the curing period, protection methods shall be used. Protection Method I according to Article 1020.13(d)(1), or Protection Method II according to Article 1020.13(d)(2) shall be used during the curing period

Inspection of Completed Work. The Contractor shall provide ladders or other appropriate equipment for the Engineer to inspect the repaired areas. After curing but no sooner than 28 days after placement of concrete or shooting of shotcrete, the repair shall be examined for conformance with original dimensions, cracks, voids, and delaminations. Sounding for delaminations will be done with a hammer or by other methods determined by the Engineer.

The repaired area shall be removed and replaced, as determined by the Engineer, for nonconformance with original dimensions, surface cracks greater than 0.01 in. (0.25 mm) in width, map cracking with a crack spacing in any direction of 18 in. (0.45 m) or less, voids, or delaminations.

If a nonconforming repair is allowed to remain in place, cracks 0.01 in. (0.25 mm) or less shall be repaired with epoxy according to Section 590. For cracks less than 0.007 in. (2 mm), the epoxy may be applied to the surface of the crack. Voids shall be repaired according to Article 503.15.

Publications and Personnel Requirements. The Contractor shall provide a current copy of ACI 506R to the Engineer a minimum of one week prior to start of construction.

The shotcrete personnel who perform the work shall have current American Concrete Institute (ACI) nozzle men certification for vertical wet and overhead wet applications, except one individual may be in training. This individual shall be adequately supervised by a certified ACI nozzle men as determined by the Engineer. A copy of the nozzle men certificate(s) shall be given to the Engineer.

Method of Measurement. This work will be measured for payment in place and the area computed in square feet (square meters). For a repair at a corner, both sides will be measured.

Basis of Payment. This work will be paid for at the contract unit price per square foot (square meter) for STRUCTURAL REPAIR OF CONCRETE (DEPTH GREATER THAN 5 IN. (125 MM), STRUCTURAL REPAIR OF CONCRETE (DEPTH EQUAL TO OR LESS THAN 5 IN. (125 MM).

When not specified to be paid for elsewhere, the work to design, install, and remove the temporary shoring and cribbing will be paid for according to Article 109.04.

With the exception of reinforcement damaged by the Contractor during removal, the furnishing and installation of supplemental reinforcement bars, mechanical bar splicers, hook bolts, and protective coat will be paid according to Article 109.04.

MECHANICAL SPLICERS

Effective: September 21, 1995

Revised: May 11, 2009

Description. This work shall consist of furnishing and installing mechanical splices according to the plans and this special provision.

Materials and Procedures. The mechanical connection may be made by means of an approved mechanical splicer. Splicer bar type systems lapped with the primary reinforcement will not be allowed. The mechanical splicer shall develop in tension at least 125 percent of the specified yield strength of the bar.

When both reinforcement bars being spliced are epoxy coated the mechanical splicer shall also be epoxy coated according to AASHTO M284.

Contact the Bureau of Materials for a current list of approved mechanical reinforcing bar splicers/coupler systems.

Installation. The Contractor shall supply the manufacturer's written installation instructions to the Engineer prior to installing the mechanical splices.

Testing. A minimum of two tension tests will be made with the method of splicing selected on each size bar to be spliced. The Contractor shall furnish certified copies of the test reports from an independent testing laboratory.

Basis of Payment. This work will be paid for at the contract unit price each for MECHANICAL SPLICERS.

DIAMOND GRINDING AND SURFACE TESTING BRIDGE SECTIONS

Effective: December 6, 2004

Revised: July 9, 2008

Description. This work shall consist of diamond grinding and surface testing bridge sections.

A bridge section shall consist of the bridge deck plus the bridge approach pavement and connector pavement on each side of the bridge.

Equipment. Equipment shall be according to the following.

- (a) Diamond Grinder. The diamond grinder shall be a self-propelled planing machine specifically designed for diamond saw grinding. It shall be capable of accurately and automatically establishing the profile grade and shall have a positive means for controlling cross slope. It shall also have an effective means for removing excess material and slurry from the surface and for preventing dust from escaping into the air. The diamond grinder shall not cause strain or damage to the surface.

The grinding head shall be a minimum of 4 ft. (1.2 m) wide and the diamond saw blades shall be gang mounted on the grinding head at a rate of 50 blades / ft. (164 blades/m).

(b) Surface Testing Equipment. Required surface testing and analysis equipment and their jobsite transportation shall be provided by the Contractor.

(1) Profile Testing Device. The Profile Testing Device shall have a decal displayed to indicate it has been tested through the PEV Program administered by the Department.

a. California Profilograph. The California Profilograph shall be either computerized or manual and have a frame 25 ft (8 m) in length supported upon multiple wheels at either end. The profile shall be recorded from the vertical movement of a wheel attached to the frame at mid point.

The California Profilograph shall be calibrated according to the manufacturer's recommendations and California Test 526. All calibration traces and calculations shall be submitted to the Engineer for the project file.

b. Inertial Profiler. The inertial profiler shall be either an independent device or a system that can be attached to another vehicle using one or two non-contact sensors to measure the pavement profile. The inertial profiler shall be capable of performing a simulation of the California Profilograph to provide results in the Profile Index format.

The inertial profiler shall be calibrated according to the manufacturer's recommendations. All calibration traces and calculations shall be submitted to the Engineer for the project file.

(3) Trace Analysis. The Contractor shall reduce/evaluate these traces using a 0.00 in. (0.0 mm) blanking band and determine a Profile Index in in./mile (mm/km) for each bridge section. Traces produced using a computerized profile testing device will be evaluated without further reduction. When using a manual profile testing device, the Contractor shall provide an electronic scanner, a computer, and software to reduce the trace. All analysis equipment (electronic scanner, computerized recorder, etc.) shall be able to accept 0.00 in. (0.0 mm) for the blanking band.

All traces from bridge sections tested with the profile testing device shall be recorded on paper with scales of 300:1 longitudinally and 1:1 vertically. Equipment and software settings of the profile testing device and analysis equipment shall be set to those values approved through the PEV Program."

CONSTRUCTION REQUIREMENTS

General. After all components have been properly cured, the bridge section shall be ground over its entire length and over a width that extends to within 2 ft. (600 mm) of the curbs or parapets. The maximum thickness removed shall be 1/4 in. (6 mm); however, when the bridge deck thickness noted on the plans can be maintained, as a minimum, additional removal thickness may be permitted.

The vertical difference between longitudinal passes shall be 1/8 in. (3 mm) maximum. The grinding at the ends of the bridge section shall be diminished uniformly at a rate of 1:240 over the connector pavements.

Grinding shall be continuous through all joints. When sealed joints are specified, grinding shall be completed prior to final installation of the joints seals. During grinding, joint openings shall be temporarily filled with material approved by the Engineer.

Surface Testing. The diamond ground bridge section shall be surface tested in the presence of the Engineer prior to opening to traffic. All objects and debris shall be removed from the surface prior to testing. During surface testing, joint openings may be temporarily filled with material approved by the Engineer.

Profiles shall be taken in the wheel paths of each lane, 3 ft. (1 m) from and parallel to the planned lane lines. A guide shall be used to maintain the required distance.

The profile trace shall be printed on continuous paper with scales of 300:1 horizontally and 1:1 vertically and shall have stationing indicated every 500 ft. (150 m) at a minimum. Both ends of the profile trace shall be labeled with the following information: contract number, beginning and ending stationing, which direction is up on the trace, which direction the profilograph was pushed, and profilograph operator name(s). The top portion of the Profilograph Report of Bridge Smoothness (Attachment 1) shall be completed and the form secured around the trace roll.

Trace Reduction and Bump Locating Procedure. All traces shall be reduced. Traces produced by a mechanical recorder shall be reduced using an electronic scanner and computer software. This software shall calculate the profile index and indicate any bumps in excess of 0.30 in. (8 mm) with a line intersecting the profile on the printout. Computerized recorders shall provide the same information.

The average profile index and locations with deviations exceeding the 0.30 in. (8 mm) limit shall be recorded on the Profilograph Report of Bridge Smoothness as shown in Attachment 1.

All traces and completed reports shall be provided within two working days of completing the testing to the Engineer for the project file. Traces from either a computerized profile testing device or analysis software used with a manual profile testing device shall display the settings used for the data reduction. The Engineer will compare these settings with the approved settings from the PEV Program. If the settings do not match, the results will be rejected and the section shall be retested/reanalyzed with the appropriate settings.

Corrective Actions. Within the bridge section, all deviations in excess of 0.30 in. (8 mm) in a length of 25 ft. (8 m) or less shall be corrected regardless of the profile index value. Correction of deviations shall not result in the deck thickness being less than the minimum.

Any bridge section having an average profile index greater than 35.0 in./mile (555 mm), including bumps, shall be corrected to reduce the profile index to 35.0 in./mile (555 mm/km) or less on each trace.

Where corrective work is performed, the bridge section shall be retested to verify that corrections have produced a profile index of 35.0 in./mile (555 mm/km) or less for each trace.

Corrective actions shall be performed at no additional cost to the department. The Contractor shall furnish the surface profilograph tracing and the completed form to the Engineer within two working days after any corrections are made.

The Engineer may perform profilograph testing on the surface at any time for monitoring and comparison purposes.

Smoothness Assessments. Smoothness assessments will be based on the final average profile index determined for the bridge section after performing any corrective work. Additional payments/deductions will be as indicated in the Smoothness Assessment Schedule.

The Smoothness Assessment Work Sheet (Attachment 2) will be completed by the Engineer for payment.

SMOOTHNESS ASSESSMENT SCHEDULE

Profile Index in./mile (mm/km) per Bridge Section	Smoothness Assessment per Bridge Section
15.0 (240) or less	+\$7,500.00
>15.0 (240) to 18.0 (285)	+\$5,000.00
>18.0 (285) to 20.0 (315)	+\$2,500.00
>20.0 (315) to 35.0 (555)	+\$0.00
>35.0 (555) to 45.0 (710)	+\$0.00
>45.0 (710)	-\$5,000.00

Method of Measurement. This work will be measured for payment in place and the area computed in square yards (square meters) of diamond grinding performed.

Basis of Payment. This work will be paid for at the contract unit price per square yard (square meter) for DIAMOND GRINDING (BRIDGE SECTION).

**INSTRUCTIONS FOR COMPLETING
PROFILOGRAPH REPORT OF BRIDGE SMOOTHNESS**

This form shall be prepared and submitted, along with the profile trace, to the Engineer.

The Type of Report is one of the following:

Information – Test conducted for informational purposes only.

Initial – Testing of bridge section prior to any corrective action.

Intermediate – After some corrective action has been completed.

Final – After all corrective action has been completed.

Other Information:

Structure Number – Numerical identification of the bridge.

Traffic Direction – NB, SB, EB, or WB depending on the design traffic flow of the numbered route.

Lane Designation – DL (Driving Lane), CL (Center Lane), or PL (Passing Lane).

Operator – Printed name of Contractor personnel operating profilograph.

Engineer – Printed name of Department representative witnessing data collection.

Bump locations are listed by station for each track (wheel path).

EXAMPLE

PROFILOGRAPH REPORT FOR BRIDGE SMOOTHNESS

Type of Report:

Information Initial Intermediate Final

Contract No. 96739

Route IL 255

Contractor John Doe Construction Co.

Section No. _____

Station 1795+06.0

County Madison

No. of Lanes 2

Structure Number 060-1234

Operator Joe Smith

Traffic Direction EB

Engineer Mike Jones

Date Tested 09/02/99

Section No.	Length mile (km)	Track 1 Measured Roughness in. (mm)	Track 1 Profile Index in./mile (mm/km)	Track 2 Measured Roughness in. (mm)	Track 2 Profile Index in./mile (mm/km)	Average Profile Index in./mile (mm/km)
1	0.100	2.16	21.6	1.30	13.0	17.3
2	0.100	2.18	21.8	2.26	22.6	22.2

Bump Locations: Track 1: 1893+53.5

Certified by: _____

Title: Chief Profilograph Pusher

Organization: John Doe Construction Co.

CONTAINMENT AND DISPOSAL OF NON-LEAD PAINT CLEANING RESIDUES

Effective: November 25, 2004

Revised: March 6, 2009

Description. This work shall consist of the containment, collection, temporary storage, transportation and disposal of waste from non-lead paint removal projects. Waste requiring containment and control includes, but is not limited to, old paint, spent abrasives, corrosion products, mill scale, dirt, dust, grease, oil, and salts.

General. This specification provides the requirements for the control of paint removal waste when the existing coatings do not contain lead. If the coatings contain lead, use specification "Containment and Disposal of Lead Paint Cleaning Residues." The Contractor shall take reasonable and appropriate precautions to protect the public from the inhalation or ingestion of dust and debris from their paint removal and clean up operations and is responsible for the clean-up of all spills of waste at no additional cost to the Department.

The Contractor shall comply with the requirements of this Specification and all applicable Federal, State, and Local laws, codes, and regulations, including, but not limited to the regulations of the United States Environmental Protection Agency (USEPA), Occupational Safety and Health Administration (OSHA), and Illinois Environmental Protection Agency (IEPA). The Contractor shall comply with all applicable regulations even if the regulation is not specifically referenced herein. If a Federal, State, or Local regulation is more restrictive than the requirements of this Specification, the more restrictive requirements shall prevail.

Submittals. The Contractor shall submit for Engineer review and acceptance, the following drawings and plans for accomplishing the work. The submittals shall be provided within 30 days of execution of the contract unless given written permission by the Engineer to submit them at a later date. Work cannot proceed until the submittals are accepted by the Engineer. Details for each of the plans are presented within the body of this specification.

- a) Containment Plans. The containment plans shall include drawings, equipment specifications, and calculations (e.g., wind load). The plans shall include copies of the manufacturer's specifications for the containment materials and equipment that will be used to accomplish containment and ventilation.
- b) When required by the contract plans, the containment submittal shall provide calculations that assure the structural integrity of the bridge when it supports the containment and the calculations and drawings shall be signed and sealed by a Structural Engineer licensed in the state of Illinois.

When working over the railroad or navigable waterways, the Department will notify the respective agencies that work is being planned. Unless otherwise directed by the Engineer, the Contractor is responsible for follow up contact, and shall provide evidence that the railroad, Coast Guard, Corps of Engineers, and other applicable agencies are satisfied with the clearance provided and other safety measures that are proposed.

- c) Waste Management Plan. The Waste Management Plan shall address all aspects of waste handling, storage, testing, hauling and disposal. Include the names, addresses, and a contact person for the proposed licensed waste haulers and disposal facilities. Submit the name and qualifications of the laboratory proposed for Toxicity Characteristic Leaching Procedure (TCLP) analysis.

- d) Contingency Plan. The Contractor shall prepare a contingency plan for emergencies including fire, accident, failure of power, failure of supplied air system or any other event that may require modification of standard operating procedures. The plan shall include specific procedures to ensure safe egress and proper medical attention in the event of an emergency.

When the Engineer accepts the submittals, the Contractor will receive written notification. The Contractor shall not begin any work until the Engineer has accepted the submittals. The Contractor shall not construe Engineer acceptance of the submittals to imply approval of any particular method or sequence for conducting the work, or for addressing health and safety concerns. Acceptance of the plans does not relieve the Contractor from the responsibility to conduct the work according to the requirements of Federal, State, or Local regulations, this specification, or to adequately protect the health and safety of all workers involved in the project and any members of the public who may be affected by the project. The Contractor remains solely responsible for the adequacy and completeness of the programs and work practices, and adherence to them.

Quality Control (QC) Inspections. The Contractor shall perform first line, in process QC inspections of all environmental control and waste handling aspects of the project to verify compliance with these specification requirements and the accepted drawings and plans. Contractor QC inspections shall include, but not be limited to the following:

- Proper installation and continued performance of the containment system(s) in accordance with the approved drawings.
- Visual inspections of emissions into the air and verification that the cause(s) for any unacceptable emissions is corrected.
- Visual inspections of spills or deposits of contaminated materials into the water or onto the ground, pavement, soil, or slope protection. Included is verification that proper cleanup is undertaken and that the cause(s) of unacceptable releases is corrected.
- Proper implementation of the waste management plan including laboratory analysis and providing the results to the Engineer within the time frames specified herein.
- Proper implementation of the contingency plans for emergencies.

Quality Assurance (QA) Observations. The Engineer will conduct QA observations of any or all of the QC monitoring inspections that are undertaken. The presence or activity of Engineer observations in no way relieves the Contractor of the responsibility to provide all necessary daily QC inspections of its own and to comply with all requirements of this Specification.

Containment Requirements. The Contractor shall install and maintain containment systems surrounding the work for the purpose of controlling emissions of dust and debris according to the requirements of this specification. Working platforms and containment materials that are used shall be firm and stable and platforms shall be designed to support the workers, inspectors, spent surface preparation media (e.g., abrasives), and equipment during all phases of surface preparation and painting. Platforms, cables, and other supporting structures shall be designed according to OSHA regulations. If the containment needs to be attached to the structure, the containment shall be attached by bolting, clamping, or similar means. Welding or drilling into the structure is prohibited unless approved by the Engineer in writing.

The containment shall be dropped in the event of sustained winds of 40 mph (64 kph) or greater and all materials and equipment secured.

The Contractor shall provide drawings showing the containment system and indicating the method(s) of supporting the working platforms and containment materials to each other and to the bridge.

When directed in the contract plans, the Contractor shall submit calculations and drawings, signed and sealed by a Structural Engineer licensed in the state of Illinois, that assure the structural integrity of the bridge under the live and dead loads imposed, including the design wind loading.

When working over railroads, the Contractor shall provide evidence that the proposed clearance and the safety provisions that will be in place (e.g., flagman) are acceptable to the railroad. In the case of work over navigable waters, the Contractor shall provide evidence that the proposed clearance and provisions for installing or moving the containment out of navigation lanes is acceptable to authorities such as the Coast Guard and Army Corps of Engineers. The Contractor shall include plans for assuring that navigation lighting is not obscured, or if it is obscured, that temporary lighting is acceptable to the appropriate authorities (e.g., Coast Guard) and will be utilized.

Engineer review and acceptance of the drawings and calculations shall not relieve the Contractor from the responsibility for the safety of the working platforms and containment. After the work platforms and containment materials are erected additional measures may be needed to ensure worker safety according to OSHA regulations. The Contractor shall institute such measures at no additional cost to the Department.

Containment for the cleaning operation of this contract is defined as follows:

- The containment system shall confine emissions of dust and debris to the property line.
- The containment systems shall comply with the specified SSPC Guide 6 classifications, as applicable, as presented in Table 1 for the method of paint removal utilized.

The Contractor shall take appropriate action to avoid personnel injury or damage to the structure from the installation and use of the containment system. If the Engineer determines that there is the potential for structural damage caused by the installed containment system, the Contractor shall take appropriate action to correct the situation.

The containment systems shall also meet the following requirements:

a) Dry Abrasive Blast Cleaning - (SSPC Class 2A)

The enclosure shall be designed, installed, and maintained to sustain maximum anticipated wind forces. Flapping edges of containment materials are prohibited and the integrity of all containment materials shall be maintained for the duration of the project. When the location of the work on the bridge, or over lane closures permit, the blast enclosure shall extend a minimum of 3 ft (1 m) beyond the limits of surface preparation to allow the workers to blast away from, rather than into the seam between the containment and the structure.

b) Vacuum Blast Cleaning

Vacuum blasting equipment shall be fully automatic and capable of cleaning and recycling the abrasive. The system shall be designed to deliver cleaned, recycled blasting abrasives and provide a closed system containment during blasting. The removed coating, mill scale, and corrosion shall be separated from the abrasive, and stored for disposal. No additional containment is required but escaping abrasive, paint chips, and debris shall be cleaned from the work area at the end of each day.

c) Power Tool Cleaning (SSPC-Class 3P)

The Contractor shall use containment materials (e.g., tarpaulins) to capture removed paint chips, rust, mill scale and other debris.

d) Vacuum-Shrouded Power Tool Cleaning/Hand Tool Cleaning

The Contractor shall utilize hand tools or power tools equipped with vacuums and High Efficiency Particulate Air (HEPA) filters. No additional containment is required but escaping and paint chips and debris shall be cleaned from the work area at the end of each day.

e) Water Jetting or Wet Abrasive Blast Cleaning for the Removal of Paint (SSPC Class 4W)

Water jetting or wet abrasive blast cleaning for the purpose of removing paint and surface debris shall be conducted within a containment designed, installed, and maintained in order to capture paint chips and debris. Collection of the water is not required. Mesh containment materials that capture paint chips and debris while allowing the water to pass through shall have openings a maximum of 25 mils (625 microns) in greatest dimension.

f) Water Washing

Water washing of the bridge for the purpose of removing chalk, dirt, grease, oil, bird nests, and other surface debris can be performed without additional containment provided paint chips and removed debris are removed and collected prior to washing or are cleaned from the site after cleaning is completed each day. At the Contractor's option, SSPC Class 4W permeable containment materials described above under "Water Jetting or Wet Abrasive Blast Cleaning for the Removal of Paint" can be used to collect the debris while the washing is underway.

Environmental Controls

- a) Cleanliness of ground and water. At the end of each workday at a minimum, the work area outside of containment, including any ground tarpaulins that are used, shall be inspected to verify that paint removal debris (e.g., paint chips, abrasives, rust, etc.) is not present. If debris is observed, it shall be removed by hand, shoveling, sweeping, or vacuuming.

Upon project completion, the ground and water in and around the project site are considered to have been properly cleaned if paint chips, paint removal media (e.g., spent abrasives), fuel, materials of construction, litter, or other project debris have been removed, even if the material being cleaned was a pre-existing condition.

- b) Visible Emissions. Emissions of dust and debris from the project shall not extend beyond the property line. If unacceptable visible emissions or releases beyond the property line are observed, the Contractor shall immediately shut down the emission-producing operations, clean up the debris, and change work practices, modify the containment, or take other appropriate corrective action as needed to prevent similar releases from occurring in the future.

Hygiene Facilities/Protective Clothing. The Contractor shall provide clean lavatory and hand washing facilities according to OSHA regulations and make them available to IDOT project personnel.

The Contractor shall provide IDOT project personnel with all required protective clothing and equipment, including disposal or cleaning. Clothing and equipment includes but is not limited to disposable coveralls with hood, booties, disposable surgical gloves, hearing protection, and safety glasses. The protective clothing and equipment shall be provided and maintained on the job site for the exclusive, continuous and simultaneous use by the IDOT personnel. This equipment shall be suitable to allow inspection access to any area in which work is being performed.

Site Emergencies.

- a) Stop Work. The Contractor shall stop work at any time the conditions are not within specifications and take the appropriate corrective action. The stoppage will continue until conditions have been corrected. Standby time and cost required for corrective action is at the Contractor's expense. The occurrence of the following events shall be reported in writing to IDOT and shall require the Contractor to automatically stop paint removal and initiate clean up activities.

- Break in containment barriers.
- Visible emissions in excess of the specification tolerances.
- Serious injury within the containment area.
- Fire or safety emergency
- Respiratory system failure
- Power failure

- b) Contingency Plans and Arrangements. The Engineer will refer to the contingency plan for site specific instructions in the case of emergencies.

The Contractor shall prepare a contingency plan for emergencies including fire, accident, failure of power, failure of supplied air system or any other event that may require modification of standard operating procedures during paint removal and painting processes. The plan shall include specific procedures to ensure safe egress and proper medical attention in the event of an emergency. The Contractor shall post the telephone numbers and locations of emergency services including fire, ambulance, doctor, hospital, police, power company and telephone company.

A two-way radio, or equal, as approved by the Engineer, capable of summoning emergency assistance shall be available at each bridge during the time the Contractor's personnel are at the bridge site under this contract.

The following emergency response equipment described in the contingency plan (generic form attached) shall be available during this time as well: an appropriate portable fire extinguisher, a 55 gal (208 L) drum, a 5 gal (19 L) pail, a long handled shovel, absorbent material (one bag).

A copy of the contingency plan shall be maintained at each bridge during cleaning operations and during the time the Contractor's personnel are at the bridge site under this contract. The Contractor shall designate the emergency coordinator(s) required who shall be responsible for the activities described.

An example of a contingency plan is included at the end of this Special Provision.

Collection, Temporary Storage, Transportation and Disposal of Waste.

All surface preparation/paint residues shall be collected daily and deposited in all-weather containers supplied by the Contractor as temporary storage. The storage area shall be secure to prevent unauthorized entry or tampering with the containers. Acceptable measures include storage within a fully enclosed (e.g., fenced in) and locked area, within a temporary building, or implementing other reasonable means to reduce the possibility of vandalism or exposure of the waste to the public or the environment (e.g., chains and locks to secure the covers of roll-off boxes). Waste shall not be stored outside of the containers.

No residues shall remain on uncontained surfaces overnight. Waste materials shall not be removed through floor drains or by throwing them over the side of the bridge. Flammable materials shall not be stored around or under any bridge structures.

The Contractor shall have each waste stream sampled for each project and tested by TCLP and according to EPA and disposal company requirements. The Engineer shall be notified in advance when the samples will be collected. The samples shall be collected and shipped for testing within the first week of the project, with the results due back to the Engineer within 10 days. Testing shall be considered included in the pay item for "Containment and Disposal of Non-Lead Paint Cleaning Residues." Copies of the test results shall be provided to the Engineer prior to shipping the waste. If the waste tests hazardous, the Contractor shall comply with all provision of "Collection, Temporary Storage, Transportation and Disposal of Waste" found in specification "Containment and Disposal of Lead Paint Cleaning Residues," except additional costs will be paid for according to Article 109.04.

If the waste is found to be non-hazardous as determined by TCLP testing, the waste shall be classified as a non-hazardous special waste, transported by a licensed waste transporter, and disposed of at an IEPA permitted disposal facility in Illinois.

The waste shall be shipped to the disposal facility within 90 days of the first accumulation of the waste in the containers. When permitted by the Engineer, waste from multiple bridges in the same contract may be transported by the Contractor to a central waste storage location(s) approved by the Engineer in order to consolidate the material for pick up, and to minimize the storage of waste containers at multiple remote sites after demobilization. Arrangements for the final waste pickup shall be made with the waste hauler by the time blast cleaning operations are completed or as required to meet the 90-day limit stated above.

All other project waste shall be removed from the site according to Federal, State and Local regulations, with all waste removed from the site prior to final Contractor demobilization.

The Contractor shall make arrangements to have other hazardous waste, which he/she generates, such as used paint solvent, transported to the Contractor's facility at the end of each day that this waste is generated. These hazardous wastes shall be manifested using the Contractor's own generator number to a treatment or disposal facility from the Contractor's facility. The Contractor shall not combine solvents or other wastes with cleaning residue wastes. All waste streams shall be stored in separate containers.

The Contractor is responsible for the payment of any fines and undertaking any clean up activities mandated by State or federal environmental agencies for improper waste handling, storage, transportation, or disposal.

Basis of Payment. The containment, collection, temporary storage, transportation, testing and disposal of all project waste, and all other work described herein will be paid for at the contract lump sum price for CONTAINMENT AND DISPOSAL OF NON-LEAD PAINT CLEANING RESIDUES at the designated location. Payment will not be authorized until all requirements have been fulfilled as described in this specification, including the submittal of waste test results, and disposal of all waste.

Table 1 Containment Criteria for Removal of Paint and Other Debris¹					
Removal Method	SSPC Class²	Containment Material Flexibility	Containment Material Permeability³	Containment Support Structure	Containment Material Joints
Hand Tool Cleaning	None	See Note 4	See Note 4	See Note 4	See Note 4
Power Tool Cleaning w/ Vacuum	None	See Note 4	See Note 4	See Note 4	See Note 4
Power Tool Cleaning w/o Vacuum ⁵	3P	Rigid or Flexible	Permeable	Minimal	Partially Sealed
Water Jetting, Wet Abrasive Blast ⁶	4W	Flexible	Permeable	Flexible or Minimal	Partially Sealed
Water Cleaning ⁷	None	See Note 7	See Note 7	See Note 7	See Note 7
Open Abrasive Blast Cleaning ⁸	2A	Rigid or Flexible	Impermeable	Rigid or Flexible	Fully Sealed
Vacuum Blast Cleaning	None	See Note 4	See Note 4	See Note 4	See Note 4

Table 1 (Continued) Containment Criteria for Removal of Paint and Other Debris¹					
Removal Method	SSPC Class²	Containment Entryway	Ventilation System Required	Negative Pressure Required	Exhaust Filtration Required
Hand Tool Cleaning	None	See Note 4	See Note 4	See Note 4	See Note 4
Power Tool Cleaning w/ Vacuum	None	See Note 4	See Note 4	See Note 4	See Note 4
Power Tool Cleaning w/o Vacuum ⁵	3P	Open Seam	No	No	No
Water Jetting, Wet Abrasive Blast ⁶	4W	Open Seam	No	No	No
Water Cleaning ⁷	None	See Note 7	See Note 7	See Note 7	See Note 7
Open Abrasive Blast Cleaning ⁸	2A	Resealable or Overlap	Yes	Yes	Yes
Vacuum Blast Cleaning	None	See Note 4	See Note 4	See Note 4	See Note 4

Notes:

¹This table provides general design criteria only. It does not guarantee that specific controls over emissions will occur because unique site conditions must be considered in the design. Other combinations of materials may provide controls over emissions equivalent to or greater than those combinations shown above.

²The SSPC Classification is based on SSPC Guide 6.

³Permeability addresses both air and water as appropriate. In the case of water removal methods, the containment materials must be resistant to water. When ground covers are used they shall be of sufficient strength to withstand the impact and weight of the debris and the equipment used for collection and clean-up.

⁴Containment is not required provided paint chips and debris are removed from the ground and surfaces in and around the worksite at the end of each day. Ground tarpaulins can be used to simplify the cleanup. At the Contractor's option, permeable containment materials may be suspended under the work area to capture the debris at the time of removal. Permeable materials for the purpose of this specification are defined as materials with openings measuring 25 mils or less in greatest dimension.

⁵This method involves open power tool cleaning. The containment consists of permeable materials suspended beneath the work area to capture debris. As an option, if the work is close to the ground or bridge deck, ground covers can be used to capture the paint chips and debris for proper disposal.

⁶This method involves water jetting (with and without abrasive) and wet abrasive blast cleaning where the goal is to remove paint. Permeable containment materials are used to capture removed paint chips, debris, and abrasives (in the case of wet abrasive blast cleaning) while allowing the water to pass through. Permeable materials for the purpose of this specification are defined as materials with openings measuring 25 mils (625 microns) or less in greatest dimension.

⁷Chips and debris can be removed from the ground at the end of each shift, or the Contractor can install a Class 4W containment in the work area to collect the debris while allowing the water to pass through (see note 6)

⁸This method involves dry abrasive blast cleaning. Dust and debris shall not be permitted to escape from the containment.

Containment Components - The basic components that make up containment systems are defined below. The components are combined in Table 1 to establish the minimum containment system requirements for the method(s) of paint removal specified for the Contract.

1. R Rigidity of Containment Materials - Rigid containment materials consist of solid panels of plywood, aluminum, rigid metal, plastic, fiberglass, composites, or similar materials. Flexible materials consist of screens, tarps, drapes, plastic sheeting, or similar materials. When directed by the Engineer, do not use flexible materials for horizontal surfaces directly over traffic lanes or vertical surfaces in close proximity to traffic lanes. If the Engineer allows the use of flexible materials, the Contractor shall take special precautions to completely secure the materials to prevent any interference with traffic.
2. Permeability of Containment Materials - The containment materials are identified as air impenetrable if they are impervious to dust or wind such as provided by rigid panels, coated solid tarps, or plastic sheeting. Air penetrable materials are those that are formed or woven to allow air flow. Water impermeable materials are those that are capable of containing and controlling water when wet methods of preparation are used. Water permeable materials allow the water to pass through. Chemical resistant materials are those resistant to chemical and solvent stripping solutions. Use fire retardant materials in all cases.
3. Support Structure - Rigid support structures consist of scaffolding and framing to which the containment materials are affixed to minimize movement of the containment cocoon. Flexible support structures are comprised of cables, chains, or similar systems to which the containment materials are affixed. Use fire retardant materials in all cases.
4. Containment Joints - Fully sealed joints require that mating surfaces between the containment materials and to the structure being prepared are completely sealed. Sealing measures include tape, caulk, Velcro, clamps, or other similar material capable of forming a continuous, impenetrable or impermeable seal. When materials are overlapped, a minimum overlap of 8 in. (200 mm) is required.
5. Entryway - An airlock entryway involves a minimum of one stage that is fully sealed to the containment and which is maintained under negative pressure using the ventilation system of the containment. Resealable door entryways involve the use of flexible or rigid doors capable of being repeatedly opened and resealed. Sealing methods include the use of zippers, Velcro, clamps, or similar fasteners. Overlapping door tarpaulin entryways consist of two or three overlapping door tarpaulins.
6. Mechanical Ventilation - The requirement for mechanical ventilation is to ensure that adequate air movement is achieved to reduce worker exposure to toxic metals to as low as feasible according to OSHA regulations (e.g., 29 CFR 1926.62), and to enhance visibility. Natural ventilation does not require the use of mechanical equipment for moving dust and debris through the work area.

7. Negative Pressure - When specified, achieve a minimum of 0.03 in.(7.5 mm) water column (W.C.) relative to ambient conditions, or confirm through visual assessments for the concave appearance of the containment enclosure.
8. Exhaust Ventilation - When mechanical ventilation systems are specified,, provide filtration of the exhaust air, to achieve a filtration efficiency of 99.9 percent at 0.5 microns.

CONTINGENCY PLAN
FOR
NON-LEAD BASED PAINT REMOVAL PROJECTS

Bridge No.: _____
Location: _____

Note:

1. A copy of this plan must be kept at the bridge while the Contractor's employees are at the site.
2. A copy of the plan must be mailed to the police and fire departments and hospital identified herein.

Primary Emergency Coordinator

Name: _____
Address: _____
City: _____
Phone: (Work) _____
(Home) _____

Alternate Emergency Coordinator

Name: _____
Address: _____
City: _____
Phone: (Work) _____
(Home) _____

Emergency Response Agencies

POLICE:

1. State Police (if bridge not in city) Phone: _____
District No. _____
Address: _____
2. County Sheriff _____ Phone: _____
County: _____
Address: _____
3. City Police _____ Phone: _____
District No. _____
Address: _____

Arrangements made with police: (Describe arrangements or refusal by police to make arrangements):

FIRE:

1. City _____ Phone: _____
Name: _____
Address: _____
2. Fire District _____ Phone: _____
Name: _____
Address: _____

3. Other _____ Phone: _____

Name: _____

Address: _____

Arrangements made with fire departments: (Describe arrangements or refusal by fire departments to make arrangements):

HOSPITAL:

Name: _____ Phone: _____

Address: _____

Arrangements made with hospital: (Describe arrangements or refusal by hospital to make arrangements):

Properties of waste and hazard to health:

Places where employees working:

Location of Bridge:

Types of injuries or illness which could result:

Appropriate response to release of waste to the soil:

Appropriate response to release of waste to surface water:

Emergency Equipment at Bridge

Emergency Equipment List	Location of Equipment	Description of Equipment	Capability of Equipment
1. Two-way radio	Truck		Communication
2. Portable Fire Extinguisher	Truck		Extinguishes Fire
3. Absorbent Material	Truck		Absorbs Paint or Solvent Spills
4. Hand Shovel	Truck		Scooping Material
5. 208 L (55 Gallon) Drum	Truck		Storing Spilled Material
6. 19 L (5 Gallon) Pail	Truck		Storing Spilled Material

Emergency Procedure

1. Notify personnel at the bridge of the emergency and implement emergency procedure.
2. Identify the character, source, amount and extent of released materials.
3. Assess possible hazards to health or environment.
4. Contain the released waste or extinguish fire. Contact the fire department if appropriate.
5. If human health or the environment is threatened, contact appropriate police and fire department. In addition, the Emergency Services and Disaster Agency needs to be called using their 24-hour toll free number (800-782-7860) and the National Response Center using their 24-hour toll free number (800-824-8802).
6. Notify the Engineer that an emergency has occurred.
7. Store spilled material and soil contaminated by spill, if any, in a drum or pail. Mark and label the drum or pail for disposal.
8. Write a full account of the spill or fire incident including date, time, volume, material, and response taken.
9. Replenish stock of absorbent material or other equipment used in response.

DEMOLITION PLANS FOR REMOVAL OF EXISTING STRUCTURES

Effective: September 5, 2007

Add to the beginning of Article 501.02 of the Standard Specifications.

“The Contractor shall submit a demolition plan to the Engineer for approval, detailing the proposed methods of demolition and the amount, location(s) and type(s) of equipment to be used. With the exception of removal of single box culverts, for work adjacent to or over an active roadway, railroad or navigable waterway, the demolition plan shall include an assessment of the structure’s condition and an evaluation of the structure’s strength and stability during demolition and shall be sealed by an Illinois Licensed Structural Engineer.”

PILING

Effective: May 11, 2009

Revised: January 22, 2010

Revise Article 512.04(a) of the Standard Specifications to read:

“(a) Splicing. Splicing of metal shell piles shall be as follows.

- (1) Planned Splices. Planned field or shop splices may be used when allowed per Article 512.10 or when the lengths specified in Article 512.16 exceed the estimated lengths specified in the contract plans by at least 10 ft (3 m). The location of planned splices shall be approved by the Engineer and located to minimize the chance they will occur within the 10 ft (3 m) below the base of the footing, abutment, or pier.
- (2) Unplanned Splices. Unplanned field splices shall be used as required to furnish lengths beyond those specified in Article 512.16. The length of additional segments shall be specified by the Engineer.”

Revise Article 512.05(a) of the Standard Specifications to read:

“(a) Splicing. Splicing of steel piles shall be as follows.

- (1) Planned Splices. Planned field or shop splices may be used when allowed per Article 512.10 or when the lengths specified in Article 512.16 exceed the estimated lengths specified in the contract plans by at least 10 ft (3 m). The location of planned splices shall be approved by the Engineer and located to minimize the chance they will occur within the 10 ft (3 m) below the base of the footing, abutment, or pier.
- (2) Unplanned Splices. Unplanned field splices shall be used as required to furnish lengths beyond those specified in Article 512.16. The length of additional segments shall be specified by the Engineer.”

Revise the first three paragraphs of Article 512.10 of the Standard Specifications to read:

“**512.10 Driving Equipment.** The equipment for driving piles shall be adequate for driving piles at least 10 ft (3 m) longer than the longest estimated pile length specified in the contract plans without splicing, unless the estimated pile length exceeds 55 ft (17 m) or prevented by vertical clearance restrictions.

The use of shorter length equipment or the use of preplanned splices (necessitated by estimated pile lengths exceeding 55 ft (17 m) or vertical clearance restrictions) shall meet the approval of the Engineer. The equipment for driving piles shall be according to the following.

- (a) Hammers. Piles shall be driven with an impact hammer such as a drop, steam/air, hydraulic, or diesel. The driving system selected by the Contractor shall not result in damage to the pile. The impact hammer shall be capable of being operated at an energy which will maintain a pile penetration rate between 1 and 10 blows per 1 in. (25 mm) when the nominal driven bearing of the pile approaches the nominal required bearing.

For hammer selection purposes, the minimum and maximum hammer energy necessary to achieve these penetrations may be estimated as follows.

$$E \geq \frac{32.90 R_N}{F_{eff}} \quad (\text{English})$$

$$E \leq \frac{65.80 R_N}{F_{eff}} \quad (\text{English})$$

$$E \geq \frac{10.00 R_N}{F_{eff}} \quad (\text{metric})$$

$$E \leq \frac{20.00 R_N}{F_{eff}} \quad (\text{metric})$$

Where:

- R_N = Nominal required bearing in kips (kN)
 E = Energy developed by the hammer per blow in ft lb (J)
 F_{eff} = Hammer efficiency factor according to Article 512.14.”

Add the following sentence to the beginning of the fourth paragraph of Article 512.11 of the Standard Specifications:

“Except as required to satisfy the minimum tip elevations required in 512.11(b) above, piles are not required to be driven more than one additional foot (300 mm) after the nominal driven bearing equals or exceeds the nominal required bearing; more than three additional inches (75 mm) after the nominal driven bearing exceeds 110 percent of the nominal required bearing; or more than one additional inch (25 mm) after the nominal driven bearing exceeds 150 percent of the nominal required bearing.”

Revise the first paragraph of Article 512.14 of the Standard Specifications to read:

“512.14 Determination of Nominal Driven Bearing. The nominal driven bearing of each pile shall be determined by the WSDOT formula as follows.

$$R_{NDB} = \frac{6.6 F_{eff} E \ln(10N_b)}{1000} \quad (\text{English})$$

$$R_{NDB} = \frac{21.7 F_{eff} E \ln(10N_b)}{1000} \text{ (metric)}$$

Where:

- R_{NDB} = Nominal driven bearing of the pile in kips (kN)
 N_b = Number of hammer blows per inch (25 mm) of pile penetration
 E = Energy developed by the hammer per blow in ft lb (J)
 F_{eff} = Hammer efficiency factor taken as:
0.55 for air/steam hammers
0.47 for open-ended diesel hammers and steel piles or metal shell piles
0.37 for open-ended diesel hammers and concrete or timber piles
0.35 for closed-ended diesel hammers
0.28 for drop hammers”

Add the following to Article 512.18 of the Standard Specifications.

“(h) When the lengths specified in Article 512.16 exceed the estimated lengths specified in the contract plans by at least 10 ft (3m), additional field splices (for metal shell and steel piles) required to provide the lengths specified in Article 512.16 will be paid for according to Article 109.04.”

ALKALI-SILICA REACTION FOR CAST-IN-PLACE CONCRETE (BDE)

Effective: August 1, 2007

Revised: January 1, 2009

Description. This special provision is intended to reduce the risk of a deleterious alkali-silica reaction in concrete exposed to humid or wet conditions. The special provision is not intended or adequate for concrete exposed to potassium acetate, potassium formate, sodium acetate or sodium formate. The special provision shall not apply to the dry environment (humidity less than 60 percent) found inside buildings for residential or commercial occupancy. The special provision shall also not apply to precast products or precast prestressed products.

Aggregate Expansion Values. Each coarse and fine aggregate will be tested by the Department for alkali reaction according to ASTM C 1260. The test will be performed with Type I or II cement having a total equivalent alkali content ($\text{Na}_2\text{O} + 0.658\text{K}_2\text{O}$) of 0.90 percent or greater. The Engineer will determine the assigned expansion value for each aggregate, and these values will be made available on the Department’s Alkali-Silica Potential Reactivity Rating List. The Engineer may differentiate aggregate based on ledge, production method, gradation number, or other factors. An expansion value of 0.05 percent will be assigned to limestone or dolomite coarse aggregates and 0.03 percent to limestone or dolomite fine aggregates (manufactured stone sand); however the Department reserves the right to perform the ASTM C 1260 test.

Aggregate Groups. Each combination of aggregates used in a mixture will be assigned to an aggregate group. The point at which the coarse aggregate and fine aggregate expansion values intersect in the following table will determine the group.

AGGREGATE GROUPS			
Coarse Aggregate or Coarse Aggregate Blend ASTM C 1260 Expansion	Fine Aggregate or Fine Aggregate Blend ASTM C 1260 Expansion		
	≤ 0.16%	> 0.16% - 0.27%	> 0.27%
≤ 0.16%	Group I	Group II	Group III
> 0.16% - 0.27%	Group II	Group II	Group III
> 0.27%	Group III	Group III	Group IV

Mixture Options. Based upon the aggregate group, the following mixture options shall be used; however, the Department may prohibit a mixture option if field performance shows a deleterious alkali-silica reaction or Department testing indicates the mixture may experience a deleterious alkali-silica reaction.

- Group I - Mixture options are not applicable. Use any cement or finely divided mineral.
- Group II - Mixture options 1, 2, 3, 4, or 5 shall be used.
- Group III - Mixture options 1, 2 and 3 combined, 4, or 5 shall be used.
- Group IV - Mixture options 1, 2 and 4 combined, or 5 shall be used.

For Class PP-3 concrete the mixture options are not applicable, and any cement may be used with the specified finely divided minerals.

- a) Mixture Option 1. The coarse or fine aggregates shall be blended to place the material in a group that will allow the selected cement or finely divided mineral to be used.

When a coarse or fine aggregate is blended, the weighted expansion value shall be calculated separately for the coarse and fine aggregate as follows:

$$\text{Weighted Expansion Value} = (a/100 \times A) + (b/100 \times B) + (c/100 \times C) + \dots$$

Where: a, b, c... = percentage of aggregate in the blend;
 A, B, C...= expansion value for that aggregate.

- b) Mixture Option 2. A finely divided mineral shall be used as described in 1), 2), 3), or 4) that follow. The replacement ratio is defined as “finely divided mineral:portland cement”.
 - 1) Class F Fly Ash. For Class PV, BS, MS, DS, SC, and SI concrete and cement aggregate mixture II (CAM II), Class F fly ash shall replace 15 percent of the portland cement at a minimum replacement ratio of 1.5:1.
 - 2) Class C Fly Ash. For Class PV, MS, SC, and SI Concrete, Class C fly ash with 18 percent to less than 26.5 percent calcium oxide content, and less than 2.0 percent loss on ignition, shall replace 20 percent of the portland cement at a minimum replacement ratio of 1:1; or at a minimum replacement ratio of 1.25:1 if the loss on ignition is 2.0 percent or greater. Class C fly ash with less than 18 percent calcium oxide content shall replace 20 percent of the portland cement at a minimum replacement ratio of 1.25:1.

For Class PP-1, RR, BS, and DS concrete and CAM II, Class C fly ash with less than 26.5 percent calcium oxide content shall replace 15 percent of the portland cement at a minimum replacement ratio of 1.5:1.

- 3) Ground Granulated Blast-Furnace Slag. For Class PV, BS, MS, SI, DS, and SC concrete, ground granulated blast-furnace slag shall replace 25 percent of the portland cement at a minimum replacement ratio of 1:1.

For Class PP-1 and RR concrete, ground granulated blast-furnace slag shall replace 15 percent of the portland cement at a minimum replacement ratio of 1.5:1.

For Class PP-2, ground granulated blast-furnace slag shall replace 25 to 30 percent of the portland cement at a minimum replacement ratio of 1:1.

- 4) Microsilica or High Reactivity Metakaolin. Microsilica solids or high reactivity metakaolin shall be added to the mixture at a minimum 25 lb/cu yd (15 kg/cu m) or 27 lb/cu yd (16 kg/cu m) respectively.
- c) Mixture Option 3. The cement used shall have a maximum total equivalent alkali content ($\text{Na}_2\text{O} + 0.658\text{K}_2\text{O}$) of 0.60 percent. When aggregate in Group II is involved, any finely divided mineral may be used with a portland cement.
- d) Mixture Option 4. The cement used shall have a maximum total equivalent alkali content ($\text{Na}_2\text{O} + 0.658\text{K}_2\text{O}$) of 0.45 percent. When aggregate in Group II or III is involved, any finely divided mineral may be used with a portland cement.
- e) Mixture Option 5. The proposed cement or finely divided mineral may be used if the ASTM C 1567 expansion value is ≤ 0.16 percent when performed on the aggregate in the concrete mixture with the highest ASTM C 1260 test result. The ASTM C 1567 test will be valid for two years, unless the Engineer determines the materials have changed significantly. For latex concrete, the ASTM C 1567 test shall be performed without the latex. The 0.20 percent autoclave expansion limit in ASTM C 1567 shall not apply.

If during the two year time period the Contractor needs to replace the cement, and the replacement cement has an equal or lower total equivalent alkali content ($\text{Na}_2\text{O} + 0.658\text{K}_2\text{O}$), a new ASTM C 1567 test will not be required.

Testing. If an individual aggregate has an ASTM C 1260 expansion value > 0.16 percent, an ASTM C 1293 test may be performed by the Contractor to evaluate the Department's ASTM C 1260 test result. The ASTM C 1293 test shall be performed with Type I or II cement having a total equivalent alkali content ($\text{Na}_2\text{O} + 0.658\text{K}_2\text{O}$) of 0.80 percent or greater. The interior vertical wall of the ASTM C 1293 recommended container (pail) shall be half covered with a wick of absorbent material consisting of blotting paper. If the testing laboratory desires to use an alternate container or wick of absorbent material, ASTM C 1293 test results with an alkali-reactive aggregate of known expansion characteristics shall be provided to the Engineer for review and approval. If the expansion is less than 0.040 percent after one year, the aggregate will be assigned an ASTM C 1260 expansion value of 0.08 percent that will be valid for two years, unless the Engineer determines the aggregate has changed significantly.

The Engineer reserves the right to verify a Contractor's ASTM C 1293 or 1567 test result. The Engineer will not accept the result if the precision and bias for the test methods are not met.

The laboratory performing the ASTM C 1567 test shall either be accredited by the AASHTO Materials Reference Laboratory (AMRL) for ASTM C 227 under Portland Cement Concrete or Aggregate; or shall be inspected for Hydraulic Cement - Physical Tests by the Cement and Concrete Reference Laboratory (CCRL) and shall be approved by the Department. The laboratory performing the ASTM C 1293 test shall be inspected for Portland Cement Concrete by CCRL and shall be approved by the Department.

ALKALI-SILICA REACTION FOR PRECAST AND PRECAST PRESTRESSED CONCRETE (BDE)

Effective: January 1, 2009

Description. This special provision is intended to reduce the risk of a deleterious alkali-silica reaction in precast and precast prestressed concrete exposed to humid or wet conditions. The special provision is not intended or adequate for concrete exposed to potassium acetate, potassium formate, sodium acetate or sodium formate. The special provision shall not apply to the dry environment (humidity less than 60 percent) found inside buildings for residential or commercial occupancy. The special provision shall also not apply to cast-in-place concrete.

Aggregate Expansion Values. Each coarse and fine aggregate will be tested by the Department for alkali reaction according to ASTM C 1260. The test will be performed with Type I or II cement having a total equivalent alkali content ($\text{Na}_2\text{O} + 0.658\text{K}_2\text{O}$) of 0.90 percent or greater. The Engineer will determine the assigned expansion value for each aggregate, and these values will be made available on the Department's Alkali-Silica Potential Reactivity Rating List. The Engineer may differentiate aggregate based on ledge, production method, gradation number, or other factors. An expansion value of 0.05 percent will be assigned to limestone or dolomite coarse aggregates and 0.03 percent to limestone or dolomite fine aggregates (manufactured stone sand); however the Department reserves the right to perform the ASTM C 1260 test.

Aggregate Groups. Each combination of aggregates used in a mixture will be assigned to an aggregate group. The point at which the coarse aggregate and fine aggregate expansion values intersect in the following table will determine the group.

AGGREGATE GROUPS			
Coarse Aggregate or Coarse Aggregate Blend ASTM C 1260 Expansion	Fine Aggregate or Fine Aggregate Blend ASTM C 1260 Expansion		
	≤ 0.16%	> 0.16% - 0.27%	> 0.27%
≤ 0.16%	Group I	Group II	Group III
> 0.16% - 0.27%	Group II	Group II	Group III
> 0.27%	Group III	Group III	Group IV

Options. Based upon the aggregate group, the following mixture options shall be used; however, the Department may prohibit a mixture option if field performance shows a deleterious alkali-silica reaction or Department testing indicates the mixture may experience a deleterious alkali-silica reaction.

- Group I - Mixture options are not applicable. Use any cement or finely divided mineral.
- Group II - Mixture options 1, 2, 3, 4, or 5 shall be used.
- Group III - Mixture options 1, 2 and 3 combined, 4, or 5 shall be used.
- Group IV - Mixture options 1, 2 and 4 combined, or 5 shall be used.

- a) Mixture Option 1. The coarse or fine aggregates shall be blended to place the material in a group that will allow the selected cement or finely divided mineral to be used.

When a coarse or fine aggregate is blended, the weighted expansion value shall be calculated separately for the coarse and fine aggregate as follows:

$$\text{Weighted Expansion Value} = (a/100 \times A) + (b/100 \times B) + (c/100 \times C) + \dots$$

Where: a, b, c... = percentage of aggregate in the blend;
A, B, C...= expansion value for that aggregate.

- b) Mixture Option 2. A finely divided mineral shall be used as described in 1), 2), 3), or 4) that follow. The replacement ratio is defined as “finely divided mineral:portland cement”.
 - 1) Class F Fly Ash. For Class PC concrete, precast products, and PS concrete, Class F fly ash shall replace 15 percent of the portland cement at a minimum replacement ratio of 1.5:1.
 - 2) Class C Fly Ash. For Class PC Concrete, precast products, and Class PS concrete, Class C fly ash with 18 percent to less than 26.5 percent calcium oxide content, and less than 2.0 percent loss on ignition, shall replace 20 percent of the portland cement at a minimum replacement ratio of 1:1; or at a minimum replacement ratio of 1.25:1 if the loss on ignition is 2.0 percent or greater. Class C fly ash with less than 18 percent calcium oxide content shall replace 20 percent of the portland cement at a minimum replacement ratio of 1.25:1.
 - 3) Ground Granulated Blast-Furnace Slag. For Class PC concrete, precast products, and Class PS concrete, ground granulated blast-furnace slag shall replace 25 percent of the portland cement at a minimum replacement ratio of 1:1.
 - 4) Microsilica or High Reactivity Metakaolin. Microsilica solids or high reactivity metakaolin shall be added to the mixture at a minimum 25 lb/cu yd (15 kg/cu m) or 27 lb/cu yd (16 kg/cu m) respectively.
- c) Mixture Option 3. The cement used shall have a maximum total equivalent alkali content ($\text{Na}_2\text{O} + 0.658\text{K}_2\text{O}$) of 0.60 percent. When aggregate in Group II is involved, any finely divided mineral may be used with a portland cement.

- d) Mixture Option 4. The cement used shall have a maximum total equivalent alkali content ($\text{Na}_2\text{O} + 0.658\text{K}_2\text{O}$) of 0.45 percent. When aggregate in Group II or III is involved, any finely divided mineral may be used with a portland cement.
- e) Mixture Option 5. The proposed cement or finely divided mineral may be used if the ASTM C 1567 expansion value is ≤ 0.16 percent when performed on the aggregate in the concrete mixture with the highest ASTM C 1260 test result. The ASTM C 1567 test will be valid for two years, unless the Engineer determines the materials have changed significantly. The 0.20 percent autoclave expansion limit in ASTM C 1567 shall not apply.

If during the two year time period the Contractor needs to replace the cement, and the replacement cement has an equal or lower total equivalent alkali content ($\text{Na}_2\text{O} + 0.658\text{K}_2\text{O}$), a new ASTM C 1567 test will not be required.

Testing. If an individual aggregate has an ASTM C 1260 expansion value > 0.16 percent, an ASTM C 1293 test may be performed by the Contractor to evaluate the Department's ASTM C 1260 test result. The ASTM C 1293 test shall be performed with Type I or II cement having a total equivalent alkali content ($\text{Na}_2\text{O} + 0.658\text{K}_2\text{O}$) of 0.80 percent or greater. The interior vertical wall of the ASTM C 1293 recommended container (pail) shall be half covered with a wick of absorbent material consisting of blotting paper. If the testing laboratory desires to use an alternate container or wick of absorbent material, ASTM C 1293 test results with an alkali-reactive aggregate of known expansion characteristics shall be provided to the Engineer for review and approval. If the expansion is less than 0.040 percent after one year, the aggregate will be assigned an ASTM C 1260 expansion value of 0.08 percent that will be valid for two years, unless the Engineer determines the aggregate has changed significantly.

The Engineer reserves the right to verify a Contractor's ASTM C 1293 or 1567 test result. The Engineer will not accept the result if the precision and bias for the test methods are not met.

The laboratory performing the ASTM C 1567 test shall either be accredited by the AASHTO Materials Reference Laboratory (AMRL) for ASTM C 227 under Portland Cement or Aggregate; or shall be inspected for Hydraulic Cement - Physical Tests by the Cement and Concrete Reference Laboratory (CCRL) and shall be approved by the Department. The laboratory performing the ASTM C 1293 test shall be inspected for Portland Cement Concrete by CCRL and shall be approved by the Department.

APPROVAL OF PROPOSED BORROW AREAS, USE AREAS, AND/OR WASTE AREAS INSIDE ILLINOIS STATE BORDERS (BDE)

Effective: November 1, 2008

Revise the title of Article 107.22 of the Standard Specifications to read:

"107.22 Approval of Proposed Borrow Areas, Use Areas, and/or Waste Areas Inside Illinois State Borders."

Add the following sentence to the end of the first paragraph of Article 107.22 of the Standard Specifications:

“Proposed borrow areas, use areas, and/or waste areas outside of Illinois shall comply with Article 107.01.”

AUTOMATED FLAGGER ASSISTANCE DEVICES (BDE)

Effective: January 1, 2008

Description. This work shall consist of furnishing and operating automated flagger assistance devices (AFADs) as part of the work zone traffic control and protection for two-lane highways where two-way traffic is maintained over one lane of pavement. Use of these devices shall be at the option of the Contractor.

Equipment. AFADs shall be according to the FHWA memorandum, “MUTCD - Revised Interim Approval for the use of Automated Flagger Assistance Devices in Temporary Traffic Control Zones (IA-4R)”, dated January 28, 2005. The devices shall be mounted on a trailer or a moveable cart and shall meet the requirements of NCHRP 350, Category 4.

The AFAD shall be the Stop/Slow type. This device uses remotely controlled “STOP” and “SLOW” signs to alternately control right-of-way.

Signs for the AFAD shall be according to Article 701.03 of the Standard Specifications and the MUTCD. The signs shall be 24 x 24 in. (600 x 600 mm) having an octagon shaped “STOP” sign on one side and a diamond shaped “SLOW” sign on the opposite side. The letters on the signs shall be 8 in. (200 mm) high. If the “STOP” sign has louvers, the full sign face shall be visible at a distance of 50 ft (15 m) and greater.

The signs shall be supplemented with one of the following types of lights.

- (a) Flashing Lights. When flashing lights are used, white or red flashing lights shall be mounted within the “STOP” sign face and white or yellow flashing lights within the “SLOW” sign face.
- (b) Stop and Warning Beacons. When beacons are used, a stop beacon shall be mounted 24 in. (600 mm) or less above the “STOP” sign face and a warning beacon mounted 24 in. (600 mm) or less above, below, or to the side of the “SLOW” sign face. As an option, a Type B warning light may be used in lieu of the warning beacon.

A “WAIT ON STOP” sign shall be placed on the right hand side of the roadway at a point where drivers are expected to stop. The sign shall be 24 x 30 in. (600 x 750 mm) with a black legend and border on a white background. The letters shall be at least 6 in. (150 mm) high.

This device may include a gate arm or mast arm that descends to a horizontal position when the “STOP” sign is displayed and rises to a vertical position when the “SLOW” sign is displayed. When included, the end of the arm shall reach at least to the center of the lane being controlled. The arm shall have alternating red and white retroreflective stripes, on both sides, sloping downward at 45 degrees toward the side on which traffic will pass. The stripes shall be 6 in. (150 mm) in width and at least 2 in. (50 mm) in height.

Flagging Requirements. Flaggers and flagging requirements shall be according to Article 701.13 of the Standard Specifications and the following.

AFADs shall be placed at each end of the traffic control, where a flagger is shown on the plans. The flaggers shall be able to view the face of the AFAD and approaching traffic during operation.

To stop traffic, the "STOP" sign shall be displayed, the corresponding lights/beacon shall flash, and when included, the gate arm shall descend to a horizontal position. To permit traffic to move, the "SLOW" sign shall be displayed, the corresponding lights/beacon shall flash, and when included, the gate arm shall rise to a vertical position.

If used at night, the AFAD location shall be illuminated according to Section 701 of the Standard Specifications.

When not in use, AFADs will be considered nonoperating equipment and shall be stored according to Article 701.11 of the Standard Specifications.

Basis of Payment. This work will not be paid for separately but shall be considered as included in the cost of the various traffic control items included in the contract.

CEMENT (BDE)

Effective: January 1, 2007

Revised: April 1, 2009

Revise Section 1001 of the Standard Specifications to read:

"SECTION 1001. CEMENT

1001.01 Cement Types. Cement shall be according to the following.

- (a) Portland Cement. Acceptance of portland cement shall be according to the current Bureau of Materials and Physical Research's Policy Memorandum, "Portland or Blended Cement Acceptance Procedure for Qualified and Non-Qualified Plants".

Portland cement shall be according to ASTM C 150, and shall meet the standard physical and chemical requirements. Type I or Type II may be used for cast-in-place, precast, and precast prestressed concrete. Type III may be used according to Article 1020.04, or when approved by the Engineer. All other cements referenced in ASTM C 150 may be used when approved by the Engineer.

The total of all organic processing additions shall be a maximum of 1.0 percent by weight (mass) of the cement. The total of all inorganic processing additions shall be a maximum of 4.0 percent by weight (mass) of the cement. However, a cement kiln dust inorganic processing addition shall be limited to a maximum of 1.0 percent. Organic processing additions shall be limited to grinding aids that improve the flowability of cement, reduce pack set, and improve grinding efficiency. Inorganic processing additions shall be limited to granulated blast-furnace slag according to the chemical requirements of AASHTO M 302, Class C fly ash according to the chemical requirements of AASHTO M 295, and cement kiln dust.

- (b) Portland-Pozzolan Cement. Acceptance of portland-pozzolan cement shall be according to the current Bureau of Materials and Physical Research's Policy Memorandum, "Portland or Blended Cement Acceptance Procedure for Qualified and Non-Qualified Plants".

Portland-pozzolan cement shall be according to ASTM C 595 and shall meet the standard physical and chemical requirements. Type IP may be used for cast-in-place, precast, and precast prestressed concrete, except when Class PP concrete is used. The pozzolan constituent for Type IP shall be a maximum of 21 percent of the weight (mass) of the portland-pozzolan cement.

For cast-in-place construction, portland-pozzolan cement shall not be used in concrete mixtures when the air temperature is below 40 °F (4 °C) without permission of the Engineer. If permission is given, the mix design strength requirement may require the Contractor to increase the cement or eliminate the cement factor reduction for a water-reducing or high range water-reducing admixture which is permitted according to Article 1020.05(b).

The total of all organic processing additions shall be a maximum of 1.0 percent by weight (mass) of the cement. Organic processing additions shall be limited to grinding aids as defined in (a) above. Inorganic processing additions shall be limited to cement kiln dust at a maximum of 1.0 percent.

- (c) Portland Blast-Furnace Slag Cement. Acceptance of portland blast-furnace slag cement shall be according to the current Bureau of Materials and Physical Research's Policy Memorandum, "Portland or Blended Cement Acceptance Procedure for Qualified and Non-Qualified Plants".

Portland blast-furnace slag cement shall be according to ASTM C 595 and shall meet the standard physical and chemical requirements. Type IS portland blast-furnace slag cement may be used for cast-in-place, precast, and precast prestressed concrete, except when Class PP concrete is used. The blast-furnace slag constituent for Type IS shall be a maximum of 25 percent of the weight (mass) of the portland blast-furnace slag cement.

For cast-in-place construction, portland blast-furnace slag cement shall not be used in concrete mixtures when the air temperature is below 40 °F (4 °C) without permission of the Engineer. If permission is given, the mix design strength requirement may require the Contractor to increase the cement or eliminate the cement factor reduction for a water-reducing or high range water-reducing admixture which is permitted according to Article 1020.05(b).

The total of all organic processing additions shall be a maximum of 1.0 percent by weight (mass) of the cement. Organic processing additions shall be limited to grinding aids as defined in (a) above. Inorganic processing additions shall be limited to cement kiln dust at a maximum of 1.0 percent.

- (d) Rapid Hardening Cement. Rapid hardening cement shall be used according to Article 1020.04 or when approved by the Engineer.

The cement shall be on the Department's current "Approved List of Packaged, Dry, Rapid Hardening Cementitious Materials for Concrete Repairs", and shall be according to the following.

- (1) The cement shall have a maximum final set of 25 minutes, according to Illinois Modified ASTM C 191.
 - (2) The cement shall have a minimum compressive strength of 2000 psi (13,800 kPa) at 3.0 hours, 3200 psi (22,100 kPa) at 6.0 hours, and 4000 psi (27,600 kPa) at 24.0 hours, according to Illinois Modified ASTM C 109.
 - (3) The cement shall have a maximum drying shrinkage of 0.050 percent at seven days, according to Illinois Modified ASTM C 596.
 - (4) The cement shall have a maximum expansion of 0.020 percent at 14 days, according to Illinois Modified ASTM C 1038.
 - (5) The cement shall have a minimum 80 percent relative dynamic modulus of elasticity; and shall not have a weight (mass) gain in excess of 0.15 percent or a weight (mass) loss in excess of 1.0 percent, after 100 cycles, according to AASHTO T 161, Procedure B.
- (e) Calcium Aluminate Cement. Calcium aluminate cement shall be used only where specified by the Engineer. The cement shall meet the standard physical requirements for Type I cement according to ASTM C 150, except the time of setting shall not apply. The chemical requirements shall be determined according to ASTM C 114 and shall be as follows: minimum 38 percent aluminum oxide (Al_2O_3), maximum 42 percent calcium oxide (CaO), maximum 1 percent magnesium oxide (MgO), maximum 0.4 percent sulfur trioxide (SO_3), maximum 1 percent loss on ignition, and maximum 3.5 percent insoluble residue.

1001.02 Uniformity of Color. Cement contained in single loads or in shipments of several loads to the same project shall not have visible differences in color.

1001.03 Mixing Brands and Types. Different brands or different types of cement from the same manufacturing plant, or the same brand or type from different plants shall not be mixed or used alternately in the same item of construction unless approved by the Engineer.

1001.04 Storage. Cement shall be stored and protected against damage, such as dampness which may cause partial set or hardened lumps. Different brands or different types of cement from the same manufacturing plant, or the same brand or type from different plants shall be kept separate."

CONCRETE ADMIXTURES (BDE)

Effective: January 1, 2003

Revised: April 1, 2009

Replace the first paragraph of Article 1020.05(b) of the Standard Specifications to read:

“(b) Admixtures. The use of admixtures to increase the workability or to accelerate the hardening of the concrete will be permitted when approved by the Engineer. Admixture dosages shall result in the mixture meeting the specified plastic and hardened properties. The Department will maintain an Approved List of Corrosion Inhibitors. Corrosion inhibitor dosage rates shall be according to Article 1020.05(b)(12). The Department will also maintain an Approved List of Concrete Admixtures, and an admixture technical representative shall be consulted when determining an admixture dosage from this list. The dosage shall be within the range indicated on the approved list unless the influence by other admixtures, jobsite conditions (such as a very short haul time), or other circumstances warrant a dosage outside the range. The Engineer shall be notified when a dosage is proposed outside the range. To determine an admixture dosage, air temperature, concrete temperature, cement source and quantity, finely divided mineral sources(s) and quantity, influence of other admixtures, haul time, placement conditions, and other factors as appropriate shall be considered. The Engineer may request the Contractor to have a batch of concrete mixed in the lab or field to verify the admixture dosage is correct. An admixture dosage or combination of admixture dosages shall not delay the initial set of concrete by more than one hour. When a retarding admixture is required or appropriate for a bridge deck or bridge deck overlay pour, the initial set time shall be delayed until the deflections due to the concrete dead load are no longer a concern for inducing cracks in the completed work. However, a retarding admixture shall not be used to further extend the pour time and justify the alteration of a bridge deck pour sequence.

When determining water in admixtures for water/cement ratio, the Contractor shall calculate 70 percent of the admixture dosage as water, except a value of 50 percent shall be used for a latex admixture used in bridge deck latex concrete overlays.”

Revise Section 1021 of the Standard Specifications to read:

“SECTION 1021. CONCRETE ADMIXTURES

1021.01 General. Admixtures shall be furnished in liquid form ready for use. The admixtures shall be delivered in the manufacturer's original containers, bulk tank trucks or such containers or tanks as are acceptable to the Engineer. Delivery shall be accompanied by a ticket which clearly identifies the manufacturer and trade name of the material. Containers shall be readily identifiable as to manufacturer and trade name of the material they contain.

Corrosion inhibitors will be maintained on the Department's Approved List of Corrosion Inhibitors. All other concrete admixture products will be maintained on the Department's Approved List of Concrete Admixtures. For the admixture submittal, a report prepared by an independent laboratory accredited by the AASHTO Materials Reference Laboratory (AMRL) for Portland Cement Concrete shall be provided. The report shall show the results of physical tests conducted no more than five years prior to the time of submittal, according to applicable specifications. However, for corrosion inhibitors the ASTM G 109 test information specified in ASTM C 1582 is not required to be from and independent lab. All other information in ASTM C 1582 shall be from and independent lab.

Tests shall be conducted using materials and methods specified on a "test" concrete and a "reference" concrete, together with a certification that no changes have been made in the formulation of the material since the performance of the tests.

Per the manufacturer's option, the cement content for all required tests shall either be according to applicable specifications or 5.65 cwt/cu yd (335 kg/cu m). Compressive strength test results for six months and one year will not be required.

Prior to the approval of an admixture, the Engineer reserves the right to request a sample for testing. The test and reference concrete mixtures tested by the Engineer will contain a cement content of 5.65 cwt/cu yd (335 kg/cu m). For freeze-thaw testing, the Department will perform the test according to AASHTO T 161, Procedure B. The flexural strength test will be performed according to AASHTO T 177. If the Engineer decides to test the admixture, the manufacturer shall submit AASHTO T 197 water content and set time test results on the standard cement used by the Department. The test and reference concrete mixture shall contain a cement content of 5.65 cwt/cu yd (335 kg/cu m). The manufacturer may select their lab or an independent lab to perform this testing. The laboratory is not required to be accredited by AASHTO.

The manufacturer shall include in the submittal the following admixture information: the manufacturing range for specific gravity, the midpoint and manufacturing range for residue by oven drying, and the manufacturing range for pH. The submittal shall also include an infrared spectrophotometer trace no more than five years old.

For air-entraining admixtures according to Article 1021.02, the specific gravity allowable manufacturing range shall be established by the manufacturer and the test method shall be according to ASTM C 494. For residue by oven drying and pH, the allowable manufacturing range and test methods shall be according to ASTM C 260.

For admixtures according to Articles 1021.03, 1021.04, 1021.05, 1021.06, and 1021.07, the pH allowable manufacturing range shall be established by the manufacturer and the test method shall be according to ASTM E 70. For specific gravity and residue by oven drying, the allowable manufacturing range and test methods shall be according to ASTM C 494.

When test results are more than seven years old, the manufacturer shall re-submit the infrared spectrophotometer trace and the report prepared by an independent laboratory accredited by AASHTO.

All admixtures, except chloride-based accelerators, shall contain a maximum of 0.3 percent chloride by weight (mass).

Random field samples may be taken by the Department to verify an admixture meets specification. A split sample will be provided to the manufacturer if requested. Admixtures that do not meet specification requirements or an allowable manufacturing range established by the manufacturer shall be replaced with new material.

1021.02 Air-Entraining Admixtures. Air-entraining admixtures shall be according to AASHTO M 154.

1021.03 Retarding and Water-Reducing Admixtures. The admixture shall be according to the following.

- (a) The retarding admixture shall be according to AASHTO M 194, Type B (retarding) or Type D (water-reducing and retarding).
- (b) The water-reducing admixture shall be according to AASHTO M 194, Type A.
- (c) The high range water-reducing admixture shall be according to AASHTO M 194, Type F (high range water-reducing) or Type G (high range water-reducing and retarding).

1021.04 Accelerating Admixtures. The admixture shall be according to AASHTO M 194, Type C (accelerating) or Type E (water reducing and accelerating).

1021.05 Self-Consolidating Admixtures. The self-consolidating admixture system shall consist of either a high range water-reducing admixture only or a high range water-reducing admixture combined with a separate viscosity modifying admixture. The one or two component admixture system shall be capable of producing a concrete mixture that can flow around reinforcement and consolidate under its own weight without additional effort and without segregation.

The high range water-reducing admixture shall be according to AASHTO M 194, Type F.

The viscosity modifying admixture shall be according to ASTM C 494, Type S (specific performance).

1021.06 Rheology-Controlling Admixture. The rheology-controlling admixture shall be capable of producing a concrete mixture with a lower yield stress that will consolidate easier for slipform applications used by the Contractor. The rheology-controlling admixture shall be according to ASTM C 494, Type S (specific performance).

1021.07 Corrosion Inhibitor. The corrosion inhibitor shall be according to one of the following.

- (a) Calcium Nitrite. The corrosion inhibitor shall contain a minimum 30 percent calcium nitrite by weight (mass) of solution, and shall comply with the requirements of AASHTO M 194, Type C (accelerating).
- (b) Other Materials. The corrosion inhibitor shall be according to ASTM C 1582.”

CONCRETE MIX DESIGNS (BDE)

Effective: April 1, 2009

Add the following to Article 1020.05(c) of the Standard Specifications:

- “(5) Performance Based Finely Divided Mineral Combination. For Class PV and SI concrete a performance based finely divided mineral combination may be used. The minimum cement factor, maximum cement factor, and water cement ratio of Article 1020.04 shall be replaced with the values below, and the performance based finely divided mineral combination herein is an alternative to Articles 1020.05(c)(1), (c)(2), (c)(3), and (c)(4). The mix design shall meet the following requirements and the Engineer may request a trial batch.

- a. The mixture shall contain a minimum of 375 lbs/cu yd (222 kg/cu m) of portland cement. For a blended cement, a sufficient amount shall be used to obtain the required 375 lbs/cu yd (222 kg/cu m) of portland cement in the mixture. For example, a blended cement stated to have 20 percent finely divided mineral, ignoring any ASTM C 595 tolerance on the 20 percent, would require a minimum of 469 lbs/cu yd (278 kg/cu m) of material in the mixture. When the mixture is designed for cement content from 375 lbs/cu yd (222 kg/cu m) to 400 lbs/cu yd (237 kg/cu m), the total of organic processing additions, inorganic processing additions, and limestone addition in the cement shall not exceed 5.0 percent.
- b. The mixture shall contain a maximum of two finely divided minerals. The finely divided mineral in a blended cement shall count toward the total number of finely divided minerals allowed. The finely divided mineral(s) shall constitute a maximum of 35.0 percent of the total cement plus finely divided mineral(s). The fly ash portion shall not exceed 30.0 percent for Class C fly ash or 25.0 percent for Class F fly ash. The Class C and F fly ash combination shall not exceed 30.0 percent. The ground granulated blast-furnace slag portion shall not exceed 35.0 percent. The microsilica or high-reactivity metakaolin portion used together or separately shall not exceed 5.0 percent. The finely divided mineral in the blended cement shall apply to the maximum 35.0 percent, and shall be determined as discussed in a. above for determining portland cement in blended cement.
- c. For central mixed Class PV and SI concrete, the mixture shall contain a minimum of 535 lbs/cu yd (320 kg/cu m) of cement and finely divided mineral(s) summed together, and a water-reducing admixture shall be used. The value shall be 565 lbs/cu yd (335 kg/cu m) without a water-reducing admixture.

For truck mixed or shrink mixed Class PV and SI concrete, the mixture shall contain a minimum of 575 lbs/cu yd (345 kg/cu m) of cement and finely divided mineral(s) summed together, and a water-reducing admixture shall be used. The value shall be 605 lbs/cu yd (360 kg/cu m) without a water-reducing admixture.

- d. The mixture shall contain a maximum of 705 lbs/cu yd (418 kg/cu m) of cement and finely divided mineral(s) summed together.
- e. The mixture shall have a water/cement ratio of 0.32 – 0.44.
- f. The mixture shall not be used for placement underwater.
- g. The combination of cement and finely divided mineral(s) shall have an ASTM C 1567 expansion value ≤ 0.16 percent, and shall be performed on the aggregate in the concrete mixture with the highest ASTM C 1260 test result. The ASTM C 1567 test will be valid for two years, unless the Engineer determines the materials have changed significantly.

If during the two year time period the Contractor needs to replace the portland cement, and the replacement portland cement has an equal or lower total equivalent alkali content ($\text{Na}_2\text{O} + 0.658\text{K}_2\text{O}$), a new ASTM C 1567 test will not be required. However, replacement of a blended cement with another cement will require a new ASTM C 1567 test.”

CONSTRUCTION AIR QUALITY - DIESEL VEHICLE EMISSIONS CONTROL (BDE)

Effective: April 1, 2009

Revised: July 1, 2009

Diesel Vehicle Emissions Control. The reduction of construction air emissions shall be accomplished by using cleaner burning diesel fuel. The term “equipment” refers to any and all diesel fuel powered devices rated at 50 hp and above, to be used on the project site in excess of seven calendar days over the course of the construction period on the project site (including any “rental” equipment).

All equipment on the jobsite, with engine ratings of 50 hp and above, shall be required to: use Ultra Low Sulfur Diesel fuel (ULSD) exclusively (15 ppm sulfur content or less).

Diesel powered equipment in non-compliance will not be allowed to be used on the project site, and is also subject to a notice of non-compliance as outlined below.

The Contractor shall submit copies of monthly summary reports and include certified copies of the ULSD diesel fuel delivery slips for diesel fuel delivered to the jobsite for the reporting time period, noting the quantity of diesel fuel used.

If any diesel powered equipment is found to be in non-compliance with any portion of this specification, the Engineer will issue the Contractor a notice of non-compliance and identify an appropriate period of time, as outlined below under environmental deficiency deduction, in which to bring the equipment into compliance or remove it from the project site.

Any costs associated with bringing any diesel powered equipment into compliance with these diesel vehicle emissions controls shall be considered as included in the contract unit prices bid for the various items of work involved and no additional compensation will be allowed. The Contractor's compliance with this notice and any associated regulations shall also not be grounds for a claim.

Environmental Deficiency Deduction. When the Engineer is notified, or determines that an environmental control deficiency exists, he/she will notify the Contractor in writing, and direct the Contractor to correct the deficiency within a specified time period. The specified time-period, which begins upon Contractor notification, will be from 1/2 hour to 24 hours long, based on the urgency of the situation and the nature of the deficiency. The Engineer shall be the sole judge regarding the time period.

The deficiency will be based on lack of repair, maintenance and diesel vehicle emissions control.

If the Contractor fails to correct the deficiency within the specified time frame, a daily monetary deduction will be imposed for each calendar day or fraction thereof the deficiency continues to exist.

The calendar day(s) will begin when the time period for correction is exceeded and end with the Engineer's written acceptance of the correction. The daily monetary deduction will be \$1,000.00 for each deficiency identified.

If a Contractor or subcontractor accumulates three environmental deficiency deductions in a contract period, the Contractor will be shutdown until the deficiency is corrected. Such a shutdown will not be grounds for any extension of contract time, waiver of penalties, or be grounds for any claim.

CONSTRUCTION AIR QUALITY - IDLING RESTRICTIONS (BDE)

Effective: April 1, 2009

Idling Restrictions. The Contractor shall establish truck-staging areas for all diesel powered vehicles that are waiting to load or unload material at the jobsite. Staging areas shall be located where the diesel emissions from the equipment will have a minimum impact on adjacent sensitive receptors. The Department will review the selection of staging areas, whether within or outside the existing highway right-of-way, to avoid locations near sensitive areas or populations to the extent possible. Sensitive receptors include, but are not limited to, hospitals, schools, residences, motels, hotels, daycare facilities, elderly housing and convalescent facilities. Diesel powered engines shall also be located as far away as possible from fresh air intakes, air conditioners, and windows. The Engineer will approve staging areas before implementation.

Diesel powered vehicle operators may not cause or allow the motor vehicle, when it is not in motion, to idle for more than a total of 10 minutes within any 60 minute period, except under any of the following circumstances:

- 1) The motor vehicle has a gross vehicle weight rating of less than 8000 lb (3630 kg).
- 2) The motor vehicle idles while forced to remain motionless because of on-highway traffic, an official traffic control device or signal, or at the direction of a law enforcement official.
- 3) The motor vehicle idles when operating defrosters, heaters, air conditioners, or other equipment solely to prevent a safety or health emergency.
- 4) A police, fire, ambulance, public safety, other emergency or law enforcement motor vehicle, or any motor vehicle used in an emergency capacity, idles while in an emergency or training mode and not for the convenience of the vehicle operator.
- 5) The primary propulsion engine idles for maintenance, servicing, repairing, or diagnostic purposes if idling is necessary for such activity.
- 6) A motor vehicle idles as part of a government inspection to verify that all equipment is in good working order, provided idling is required as part of the inspection.
- 7) When idling of the motor vehicle is required to operate auxiliary equipment to accomplish the intended use of the vehicle (such as loading, unloading, mixing, or processing cargo; controlling cargo temperature; construction operations, lumbering operations; oil or gas well servicing; or farming operations), provided that this exemption does not apply when the vehicle is idling solely for cabin comfort or to operate non-essential equipment such as air conditioning, heating, microwave ovens, or televisions.
- 8) When the motor vehicle idles due to mechanical difficulties over which the operator has no control.
- 9) The outdoor temperature is less than 32 °F (0 °C) or greater than 80 °F (26 °C).

When the outdoor temperature is greater than or equal to 32 °F (0 °C) or less than or equal to 80 °F (26 °C), a person who operates a motor vehicle operating on diesel fuel shall not cause or allow the motor vehicle to idle for a period greater than 30 minutes in any 60 minute period while waiting to weigh, load, or unload cargo or freight, unless the vehicle is in a line of vehicles that regularly and periodically moves forward.

The above requirements do not prohibit the operation of an auxiliary power unit or generator set as an alternative to idling the main engine of a motor vehicle operating on diesel fuel.

Environmental Deficiency Deduction. When the Engineer is notified, or determines that an environmental control deficiency exists based on non-compliance with the idling restrictions, he/she will notify the Contractor, and direct the Contractor to correct the deficiency.

If the Contractor fails to correct the deficiency a monetary deduction will be imposed. The monetary deduction will be \$1,000.00 for each deficiency identified.

DETERMINATION OF THICKNESS (BDE)

Effective: April 1, 2009

Revise Articles 353.12 and 353.13 of the Standard Specifications to Articles 353.13 and 353.14 respectively.

Add the following Article to the Standard Specifications:

“353.12 Tolerance in Thickness. The thickness of base course pay items that individually contain at least 1000 sq yd (840 sq m) of contiguous area, except for temporary construction, bike paths, and individual locations less than 500 ft (150 m) long, will be evaluated. Temporary construction is defined as those areas constructed and removed under the same contract. If the base course cannot be cored for thickness prior to placement of the cover layer(s), the Engineer will determine the thickness of the cover layer(s), and subtract them from the measured core thickness to determine the base course thickness.

The procedure described in Article 407.10(b) will be followed, except the option of correcting deficient pavement with additional lift(s) shall not apply.”

Revise Article 354.09 of the Standard Specifications to read:

“354.09 Tolerance in Thickness. The thickness of base course widening pay items that individually contain at least 1000 sq yd (840 sq m) of contiguous area, except for temporary construction; bike paths and individual locations less than 3 ft (1 m) wide or 1000 ft (300 m) long, will be evaluated. Temporary construction is defined as those areas constructed and removed under the same contract. If the base course widening cannot be cored for thickness prior to placement of the cover layer(s), the Engineer will determine the thickness of the cover layer(s), and subtract them from the measured core thickness to determine the base course widening thickness.

The procedure described in Article 407.10(b) will be followed, except:

- (a) The width of a unit shall be the width of the widening along one edge of the pavement.
- (b) The length of the unit shall be 1000 ft (300 m).
- (c) The option of correcting deficient pavement with additional lift(s) shall not apply.”

Revise Article 355.09 of the Standard Specifications to read:

“**355.09 Tolerance in Thickness.** The thickness of HMA base course pay items that individually contain at least 1000 sq yd (840 sq m) of contiguous area, except for temporary construction; bike paths and individual locations less than 500 ft (150 m) long, will be evaluated according to Article 407.10(b). Temporary construction is defined as those areas constructed and removed under the same contract. If the base course cannot be cored for thickness prior to placement of the cover layer(s), the Engineer will determine the thickness of the cover layer(s), and subtract them from the measured core thickness to determine the base course thickness.”

Revise Article 356.07 of the Standard Specifications to read:

“**356.07 Tolerance in Thickness.** The thickness of HMA base course widening pay items that individually contain at least 1000 sq yd (840 sq m) of contiguous area, except for temporary construction; bike paths and individual locations less than 3 ft (1 m) wide or 1000 ft (300 m) long, will be evaluated according to Article 407.10(b) except, the width of a unit shall be the width of the widening along one edge of the pavement and the length of a unit shall be 1000 ft (300 m). Temporary locations are defined as those constructed and removed under the same contract. If the base course widening cannot be cored for thickness prior to placement of the cover layer(s), the Engineer will determine the thickness of the cover layer(s) and subtract them from the measured core thickness to determine the base course widening thickness.”

Revise Article 407.10 of the Standard Specifications to read:

“**407.10 Tolerance in Thickness.** Determination of pavement thickness shall be performed after the pavement surface tests and corrective action have been completed according to Article 407.09. Pay adjustments made for pavement thickness will be in addition to and independent of those made for pavement smoothness. Pavement pay items that individually contain at least 1000 sq yd (840 sq m) of contiguous pavement shall be evaluated with the following exclusions: temporary pavements; variable width pavements; radius returns; short lengths of contiguous pavements less than 500 ft (125 m) in length; and constant width portions of turn lanes less than 500 ft (125 m) in length. Temporary pavements are defined as pavements constructed and removed under the same contract.

The method described in Article 407.10(a), shall be used except for those pavements constructed in areas where access to side streets and entrances necessitates construction in segments less than 1000 ft (300 m). The method described in Article 407.10(b) shall be used in areas where access to side streets and entrances necessitates construction in segments less than 1000 ft (300 m).

- (a) Percent Within Limits. The percent within limits (PWL) method shall be as follows.

- (1) Lots and Sublots. The pavement will be divided into approximately equal lots of not more than 5000 ft (1500 m) in length.

When the length of a continuous strip of pavement is 500 ft (150 m) or greater but less than 5000 ft (1500 m), these short lengths of pavement, ramps, turn lanes, and other short sections of continuous pavement will be grouped together to form lots approximately 5000 ft (1500 m) in length. Short segments between structures will be measured continuously with the structure segments omitted. Each lot will be subdivided into ten equal sublots. The width of a subplot and lot will be the width from the pavement edge to the adjacent lane line, from one lane line to the next, or between pavement edges for single-lane pavements.

- (2) Cores. Cores 2 in. (50 mm) in diameter shall be taken from the pavement by the Contractor, at locations selected by the Engineer. The exact location for each core will be selected at random, but will result in one core per subplot. Core locations will be specified prior to beginning the coring operations.

The Contractor and the Engineer shall witness the coring operations, as well as the measuring and recording of the core lengths. The cores will be measured with a device supplied by the Department immediately upon removal from the core bit and prior to moving to the next core location. Upon concurrence of the length, the core samples shall be disposed of according to Article 202.03.

Upon completion of each core, all water shall be removed from the hole and the hole then filled with a rapid hardening mortar or concrete. The material shall be mixed in a separate container, placed in the hole, consolidated by rodding, and struck-off flush with the adjacent pavement.

- (3) Deficient Sublot. When the length of the core in a subplot is deficient by more than ten percent of plan thickness, the Contractor may take three additional cores within that subplot at locations selected at random by the Engineer. If the Contractor chooses not to take additional cores, the pavement in that subplot shall be removed and replaced.

When the three additional cores are taken, the length of those cores will be averaged with the original core length. If the average shows the subplot to be deficient by ten percent or less, no additional action is necessary. If the average shows the subplot to be deficient by more than ten percent, the pavement in that subplot shall be removed and replaced; however, when requested in writing by the Contractor, the Engineer may permit in writing such deficient sublots to remain in place. For deficient sublots allowed to remain in place, additional lift(s) may be placed, at no additional cost to the Department, to bring the deficient pavement to plan thickness when the Engineer determines grade control conditions will permit such lift(s). The area(s) to be overlaid, material to be used, thickness(es) of the lift(s), and method of placement will be approved by the Engineer.

When a deficient subplot is removed and replaced, or additional lifts are placed, the corrected subplot shall be retested for thickness. The length of the new core taken in the subplot will be used in determining the PWL for the lot.

When a deficient subplot is left in place, and no additional lift(s) are placed, no payment will be made for the deficient subplot. The length of the original core taken in the subplot will be used in determining the PWL for the lot.

- (4) Deficient Lot. After addressing deficient sublots, the PWL for each lot will be determined. When the PWL of a lot is 60 percent or less, the pavement in that lot shall be removed and replaced; however, when requested in writing by the Contractor, the Engineer may permit in writing such deficient lots to remain in place. For deficient lots allowed to remain in place, additional lift(s) may be placed, at no additional cost to the Department, to bring the deficient pavement to plan thickness when the Engineer determines grade control conditions will permit such lift(s). The area(s) to be overlaid, material to be used, thickness(es) of the lift(s), and method of placement will be approved by the Engineer.

When a deficient lot is removed and replaced, or additional lifts are placed, the corrected lot shall be retested for thickness. The PWL for the lot will then be recalculated based upon the new cores; however, the pay factor for the lot shall be a maximum of 100 percent.

When a deficient lot is left in place, and no additional lift(s) are placed, the PWL for the lot will not be recalculated.

- (5) Right of Discovery. When the Engineer has reason to believe the random core selection process will not accurately represent the true conditions of the work, he/she may order additional cores. The additional cores shall be taken at specific locations determined by the Engineer. The Engineer will provide notice to the Contractor containing an explanation of the reasons for his/her action. The need for, and location of, additional cores will be determined prior to commencement of coring operations.

When the additional cores show the pavement to be deficient by more than ten percent of plan thickness, more additional cores shall be taken to determine the limits of the deficient pavement and that area shall be removed and replaced; however, when requested in writing by the Contractor, the Engineer may permit in writing such areas of deficient pavement to remain in place. The area of deficient pavement will be defined using the length between two acceptable cores and the full width of the sublot. An acceptable core is a core with a length of at least 90 percent of plan thickness.

For deficient areas allowed to remain in place, additional lift(s) may be placed, at no additional cost to the Department, to bring the deficient pavement to plan thickness when the Engineer determines grade control conditions will permit such lift(s). The area(s) to be overlaid, material to be used, thickness(es) of the lift(s), and method of placement will be approved by the Engineer.

When an area of deficient pavement is removed and replaced, or additional lifts are placed, the corrected pavement shall be retested for thickness.

When an area of deficient pavement is left in place, and no additional lift(s) are placed, no payment will be made for the deficient pavement.

When the additional cores show the pavement to be at least 90 percent of plan thickness, the additional cores will be paid for according to Article 109.04.

(6) Profile Index Adjustment. After any area of pavement is removed and replaced or any additional lifts are placed, the corrected areas shall be retested for pavement smoothness and any necessary profile index adjustments and/or corrections will be made based on these final profile readings prior to retesting for thickness.

(7) Determination of PWL. The PWL for each lot will be determined as follows.

Definitions:

- x_i = Individual values (core lengths) under consideration
- n = Number of individual values under consideration (10 per lot)
- \bar{x} = Average of the values under consideration
- LSL = Lower Specification Limit (98% of plan thickness)
- Q_L = Lower Quality Index
- s = Sample Standard Deviation
- PWL = Percent Within Limits

Determine \bar{x} for the lot to the nearest two decimal places.

Determine s for the lot to the nearest three decimal places using:

$$s = \sqrt{\frac{\sum(x_i - \bar{x})^2}{n-1}} \quad \text{where} \quad \sum(x_i - \bar{x})^2 = (x_1 - \bar{x})^2 + (x_2 - \bar{x})^2 + \dots + (x_{10} - \bar{x})^2$$

Determine Q_L for the lot to the nearest two decimal places using:

$$Q_L = \frac{(\bar{x} - LSL)}{s}$$

Determine PWL for the lot using the Q_L and the following table. For Q_L values less than zero the value shown in the table must be subtracted from 100 to obtain PWL.

(8) Pay Factors. The pay factor (PF) for each lot will be determined, to the nearest two decimal places, using:

$$PF \text{ (in percent)} = 55 + 0.5 (PWL)$$

If \bar{x} for a lot is less than the plan thickness, the maximum PF for that lot shall be 100 percent.

(9) Payment. Payment of incentive or disincentive for pay items subject to the PWL method will be calculated using:

$$\text{Payment} = (((TPF/100)-1) \times CUP) \times (\text{TOTPAVT} - \text{DEFPAVT})$$

- TPF = Total Pay Factor
- CUP = Contract Unit Price
- TOTPAVT = Area of Pavement Subject to Coring
- DEFPAVT = Area of Deficient Pavement

The TPF for the pavement shall be the average of the PF for all the lots; however, the TPF shall not exceed 102 percent.

Area of Deficient pavement (DEFPAVT) is defined as an area of pavement represented by a subplot deficient by more than ten percent which is left in place with no additional thickness added.

Area of Pavement Subject to Coring (TOTPAVT) is defined as those pavement areas included in lots for pavement thickness determination.

PERCENT WITHIN LIMITS							
Quality Index (Q _L)*	Percent Within Limits (PWL)	Quality Index (Q _L)*	Percent Within Limits (PWL)	Quality Index (Q _L)*	Percent Within Limits (PWL)	Quality Index (Q _L)*	Percent Within Limits (PWL)
0.00	50.00	0.40	65.07	0.80	78.43	1.20	88.76
0.01	50.38	0.41	65.43	0.81	78.72	1.21	88.97
0.02	50.77	0.42	65.79	0.82	79.02	1.22	89.17
0.03	51.15	0.43	66.15	0.83	79.31	1.23	89.38
0.04	51.54	0.44	66.51	0.84	79.61	1.24	89.58
0.05	51.92	0.45	66.87	0.85	79.90	1.25	89.79
0.06	52.30	0.46	67.22	0.86	80.19	1.26	89.99
0.07	52.69	0.47	67.57	0.87	80.47	1.27	90.19
0.08	53.07	0.48	67.93	0.88	80.76	1.28	90.38
0.09	53.46	0.49	68.28	0.89	81.04	1.29	90.58
0.10	53.84	0.50	68.63	0.90	81.33	1.30	90.78
0.11	54.22	0.51	68.98	0.91	81.61	1.31	90.96
0.12	54.60	0.52	69.32	0.92	81.88	1.32	91.15
0.13	54.99	0.53	69.67	0.93	82.16	1.33	91.33
0.14	55.37	0.54	70.01	0.94	82.43	1.34	91.52
0.15	55.75	0.55	70.36	0.95	82.71	1.35	91.70
0.16	56.13	0.56	70.70	0.96	82.97	1.36	91.87
0.17	56.51	0.57	71.04	0.97	83.24	1.37	92.04
0.18	56.89	0.58	71.38	0.98	83.50	1.38	92.22
0.19	57.27	0.59	71.72	0.99	83.77	1.39	92.39
0.20	57.65	0.60	72.06	1.00	84.03	1.40	92.56
0.21	58.03	0.61	72.39	1.01	84.28	1.41	92.72
0.22	58.40	0.62	72.72	1.02	84.53	1.42	92.88
0.23	58.78	0.63	73.06	1.03	84.79	1.43	93.05
0.24	59.15	0.64	73.39	1.04	85.04	1.44	93.21
0.25	59.53	0.65	73.72	1.05	85.29	1.45	93.37
0.26	59.90	0.66	74.04	1.06	85.53	1.46	93.52
0.27	60.28	0.67	74.36	1.07	85.77	1.47	93.67
0.28	60.65	0.68	74.69	1.08	86.02	1.48	93.83
0.29	61.03	0.69	75.01	1.09	86.26	1.49	93.98
0.30	61.40	0.70	75.33	1.10	86.50	1.50	94.13
0.31	61.77	0.71	75.64	1.11	86.73	1.51	94.27
0.32	62.14	0.72	75.96	1.12	86.96	1.52	94.41
0.33	62.51	0.73	76.27	1.13	87.20	1.53	94.54
0.34	62.88	0.74	76.59	1.14	87.43	1.54	94.68
0.35	63.25	0.75	76.90	1.15	87.66	1.55	94.82
0.36	63.61	0.76	77.21	1.16	87.88	1.56	94.95
0.37	63.98	0.77	77.51	1.17	88.10	1.57	95.08
0.38	64.34	0.78	77.82	1.18	88.32	1.58	95.20
0.39	64.71	0.79	78.12	1.19	88.54	1.59	95.33

*For Q_L values less than zero, subtract the table value from 100 to obtain PWL

PERCENT WITHIN LIMITS (continued)					
Quality Index (Q _L)*	Percent Within Limits (PWL)	Quality Index (Q _L)*	Percent Within Limits (PWL)	Quality Index (Q _L)*	Percent Within Limits (PWL)
1.60	95.46	2.00	98.83	2.40	99.89
1.61	95.58	2.01	98.88	2.41	99.90
1.62	95.70	2.02	98.92	2.42	99.91
1.63	95.81	2.03	98.97	2.43	99.91
1.64	95.93	2.04	99.01	2.44	99.92
1.65	96.05	2.05	99.06	2.45	99.93
1.66	96.16	2.06	99.10	2.46	99.94
1.67	96.27	2.07	99.14	2.47	99.94
1.68	96.37	2.08	99.18	2.48	99.95
1.69	96.48	2.09	99.22	2.49	99.95
1.70	96.59	2.10	99.26	2.50	99.96
1.71	96.69	2.11	99.29	2.51	99.96
1.72	96.78	2.12	99.32	2.52	99.97
1.73	96.88	2.13	99.36	2.53	99.97
1.74	96.97	2.14	99.39	2.54	99.98
1.75	97.07	2.15	99.42	2.55	99.98
1.76	97.16	2.16	99.45	2.56	99.98
1.77	97.25	2.17	99.48	2.57	99.98
1.78	97.33	2.18	99.50	2.58	99.99
1.79	97.42	2.19	99.53	2.59	99.99
1.80	97.51	2.20	99.56	2.60	99.99
1.81	97.59	2.21	99.58	2.61	99.99
1.82	97.67	2.22	99.61	2.62	99.99
1.83	97.75	2.23	99.63	2.63	100.00
1.84	97.83	2.22	99.66	2.64	100.00
1.85	97.91	2.25	99.68	≥ 2.65	100.00
1.86	97.98	2.26	99.70		
1.87	98.05	2.27	99.72		
1.88	98.11	2.28	99.73		
1.89	98.18	2.29	99.75		
1.90	98.25	2.30	99.77		
1.91	98.31	2.31	99.78		
1.92	98.37	2.32	99.80		
1.93	98.44	2.33	99.81		
1.94	98.50	2.34	99.83		
1.95	98.56	2.35	99.84		
1.96	98.61	2.36	99.85		
1.97	98.67	2.37	99.86		
1.98	98.72	2.38	99.87		
1.99	98.78	2.39	99.88		

*For Q_L values less than zero, subtract the table value from 100 to obtain PWL

(b) Minimum Thickness. The minimum thickness method shall be as follows.

(1) Length of Units. The length of a unit will be a continuous strip of pavement 500 ft (150 m) in length.

- (2) Width of Units. The width of a unit will be the width from the pavement edge to the adjacent lane line, from one lane line to the next, or between pavement edges for single-lane pavements.
- (3) Thickness Measurements. Pavement thickness will be based on 2 in. (50 mm) diameter cores.

Cores shall be taken from the pavement by the Contractor at locations selected by the Engineer. When determining the thickness of a unit, one core shall be taken in each unit.

The Contractor and the Engineer shall witness the coring operations, as well as the measuring and recording of the cores. Core measurements will be determined immediately upon removal from the core bit and prior to moving to the next core location. Upon concurrence of the length, the core samples may be disposed of according to Article 202.03.

Upon completion of each core, all water shall be removed from the hole and the hole then filled with a rapid hardening mortar or concrete. The material shall be mixed in a separate container, placed in the hole, consolidated by rodding, and struck-off flush with the adjacent pavement.

- (4) Unit Deficient in Thickness. In considering any portion of the pavement that is deficient, the entire limits of the unit will be used in computing the deficiency or determining the remedial action required.
- (5) Thickness Equals or Exceeds Specified Thickness. When the thickness of a unit equals or exceeds the specified plan thickness, payment will be made at the contract unit price per square yard (square meter) for the specified thickness.
- (6) Thickness Deficient by Ten Percent or Less. When the thickness of a unit is less than the specified plan thickness by ten percent or less, a deficiency deduction will be assessed against payment for the item involved. The deficiency will be a percentage of the contract unit price as given in the following table.

Percent Deficiency (of Plan Thickness)	Percent Deduction (of Contract Unit Price)
0.0 to 2.0	0
2.1 to 3.0	20
3.1 to 4.0	28
4.1 to 5.0	32
5.1 to 7.5	43
7.6 to 10.0	50

- (7) Thickness Deficient by More than Ten Percent. When a core shows the pavement to be deficient by more than ten percent of plan thickness, additional cores shall be taken on each side of the deficient core, at stations selected by the Contractor and offsets selected by the Engineer, to determine the limits of the deficient pavement.

No core shall be located within 5 ft (1.5 m) of a previous core obtained for thickness determination. The first acceptable core obtained on each side of a deficient core will be used to determine the length of the deficient pavement. An acceptable core is a core with a thickness of at least 90 percent of plan thickness. The area of deficient pavement will be defined using the length between two acceptable cores and the full width of the unit. The area of deficient pavement shall be removed and replaced; however, when requested in writing by the Contractor, the Engineer may permit in writing such areas of deficient pavement to remain in place. For deficient areas allowed to remain in place, additional lift(s) may be placed, at no additional cost to the Department, to bring the deficient pavement to plan thickness when the Engineer determines grade control conditions will permit such lift(s). The area(s) to be overlaid, material to be used, thickness(es) of the lift(s), and method of placement will be approved by the Engineer.

When an area of deficient pavement is removed and replaced, or additional lifts are placed, the corrected pavement shall be retested for thickness. The thickness of the new core will be used to determine the pay factor for the corrected area.

When an area of deficient pavement is left in place, and no additional lift(s) are placed, no payment will be made for the deficient pavement. In addition, an amount equal to two times the contract cost of the deficient pavement will be deducted from the compensation due the Contractor.

The thickness of the first acceptable core on each side of the core more than ten percent deficient will be used to determine any needed pay adjustments for the remaining areas on each side of the area deficient by more than ten percent. The pay adjustment will be determined according to Article 407.10(b)(6).

- (8) Right of Discovery. When the Engineer has reason to believe any core location does not accurately represent the true conditions of the work, he/she may order additional cores. These additional cores shall be taken at specific locations determined by the Engineer. The Engineer will provide notice to the Contractor containing an explanation of the reasons for his/her action.

When the additional cores show the pavement to be deficient by more than ten percent of plan thickness, the procedures outlined in Article 407.10(b)(7) shall be followed, except the Engineer will determine the additional core locations.

When the additional cores, ordered by the Engineer, show the pavement to be at least 90 percent of plan thickness, the additional cores will be paid for according to Article 109.04.

- (9) Profile Index Adjustment. After any area of pavement is removed and replaced or any additional lifts are added, the corrected areas shall be retested for pavement smoothness and any necessary profile index adjustments and/or corrections will be made based on these final profile readings prior to retesting for thickness.”

Revise Article 482.06 of the Standard Specifications to read:

“482.06 Tolerance in Thickness. The shoulder shall be constructed to the thickness shown on the plans. When the contract includes square yards (square meters) as the unit of measurement for HMA shoulder, thickness determinations shall be made according to Article 407.10(b)(3) and the following.

- (a) Length of the Units. The length of a unit shall be a continuous strip of shoulder 2500 ft (750 m) long.
- (b) Width of the Units. The width of the unit shall be the full width of the shoulder.
- (c) Thickness Deficient by More than Ten Percent. When a core shows the shoulder to be deficient by more than ten percent of plan thickness, additional cores shall be taken on each side of the deficient core, at stations selected by the Contractor and offsets selected by the Engineer, to determine the limits of the deficient shoulder. No core shall be located within 5 ft (1.5 m) of a previous core obtained for thickness determination. The first acceptable core obtained on each side of a deficient core will be used to determine the length of the deficient shoulder. An acceptable core is a core with a thickness of at least 90 percent of plan thickness. The area of deficient shoulder will be defined using the length between two acceptable cores and the full width of the unit. The area of deficient shoulder shall be brought to specified thickness by the addition of the applicable mixture, at no additional cost to the Department and subject to the lift thickness requirements of Article 312.05, or by removal and replacement with a new mixture. However, the surface elevation of the completed shoulder shall not exceed by more than 1/8 in. (3 mm) the surface elevation of the adjacent pavement. When requested in writing by the Contractor, the Engineer may permit in writing such thin shoulder to remain in place. When an area of thin shoulder is left in place, and no additional lift(s) are placed, no payment will be made for the thin shoulder. In addition, an amount equal to two times the contract unit price of the shoulder will be deducted from the compensation due the Contractor.

When an area of deficient shoulder is removed and replaced, or additional lifts are placed, the corrected pavement shall be retested for thickness.

- (d) Right of Discovery. When the Engineer has reason to believe any core location does not accurately represent the true conditions of the work, he/she may order additional cores. When the additional cores, ordered by the Engineer, show the shoulder to be at least 90 percent of plan thickness, the additional cores will be paid for according to Article 109.04. When the additional core shows the shoulder to be less than 90 percent of plan thickness, the procedure in (c), above shall be followed.”

Revise Article 483.07 of the Standard Specifications to read:

“483.07 Tolerance in Thickness. The shoulder shall be constructed to the thickness shown on the plans. Thickness determinations shall be made according to Article 482.06 except the option of correcting deficient pavement with additional lift(s) shall not apply.”

DISADVANTAGED BUSINESS ENTERPRISE PARTICIPATION (DBE)

Effective: September 1, 2000

Revised: January 1, 2010

FEDERAL OBLIGATION. The Department of Transportation, as a recipient of federal financial assistance, is required to take all necessary and reasonable steps to ensure nondiscrimination in the award and administration of contracts. Consequently, the federal regulatory provisions of 49 CFR part 26 apply to this contract concerning the utilization of disadvantaged business enterprises. For the purposes of this Special Provision, a disadvantaged business enterprise (DBE) means a business certified by the Department in accordance with the requirements of 49 CFR part 26 and listed in the Illinois Unified Certification Program (IL UCP) DBE Directory.

STATE OBLIGATION. This Special Provision will also be used by the Department to satisfy the requirements of the Business Enterprise for Minorities, Females, and Persons with Disabilities Act, 30 ILCS 575. When this Special Provision is used to satisfy state law requirements on 100 percent state-funded contracts, the federal government has no involvement in such contracts (not a federal-aid contract) and no responsibility to oversee the implementation of this Special Provision by the Department on those contracts. DBE participation on 100 percent state-funded contracts will not be credited toward fulfilling the Department's annual overall DBE goal required by the US Department of Transportation to comply with the federal DBE program requirements.

CONTRACTOR ASSURANCE. The Contractor makes the following assurance and agrees to include the assurance in each subcontract that the Contractor signs with a subcontractor:

The Contractor, subrecipient, or subcontractor shall not discriminate on the basis of race, color, national origin, or sex in the performance of this contract. The Contractor shall carry out applicable requirements of 49 CFR part 26 in the award and administration of contracts funded in whole or in part with federal or state funds. Failure by the Contractor to carry out these requirements is a material breach of this contract, which may result in the termination of this contract or such other remedy as the recipient deems appropriate.

OVERALL GOAL SET FOR THE DEPARTMENT. As a requirement of compliance with 49 CFR part 26, the Department has set an overall goal for DBE participation in its federally assisted contracts. That goal applies to all federal-aid funds the Department will expend in its federally assisted contracts for the subject reporting fiscal year. The Department is required to make a good faith effort to achieve the overall goal. The dollar amount paid to all approved DBE companies performing work called for in this contract is eligible to be credited toward fulfillment of the Department's overall goal.

CONTRACT GOAL TO BE ACHIEVED BY THE CONTRACTOR. This contract includes a specific DBE utilization goal established by the Department. The goal has been included because the Department has determined that the work of this contract has subcontracting opportunities that may be suitable for performance by DBE companies. This determination is based on an assessment of the type of work, the location of the work, and the availability of DBE companies to do a part of the work. The assessment indicates that, in the absence of unlawful discrimination, and in an arena of fair and open competition, DBE companies can be expected to perform **4.0%** of the work. This percentage is set as the DBE participation goal for this contract. Consequently, in addition to the other award criteria established for this contract, the Department will only award this contract to a bidder who makes a good faith effort to meet this goal of DBE participation in the performance of the work.

A bidder makes a good faith effort for award consideration if either of the following is done in accordance with the procedures set forth in this Special Provision:

- (a) The bidder documents that enough DBE participation has been obtained to meet the goal; or
- (b) The bidder documents that a good faith effort has been made to meet the goal, even though the effort did not succeed in obtaining enough DBE participation to meet the goal.

DBE LOCATOR REFERENCES. Bidders may consult the IL UCP DBE Directory as a reference source for DBE-certified companies. In addition, the Department maintains a letting and item specific DBE locator information system whereby DBE companies can register their interest in providing quotes on particular bid items advertised for letting. Information concerning DBE companies willing to quote work for particular contracts may be obtained by contacting the Department's Bureau of Small Business Enterprises at telephone number (217)785-4611, or by visiting the Department's web site at www.dot.il.gov.

BIDDING PROCEDURES. Compliance with this Special Provision is a material bidding requirement. The failure of the bidder to comply will render the bid not responsive.

(a) The bidder shall submit a Disadvantaged Business Utilization Plan on Department forms SBE 2025 and 2026 with the bid.

(b) The Utilization Plan shall indicate that the bidder either has obtained sufficient DBE participation commitments to meet the contract goal or has not obtained enough DBE participation commitments in spite of a good faith effort to meet the goal. The Utilization Plan shall further provide the name, telephone number, and telefax number of a responsible official of the bidder designated for purposes of notification of plan approval or disapproval under the procedures of this Special Provision.

(c) The Utilization Plan shall include a DBE Participation Commitment Statement, Department form SBE 2025, for each DBE proposed for the performance of work to achieve the contract goal. For bidding purposes, submission of the completed SBE 2025 forms, signed by the DBEs and faxed to the bidder will be acceptable as long as the original is available and provided upon request. All elements of information indicated on the said form shall be provided, including but not limited to the following:

(1) The names and addresses of DBE firms that will participate in the contract;

(2) A description, including pay item numbers, of the work each DBE will perform;

(3) The dollar amount of the participation of each DBE firm participating. The dollar amount of participation for identified work shall specifically state the quantity, unit price, and total subcontract price for the work to be completed by the DBE. If partial pay items are to be performed by the DBE, indicate the portion of each item, a unit price where appropriate and the subcontract price amount;

(4) DBE Participation Commitment Statements, form SBE 2025, signed by the bidder and each participating DBE firm documenting the commitment to use the DBE subcontractors whose participation is submitted to meet the contract goal;

- (5) If the bidder is a joint venture comprised of DBE companies and non-DBE companies, the plan must also include a clear identification of the portion of the work to be performed by the DBE partner(s); and,
- (6) If the contract goal is not met, evidence of good faith efforts.

GOOD FAITH EFFORT PROCEDURES. The contract will not be awarded until the Utilization Plan submitted by the apparent successful bidder is approved. All information submitted by the bidder must be complete, accurate and adequately document the good faith efforts of the bidder before the Department will commit to the performance of the contract by the bidder. The Utilization Plan will be approved by the Department if the Utilization Plan commits sufficient commercially useful DBE work performance to meet the contract goal or the bidder submits sufficient documentation of a good faith effort to meet the contract goal pursuant to 49 CFR part 26, Appendix A. The Utilization Plan will not be approved by the Department if the Utilization Plan does not commit sufficient DBE participation to meet the contract goal unless the apparent successful bidder documented in the Utilization Plan that it made a good faith effort to meet the goal. This means that the bidder must show that all necessary and reasonable steps were taken to achieve the contract goal. Necessary and reasonable steps are those which, by their scope, intensity and appropriateness to the objective, could reasonably be expected to obtain sufficient DBE participation, even if they were not successful. The Department will consider the quality, quantity, and intensity of the kinds of efforts that the bidder has made. Mere *pro forma* efforts, in other words, efforts done as a matter of form, are not good faith efforts; rather, the bidder is expected to have taken genuine efforts that would be reasonably expected of a bidder actively and aggressively trying to obtain DBE participation sufficient to meet the contract goal.

(a) The following is a list of types of action that the Department will consider as part of the evaluation of the bidder's good faith efforts to obtain participation. These listed factors are not intended to be a mandatory checklist and are not intended to be exhaustive. Other factors or efforts brought to the attention of the Department may be relevant in appropriate cases, and will be considered by the Department.

(1) Soliciting through all reasonable and available means (e.g. attendance at pre-bid meetings, advertising and/or written notices) the interest of all certified DBE companies that have the capability to perform the work of the contract. The bidder must solicit this interest within sufficient time to allow the DBE companies to respond to the solicitation. The bidder must determine with certainty if the DBE companies are interested by taking appropriate steps to follow up initial solicitations.

(2) Selecting portions of the work to be performed by DBE companies in order to increase the likelihood that the DBE goals will be achieved. This includes, where appropriate, breaking out contract work items into economically feasible units to facilitate DBE participation, even when the prime Contractor might otherwise prefer to perform these work items with its own forces.

(3) Providing interested DBE companies with adequate information about the plans, specifications, and requirements of the contract in a timely manner to assist them in responding to a solicitation.

(4) a. Negotiating in good faith with interested DBE companies. It is the bidder's responsibility to make a portion of the work available to DBE subcontractors and suppliers and to select those portions of the work or material needs consistent with the available DBE subcontractors and suppliers, so as to facilitate DBE participation. Evidence of such negotiation includes the names, addresses, and telephone numbers of DBE companies that were considered; a description of the information provided regarding the plans and specifications for the work selected for subcontracting; and evidence as to why additional agreements could not be reached for DBE companies to perform the work.

b. A bidder using good business judgment would consider a number of factors in negotiating with subcontractors, including DBE subcontractors, and would take a firm's price and capabilities as well as contract goals into consideration. However, the fact that there may be some additional costs involved in finding and using DBE companies is not in itself sufficient reason for a bidder's failure to meet the contract DBE goal, as long as such costs are reasonable. Also, the ability or desire of a bidder to perform the work of a contract with its own organization does not relieve the bidder of the responsibility to make good faith efforts. Bidders are not, however, required to accept higher quotes from DBE companies if the price difference is excessive or unreasonable.

(5) Not rejecting DBE companies as being unqualified without sound reasons based on a thorough investigation of their capabilities. The bidder's standing within its industry, membership in specific groups, organizations, or associations and political or social affiliations (for example union vs. non-union employee status) are not legitimate causes for the rejection or non-solicitation of bids in the bidder's efforts to meet the project goal.

(6) Making efforts to assist interested DBE companies in obtaining bonding, lines of credit, or insurance as required by the recipient or Contractor.

(7) Making efforts to assist interested DBE companies in obtaining necessary equipment, supplies, materials, or related assistance or services.

(8) Effectively using the services of available minority/women community organizations; minority/women contractors' groups; local, state, and federal minority/women business assistance offices; and other organizations as allowed on a case-by-case basis to provide assistance in the recruitment and placement of DBE companies.

(b) If the Department determines that the apparent successful bidder has made a good faith effort to secure the work commitment of DBE companies to meet the contract goal, the Department will award the contract provided that it is otherwise eligible for award. If the Department determines that the bidder has failed to meet the requirements of this Special Provision and that a good faith effort has not been made, the Department will notify the responsible company official designated in the Utilization Plan that the bid is not responsive. The notification shall include a statement of reasons why good faith efforts have not been found.

(c) The bidder may request administrative reconsideration of a determination adverse to the bidder within the five working days after receipt of the notification date of the determination by delivering the request to the Department of Transportation, Bureau of Small Business Enterprises, Contract Compliance Section, 2300 South Dirksen Parkway, Room 319, Springfield, Illinois 62764 (Telefax: (217)785-1524).

Deposit of the request in the United States mail on or before the fifth business day shall not be deemed delivery. The determination shall become final if a request is not made and delivered. A request may provide additional written documentation and/or argument concerning the issue of whether an adequate good faith effort was made to meet the contract goal. The request will be forwarded to the Department's Reconsideration Officer. The Reconsideration Officer will extend an opportunity to the bidder to meet in person in order to consider all issues of whether the bidder made a good faith effort to meet the goal. After the review by the Reconsideration Officer, the bidder will be sent a written decision within ten working days after receipt of the request for reconsideration, explaining the basis for finding that the bidder did or did not meet the goal or make adequate good faith efforts to do so. A final decision by the Reconsideration Officer that a good faith effort was made shall approve the Utilization Plan submitted by the bidder and shall clear the contract for award. A final decision that a good faith effort was not made shall render the bid not responsive.

CALCULATING DBE PARTICIPATION. The Utilization Plan values represent work anticipated to be performed and paid for upon satisfactory completion. The Department is only able to count toward the achievement of the overall goal and the contract goal the value of payments made for the work actually performed by DBE companies. In addition, a DBE must perform a commercially useful function on the contract to be counted. A commercially useful function is generally performed when the DBE is responsible for the work and is carrying out its responsibilities by actually performing, managing, and supervising the work involved. The Department and Contractor are governed by the provisions of 49 CFR part 26.55(c) on questions of commercially useful functions as it affects the work. Specific counting guidelines are provided in 49 CFR part 26.55, the provisions of which govern over the summary contained herein.

(a) DBE as the Contractor: 100 percent goal credit for that portion of the work performed by the DBE's own forces, including the cost of materials and supplies. Work that a DBE subcontracts to a non-DBE does not count toward the DBE goals.

(b) DBE as a joint venture Contractor: 100 percent goal credit for that portion of the total dollar value of the contract equal to the distinct, clearly defined portion of the work performed by the DBE's own forces.

(c) DBE as a subcontractor: 100 percent goal credit for the work of the subcontract performed by the DBE's own forces, including the cost of materials and supplies, excluding the purchase of materials and supplies or the lease of equipment by the DBE subcontractor from the prime Contractor or its affiliates. Work that a DBE subcontractor in turn subcontracts to a non-DBE does not count toward the DBE goal.

(d) DBE as a trucker: 100 percent goal credit for trucking participation provided the DBE is responsible for the management and supervision of the entire trucking operation for which it is responsible. At least one truck owned, operated, licensed, and insured by the DBE must be used on the contract. Credit will be given for the following:

(1) The DBE may lease trucks from another DBE firm, including an owner-operator who is certified as a DBE. The DBE who leases trucks from another DBE receives credit for the total value of the transportation services the lessee DBE provides on the contract.

- (2) The DBE may also lease trucks from a non-DBE firm, including from an owner-operator. The DBE who leases trucks from a non-DBE is entitled to credit only for the fee or commission it receives as a result of the lease arrangement.
- (e) DBE as a material supplier:
 - (1) 60 percent goal credit for the cost of the materials or supplies purchased from a DBE regular dealer.
 - (2) 100 percent goal credit for the cost of materials or supplies obtained from a DBE manufacturer.
 - (3) 100 percent credit for the value of reasonable fees and commissions for the procurement of materials and supplies if not a regular dealer or manufacturer.

CONTRACT COMPLIANCE. Compliance with this Special Provision is an essential part of the contract. The Department is prohibited by federal regulations from crediting the participation of a DBE included in the Utilization Plan toward either the contract goal or the Department's overall goal until the amount to be applied toward the goals has been paid to the DBE. The following administrative procedures and remedies govern the compliance by the Contractor with the contractual obligations established by the Utilization Plan. After approval of the Utilization Plan and award of the contract, the Utilization Plan and individual DBE Participation Statements become part of the contract. If the Contractor did not succeed in obtaining enough DBE participation to achieve the advertised contract goal, and the Utilization Plan was approved and contract awarded based upon a determination of good faith, the total dollar value of DBE work calculated in the approved Utilization Plan as a percentage of the awarded contract value shall become the amended contract goal.

- (a) No amendment to the Utilization Plan may be made without prior written approval from the Department's Bureau of Small Business Enterprises. All requests for amendment to the Utilization Plan shall be submitted to the Department of Transportation, Bureau of Small Business Enterprises, Contract Compliance Section, 2300 South Dirksen Parkway, Room 319, Springfield, Illinois 62764. Telephone number (217) 785-4611. Telefax number (217) 785-1524.
- (b) The Contractor must notify and obtain written approval from the Department's Bureau of Small Business Enterprises prior to replacing a DBE or making any change in the participation of a DBE. Approval for replacement will be granted only if it is demonstrated that the DBE is unable or unwilling to perform. The Contractor must make every good faith effort to find another certified DBE subcontractor to substitute for the original DBE. The good faith efforts shall be directed at finding another DBE to perform at least the same amount of work under the contract as the original DBE, to the extent needed to meet the contract goal.
- (c) Any deviation from the DBE condition-of-award or contract specifications must be approved, in writing, by the Department. The Contractor shall notify affected DBEs in writing of any changes in the scope of work which result in a reduction in the dollar amount condition-of-award to the contract.
- (d) In addition to the above requirements for reductions in the condition of award, additional requirements apply to the two cases of Contractor-initiated work substitution proposals.

Where the contract allows alternate work methods which serve to delete or create underruns in condition of award DBE work, and the Contractor selects that alternate method or, where the Contractor proposes a substitute work method or material that serves to diminish or delete work committed to a DBE and replace it with other work, then the Contractor must demonstrate one of the following:

- (1) That the replacement work will be performed by the same DBE (as long as the DBE is certified in the respective item of work) in a modification of the condition of award; or
- (2) That the DBE is aware that its work will be deleted or will experience underruns and has agreed in writing to the change. If this occurs, the Contractor shall substitute other work of equivalent value to a certified DBE or provide documentation of good faith efforts to do so; or
- (3) That the DBE is not capable of performing the replacement work or has declined to perform the work at a reasonably competitive price. If this occurs, the Contractor shall substitute other work of equivalent value to a certified DBE or provide documentation of good faith efforts to do so.

(e) Where the revision includes work committed to a new DBE subcontractor, not previously involved in the project, then a Request for Approval of Subcontractor, Department form BC 260A, must be signed and submitted.

(f) If the commitment of work is in the form of additional tasks assigned to an existing subcontract, then a new Request for Approval of Subcontractor shall not be required. However, the Contractor must document efforts to assure that the existing DBE subcontractor is capable of performing the additional work and has agreed in writing to the change.

(g) All work indicated for performance by an approved DBE shall be performed, managed, and supervised by the DBE executing the Participation Statement. The Contractor shall not terminate for convenience a DBE listed in the Utilization Plan and then perform the work of the terminated DBE with its own forces, those of an affiliate or those of another subcontractor, whether DBE or not, without first obtaining the written consent of the Bureau of Small Business Enterprises to amend the Utilization Plan. The Contractor shall notify the Bureau of Small Business Enterprises of any termination for reasons other than convenience, and shall obtain approval for inclusion of the substitute DBE in the Utilization Plan. If good faith efforts following a termination of a DBE for cause are not successful, the Contractor shall contact the Bureau of Small Business Enterprises and provide a full accounting of the efforts undertaken to obtain substitute DBE participation. The Bureau of Small Business Enterprises will evaluate the good faith efforts in light of all circumstances surrounding the performance status of the contract, and determine whether the contract goal should be amended.

(h) The Contractor shall maintain a record of payments for work performed to the DBE participants. The records shall be made available to the Department for inspection upon request. After the performance of the final item of work or delivery of material by a DBE and final payment therefore to the DBE by the Contractor, but not later than thirty calendar days after payment has been made by the Department to the Contractor for such work or material, the Contractor shall submit a DBE Payment Agreement on Department form SBE 2115 to the Regional Engineer.

If full and final payment has not been made to the DBE, the DBE Payment Agreement shall indicate whether a disagreement as to the payment required exists between the Contractor and the DBE or if the Contractor believes that the work has not been satisfactorily completed. If the Contractor does not have the full amount of work indicated in the Utilization Plan performed by the DBE companies indicated in the Utilization Plan and after good faith efforts are reviewed, the Department may deduct from contract payments to the Contractor the amount of the goal not achieved as liquidated and ascertained damages. The Contractor may request an administrative reconsideration of any amount deducted as damages pursuant to subsection (j) of this part.

(i) The Department reserves the right to withhold payment to the Contractor to enforce the provisions of this Special Provision. Final payment shall not be made on the contract until such time as the Contractor submits sufficient documentation demonstrating achievement of the goal in accordance with this Special Provision or after liquidated damages have been determined and collected.

(j) Notwithstanding any other provision of the contract, including but not limited to Article 109.09 of the Standard Specifications, the Contractor may request administrative reconsideration of a decision to deduct the amount of the goal not achieved as liquidated damages. A request to reconsider shall be delivered to the Contract Compliance Section and shall be handled and considered in the same manner as set forth in paragraph (c) of "Good Faith Effort Procedures" of this Special Provision, except a final decision that a good faith effort was not made during contract performance to achieve the goal agreed to in the Utilization Plan shall be the final administrative decision of the Department.

DOWEL BARS (BDE)

Effective: April 1, 2007

Revised: January 1, 2008

Revise the fifth and sixth sentences of Article 1006.11(b) of the Standard Specifications to read:

"The bars shall be epoxy coated according to AASHTO M 284, except the thickness of the epoxy shall be 7 to 12 mils (0.18 to 0.30 mm) and patching of the ends will not be required. The epoxy coating applicator shall be certified according to the current Bureau of Materials and Physical Research Policy Memorandum, "Epoxy Coating Plant Certification Procedure". The Department will maintain an approved list."

ENGINEER'S FIELD OFFICE TYPE A (BDE)

Effective: April 1, 2007

Revised: August 1, 2008

Revise Article 670.02 of the Standard Specifications to read:

670.02 Engineer's Field Office Type A. Type A field offices shall have a minimum ceiling height of 7 ft (2 m) and a minimum floor space 450 sq ft (42 sq m). The office shall be provided with sufficient heat, natural and artificial light, and air conditioning.

The office shall have an electronic security system that will respond to any breach of exterior doors and windows. Doors and windows shall be equipped with locks. Doors shall also be equipped with dead bolt locks or other secondary locking device.

Windows shall be equipped with exterior screens to allow adequate ventilation. All windows shall be equipped with interior shades, curtains, or blinds. Adequate all-weather parking space shall be available to accommodate a minimum of ten vehicles.

Suitable on-site sanitary facilities meeting Federal, State, and local health department requirements shall be provided, maintained clean and in good working condition, and shall be stocked with lavatory and sanitary supplies at all times.

Sanitary facilities shall include hot and cold potable running water, lavatory and toilet as an integral part of the office where available. Solid waste disposal consisting of two waste baskets and an outside trash container of sufficient size to accommodate a weekly provided pick-up service.

In addition, the following furniture and equipment shall be furnished.

- (a) Four desks with minimum working surface 42 x 30 in. (1.1 m x 750 mm) each and five non-folding chairs with upholstered seats and backs.
- (b) One desk with minimum working surface 48 x 72 in. (1.2 x 1.8 m) with height adjustment of 23 to 30 in. (585 to 750 mm).
- (c) One four-post drafting table with minimum top size of 37 1/2 x 48 in. (950 mm x 1.2 m). The top shall be basswood or equivalent and capable of being tilted through an angle of 50 degrees. An adjustable height drafting stool with upholstered seat and back shall also be provided.
- (d) Two free standing four drawer legal size file cabinet with lock and an underwriters' laboratories insulated file device 350 degrees one hour rating.
- (e) One 6 ft (1.8 m) folding table with six folding chairs.
- (f) One equipment cabinet of minimum inside dimension of 44 in. (1100 mm) high x 24 in. (600 mm) wide x 30 in. (750 mm) deep with lock. The walls shall be of steel with a 3/32 in. (2 mm) minimum thickness with concealed hinges and enclosed lock constructed in such a manner as to prevent entry by force. The cabinet assembly shall be permanently attached to a structural element of the field office in a manner to prevent theft of the entire cabinet.
- (g) One refrigerator with a minimum size of 16 cu ft (0.45 cu m) with a freezer unit.
- (h) One electric desk type tape printing calculator.
- (i) A minimum of two communication paths. The configuration shall include:
 - (1) Internet Connection. An internet service connection using telephone DSL, cable broadband, or CDMA wireless technology. Additionally, an 802.11g/N wireless router shall be provided, which will allow connection by the Engineer and up to four Department staff.
 - (2) Telephone Lines. Three separate telephone lines.

- (j) One plain paper copy machine capable of reproducing prints up to 11 x 17 in. (280 x 432 mm) with an automatic feed tray capable of storing 30 sheets of paper. Letter size and 11 x 17 in. (280 x 432 mm) paper shall be provided.
- (k) One plain paper fax machine with paper.
- (l) Two telephones, with touch tone, where available, and a digital telephone answering machine, for exclusive use by the Engineer.
- (m) One electric water cooler dispenser.
- (n) One first-aid cabinet fully equipped.
- (o) One microwave oven, 1 cu ft (0.03 cu m) minimum capacity.
- (p) One fire-proof safe, 0.5 cu ft (0.01 cu m) minimum capacity.
- (q) One electric paper shredder.
- (r) One post mounted rain gauge, located on the project site for each 5 miles (8 km) of project length.”

Revise the first sentence of the first paragraph of Article 670.07 of the Standard Specifications to read:

“The building or buildings fully equipped as specified will be paid for on a monthly basis until the building or buildings are released by the Engineer.”

Revise the last sentence of the first paragraph of Article 670.07 of the Standard Specifications to read:

“This price shall include all utility costs and shall reflect the salvage value of the building or buildings, equipment, and furniture which become the property of the Contractor after release by the Engineer, except that the Department will pay that portion of the monthly long distance telephone bills that, when combined, exceed \$150.”

EQUIPMENT RENTAL RATES (BDE)

Effective: August 2, 2007

Revised: January 2, 2008

Replace the second and third paragraphs of Article 105.07(b)(4)a. of the Standard Specifications with the following:

“Equipment idled which cannot be used on other work, and which is authorized to standby on the project site by the Engineer, will be paid for according to Article 109.04(b)(4).”

Replace Article 109.04(b)(4) of the Standard Specifications with the following:

“(4) Equipment. Equipment used for extra work shall be authorized by the Engineer. The equipment shall be specifically described, be of suitable size and capacity for the work to be performed, and be in good operating condition. For such equipment, the Contractor will be paid as follows.

- a. Contractor Owned Equipment. Contractor owned equipment will be paid for by the hour using the applicable FHWA hourly rate from the “Equipment Watch Rental Rate Blue Book” (Blue Book) in effect when the force account work begins. The FHWA hourly rate is calculated as follows.

$$\text{FHWA hourly rate} = (\text{monthly rate}/176) \times (\text{model year adj.}) \times (\text{Illinois adj.}) + \text{EOC}$$

Where: EOC = Estimated Operating Costs per hour (from the Blue Book)

The time allowed will be the actual time the equipment is operating on the extra work. For the time required to move the equipment to and from the site of the extra work and any authorized idle (standby) time, payment will be made at the following hourly rate: $0.5 \times (\text{FHWA hourly rate} - \text{EOC})$.

All time allowed shall fall within the working hours authorized for the extra work.

The rates above include the cost of fuel, oil, lubrication, supplies, small tools, necessary attachments, repairs, overhaul and maintenance of any kind, depreciation, storage, overhead, profits, insurance, and all incidentals. The rates do not include labor.

The Contractor shall submit to the Engineer sufficient information for each piece of equipment and its attachments to enable the Engineer to determine the proper equipment category. If a rate is not established in the Blue Book for a particular piece of equipment, the Engineer will establish a rate for that piece of equipment that is consistent with its cost and use in the industry.

- b. Rented Equipment. Whenever it is necessary for the Contractor to rent equipment to perform extra work, the rental and transportation costs of the equipment plus five percent for overhead will be paid. In no case shall the rental rates exceed those of established distributors or equipment rental agencies.

All prices shall be agreed to in writing before the equipment is used.”

HOT-MIX ASPHALT – ANTI-STRIPPING ADDITIVE (BDE)

Effective: November 1, 2009

Revise the first and second paragraphs of Article 1030.04(c) of the Standard Specifications to read:

- “(c) Determination of Need for Anti-Stripping Additive. The mixture designer shall determine if an additive is needed in the mix to prevent stripping. The determination will be made on the basis of tests performed according to Illinois Modified AASHTO T 283.

To be considered acceptable by the Department as a mixture not susceptible to stripping, the conditioned to unconditioned split tensile strength ratio (TSR) shall be equal to or greater than 0.85 for 6 in. (150 mm) specimens. Mixtures, either with or without an additive, with TSRs less than 0.85 for 6 in. (150 mm) specimens will be considered unacceptable. Also, the conditioned tensile strength for mixtures containing an anti-strip additive shall not be lower than the original conditioned tensile strength determined for the same mixture without the anti-strip additive.

If it is determined that an additive is required, the additive may be hydrated lime, slaked quicklime, or a liquid additive, at the Contractor's option.”

HOT-MIX ASPHALT - DENSITY TESTING OF LONGITUDINAL JOINTS (BDE)

Effective: January 1, 2010

Description. This work shall consist of testing the density of longitudinal joints as part of the quality control/quality assurance (QC/QA) of hot-mix asphalt (HMA). Work shall be according to Section 1030 of the Standard Specifications except as follows.

Quality Control/Quality Assurance (QC/QA). Delete the second and third sentence of the third paragraph of Article 1030.05(d)(3) of the Standard Specifications.

Add the following paragraphs to the end of Article 1030.05(d)(3) of the Standard Specifications:

“Longitudinal joint density testing shall be performed at each random density test location. Longitudinal joint testing shall be located at a distance equal to the lift thickness or a minimum of 2 in. (50 mm), from each pavement edge. (i.e. for a 4 in. (100 mm) lift the near edge of the density gauge or core barrel shall be within 4 in. (100 mm) from the edge of pavement.) Longitudinal joint density testing shall be performed using either a correlated nuclear gauge or cores.

- a. Confined Edge. Each confined edge density shall be represented by a one-minute nuclear density reading or a core density and shall be included in the average of density readings or core densities taken across the mat which represents the Individual Test.
- b. Unconfined Edge. Each unconfined edge joint density shall be represented by an average of three one-minute density readings or a single core density at the given density test location and shall meet the density requirements specified herein. The three one-minute readings shall be spaced ten feet apart longitudinally along the unconfined pavement edge and centered at the random density test location.”

Revise the Density Control Limits table in Article 1030.05(d)(4) of the Standard Specifications to read:

"Mixture Composition	Parameter	Individual Test (includes confined edges)	Unconfined Edge Joint Density Minimum
IL-9.5, IL-12.5	Ndesign ≥ 90	92.0 – 96.0%	90.0%
IL-9.5,IL-9.5L, IL-12.5	Ndesign < 90	92.5 – 97.4%	90.0%
IL-19.0, IL-25.0	Ndesign ≥ 90	93.0 – 96.0%	90.0%
IL-19.0, IL-19.0L, IL-25.0	Ndesign < 90	93.0 – 97.4%	90.0%
SMA	Ndesign = 50 & 80	93.5 – 97.4%	91.0%
All Other	Ndesign = 30	93.0 - 97.4%	90.0%”

HOT-MIX ASPHALT – DROP-OFFS (BDE)

Effective: January 1, 2010

Revise the third paragraph of Article 701.07 of the Standard Specifications to read:

“At locations where construction operations result in a differential in elevation exceeding 3 in. (75 mm) between the edge of pavement or edge of shoulder within 3 ft (900 mm) of the edge of the pavement and the earth or aggregate shoulders, Type I or II barricades or vertical panels shall be placed at 100 ft (30 m) centers on roadways where the posted speed limit is 45 mph or greater and at 50 ft (15 m) centers on roadways where the posted speed limit is less than 45 mph.”

HOT-MIX ASPHALT - FINE AGGREGATE (BDE)

Effective: April 1, 2010

Add the following to the gradation tables of Article 1003.01(c) of the Standard Specifications:

"FINE AGGREGATE GRADATIONS					
Grad No.	Sieve Size and Percent Passing				
	3/8	No. 4	No. 8	No. 16	No. 200
FA 22	100	6/	6/	8±8	2±2

FINE AGGREGATE GRADATIONS (Metric)					
Grad No.	Sieve Size and Percent Passing				
	9.5 mm	4.75 mm	2.36 mm	1.18 mm	75 µm
FA 22	100	6/	6/	8±8	2±2

6/ For the fine aggregate gradation FA 22, the aggregate producer shall set the midpoint percent passing, and the Department will apply a range of ± ten percent. The midpoint shall not be changed without Department approval.”

Revise Article 1003.03(a) of the Standard Specifications to read:

“(a) Description. Fine aggregate for HMA shall consist of sand, stone sand, chats, slag sand, or steel slag sand. For gradation FA 22, uncrushed material will not be permitted.”

Revise Article 1003.03(c) of the Standard Specifications to read:

“(c) Gradation. The fine aggregate gradation for all HMA shall be FA 1, FA 2, FA 20, FA 21, or FA 22.

Gradation FA 1, FA 2, or FA 3 shall be used when required for prime coat aggregate application for HMA.”

HOT-MIX ASPHALT – PLANT TEST FREQUENCY (BDE)

Effective: April 1, 2008

Revised: January 1, 2010

Revise the table in Article 1030.05(d)(2)a. of the Standard Specifications to read:

"Parameter	Frequency of Tests	Frequency of Tests	Test Method
	High ESAL Mixture Low ESAL Mixture	All Other Mixtures	See Manual of Test Procedures for Materials
Aggregate Gradation % passing sieves: 1/2 in. (12.5 mm), No. 4 (4.75 mm), No. 8 (2.36 mm), No. 30 (600 μm) No. 200 (75 μm) Note 1.	1 washed ignition oven test on the mix per half day of production Note 4.	1 washed ignition oven test on the mix per day of production Note 4.	Illinois Procedure
Asphalt Binder Content by Ignition Oven Note 2.	1 per half day of production	1 per day	Illinois-Modified AASHTO T 308
VMA Note 3.	Day's production ≥ 1200 tons: 1 per half day of production Day's production < 1200 tons: 1 per half day of production for first 2 days and 1 per day thereafter (first sample of the day)	N/A	Illinois Modified AASHTO R 35
Air Voids Bulk Specific Gravity of Gyratory Sample	Day's production ≥ 1200 tons: 1 per half day of production Day's production < 1200 tons: 1 per half day of production for first 2 days and 1 per day thereafter (first sample of the day)	1 per day	Illinois-Modified AASHTO T 312

Maximum Specific Gravity of Mixture	Day's production \geq 1200 tons: 1 per half day of production	1 per day	Illinois-Modified AASHTO T 209
	Day's production < 1200 tons: 1 per half day of production for first 2 days and 1 per day thereafter (first sample of the day)		

Note 1. The No. 8 (2.36 mm) and No. 30 (600 μ m) sieves are not required for All Other Mixtures.

Note 2. The Engineer may waive the ignition oven requirement for asphalt binder content if the aggregates to be used are known to have ignition asphalt binder content calibration factors which exceed 1.5 percent. If the ignition oven requirement is waived, other Department approved methods shall be used to determine the asphalt binder content.

Note 3. The G_{sb} used in the voids in the mineral aggregate (VMA) calculation shall be the same average G_{sb} value listed in the mix design.

Note 4. The Engineer reserves the right to require additional hot bin gradations for batch plants if control problems are evident.”

HOT-MIX ASPHALT – QC/QA ACCEPTANCE CRITERIA (BDE)

Effective: January 1, 2010

Revise Article 1030.05(f)(3) of the Standard Specifications to read:

“(3) Department assurance tests for voids, field VMA, and density.”

HOT-MIX ASPHALT – TRANSPORTATION (BDE)

Effective: April 1, 2008

Revise Article 1030.08 of the Standard Specifications to read:

“1030.08 Transportation. Vehicles used in transporting HMA shall have clean and tight beds. The beds shall be sprayed with asphalt release agents from the Department’s approved list. In lieu of a release agent, the Contractor may use a light spray of water with a light scatter of manufactured sand (FA 20 or FA 21) evenly distributed over the bed of the vehicle. After spraying, the bed of the vehicle shall be in a completely raised position and it shall remain in this position until all excess asphalt release agent or water has been drained.

When the air temperature is below 60 °F (15 °C), the bed, including the end, endgate, sides and bottom shall be insulated with fiberboard, plywood or other approved insulating material and shall have a thickness of not less than 3/4 in (20 mm). When the insulation is placed inside the bed, the insulation shall be covered with sheet steel approved by the Engineer. Each vehicle shall be equipped with a cover of canvas or other suitable material meeting the approval of the Engineer which shall be used if any one of the following conditions is present.

- (a) Ambient air temperature is below 60 °F (15 °C).
- (b) The weather is inclement.
- (c) The temperature of the HMA immediately behind the paver screed is below 250 °F (120 °C).

The cover shall extend down over the sides and ends of the bed for a distance of approximately 12 in. (300 mm) and shall be fastened securely. The covering shall be rolled back before the load is dumped into the finishing machine.”

IMPACT ATTENUATORS (BDE)

Effective: November 1, 2003

Revised: November 1, 2008

Description. This work shall consist of furnishing and installing impact attenuators of the category and test level specified.

Materials. Materials shall meet the requirements of the impact attenuator manufacturer and the following:

Item	Article/Section
(a) Fine Aggregate (Note 1).....	1003.01
(b) Steel Posts, Structural Shapes, and Plates	1006.04
(c) Rail Elements, End Section Plates, and Splice Plates	1006.25
(d) Bolts, Nuts, Washers and Hardware	1006.25
(e) Hollow Structural Tubing	1006.27(b)
(f) Wood Posts and Wood Blockouts	1007.01, 1007.02, 1007.06
(g) Preservative Treatment.....	1007.12

Note 1. Fine aggregate shall be FA 1 or FA 2, Class A quality. The sand shall be unbagged and shall have a maximum moisture content of five percent.

CONSTRUCTION REQUIREMENTS

General. Impact attenuators shall meet the testing criteria contained in National Cooperative Highway Research Program (NCHRP) Report 350 for the test level specified and shall be on the Department’s approved list. Fully redirective and partially redirective attenuators shall also be designed for bi-directional impacts.

Installation. Regrading of slopes or approaches for the installation shall be as shown on the plans.

Bases for impact attenuators, other than sand modules, shall be installed when required by the manufacturer. The bases shall be constructed on a prepared subgrade according to the manufacturer’s specifications. The surface of the base shall be slightly sloped or crowned to facilitate drainage.

Bases for sand module impact attenuators will be required. The bases shall be constructed of either portland cement concrete or hot-mix asphalt (HMA). Portland cement concrete bases shall be 6 in. (150 mm) thick and be according to the applicable requirements of Section 424 of the Standard Specifications.

HMA bases shall be 8 in. (200 mm) thick and be according to the applicable requirements of Section 408 of the Standard Specifications. The surface of the base shall be slightly sloped or crowned to facilitate drainage. The perimeter of each module and the specified weight (mass) of sand in each module shall be painted on the surface of the base.

Impact attenuators shall be installed according to the manufacturer's specifications and include all necessary transitions between the impact attenuator and the item to which it is attached.

Method of Measurement. This work will be measured for payment as each, where each is defined as one complete installation.

Contract quantities for sand module attenuator bases may be accepted according to Article 202.07(a) of the Standard Specifications. When measured, sand module attenuator bases will be measured in place and the dimensions used to calculate square yards (square meters) will not exceed those as shown on the plans.

Basis of Payment. This work, will be paid for at the contract unit price per each for IMPACT ATTENUATORS (FULLY REDIRECTIVE, NARROW); IMPACT ATTENUATORS (FULLY REDIRECTIVE, WIDE); IMPACT ATTENUATORS (FULLY REDIRECTIVE, RESETTABLE); IMPACT ATTENUATORS (SEVERE USE, NARROW); IMPACT ATTENUATORS (SEVERE USE, WIDE); IMPACT ATTENUATORS (PARTIALLY REDIRECTIVE); or IMPACT ATTENUATORS (NON-REDIRECTIVE), of the test level specified.

Sand module attenuator bases will be paid for at the contract unit price per square yard (square meter) for ATTENUATOR BASE.

Regrading of slopes or approaches will be paid for according to Section 202 and/or Section 204 of the Standard Specifications.

IMPACT ATTENUATORS, TEMPORARY (BDE)

Effective: November 1, 2003

Revised: January 1, 2007

Description. This work shall consist of furnishing, installing, maintaining, and removing temporary impact attenuators of the category and test level specified.

Materials. Materials shall meet the requirements of the impact attenuator manufacturer and the following:

Item	Article/Section
(a) Fine Aggregate (Note 1)	003.01
(b) Steel Posts, Structural Shapes, and Plates	1006.04
(c) Rail Elements, End Section Plates, and Splice Plates	1006.25
(d) Bolts, Nuts, Washers and Hardware	1006.25
(e) Hollow Structural Tubing	1006.27(b)
(f) Wood Posts and Wood Blockouts	1007.01, 1007.02, 1007.06
(g) Preservative Treatment	1007.12
(h) Packaged Rapid Hardening Mortar	1018.01

Note 1. Fine aggregate shall be FA 1 or FA 2, Class A quality. The sand shall be unbagged and shall have a maximum moisture content of five percent.

CONSTRUCTION REQUIREMENTS

General. Impact Attenuators shall meet the testing criteria contained in National Cooperative Highway Research Program (NCHRP) Report 350 for the test level specified and shall be on the Department's approved list.

Installation. Regrading of slopes or approaches for the installation shall be as shown on the plans.

Attenuator bases, when required by the manufacturer, shall be constructed on a prepared subgrade according to the manufacturer's specifications. The surface of the base shall be slightly sloped or crowned to facilitate drainage.

Impact attenuators shall be installed according to the manufacturer's specifications and include all necessary transitions between the impact attenuator and the item to which it is attached.

When water filled attenuators are used between November 1 and April 15, they shall contain anti-freeze according to the manufacturer's recommendations.

Markings. Sand module impact attenuators shall be striped with alternating reflectorized Type AA or Type AP fluorescent orange and reflectorized white horizontal, circumferential stripes. There shall be at least two of each stripe on each module.

Other types of impact attenuators shall have a terminal marker applied to their nose and reflectors along their sides.

Maintenance. All maintenance of the impact attenuators shall be the responsibility of the Contractor until removal is directed by the Engineer.

Relocate. When relocation of temporary impact attenuators is specified, they shall be removed, relocated and reinstalled at the new location. The reinstallation requirements shall be the same as those for a new installation.

Removal. When the Engineer determines the temporary impact attenuators are no longer required, the installation shall be dismantled with all hardware becoming the property of the Contractor.

Surplus material shall be disposed of according to Article 202.03. Anti-freeze, when present, shall be disposed of/recycled according to local ordinances.

When impact attenuators have been anchored to the pavement, the anchor holes shall be repaired with rapid set mortar. Only enough water to permit placement and consolidation by rodding shall be used and the material shall be struck-off flush.

Method of Measurement. This work will be measured for payment as each, where each is defined as one complete installation.

Basis of Payment. This work will be paid for at the contract unit price per each for IMPACT ATTENUATORS, TEMPORARY (FULLY REDIRECTIVE, NARROW); IMPACT ATTENUATORS, TEMPORARY (FULLY REDIRECTIVE, WIDE); IMPACT ATTENUATORS, TEMPORARY (FULLY REDIRECTIVE, RESETTABLE); IMPACT ATTENUATORS, TEMPORARY (SEVERE USE, NARROW); IMPACT ATTENUATORS, TEMPORARY (SEVERE USE, WIDE); or IMPACT ATTENUATORS, TEMPORARY (NON-REDIRECTIVE) of the test level specified.

Relocation of the devices will be paid for at the contract unit price per each for IMPACT ATTENUATORS, RELOCATE (FULLY REDIRECTIVE); IMPACT ATTENUATORS, RELOCATE (SEVERE USE); or IMPACT ATTENUATORS, RELOCATE (NON-REDIRECTIVE); of the test level specified.

Regrading of slopes or approaches will be paid for according to Section 202 and/or Section 204 of the Standard Specifications.

IMPROVED SUBGRADE (BDE)

Effective: January 1, 2010

Revise the second paragraph of Article 302.04 of the Standard Specifications to read:

“The quantity of modified soil constructed shall be limited to that which can be covered by the full thickness of portland cement concrete pavement or HMA binder during the same construction season.”

Revise the first paragraph of Article 302.07 of the Standard Specifications to read:

“**302.07 Application of Modifier.** The modifier shall be applied uniformly on the soil. The application of modifier shall be limited to that amount which can be mixed with the soil within the same working day.”

Revise the first paragraph of Article 302.08 of the Standard Specifications to read:

“**302.08 Mixing.** The modifier, soil, and water shall be thoroughly mixed. Mixing shall continue until a homogenous layer of the required thickness has been obtained and a minimum of 75 percent of the mixture is smaller than 1 in. (25 mm). The moisture content of the modified soil shall be above optimum moisture content with a maximum of three percent above optimum.”

Revise Article 302.10 of the Standard Specifications to read:

“ **302.10 Finishing and Curing.** When multiple lifts are used to construct the modified soil layer, the top lift shall be a minimum of 6 in. (150 mm) thick when compacted.

Construction of pipe underdrains shall follow the requirements of Article 407.07. The surface of the modified soil shall be kept drained according to Article 301.09 and shall maintain moisture content not exceeding three percent above optimum prior to pavement construction.

When compaction of the modified soil is nearing completion, the surface shall be shaped to the required lines, grades, and cross section shown on the plans.

For HMA base course and pavement (full-depth) and portland cement concrete base course and pavement, the surface of the modified soil shall be brought to true shape and correct elevation according to Article 301.07, except well compacted earth shall not be used to fill low areas.

The modified soil shall be cured for a minimum of 24 hours. The ambient air temperature shall be above 45 °F (7 °C) during curing.

During the curing period, the moisture content of the modified soil shall be maintained at optimum by sprinkling with water, use of plastic sheeting, or applying bituminous materials according to Article 312.14. During this period, no equipment or traffic will be permitted on the completed work beyond that required for maintenance of curing.

Equipment of such weight, or used in such a way as to cause a rut depth of 1/2 in. (13 mm) or more in the finished modified soil, shall be removed, or the rutting otherwise prevented, as directed by the Engineer.”

Revise the first paragraph of Article 302.11 of the Standard Specifications to read:

“**302.11 Subgrade Stability.** Following curing, the Engineer will determine the stability of the modified soil in terms of the immediate bearing value (IBV), according to Illinois Test Procedure 501. The IBV shall be a minimum of 10.0 measured within 10 calendar days prior to pavement construction.”

Revise the second paragraph of Article 310.04 of the Standard Specifications to read:

“The quantity of lime stabilized soil mixture constructed shall be limited to that which can be covered by the full thickness of portland cement concrete pavement or HMA binder during the same construction season.”

Revise the first paragraph of Article 310.08(a) of the Standard Specifications to read:

“(a) Initial Mixing. The lime, soil, and water shall be thoroughly mixed until a uniform mixture throughout the required depth and width is obtained. All clods and lumps shall be reduced to a maximum size of 2 in. (50 mm). The moisture content of the stabilized soil shall be above optimum moisture content with a maximum of three percent above optimum.”

Insert the following paragraph after the first paragraph of Article 310.10 of the Standard Specifications:

“Construction of pipe underdrains shall follow the requirements of Article 407.07. The surface of the lime stabilized soil shall be kept drained according to Article 301.09 and shall maintain a maximum moisture content of three percent above optimum prior to pavement construction.”

Revise the first paragraph of Article 310.11 of the Standard Specifications to read:

“310.11 Subgrade Stability. Following curing, the Engineer will determine the stability of the lime stabilized soil mixture in terms of the immediate bearing value (IBV) according to Illinois Test Procedure 501. The IBV shall be a minimum of 23.0 measured within 10 calendar days prior to pavement construction.”

Revise the second paragraph of Article 311.05 of the Standard Specifications to read:

“The granular material shall be placed and compacted at least three days prior to the placement of pavement or base course. Except where required for temporary access, the quantity of subbase granular material Types A or B to be placed shall be limited to that which can be covered by the full thickness of PCC pavement or HMA binder during the same construction season.”

LIQUIDATED DAMAGES (BDE)

Effective: April 1, 2009

Revise the table in Article 108.09 of the Standard Specifications to read:

“Schedule of Deductions for Each Day of Overrun in Contract Time			
Original Contract Amount		Daily Charges	
From More Than	To and Including	Calendar Day	Work Day
\$ 0	\$ 100,000	\$ 375	\$ 500
100,000	500,000	625	875
500,000	1,000,000	1,025	1,425
1,000,000	3,000,000	1,125	1,550
3,000,000	5,000,000	1,425	1,950
5,000,000	10,000,000	1,700	2,350
10,000,000	And over	3,325	4,650”

MATERIAL TRANSFER DEVICE (BDE)

Effective Date: June 15, 1999

Revised Date: January 1, 2009

Description. This work shall consist of placing Polymer Hot Mix Asphalt Surface Course, Mix “D”, N105, except that these materials shall be placed using a material transfer device.

Materials and Equipment. The material transfer device shall have a minimum surge capacity of 15 tons (13.5 metric tons), shall be self-propelled and capable of moving independent of the paver, and shall be equipped with the following:

- (a) Front-Dump Hopper and Conveyor. The conveyor shall provide a positive restraint along the sides of the conveyor to prevent material spillage. Material Transfer devices having paver style hoppers shall have a horizontal bar restraint placed across the foldable wings which prevents the wings from being folded.

- (b) Paver Hopper Insert. The paver hopper insert shall have a minimum capacity of 14 tons (12.7 metric tons).
- (c) Mixer/Agitator Mechanism. This re-mixing mechanism shall consist of a segmented, anti-segregation, re-mixing auger or two full-length longitudinal paddle mixers designed for the purpose of re-mixing the hot-mix asphalt (HMA). The longitudinal paddle mixers shall be located in the paver hopper insert.

CONSTRUCTION REQUIREMENTS

General. The material transfer device shall be used for the placement of Polymer Hot Mix Asphalt Surface Course, Mix "D", N105. The material transfer device speed shall be adjusted to the speed of the paver to maintain a continuous, non-stop paving operation.

Use of a material transfer device with a roadway contact pressure exceeding 20 psi (138 kPa) will be limited to partially completed segments of full-depth HMA pavement where the thickness of binder in place is 10 in. (250 mm) or greater.

Structures. The material transfer device may be allowed to travel over structures under the following conditions:

- (a) Approval will be given by the Engineer.
- (b) The vehicle shall be emptied of HMA material prior to crossing the structure and shall travel at crawl speed across the structure.
- (c) The tires of the vehicle shall travel on or in close proximity and parallel to the beam and/or girder lines of the structure.

Method of Measurement. This work will be measured for payment in tons (metric tons) for Polymer Hot Mix Asphalt Surface Course, Mix "D", N105 materials placed with a material transfer device.

Basis of Payment. This work will be paid for at the contract unit price per ton (metric ton) for MATERIAL TRANSFER DEVICE.

The various HMA mixtures placed with the material transfer device will be paid for as specified in their respective specifications. The Contractor may choose to use the material transfer device for other applications on this project; however, no additional compensation will be allowed.

METAL HARDWARE CAST INTO CONCRETE (BDE)

Effective: April 1, 2008

Revised: April 1, 2009

Add the following to Article 503.02 of the Standard Specifications:

“(g) Metal Hardware Cast into Concrete 1006.13”

Add the following to Article 504.02 of the Standard Specifications:

“(j) Metal Hardware Cast into Concrete 1006.13”

Revise Article 1006.13 of the Standard Specifications to read:

“**1006.13 Metal Hardware Cast into Concrete.** Unless otherwise noted, all steel hardware cast into concrete, such as inserts, brackets, cable clamps, metal casings for formed holes, and other miscellaneous items, shall be galvanized according to AASHTO M 232 or AASHTO M 111. Aluminum inserts will not be allowed. Zinc alloy inserts shall be according to ASTM B 86, Alloys 3, 5, or 7.

The inserts shall be UNC threaded type anchorages having the following minimum certified proof load.

Insert Diameter	Proof Load
5/8 in. (16 mm)	6600 lb (29.4 kN)
3/4 in. (19 mm)	6600 lb (29.4 kN)
1 in. (25 mm)	9240 lb (41.1 kN)”

MULTILANE PAVEMENT PATCHING (BDE)

Effective: November 1, 2002

Pavement broken and holes opened for patching shall be completed prior to weekend or holiday periods. Should delays of any type or for any reason prevent the completion of the work, temporary patches shall be constructed. Material able to support the average daily traffic and meeting the approval of the Engineer shall be used for the temporary patches. The cost of furnishing, placing, maintaining, removing and disposing of the temporary work, including traffic control, shall be the responsibility of the Contractor.

NATIONAL POLLUTANT DISCHARGE ELIMINATION SYSTEM / EROSION AND SEDIMENT CONTROL DEFICIENCY DEDUCTION (BDE)

Effective: April 1, 2007

Revised: November 1, 2009

Revise Article 105.03(a) of the Standard Specifications to read:

“(a) National Pollutant Discharge Elimination System (NPDES) / Erosion and Sediment Control Deficiency Deduction When the Engineer is notified or determines an erosion and/or sediment control deficiency(s) exists, or the Contractor’s activities represents a violation of the Department’s NPDES permits, the Engineer will notify and direct the Contractor to correct the deficiency within a specified time. The specified time, which begins upon notification to the Contractor, will be from 1/2 hour to 1 week based on the urgency of the situation and the nature of the work effort required. The Engineer will be the sole judge.

A deficiency may be any lack of repair, maintenance, or implementation of erosion and/or sediment control devices included in the contract, or any failure to comply with the conditions of the Department’s NPDES permits.

A deficiency may also be applied to situations where corrective action is not an option such as the failure to participate in a jobsite inspection of the project, failure to install required measures prior to initiating earth moving operations, disregard of concrete washout requirements, or other disregard of the NPDES permit.

If the Contractor fails to correct a deficiency within the specified time, a daily monetary deduction will be imposed for each calendar day or portion of a calendar day until the deficiency is corrected to the satisfaction of the Engineer. The calendar day(s) will begin with notification to the Contractor and end with the Engineer's acceptance of the correction. The base value of the daily monetary deduction is \$1000.00 and will be applied to each location for which a deficiency exists. The value of the deficiency deduction assessed for each infraction will be determined by multiplying the base value by a Gravity Adjustment Factor provided in Table A. Except for failure to participate in a required jobsite inspection of the project prior to initiating earthmoving operations which will be based on the total acreage of planned disturbance at the following multipliers: <5 Acres: 1; 5-10 Acres: 2; >10-25 Acres: 3; >25 Acres: 5. For those deficiencies where corrective action was not an option, the monetary deduction will be immediate and will be valued at one calendar day multiplied by a Gravity Adjustment Factor.

Table A Deficiency Deduction Gravity Adjustment Factors				
Types of Violations	Soil Disturbed and Not Permanently Stabilized At Time of Violation			
	< 5 Acres	5 - 10 Acres	>10 - 25 Acres	> 25 Acres
Failure to Install or Properly Maintain BMP	0.1 - 0.5	0.2 - 1.0	0.5 - 2.5	1.0 - 5
Careless Destruction of BMP	0.2 - 1	0.5 - 2.5	1.0 - 5.	1.0 - 5
Intrusion into Protected Resource	1.0 - 5	1.0 - 5	2.0 - 10	2.0 - 10
Failure to properly manage Chemicals, Concrete Washouts or Residuals, Litter or other Wastes	0.2 - 1	0.2 - 1	0.5 - 2.5	1.0 - 5
Improper Vehicle and Equipment Maintenance, Fueling or Cleaning	0.1 - 0.5	0.2 - 1	0.2 - 1	0.5 - 2.5
Failure to Provide or Update Written or Graphic Plans Required by SWPPP	0.2 - 1	0.5 - 2.5	1.0 - 5	1.0 - 5
Failure to comply with Other Provisions of the NPDES Permit	0.1 - 0.5	0.2 - 1	0.2 - 1	0.5 - 2.5"

NOTIFICATION OF REDUCED WIDTH (BDE)

Effective: April 1, 2007

Add the following after the first paragraph of Article 701.06 of the Standard Specifications:

“Where the clear width through a work zone with temporary concrete barrier will be 16.0 ft (4.88 m) or less, the Contractor shall notify the Engineer at least 21 days in advance of implementing the traffic control for that restriction.”

ORGANIC ZINC-RICH PAINT SYSTEM (BDE)

Effective: November 1, 2001

Revised: January 1, 2010

Add the following to Section 1008 of the Standard Specifications:

“1008.05 Organic Zinc-Rich Paint System. The organic zinc-rich paint system shall consist of an organic zinc-rich primer, an epoxy or urethane intermediate coat, and aliphatic urethane finish coats. It is intended for use over blast-cleaned steel when three-coat shop applications are specified. The system is also suitable for field painting blast-cleaned existing structures.

The coating system shall be evaluated for performance through the National Transportation Product Evaluation Program (NTPEP) for Structural Steel Coatings following the requirements of AASHTO R 31, and shall meet the performance criteria listed herein. After successful NTPEP testing, the coatings shall be submitted to the Illinois Department of Transportation, Bureau of Materials and Physical Research, for qualification and acceptance testing.

(a) General Requirements.

- (1) Compatibility. Each coating in the system shall be supplied by the same paint manufacturer.
- (2) Toxicity. Each coating shall contain less than 0.01 percent lead in the dry film and no more than trace amounts of hexavalent chromium, cadmium, mercury or other toxic heavy metals.
- (3) Volatile Organics. The volatile organic compounds of each coating shall not exceed 2.8 lb/gal (340 g/L) as applied.

(b) Panel Preparation for NTPEP testing. The test panels shall be prepared according to AASHTO R 31, except for the following: Test panels shall be scribed according to ASTM D 1654 with a single “X” mark centered on the panel. The rectangular dimensions of the scribe shall have a top width of 2 in. (50 mm) and a height of 4 in. (100 mm). The scribe cut shall expose the steel substrate as verified with a microscope.

(c) Zinc-Rich Primer Requirements.

- (1) Generic Type. This material shall be an organic zinc-rich epoxy or urethane primer. It shall be suitable for topcoating with epoxies, urethanes, and acrylics.
- (2) Zinc Dust. The zinc dust pigment shall comply with ASTM D 520, Type II.
- (3) Slip Coefficient. The organic zinc coating shall meet a Class B AASHTO slip coefficient (0.50 or greater) for structural steel joints using ASTM A 325 (A 325M) or A 490 (A 490M) bolts.
- (4) Adhesion. The adhesion to an abrasively blasted steel substrate shall not be less than 900 psi (6.2 MPa) when tested according to ASTM D 4541 Annex A4.

- (5) Unit Weight. The unit weight of the mixed material shall be within 0.4 lb/gal (48 kg/cu m) of the original qualification sample unit weight when tested according to ASTM D 1475.
 - (6) Percent Solids by Weight of Mixed Primer. The percent solids by weight for the mixed material shall be a minimum of 70 percent and shall not vary more than ± 2 percentage points from the percent solids by weight of the original qualification samples when tested according to ASTM D 2369.
 - (7) Percent Solids by Weight of Vehicle Component. The percent solids by weight of the vehicle component shall not vary more than ± 2 percentage points from the percent solids by weight of the original qualification samples when tested according to ASTM D 2369.
 - (8) Viscosity. The viscosity of the mixed material shall not vary more than ± 10 Krebs Units from the original qualification sample viscosity when tested according to ASTM D 562 at 77 °F (25 °C).
 - (9) Dry Set to Touch. The mixed material when applied at 6 mils (150 microns) wet film thickness shall have a dry set to touch of 30 minutes or less when tested according to ASTM D 1640 at 77°F (25 °C).
 - (10) Pot Life. After sitting eight hours at 77°F (25 °C), the mixed material shall not show curdling, gelling, gassing, or hard caking.
- (d) Intermediate Coat Requirements.
- (1) Generic Type. This material shall be an epoxy or urethane. It shall be suitable as an intermediate coat over inorganic and organic zinc primers and compatible with acrylic, epoxy, and polyurethane topcoats.
 - (2) Color. The color of the intermediate coat shall be white, off-white, or beige.
 - (3) Unit Weight. The unit weight of the mixed material and the unit weight of the individual components shall be within 0.20 lb/gal (24 kg/cu m) of the original qualification sample unit weights when tested according to ASTM D 1475.
 - (4) Percent Solids by Weight. The percent solids by weight for the mixed material shall not vary more than ± 2 percentage points from the percent solids by weight of the original qualification samples when tested according to ASTM D 2369.
 - (5) Dry Time. The mixed material shall be dry to touch in two hours and dry hard in eight hours when applied at 10 mils (255 microns) wet film thickness and tested according to ASTM D 1640.
 - (6) Viscosity. The viscosity of the mixed material shall not vary more than ± 10 Krebs Units from the original qualification samples when tested according to ASTM D 562 at 77 °F (25 °C).

- (7) Pot Life. After sitting two hours at 77°F (25 °C), the mixed material shall not show curdling, gelling, gassing, or hard caking.

(e) Urethane Finish Coat Requirements.

- (1) Generic Type. This material shall be an aliphatic urethane. It shall be suitable as a topcoat over epoxies and urethanes.
- (2) Color and Hiding Power. The finish coat shall match Munsell Glossy Color 7.5G 4/8 Interstate Green, 2.5YR 3/4 Reddish Brown, 10B 3/6 Blue, or 5B 7/1 Gray. The color difference shall not exceed 3.0 Hunter Delta E Units. Color difference shall be measured by instrumental comparison of the designated Munsell standard to a minimum dry film thickness of 3 mils (75 microns) of sample coating produced on a test panel according to ASTM D 823, Practice E, Hand-Held, Blade Film Application. Color measurements shall be determined on a spectrophotometer with 45 degrees circumferential/zero degrees geometry, illuminant C, and two degrees observer angle. The spectrophotometer shall measure the visible spectrum from 380-720 nanometers with a wavelength interval and spectral bandpass of 10 nanometers.
- (3) Contrast Ratio. The contrast ratio of the finish coat applied at 3 mils (75 microns) dry film thickness shall not be less than 0.99 when tested according to ASTM D 2805.
- (4) Weathering Resistance. Test panels shall be aluminum alloy measuring 12 x 4 in. (300 x 100 mm) prepared according to ASTM D 1730 Type A, Method 1 Solvent Cleaning. A minimum dry film thickness of 3 mils (75 microns) of finish coat shall be applied to three test panels according to ASTM D 823, Practice E, Hand Held Blade Film Application. The coated panels shall be cured at least 14 days at 75 °F ± 2 °F (24 °C ± 1 °C) and 50 ± 5 percent relative humidity. The panels shall be subjected to 300 hours of accelerated weathering using the light and water exposure apparatus (fluorescent UV - condensation type) as specified in ASTM G 53-96 and ASTM G 154 (equipped with UVB-313 lamps). The cycle shall consist of eight hours UV exposure at 140 °F (60 °C) followed by four hours of condensation at 104 °F (40 °C). After exposure, rinse the panel with clean water; allow to dry at room temperature for one hour. The exposed panels shall not show a color change of more than 3 Hunter Delta E Units.
- (5) Dry Time. The mixed material shall be dry to touch in two hours and dry hard in six hours when applied at 6 mils (150 microns) wet film thickness and tested according to ASTM D 1640.

(f) Three Coat System Requirements.

- (1) Finish Coat Color. For NTPEP testing purposes, the color of the finish coat shall match the latest applicable AASHTO R 31 specified color.
- (2) Salt Fog. When tested according to ASTM B 117 and evaluated according to AASHTO R 31, the paint system shall exhibit no spontaneous delamination and not exceed the following acceptance levels after scraping after 5,000 hours of salt fog exposure:

Salt Fog Acceptance Criteria		
Blister Criteria	Rust Criteria	
Conversion Value	Maximum Creep	Average Creep
9	4 mm	2 mm

- (3) Cyclic Exposure. When tested according to ASTM D 5894 and evaluated according to AASHTO R 31, the paint system shall exhibit no spontaneous delamination and not exceed the following acceptance levels after 5,000 hours of cyclic exposure:

Cyclic Exposure Acceptance Criteria		
Blister Criteria	Rust Criteria	
Conversion Value	Maximum Creep	Average Creep
9	7 mm	4 mm

- (4) Abrasion. The abrasion resistance shall be evaluated according to ASTM D 4060 using a Taber Abrader with a 2.20 lb (1000 gram) load and CS 17 wheels. The duration of the test shall be 1,000 cycles. The loss shall be calculated by difference and be less than 0.00049 lb (220 mgs).
- (5) Adhesion. The adhesion to an abrasively blasted steel substrate shall not be less than 900 psi (6.2 MPa) when tested according to ASTM D 4541 Annex A4.
- (6) Freeze Thaw Stability. There shall be no reduction of adhesion, which exceeds the test precision, after 30 days of freeze/thaw/immersion testing. One 24 hour cycle shall consist of 16 hours of approximately -22 °F (-30 °C) followed by four hours of thawing at 122 °F (50 °C) and four hours tap water immersion at 77 °F (25 °C). The test panels shall remain in the freezer mode on weekends and holidays.
- (g) Sampling, Testing, Acceptance, and Certification. Sampling, testing, acceptance, and certification of the coating system shall be according to Article 1008.01."

PARTIAL EXIT RAMP CLOSURE FOR FREEWAY/EXPRESSWAY (BDE)

Effective: January 1, 2009

Description. This work shall consist of furnishing and installing traffic control for the partial closure of exit ramps on a freeway/expressway. Work shall be according to Section 701 except as modified herein.

Add the following after the fourth paragraph of Article 701.07 of the Standard Specifications:

"Drop-offs at the edge of pavement greater than 1 1/2 in. (40 mm) caused by the Contractor's operations will be allowed only on one side of the ramp at a time."

Delete the third paragraph of Article 701.17(e)(1) of the Standard Specifications.

Delete the third paragraph of Article 701.18(e)(3) of the Standard Specifications.

Revise the first sentence of Article 701.19(c) of the Standard Specifications to read:

“Traffic control and protection required under Standards 701201, 701206, 701306, 701326, 701336, 701406, 701421, 701456, 701501, 701502, 701601, 701602, 701606, 701701 and 701801 will be measured for payment on a lump sum basis.”

Add the following to the first paragraph of Article 701.20(b) of the Standard Specifications:

“TRAFFIC CONTROL AND PROTECTION STANDARD 701456;”

PAVEMENT MARKING REMOVAL (BDE)

Effective: April 1, 2009

Add the following to the end of the first paragraph of Article 783.03(a) of the Standard Specifications:

“The use of grinders will not be allowed on new surface courses.”

PAVEMENT PATCHING (BDE)

Effective: January 1, 2010

Revise the first sentence of the second paragraph of Article 701.17(e)(1) of the Standard Specifications to read:

“In addition to the traffic control and protection shown elsewhere in the contract for pavement, two devices shall be placed immediately in front of each open patch, open hole, and broken pavement where temporary concrete barriers are not used to separate traffic from the work area.”

PAYMENTS TO SUBCONTRACTORS (BDE)

Effective: June 1, 2000

Revised: January 1, 2006

Federal regulations found at 49 CFR §26.29 mandate the Department to establish a contract clause to require Contractors to pay subcontractors for satisfactory performance of their subcontracts and to set the time for such payments.

State law also addresses the timing of payments to be made to subcontractors and material suppliers. Section 7 of the Prompt Payment Act, 30 ILCS 540/7, requires that when a Contractor receives any payment from the Department, the Contractor shall make corresponding, proportional payments to each subcontractor and material supplier performing work or supplying material within 15 calendar days after receipt of the Department payment. Section 7 of the Act further provides that interest in the amount of two percent per month, in addition to the payment due, shall be paid to any subcontractor or material supplier by the Contractor if the payment required by the Act is withheld or delayed without reasonable cause.

The Act also provides that the time for payment required and the calculation of any interest due applies to transactions between subcontractors and lower-tier subcontractors and material suppliers throughout the contracting chain.

This Special Provision establishes the required federal contract clause, and adopts the 15 calendar day requirement of the State Prompt Payment Act for purposes of compliance with the federal regulation regarding payments to subcontractors. This contract is subject to the following payment obligations.

When progress payments are made to the Contractor according to Article 109.07 of the Standard Specifications, the Contractor shall make a corresponding payment to each subcontractor and material supplier in proportion to the work satisfactorily completed by each subcontractor and for the material supplied to perform any work of the contract. The proportionate amount of partial payment due to each subcontractor and material supplier throughout the contracting chain shall be determined by the quantities measured or otherwise determined as eligible for payment by the Department and included in the progress payment to the Contractor. Subcontractors and material suppliers shall be paid by the Contractor within 15 calendar days after the receipt of payment from the Department. The Contractor shall not hold retainage from the subcontractors. These obligations shall also apply to any payments made by subcontractors and material suppliers to their subcontractors and material suppliers; and to all payments made to lower tier subcontractors and material suppliers throughout the contracting chain. Any payment or portion of a payment subject to this provision may only be withheld from the subcontractor or material supplier to whom it is due for reasonable cause.

This Special Provision does not create any rights in favor of any subcontractor or material supplier against the State or authorize any cause of action against the State on account of any payment, nonpayment, delayed payment, or interest claimed by application of the State Prompt Payment Act. The Department will not approve any delay or postponement of the 15 day requirement except for reasonable cause shown after notice and hearing pursuant to Section 7(b) of the State Prompt Payment Act. State law creates other and additional remedies available to any subcontractor or material supplier, regardless of tier, who has not been paid for work properly performed or material furnished. These remedies are a lien against public funds set forth in Section 23(c) of the Mechanics Lien Act, 770 ILCS 60/23(c), and a recovery on the Contractor's payment bond according to the Public Construction Bond Act, 30 ILCS 550.

PERSONAL PROTECTIVE EQUIPMENT (BDE)

Effective: November 1, 2008

Revise the first sentence of Article 701.12 of the Standard Specifications to read:

“All personnel on foot, excluding flaggers, within the highway right-of-way shall wear a fluorescent orange, fluorescent yellow/green, or a combination of fluorescent orange and fluorescent yellow/green vest meeting the requirements of ANSI/ISEA 107-2004 for Conspicuity Class 2 garments.”

PIPE CULVERTS (BDE)

Effective: April 1, 2009

Revised: April 1, 2010

Revise Tables IIIA, IIIB, and IIIC of Article 542.03 of the Standard Specifications to read:

"PIPE CULVERT TABLE IIIA PLASTIC PIPE PERMITTED FOR A GIVEN PIPE DIAMETER AND FILL HEIGHT OVER THE TOP OF THE PIPE														
Nom. Dia. in.	Type 1 Fill Height: 3' and less with 1' minimum cover							Type 2 Fill Height: Greater than 3', not exceeding 10'						
	PVC	CPVC	PVCPW -794	PVCPW -304	PE	CPE	PEPW	PVC	CPVC	PVCPW -794	PVCPW -304	PE	CPE	PEPW
10	X	NA	NA	NA	X	NA	NA	X	*	NA	NA	X	NA	NA
12	X	X	X	X	X	X	NA	X	X	X	X	X	X	NA
15	X	X	X	X	X	X	NA	X	X	X	X	X	X	NA
18	X	X	X	X	X	X	X	X	X	X	X	X	X	X
21	X	X	X	X	NA	NA	X	X	X	X	X	NA	NA	X
24	X	X	X	X	X	X	X	X	X	X	X	X	X	X
30	X	X	X	X	X	X	X	X	X	X	X	X	X	X
36	X	X	X	X	X	X	X	X	X	X	X	X	X	X
42	NA	NA	X	X	X	X	X	NA	NA	X	X	X	X	X
48	NA	NA	X	X	X	X	X	NA	NA	X	X	X	X	X

PIPE CULVERT TABLE IIIA (metric) PLASTIC PIPE PERMITTED FOR A GIVEN PIPE DIAMETER AND FILL HEIGHT OVER THE TOP OF THE PIPE														
Nom. Dia. mm	Type 1 Fill Height: 1 m and less with 0.3 m minimum cover							Type 2 Fill Height: Greater than 1 m, not exceeding 3 m						
	PVC	CPVC	PVCPW -794	PVCPW -304	PE	CPE	PEPW	PVC	CPVC	PVCPW -794	PVCPW -304	PE	CPE	PEPW
250	X	NA	NA	NA	X	NA	NA	X	*	NA	NA	X	NA	NA
300	X	X	X	X	X	X	NA	X	X	X	X	X	X	NA
375	X	X	X	X	X	X	NA	X	X	X	X	X	X	NA
450	X	X	X	X	X	X	X	X	X	X	X	X	X	X
525	X	X	X	X	NA	NA	X	X	X	X	X	NA	NA	X
600	X	X	X	X	X	X	X	X	X	X	X	X	X	X
750	X	X	X	X	X	X	X	X	X	X	X	X	X	X
900	X	X	X	X	X	X	X	X	X	X	X	X	X	X
1000	NA	NA	X	X	X	X	X	NA	NA	X	X	X	X	X
1200	NA	NA	X	X	X	X	X	NA	NA	X	X	X	X	X

- PVC Polyvinyl Chloride (PVC) Pipe
- CPVC Corrugated Polyvinyl Chloride (PVC) Pipe with a Smooth Interior
- PVCPW-794 Polyvinyl Chloride (PVC) Profile Wall Pipe-794
- PVCPW-304 Polyvinyl Chloride (PVC) Profile Wall Pipe-304
- PE Polyethylene (PE) Pipe with a Smooth Interior
- CPE Corrugated Polyethylene (PE) Pipe with a Smooth Interior
- PEPW Polyethylene (PE) Profile Wall Pipe
- X This material may be used for the given pipe diameter and fill height.
- NA This material is Not Acceptable for the given pipe diameter and fill height.
- * May be used if Bureau of Materials and Physical Research approves and with manufacturer's certification.

PIPE CULVERT TABLE IIIB											
PLASTIC PIPE PERMITTED FOR A GIVEN PIPE DIAMETER AND FILL HEIGHT OVER THE TOP OF THE PIPE											
Nom. Dia. in.	Type 3 Fill Height: Greater than 10', not exceeding 15'						Type 4 Fill Height: Greater than 15', not exceeding 20'				
	PVC	CPVC	PVCPW -794	PVCPW -304	PE	PEPW	PVC	CPVC	PVCPW -794	PVCPW -304	
10	X	*	NA	NA	X	NA	X	*	NA	NA	
12	X	X	X	X	X	NA	X	X	X	X	
15	X	X	X	X	X	NA	X	X	X	X	
18	X	X	X	X	X	X	X	X	X	X	
21	X	X	X	X	NA	X	X	X	X	X	
24	X	X	X	X	X	X	X	X	X	X	
30	X	X	X	X	X	X	X	X	X	X	
36	X	X	X	X	X	X	X	X	X	X	
42	NA	NA	X	X	X	X	NA	NA	X	X	
48	NA	NA	X	X	X	X	NA	NA	X	X	

PIPE CULVERT TABLE IIIB (metric)											
PLASTIC PIPE PERMITTED FOR A GIVEN PIPE DIAMETER AND FILL HEIGHT OVER THE TOP OF THE PIPE											
Nom. Dia. mm	Type 3 Fill Height: Greater than 3 m, not exceeding 4.5 m						Type 4 Fill Height: Greater than 4.5 m, not exceeding 6 m				
	PVC	CPVC	PVCPW -794	PVCPW -304	PE	PEPW	PVC	CPVC	PVCPW -794	PVCPW -304	
250	X	*	NA	NA	X	NA	X	*	NA	NA	
300	X	X	X	X	X	NA	X	X	X	X	
375	X	X	X	X	X	NA	X	X	X	X	
450	X	X	X	X	X	X	X	X	X	X	
525	X	X	X	X	NA	X	X	X	X	X	
600	X	X	X	X	X	X	X	X	X	X	
750	X	X	X	X	X	X	X	X	X	X	
900	X	X	X	X	X	X	X	X	X	X	
1000	NA	NA	X	X	X	X	NA	NA	X	X	
1200	NA	NA	X	X	X	X	NA	NA	X	X	

- PVC Polyvinyl Chloride (PVC) Pipe
- CPVC Corrugated Polyvinyl Chloride (PVC) Pipe with a Smooth Interior
- PVCPW-794 Polyvinyl Chloride (PVC) Profile Wall Pipe-794
- PVCPW-304 Polyvinyl Chloride (PVC) Profile Wall Pipe-304
- PE Polyethylene (PE) Pipe with a Smooth Interior
- PEPW Polyethylene (PE) Profile Wall Pipe
- X This material may be used for the given pipe diameter and fill height.
- NA This material is Not Acceptable for the given pipe diameter and fill height.
- * May be used if Bureau of Materials and Physical Research approves and with manufacturer's certification.

PIPE CULVERT TABLE IIIC PLASTIC PIPE PERMITTED FOR A GIVEN PIPE DIAMETER AND FILL HEIGHT OVER THE TOP OF THE PIPE										
Nom. Dia. in.	Type 5 Fill Height: Greater Than 20', not exceeding 25'				Type 6 Fill Height: Greater than 25', not exceeding 30'				Type 7 Fill Height: Greater than 30', not exceeding 35'	
	PVC	CPVC	PVCPW -794	PVCPW -304	PVC	CPVC	PVCPW -794	PVCPW -304	PVC	
10	X	*	NA	NA	X	*	NA	NA	X	
12	X	X	X	X	X	X	X	X	X	
15	X	X	X	X	X	NA	NA	NA	X	
18	X	X	X	X	X	NA	NA	NA	X	
21	X	X	X	X	X	NA	NA	NA	X	
24	X	X	X	X	X	NA	NA	NA	X	
30	X	NA	NA	NA	X	NA	NA	NA	X	
36	X	NA	NA	NA	X	NA	NA	NA	X	
42	NA	NA	NA	NA	NA	NA	NA	NA	NA	
48	NA	NA	NA	NA	NA	NA	NA	NA	NA	

PIPE CULVERT TABLE IIIC (metric) PLASTIC PIPE PERMITTED FOR A GIVEN PIPE DIAMETER AND FILL HEIGHT OVER THE TOP OF THE PIPE										
Nom. Dia. mm	Type 5 Fill Height: Greater Than 6 m, not exceeding 7.5 m				Type 6 Fill Height: Greater Than 7.5 m, not exceeding 9 m				Type 7 Fill Height: Greater Than 9 m, not exceeding 10.5 m	
	PVC	CPVC	PVCPW -794	PVCPW -304	PVC	CPVC	PVCPW -794	PVCPW -304	PVC	
250	X	*	NA	NA	X	*	NA	NA	X	
300	X	X	X	X	X	X	X	X	X	
375	X	X	X	X	X	NA	NA	NA	X	
450	X	X	X	X	X	NA	NA	NA	X	
525	X	X	X	X	X	NA	NA	NA	X	
600	X	X	X	X	X	NA	NA	NA	X	
750	X	NA	NA	NA	X	NA	NA	NA	X	
900	X	NA	NA	NA	X	NA	NA	NA	X	
1000	NA	NA	NA	NA	NA	NA	NA	NA	NA	
1200	NA	NA	NA	NA	NA	NA	NA	NA	NA	

- PVC Polyvinyl Chloride (PVC) Pipe
- CPVC Corrugated Polyvinyl Chloride (PVC) Pipe with a Smooth Interior
- PVCPW-794 Polyvinyl Chloride (PVC) Profile Wall Pipe-794
- PVCPW-304 Polyvinyl Chloride (PVC) Profile Wall Pipe-304
- X This material may be used for the given pipe diameter and fill height.
- NA This material is Not Acceptable for the given pipe diameter and fill height.
- * May be used if Bureau of Materials and Physical Research approves and with manufacturer's certification."

Add the following paragraph to the end of Article 542.04(d) of the Standard Specifications:

“PVC and PE pipes shall be joined according to the manufacturer’s specifications.”

Revise the second paragraph of Article 542.04(f) of the Standard Specifications to read:

“When using flexible pipe, as listed in the first table of Article 542.03, the aggregate shall be continued to a height of at least 1 ft (300 mm) above the top of the pipe and compacted to a minimum of 95 percent of standard lab density by mechanical means.”

Revise the first paragraph of Article 542.04(i) of the Standard Specifications to read:

- “(i) Deflection Testing for Pipe Culverts. All PE and PVC pipe culverts shall be tested for deflection not less than 30 days after the pipe is installed and the backfill compacted. The testing shall be performed in the presence of the Engineer.”

Revise the ninth paragraph of Article 542.11 of the Standard Specifications to read:

“End sections for polyvinylchloride (PVC) and polyethylene (PE) culvert pipes will be paid for at the contract unit price per each for METAL END SECTIONS, of the diameter specified.”

Revise Article 1040.04(b) of the Standard Specifications to read:

- “(b) Corrugated PE Pipe with a Smooth Interior. The pipe shall be according to AASHTO M 294 (nominal size – 12 to 48 in. (300 to 1200 mm)). The pipe shall be Type S or D.”

Revise the first paragraph of Article 1040.04(c) of the Standard Specifications to read:

- “(c) PE Profile Wall Pipe. The pipe shall be according to ASTM F 894 and shall have a minimum ring stiffness constant of 160. The pipe shall also have a minimum cell classification of PE 334433C as defined in ASTM D 3350.”

PORTLAND CEMENT CONCRETE PLANTS (BDE)

Effective: January 1, 2007

Add the following to Article 1020.11(a) of the Standard Specifications.

- “(9) Use of Multiple Plants in the Same Construction Item. The Contractor may simultaneously use central-mixed, truck-mixed, and shrink-mixed concrete from more than one plant, for the same construction item, on the same day, and in the same pour. However, the following criteria shall be met.
- a. Each plant shall use the same cement, finely divided minerals, aggregates, admixtures, and fibers.
 - b. Each plant shall use the same mix design. However, material proportions may be altered slightly in the field to meet slump and air content criteria. Field water adjustments shall not result in a difference that exceeds 0.02 between plants for water/cement ratio. The required cement factor for central-mixed concrete shall be increased to match truck-mixed or shrink-mixed concrete, if the latter two types of mixed concrete are used in the same pour.
 - c. The maximum slump difference between deliveries of concrete shall be 3/4 in. (19 mm) when tested at the jobsite. If the difference is exceeded, but test results are within specification limits, the concrete may be used. The Contractor shall take immediate corrective action and shall test subsequent deliveries of concrete until the slump difference is corrected. For each day, the first three truck loads of delivered concrete from each plant shall be tested for slump by the Contractor.

Thereafter, when a specified test frequency for slump is to be performed, it shall be conducted for each plant at the same time.

- d. The maximum air content difference between deliveries of concrete shall be 1.5 percent when tested at the jobsite. If the difference is exceeded, but test results are within specification limits, the concrete may be used. The Contractor shall take immediate corrective action and shall test subsequent deliveries of concrete until the air content difference is corrected. For each day, the first three truck loads of delivered concrete from each plant shall be tested for air content by the Contractor. Thereafter, when a specified test frequency for air content is to be performed, it shall be conducted for each plant at the same time.
- e. Strength tests shall be performed and taken at the jobsite for each plant. When a specified strength test is to be performed, it shall be conducted for each plant at the same time. The difference between plants for their mean strength shall not exceed 450 psi (3100 kPa) compressive and 80 psi (550 kPa) flexural. The strength standard deviation for each plant shall not exceed 650 psi (4480 kPa) compressive and 110 psi (760 kPa) flexural. The mean and standard deviation requirements shall apply to the test of record. If the strength difference requirements are exceeded, the Contractor shall take corrective action.
- f. The maximum haul time difference between deliveries of concrete shall be 15 minutes. If the difference is exceeded, but haul time is within specification limits, the concrete may be used. The Contractor shall take immediate corrective action and check subsequent deliveries of concrete until the haul time difference is corrected.”

POST CLIPS FOR EXTRUDED ALUMINUM SIGNS (BDE)

Effective: January 1, 2009

Revise the sixth paragraph of Article 1090.03 of the Standard Specifications to read:

“Stainless steel post clips shall be according to ASTM A 276, Type 304. In place of stainless steel post clips the manufacturer may substitute aluminum post clips according to ASTM B 108, 356-T6. A flat washer shall be used under each nut to prevent gouging of the clip.”

PRECAST CONCRETE HANDLING HOLES (BDE)

Effective: January 1, 2007

Add the following to Article 540.02 of the Standard Specifications:

“(g) Handling Hole Plugs 1042.16”

Add the following paragraph after the sixth paragraph of Article 540.06 of the Standard Specifications:

“Handling holes shall be filled with a precast concrete plug and sealed with mastic or mortar, or filled with a polyethylene plug. The plug shall not project beyond the inside surface after installation. When metal lifting inserts are used, their sockets shall be filled with mastic or mortar.”

Add the following to Article 542.02 of the Standard Specifications:

“(ee) Handling Hole Plugs 1042.16”

Revise the fifth paragraph of Article 542.04(d) of the Standard Specifications to read:

“Handling holes in concrete pipe shall be filled with a precast concrete plug and sealed with mastic or mortar; or filled with a polyethylene plug. The plug shall not project beyond the inside surface after installation.”

Add the following to Article 550.02 of the Standard Specifications:

“(o) Handling Hole Plugs 1042.16”

Replace the fourth sentence of the fifth paragraph of Article 550.06 of the Standard Specifications with the following:

“Handling holes in concrete pipe shall be filled with a precast concrete plug and sealed with mastic or mortar; or filled with a polyethylene plug. The plug shall not project beyond the inside surface after installation.”

Add the following to Article 602.02 of the Standard Specifications:

“(p) Handling Hole Plugs 1042.16(a)”

Replace the fifth sentence of the first paragraph of Article 602.07 of the Standard Specifications with the following:

“Handling holes shall be filled with a precast concrete plug and sealed with mastic or mortar. The plug shall not project beyond the inside surface after installation. When metal lifting inserts are used, their sockets shall be filled with mastic or mortar.”

Add the following to Section 1042 of the Standard Specifications:

“**1042.16 Handling Hole Plugs.** Plugs for handling holes in precast concrete products shall be as follows.

- (a) Precast Concrete Plug. The precast concrete plug shall have a tapered shape and shall have a minimum compressive strength of 3000 psi (20,700 kPa) at 28 days.
- (b) Polyethylene Plug. The polyethylene plug shall have a “mushroom” shape with a flat round top and a stem with three different size ribs. The plug shall fit snugly and cover the handling hole.

The plug shall be according to the following.

Mechanical Properties	Test Method	Value (min.)
Flexural Modulus	ASTM D 790	3300 psi (22,750 kPa)
Tensile Strength (Break)	ASTM D 638	1600 psi (11,030 kPa)
Tensile Strength (Yield)	ASTM D 638	1200 psi (8270 kPa)

Thermal Properties	Test Method	Value (min.)
Brittle Temperature	ASTM D 746	-49 °F (-45 °C)
Vicat Softening Point	ASTM D 1525	194 °F (90 °C)"

RAISED REFLECTIVE PAVEMENT MARKERS (BDE)

Effective: November 1, 2009

Revised: April 1, 2010

Revise the first sentence of the second paragraph of Article 781.03(a) of the Standard Specifications to read:

“The pavement shall be cut to match the bottom contour of the marker using a concrete saw fitted with 18 and 20 in. (450 and 500 mm) diameter blades.”

RAMP CLOSURE FOR FREEWAY/EXPRESSWAY (BDE)

Effective: January 1, 2009

Description. This work shall consist of furnishing and installing traffic control for the closure of ramps on a freeway/expressway. Work shall be according to Section 701 except as modified herein.

Delete the third paragraph of Article 701.17(e)(1) of the Standard Specifications.

Add the following to Article 701.18 of the Standard Specifications:

“(k) Standard 701451. Only one interchange at a time may have ramps closed and only one exit ramp and one entrance ramp may be closed at a time.

The Contractor shall furnish a portable changeable message sign to be placed on the mainline in advance of the ramp closure. The exact placement and display shall be as shown in the plans or as directed by the Engineer.”

Revise the first sentence of Article 701.19(c) of the Standard Specifications to read:

“Traffic control and protection required under Standards 701201, 701206, 701306, 701326, 701336, 701406, 701421, 701451, 701501, 701502, 701601, 701602, 701606, 701701 and 701801 will be measured for payment on a lump sum basis.”

Add the following to the first paragraph of Article 701.20(b) of the Standard Specifications:

“TRAFFIC CONTROL AND PROTECTION STANDARD 701451;”

RECLAIMED ASPHALT PAVEMENT (RAP) (BDE)

Effective: January 1, 2007

Revised: January 1, 2010

In Article 1030.02(g), delete the last sentence of the first paragraph in (Note 2).

Revise Section 1031 of the Standard Specifications to read:

“SECTION 1031. RECLAIMED ASPHALT PAVEMENT

1031.01 Description. Reclaimed asphalt pavement (RAP) is reclaimed asphalt pavement resulting from cold milling or crushing of an existing dense graded hot-mix asphalt (HMA) pavement. The Contractor shall supply written documentation that the RAP originated from routes or airfields under federal, state, or local agency jurisdiction.

1031.02 Stockpiles. The Contractor shall construct individual, sealed RAP stockpiles meeting one of the following definitions. No additional RAP shall be added to the pile after the pile has been sealed. Stockpiles shall be sufficiently separated to prevent intermingling at the base. Stockpiles shall be identified by signs indicating the type as listed below (i.e. “Homogeneous Surface”).

Prior to milling, the Contractor shall request the District to provide verification of the quality of the RAP to clarify appropriate stockpile.

- (a) Fractionated RAP (FRAP). FRAP shall consist of RAP from Class I, Superpave (High ESAL), HMA (High ESAL), or equivalent mixtures. The coarse aggregate in FRAP shall be crushed aggregate and may represent more than one aggregate type and/or quality but shall be at least C quality. All FRAP shall be fractionated prior to testing by screening into a minimum of two size fractions with the separation occurring on or between the #4 (4.75 mm) and 1/2 in. (12.5 mm) sieves. Agglomerations shall be minimized such that 100 percent of the RAP in the coarse fraction shall pass one sieve size larger than the maximum sieve size specified for the mix the RAP will be used in.
- (b) Homogeneous. Homogeneous RAP stockpiles shall consist of RAP from Class I, Superpave (High ESAL), HMA (High ESAL), or equivalent mixtures and represent: 1) the same aggregate quality, but shall be at least C quality; 2) the same type of crushed aggregate (either crushed natural aggregate, ACBF slag, or steel slag); 3) similar gradation; and 4) similar asphalt binder content. If approved by the Engineer, combined single pass surface/binder millings may be considered “homogenous” with a quality rating dictated by the lowest coarse aggregate quality present in the mixture.
- (c) Conglomerate. Conglomerate RAP stockpiles shall consist of RAP from Class I, Superpave (High ESAL), HMA (High ESAL), or equivalent mixtures. The coarse aggregate in this RAP shall be crushed aggregate and may represent more than one aggregate type and/or quality but shall be at least C quality.

This RAP may have an inconsistent gradation and/or asphalt binder content prior to processing. All conglomerate RAP shall be processed prior to testing by crushing to where all RAP shall pass the 5/8 in. (16 mm) or smaller screen. Conglomerate RAP stockpiles shall not contain steel slag or other expansive material as determined by the Department.

- (d) Conglomerate "D" Quality (DQ). Conglomerate DQ RAP stockpiles shall consist of RAP from Class I, Superpave (High or Low ESAL), HMA (High or Low ESAL), or equivalent mixtures. The coarse aggregate in this RAP may be crushed or round but shall be at least D quality. This RAP may have an inconsistent gradation and/or asphalt binder content. Conglomerate DQ RAP stockpiles shall not contain steel slag or other expansive material as determined by the Department.
- (e) Non-Quality. RAP stockpiles that do not meet the requirements of the stockpile categories listed above shall be classified as "Non-Quality".

RAP/FRAP containing contaminants, such as earth, brick, sand, concrete, sheet asphalt, bituminous surface treatment (i.e. chip seal), pavement fabric, joint sealants, etc., will be unacceptable unless the contaminants are removed to the satisfaction of the Engineer. Sheet asphalt shall be stockpiled separately.

1031.03 Testing. When used in HMA, the RAP/FRAP shall be sampled and tested either during or after stockpiling.

For testing during stockpiling, washed extraction samples shall be run at the minimum frequency of one sample per 500 tons (450 metric tons) for the first 2000 tons (1800 metric tons) and one sample per 2000 tons (1800 metric tons) thereafter. A minimum of five tests shall be required for stockpiles less than 4000 tons (3600 metric tons).

For testing after stockpiling, the Contractor shall submit a plan for approval to the District proposing a satisfactory method of sampling and testing the RAP/FRAP pile either in-situ or by restockpiling. The sampling plan shall meet the minimum frequency required above and detail the procedure used to obtain representative samples throughout the pile for testing.

Before extraction, each field sample shall be split to obtain two samples of test sample size. One of the two test samples from the final split shall be labeled and stored for Department use. The Contractor shall extract the other test sample according to Department procedure. The Engineer reserves the right to test any sample (split or Department-taken) to verify Contractor test results.

Evaluation of Test Results. All of the extraction results shall be compiled and averaged for asphalt binder content and gradation and, when applicable G_{mm} . Individual extraction test results, when compared to the averages, will be accepted if within the tolerances listed below.

Parameter	FRAP/Homogeneous /Conglomerate	Conglomerate "D" Quality
1 in. (25 mm)		± 5 %
1/2 in. (12.5 mm)	± 8 %	± 15 %
No. 4 (4.75 mm)	± 6 %	± 13 %
No. 8 (2.36 mm)	± 5 %	
No. 16 (1.18 mm)		± 15 %
No. 30 (600 μm)	± 5 %	
No. 200 (75 μm)	± 2.0 %	± 4.0 %
Asphalt Binder	± 0.4 % ^{1/}	± 0.5 %
G _{mm}	± 0.03	

1/ The tolerance for FRAP shall be ± 0.3 %.

If more than 20 percent of the individual sieves are out of the gradation tolerances, or if more than 20 percent of the asphalt binder content test results fall outside the appropriate tolerances, the RAP/FRAP shall not be used in HMA unless the RAP/FRAP representing the failing tests is removed from the stockpile. All test data and acceptance ranges shall be sent to the District for evaluation.

With the approval of the Engineer, the ignition oven may be substituted for extractions according to the Illinois Test Procedure, "Calibration of the Ignition Oven for the Purpose of Characterizing Reclaimed Asphalt Pavement (RAP)".

1031.04 Quality Designation of Aggregate in RAP/FRAP.

- (a) The aggregate quality of the RAP for homogenous, conglomerate, and conglomerate "D" quality stockpiles shall be set by the lowest quality of coarse aggregate in the RAP stockpile and are designated as follows.
- (1) RAP from Class I, Superpave (High ESAL)/HMA (High ESAL), or HMA (Low ESAL) IL-9.5L surface mixtures are designated as containing Class B quality coarse aggregate.
 - (2) RAP from Superpave (Low ESAL)/HMA (Low ESAL) IL-19.0L binder mixture is designated as Class D quality coarse aggregate.
 - (3) RAP from Class I, Superpave (High ESAL), or HMA (High ESAL) binder mixtures, bituminous base course mixtures, and bituminous base course widening mixtures are designated as containing Class C quality coarse aggregate.
 - (4) RAP from bituminous stabilized subbase and BAM shoulders are designated as containing Class D quality coarse aggregate.
- (b) The aggregate quality of FRAP shall be determined as follows.

Fractionated stockpiles containing plus #4 (4.75 mm) sieve coarse aggregate shall have a maximum tonnage of 5000 tons (4500 metric tons). The Contractor shall obtain a representative sample witnessed by the Engineer. The sample shall be a minimum of 50 lb (25 kg). The sample shall be extracted according to Illinois Modified AASHTO T 164 by a consultant prequalified by the Department for the specified testing. The consultant shall submit the test results along with the recovered aggregate to the District Office. The cost for this testing shall be paid by the Contractor. The District will forward the sample to the Bmpr Aggregate Lab for MicroDeval Testing, according to Illinois Modified AASHTO T 327. A maximum loss of 15.0 percent will be applied for all HMA applications.”

1031.05 Use of RAP/FRAP in HMA. The use of RAP/FRAP shall be a Contractor’s option when constructing HMA in all contracts. The use of RAP/FRAP in HMA shall be as follows.

- (a) Coarse Aggregate Size. The coarse aggregate in all RAP shall be equal to or less than the nominal maximum size requirement for the HMA mixture to be produced.
- (b) Steel Slag Stockpiles. RAP stockpiles containing steel slag or other expansive material, as determined by the Department, shall be homogeneous and will be approved for use in HMA (High ESAL and Low ESAL) surface mixtures only.
- (c) Use in HMA Surface Mixtures (High and Low ESAL). RAP/FRAP stockpiles for use in HMA surface mixtures (High and Low ESAL) shall be FRAP or homogeneous in which the coarse aggregate is Class B quality or better.
- (d) Use in HMA Binder Mixtures (High and Low ESAL), HMA Base Course, and HMA Base Course Widening. RAP/FRAP stockpiles for use in HMA binder mixtures (High and Low ESAL), HMA base course, and HMA base course widening shall be FRAP, homogeneous, or conglomerate, in which the coarse aggregate is Class C quality or better.
- (e) Use in Shoulders and Subbase. RAP/FRAP stockpiles for use in HMA shoulders and stabilized subbase (HMA) shall be FRAP, homogeneous, conglomerate, or conglomerate DQ.
- (f) When the Contractor chooses the RAP option, the percentage of RAP shall not exceed the amounts indicated in the table below for a given N Design.

Max RAP Percentage

HMA Mixtures ^{1/, 3/}	Maximum % RAP		
	Binder/Leveling Binder	Surface	Polymer Modified
30	30	30	10
50	25	15	10
70	15 / 25 ^{2/}	10 / 15 ^{2/}	10
90	10	10	10
105	10	10	10

- 1/ For HMA shoulder and stabilized subbase (HMA) N-30, the amount of RAP shall not exceed 50% of the mixture.
- 2/ Value of Max % RAP if homogeneous RAP stockpile of IL-9.5 RAP is utilized.
- 3/ When RAP exceeds 20 percent, the high and low virgin asphalt binder grades shall each be reduced by one grade (i.e. 25 percent RAP would require a virgin asphalt binder grade of PG64-22 to be reduced to a PG58-28). If warm mix asphalt (WMA) technology is utilized, and production temperatures do not exceed 275°F (135 °C) the grades shall be reduced as follows:

Overlays:

When WMA contains between 20 and 30 percent RAP the high temperature shall be reduced by one grade (i.e. 25 percent RAP would require a virgin asphalt binder grade of PG64-22 to be reduced to a PG58-22). When WMA contains 30 percent or more RAP the high and low temperature grades shall each be reduced by one grade (i.e. 35 percent RAP would require a virgin asphalt binder grade of PG64-22 to be reduced to a PG58-28).

Full Depth:

When WMA contains between 20 and 30 percent RAP, the low temperature shall be reduced by one grade (i.e. 25 percent RAP would require a virgin asphalt binder grade of PG64-22 to be reduced to a PG64-28). When the WMA contains 30 percent or more RAP the high and low temperature grades shall each be reduced by one grade (i.e. 35 percent RAP would require a virgin asphalt binder grade of PG64-22 to be reduced to a PG58-28).

- (g) When the Contractor chooses the FRAP option, the percentage of FRAP shall not exceed the amounts indicated in the table below for a given N Design.

Max FRAP Percentage

HMA Mixtures ^{1/, 2/}	Maximum % FRAP		
	Ndesign	Binder/Leveling Binder	Surface
30	35	35	10
50	30	25	10
70	25	20	10
90	20	15	10
105	10	10	10

- 1/ For HMA shoulder and stabilized subbase (HMA) N30, the amount of FRAP shall not exceed 50 percent of the mixture.
- 2/ When FRAP exceeds 20 percent, the high and low virgin asphalt binder grades shall each be reduced by one grade (i.e. 25 percent FRAP would require a virgin asphalt binder grade of PG64-22 to be reduced to a PG58-28). If warm mix asphalt (WMA) technology is utilized, and production temperatures do not exceed 275°F (135 °C) the grades shall be reduced as follows:

Overlays:

When WMA contains between 20 and 30 percent FRAP the high temperature shall be reduced by one grade (i.e. 25 percent FRAP would require a virgin asphalt binder grade of PG64-22 to be reduced to a PG58-22). When WMA contains 30 percent or more FRAP the high and low temperature grades shall each be reduced by one grade (i.e. 35 percent FRAP would require a virgin asphalt binder grade of PG64-22 to be reduced to a PG58-28).

Full Depth:

When WMA contains between 20 and 30 percent FRAP, the low temperature shall be reduced by one grade (i.e. 25 percent FRAP would require a virgin asphalt binder grade of PG64-22 to be reduced to a PG64-28). When the WMA contains 30 percent or more FRAP the high and low temperature grades shall each be reduced by one grade (i.e. 35 percent FRAP would require a virgin asphalt binder grade of PG64-22 to be reduced to a PG58-28).

1031.06 HMA Mix Designs. At the Contractor's option, HMA mixtures may be constructed utilizing RAP/FRAP material meeting the above detailed requirements.

RAP/FRAP designs shall be submitted for volumetric verification. If additional RAP/FRAP stockpiles are tested and found that no more than 20 percent of the results, as defined under "Testing" herein, are outside of the control tolerances set for the original RAP/FRAP stockpile and HMA mix design, and meets all of the requirements herein, the additional RAP/FRAP stockpiles may be used in the original mix design at the percent previously verified.

1031.07 HMA Production. The coarse aggregate in all RAP used shall be equal to or less than the nominal maximum size requirement for the HMA mixture being produced.

To remove or reduce agglomerated material, a scalping screen, gator, crushing unit, or comparable sizing device approved by the Engineer shall be used in the RAP feed system to remove or reduce oversized material. If material passing the sizing device adversely affects the mix production or quality of the mix, the sizing device shall be set at a size specified by the Engineer.

If the RAP/FRAP control tolerances or QC/QA test results require corrective action, the Contractor shall cease production of the mixture containing RAP/FRAP and either switch to the virgin aggregate design or submit a new RAP/FRAP design.

HMA plants utilizing RAP/FRAP shall be capable of automatically recording and printing the following information.

(a) Dryer Drum Plants.

- (1) Date, month, year, and time to the nearest minute for each print.
- (2) HMA mix number assigned by the Department.
- (3) Accumulated weight of dry aggregate (combined or individual) in tons (metric tons) to the nearest 0.1 ton (0.1 metric ton).

- (4) Accumulated dry weight of RAP/FRAP in tons (metric tons) to the nearest 0.1 ton (0.1 metric ton).
- (5) Accumulated mineral filler in revolutions, tons (metric tons), etc. to the nearest 0.1 unit.
- (6) Accumulated asphalt binder in gallons (liters), tons (metric tons), etc. to the nearest 0.1 unit.
- (7) Residual asphalt binder in the RAP/FRAP material as a percent of the total mix to the nearest 0.1 percent.
- (8) Aggregate and RAP/FRAP moisture compensators in percent as set on the control panel. (Required when accumulated or individual aggregate and RAP/FRAP are printed in wet condition.)

(b) Batch Plants.

- (1) Date, month, year, and time to the nearest minute for each print.
- (2) HMA mix number assigned by the Department.
- (3) Individual virgin aggregate hot bin batch weights to the nearest pound (kilogram).
- (4) Mineral filler weight to the nearest pound (kilogram).
- (5) RAP/FRAP weight to the nearest pound (kilogram).
- (6) Virgin asphalt binder weight to the nearest pound (kilogram).
- (7) Residual asphalt binder in the RAP/FRAP material as a percent of the total mix to the nearest 0.1 percent.

The printouts shall be maintained in a file at the plant for a minimum of one year or as directed by the Engineer and shall be made available upon request. The printing system will be inspected by the Engineer prior to production and verified at the beginning of each construction season thereafter.

1031.08 RAP in Aggregate Surface Course and Aggregate Shoulders. The use of RAP in aggregate surface course and aggregate shoulders shall be as follows.

- (a) Stockpiles and Testing. RAP stockpiles may be any of those listed in Article 1031.02, except "Non-Quality" and "FRAP". The testing requirements of Article 1031.03 shall not apply.
- (b) Gradation. One hundred percent of the RAP material shall pass the 1 1/2 in. (37.5 mm) sieve. The RAP material shall be reasonably well graded from coarse to fine. RAP material that is gap-graded or single sized will not be accepted."

REFLECTIVE SHEETING ON CHANNELIZING DEVICES (BDE)

Effective: April 1, 2007

Revised: November 1, 2008

Revise the seventh paragraph of Article 1106.02 of the Standard Specifications to read:

“At the time of manufacturing, the retroreflective prismatic sheeting used on channelizing devices shall meet or exceed the initial minimum coefficient of retroreflection as specified in the following table. Measurements shall be conducted according to ASTM E 810, without averaging. Sheeting used on cones, drums and flexible delineators shall be reboundable as tested according to ASTM D 4956. Prestriped sheeting for rigid substrates on barricades shall be white and orange. **The sheeting shall be uniform in color and devoid of streaks throughout the length of each roll. The color shall conform to the latest appropriate standard color tolerance chart issued by the U.S. Department of Transportation, Federal Highway Administration, and to the daytime and nighttime color requirements of ASTM D 4956.**

Initial Minimum Coefficient of Retroreflection candelas/foot candle/sq ft (candelas/lux/sq m) of material				
Observation Angle (deg.)	Entrance Angle (deg.)	White	Orange	Fluorescent Orange
0.2	-4	365	160	150
0.2	+30	175	80	70
0.5	-4	245	100	95
0.5	+30	100	50	40”

Revise the first sentence of the first paragraph of Article 1106.02(c) of the Standard Specifications to read:

“Barricades and vertical panels shall have alternating white and orange stripes sloping downward at 45 degrees toward the side on which traffic will pass.”

Revise the third sentence of the first paragraph of Article 1106.02(d) of the Standard Specifications to read:

“The bottom panels shall be 8 x 24 in. (200 x 600 mm) with alternating white and orange stripes sloping downward at 45 degrees toward the side on which traffic will pass.”

REINFORCEMENT BARS - STORAGE AND PROTECTION (BDE)

Effective: August 1, 2008

Revised: April 1, 2009

Revise Article 508.03 of the Standard Specifications to read:

“508.03 Storage and Protection. Reinforcement bars shall be stored off the ground using platforms, skids, or other supports; and shall be protected from mechanical injury and from deterioration by exposure. Epoxy coated bars shall be stored on wooden or padded steel cribbing and all systems for handling shall have padded contact areas. The bars or bundles shall not be dragged or dropped.

When epoxy coated bars are stored in a manner where they will be exposed to the weather more than 60 days prior to use, they shall be protected from deterioration such as that caused by sunlight, salt spray, and weather exposure. The protection shall consist of covering with opaque polyethylene sheeting or other suitable opaque material. The covering shall be secured and allow for air circulation around the bars to minimize condensation under the cover.

Covering of the epoxy coated bars will not be required when the bars are installed and tied, or when they are partially incorporated into the concrete.”

SEEDING (BDE)

Effective: July 1, 2004

Revised: July 1, 2010

Revise the following seeding mixtures shown in Table 1 of Article 250.07 of the Standard Specifications to read:

"Table 1 - SEEDING MIXTURES		
Class – Type	Seeds	lb/acre (kg/hectare)
1A Salt Tolerant Lawn Mixture 7/	Bluegrass Perennial Ryegrass Red Fescue (Audubon, Sea Link, or Epic) Hard Fescue (Rescue 911, Spartan II, or Reliant IV) Fulfs Salt Grass 1/ or Salty Alkaligrass	60 (70) 20 (20) 20 (20) 20 (20) 60 (70)
2 Roadside Mixture 7/	Tall Fescue (Inferno, Tarheel II, Quest, Blade Runner, or Falcon IV) Perennial Ryegrass Creeping Red Fescue Red Top	100 (110) 50 (55) 40 (50) 10 (10)
2A Salt Tolerant Roadside Mixture 7/	Tall Fescue (Inferno, Tarheel II, Quest, Blade Runner, or Falcon IV) Perennial Ryegrass Red Fescue (Audubon, Sea Link, or Epic) Hard Fescue (Rescue 911, Spartan II, or Reliant IV) Fulfs Salt Grass 1/ or Salty Alkaligrass	60 (70) 20 (20) 30 (20) 30 (20) 60 (70)
3 Northern Illinois Slope Mixture 7/	Elymus Canadensis (Canada Wild Rye) Perennial Ryegrass Alsike Cover 2/ Desmanthus Illinoensis (Illinois Bundleflower) 2/, 5/ Andropogon Scoparius (Little Bluestem) 5/ Bouteloua Curtipendula (Side-Oats Grama) Fulfs Salt Grass 1/ or Salty Alkaligrass Oats, Spring Slender Wheat Grass 5/ Buffalo Grass (Cody or Bowie) 4/, 5/, 9/	5 (5) 20 (20) 5 (5) 2 (2) 12 (12) 10 (10) 30 (35) 50 (55) 15 (15) 5 (5)

"Table 1 - SEEDING MIXTURES			
6A	Salt Tolerant Conservation Mixture	Andropogon Scoparius (Little Bluestem) 5/	5 (5)
		Elymus Canadensis (Canada Wild Rye) 5/	2 (2)
		Buffalo Grass (Cody or Bowie) 4/, 5/, 9/	5 (5)
		Vernal Alfalfa 2/	15 (15)
		Oats, Spring	48 (55)
		Fults Salt Grass 1/ or Salty Alkaligrass	20 (20)"

Revise Note 7 of Table 1 – Seeding Mixtures of Article 250.07 of the Standard Specifications to read:

“7/ In Districts 1 through 6, the planting times shall be April 1 to June 15 and August 1 to November 1. In Districts 7 through 9, the planting times shall be March 1 to June 1 and August 1 to November 15. Seeding may be performed outside these dates provided the Contractor guarantees a minimum of 75 percent uniform growth over the entire seeded area(s) after a period of establishment. Inspection dates for the period of establishment will be as follows: Seeding conducted in Districts 1 through 6 between June 16 and July 31 will be inspected after April 15 and seeding conducted between November 2 and March 31 will be inspected after September 15. Seeding conducted in Districts 7 through 9 between June 2 and July 31 will be inspected after April 15 and seeding conducted between November 16 and February 28 will be inspected after September 15. The guarantee shall be submitted to the Engineer in writing prior to performing the work. After the period of establishment, areas not exhibiting 75 percent uniform growth shall be interseeded or reseeded, as determined by the Engineer, at no additional cost to the Department.”

Revise the first paragraph of Article 1081.04(a) of the Standard Specifications to read:

“(a) Sampling and Testing. Each lot of seed furnished shall be tested by a State Agriculture Department (including other States) or by land grant college or university agricultural sections or by a Registered Seed Technologist. Germination testing of seed shall be accomplished within the 12 months prior to the seed being installed on the project.”

Delete the last sentence of the first paragraph of Article 1081.04(c)(2) of the Standard Specifications.

Revise Table II of Article 1081.04(c)(6) of the Standard Specifications to read:

TABLE II						
Variety of Seeds	Hard Seed	Purity	Pure Live	Weed	Secondary *	Notes
	% Max.	% Min.	Seed % Min.	% Max.	Noxious Weeds No. per oz (kg) Max. Permitted	
Alfalfa	20	92	89	0.50	6 (211)	1/
Clover, Alsike	15	92	87	0.30	6 (211)	2/
Red Fescue, Audubon	0	97	82	0.10	3 (105)	-
Red Fescue, Creeping	-	97	82	1.00	6 (211)	-
Red Fescue, Epic	-	98	83	0.05	1 (35)	-
Red Fescue, Sea Link	-	98	83	0.10	3 (105)	-
Tall Fescue, Blade Runner	-	98	83	0.10	2 (70)	-
Tall Fescue, Falcon IV	-	98	83	0.05	1 (35)	-
Tall Fescue, Inferno	0	98	83	0.10	2 (70)	-
Tall Fescue, Tarheel II	-	97	82	1.00	6 (211)	-
Tall Fescue, Quest	0	98	83	0.10	2 (70)	-
Fults Salt Grass	0	98	85	0.10	2 (70)	-
Salty Alkaligrass	0	98	85	0.10	2 (70)	-
Kentucky Bluegrass	-	97	80	0.30	7 (247)	4/
Oats	-	92	88	0.50	2 (70)	3/
Redtop	-	90	78	1.80	5 (175)	3/
Ryegrass, Perennial, Annual	-	97	85	0.30	5 (175)	3/
Rye, Grain, Winter	-	92	83	0.50	2 (70)	3/
Hard Fescue, Reliant IV	-	98	83	0.05	1 (35)	-
Hard Fescue, Rescue 911	0	97	82	0.10	3 (105)	-
Hard Fescue, Spartan II	-	98	83	0.10	3 (105)	-
Timothy	-	92	84	0.50	5 (175)	3/
Wheat, hard Red Winter	-	92	89	0.50	2 (70)	3/

Revise the first sentence of the first paragraph of Article 1081.04(c)(7) of the Standard Specifications to read:

“The seed quantities indicated per acre (hectare) for Prairie Grass Seed in Classes 3, 3A, 4, 4A, 6, and 6A in Article 250.07 shall be the amounts of pure, live seed per acre (hectare) for each species listed.”

SELF-CONSOLIDATING CONCRETE FOR PRECAST PRODUCTS (BDE)

Effective: July 1, 2004

Revised: July 1, 2010

Definition. Self-consolidating concrete is a flowable mixture that does not require mechanical vibration for consolidation.

Usage. Self-consolidating concrete may be used for precast concrete products.

Materials. Materials shall be according to Section 1021 of the Standard Specifications.

Mix Design Criteria. The mix design criteria shall be as follows:

- (a) The minimum cement factor shall be according to Article 1020.04 of the Standard Specifications. If the maximum cement factor is not specified, it shall not exceed 7.05 cwt/cu yd (418 kg/cu m).

- (b) The maximum allowable water/cement ratio shall be according to Article 1020.04 of the Standard Specifications or 0.44, whichever is lower.
- (c) The slump requirements of Article 1020.04 of the Standard Specifications shall not apply.
- (d) The coarse aggregate gradations shall be CA 13, CA 14, CA 16, or a blend of these gradations. CA 11 may be used when the Contractor provides satisfactory evidence to the Engineer that the mix will not segregate. The fine aggregate proportion shall be a maximum 50 percent by weight (mass) of the total aggregate used.
- (e) The slump flow range shall be ± 2 in. (± 50 mm) of the Contractor target value, and within the overall Department range of 20 in. (510 mm) minimum to 28 in. (710 mm) maximum.
- (f) The visual stability index shall be a maximum of 1.
- (g) The J-ring value shall be a maximum of 4 in. (100 mm). The Contractor may specify a lower maximum in the mix design.
- (h) The L-box blocking ratio shall be a minimum of 60 percent. The Contractor may specify a higher minimum in the mix design.
- (i) The hardened visual stability index shall be a maximum of 1.

Mixing Portland Cement Concrete. In addition to Article 1020.11 of the Standard Specifications, the mixing time for central-mixed concrete shall not be reduced as a result of a mixer performance test. Truck-mixed or shrink-mixed concrete shall be mixed in a truck mixer for a minimum of 100 revolutions.

Wash water, if used, shall be completely discharged from the drum or container before the succeeding batch is introduced.

The batch sequence, mixing speed, and mixing time shall be appropriate to prevent cement balls and mix foaming for central-mixed, truck-mixed, and shrink-mixed concrete.

Placing and Consolidating. The maximum distance of horizontal flow from the point of deposit shall be 25 ft (7.6 m), unless approved otherwise by the Engineer.

Concrete shall be rodded with a piece of lumber, conduit, or vibrator if the material has lost its fluidity prior to placement of additional concrete. The vibrator shall be the pencil head type with a maximum diameter or width of 1 in. (25 mm). Any other method for restoring the fluidity of the concrete shall be approved by the Engineer.

Mix Design Approval. The Contractor shall obtain mix design approval according to the Department's Policy Memorandum "Quality Control/Quality Assurance Program for Precast Concrete Products".

SUBCONTRACTOR MOBILIZATION PAYMENTS (BDE)

Effective: April 2, 2005

To account for the preparatory work and operations necessary for the movement of subcontractor personnel, equipment, supplies, and incidentals to the project site and for all other work or operations that must be performed or costs incurred when beginning work approved for subcontracting in accordance with Article 108.01 of the Standard Specifications, the Contractor shall make a mobilization payment to each subcontractor.

This mobilization payment shall be made at least 14 days prior to the subcontractor starting work. The amount paid shall be equal to 3 percent of the amount of the subcontract reported on form BC 260A submitted for the approval of the subcontractor's work.

This provision shall be incorporated directly or by reference into each subcontract approved by the Department.

SURFACE TESTING OF PAVEMENTS (BDE)

Effective: April 1, 2002

Revised: January 1, 2007

Hot-Mix Asphalt (HMA) Overlays

Revise Article 406.03(h) of the Standard Specifications to read:

“(h) Pavement Surface Test Equipment 1101.10”

Revise Article 406.11 of the Standard Specifications to read:

“**406.11 Surface Tests.** The finished surface of the pavement shall be tested for smoothness within three days of paving. Testing shall be performed in the presence of the Engineer.

Prior to testing, a copy of the approval letter and recorded settings from the Profile Equipment Verification (PEV) Program shall be submitted to the Engineer; and all objects and debris shall be removed from the pavement.

(a) Test Sections/Equipment.

(1) High-Speed Mainline Pavement. High-speed mainline pavement shall consist of pavements, ramps, and loops with a posted speed greater than 45 mph. These sections shall be tested using a profile testing device.

(2) Low-Speed Mainline Pavement. Low-speed mainline pavement shall consist of pavements, ramps, and loops with a posted speed of 45 mph or less. These sections shall be tested using a profile testing device.

(3) Miscellaneous Pavement. Miscellaneous pavement shall consist of:

- a. pavement on horizontal curves with a centerline radius of curvature of less than or equal to 1000 ft (300 m) and pavement within the superelevation transition of such curves;
- b. pavement on vertical curves having a length of less than or equal to 200 ft (60 m) in combination with an algebraic change in tangent grades greater than or equal to three percent, as may occur on urban ramps or other constricted-space facilities;
- c. the first or last 15 ft (4.5 m) of a pavement section where the Contractor is not responsible for the adjoining surface;
- d. intersections;
- e. variable width pavements;
- f. side street returns;
- g. crossovers;
- h. connector pavement from mainline pavement expansion joint to the bridge approach pavement;
- i. bridge approach pavement; and
- j. other miscellaneous pavement surfaces (i.e. a turn lane) as determined by the Engineer.

Miscellaneous pavement shall be tested using a 16 ft (5 m) straightedge set to a 3/8 in. (10 mm) tolerance.

(b) Lots/Sublots. Mainline pavement test sections will be divided into lots and sublots.

(1) Lots. A lot will be defined as a continuous strip of pavement 1 mile (1600 m) long and one lane wide. When the length of a continuous strip of pavement is less than 1 mile (1600 m), that pavement will be included in an adjacent lot. Structures will be omitted when measuring pavement length.

(2) Sublots. Lots will be divided into 0.1 mile (160 m) sublots. A partial subplot greater than or equal to 250 ft (76 m) resulting from an interruption in the pavement will be subject to the same evaluation as a whole subplot. Partial sublots less than 250 ft (76 m) shall be included with the previous subplot for evaluation purposes.

(c) Testing Procedure. One wheel track shall be tested per lane. Testing shall be performed 3 ft (1 m) from and parallel to the edge of the lane away from traffic. A guide shall be used to maintain the proper distance.

The profile trace generated shall have stationing indicated every 500 ft (150 m) at a minimum. Both ends of the profile trace shall be labeled with the following information: contract number, beginning and ending stationing, which direction is up on the trace, which direction the data was collected, and the device operator name(s). The top portion of the Department supplied form, "Profile Report of Pavement Smoothness" shall be completed and secured around the trace roll.

Although surface testing of intermediate lifts will not be required, they may be performed at the Contractor's option. When this option is chosen, the testing shall be performed and the profile traces shall be generated as described above.

The Engineer may perform his/her own testing at any time for monitoring and comparison purposes.

- (d) Trace Reduction and Bump Locating Procedure. All traces shall be reduced. Traces produced by a mechanical recorder shall be reduced using an electronic scanner and computer software. This software shall calculate the profile index of each subplot in in./mile (mm/km) and indicate any high points (bumps) in excess of 0.30 in. (8 mm) with a line intersecting the profile on the printout. Computerized recorders shall provide the same information.

The profile index of each track, average profile index of each subplot, average profile index of the lot and locations of bumps shall be recorded on the form.

All traces and reports shall be provided within two working days of completing the testing to the Engineer for the project file. Traces from either a computerized profile testing device or analysis software used with a manual profile testing device shall display the settings used for the data reduction. The Engineer will compare these settings with the approved settings from the PEV Program. If the settings do not match, the results will be rejected and the section shall be retested/reanalyzed with the appropriate settings.

The Engineer will use the results of the testing to evaluate paving methods and equipment. If the average profile index of a lot exceeds 40.0 in./mile (635 mm/km) for high-speed mainline pavement or 65.0 in./mile (1025 mm/km) for low-speed mainline pavement, the paving operation will be suspended until corrective action is taken by the Contractor.

- (e) Corrective Work. All bumps in excess of 0.30 in. (8 mm) in a length of 25 ft (8 m) or less shall be corrected. If the bump is greater than 0.50 in. (13 mm), the pavement shall be removed and replaced. The minimum length of pavement to be removed shall be 3 ft (900 mm).
- (1) High-Speed Mainline Pavement. Any subplot having a profile index within the range of, greater than 30.0 to 40.0 in./mile (475 to 635 mm/km) including bumps, shall be corrected to reduce the profile index to 30.0 in./mile (475 mm/km) or less on each trace. Any subplot having a profile index greater than 40.0 in./mile (635 mm/km) including bumps, shall be corrected to reduce the profile index to 30.0 in./mile (475 mm/km) or less on each trace, or replaced at the Contractor's option.

- (2) Low-Speed Mainline Pavement. Any subplot having a profile index within the range of, greater than 45.0 to 65.0 in./mile (710 to 1025 mm/km) including bumps, shall be corrected to reduce the profile index to 45.0 in./mile (710 mm/km) or less on each trace. Any subplot having a profile index greater than 65.0 in./mile (1025 mm/km) including bumps, shall be corrected to reduce the profile index to 45.0 in./mile (710 mm/km) or less on each trace, or replaced at the Contractor's option.
- (3) Miscellaneous Pavement. Surface variations which exceed the 3/8 in. (10 mm) tolerance will be marked by the Engineer and shall be corrected by the Contractor.

Corrective work shall be completed using either an approved grinding device consisting of multiple saws or by removing and replacing the pavement. Corrective work shall be applied to the full lane width. When completed, the corrected area shall have uniform texture and appearance, with the beginning and ending of the corrected area squared normal to the centerline of the paved surface.

Upon completion of the corrective work, the surface of the subplot(s) shall be retested. The Contractor shall furnish the profile tracing(s) and the completed form(s) to the Engineer within two working days after corrections are made. If the profile index and/or bumps still do not meet the requirements, additional corrective work shall be performed.

Corrective work shall be at no additional cost to the Department.

- (f) Smoothness Assessments. Assessments will be paid to or deducted from the Contractor for each subplot of mainline pavement, per the Smoothness Assessment Schedule. Assessments will be based on the average profile index of each subplot prior to performing any corrective work unless the Contractor has chosen to remove and replace the subplot. For sublots that are replaced, assessments will be based on the profile index determined after replacement.

Assessments will not be paid or deducted until all other contract requirements for the pavement are satisfied. Pavement that is corrected or replaced for reasons other than smoothness, shall be retested as stated herein.

SMOOTHNESS ASSESSMENT SCHEDULE (HMA Overlays)		
High-Speed Mainline Pavement Average Profile Index in./mile (mm/km)	Low-Speed Mainline Pavement Average Profile Index in./mile (mm/km)	Assessment per subplot
6.0 (95) or less	15.0 (240) or less	+\$150.00
>6.0 (95) to 10.0 (160)	>15.0 (240) to 25.0 (400)	+\$80.00
>10.0 (160) to 30.0 (475)	>25.0 (400) to 45.0 (710)	+\$0.00
>30.0 (475) to 40.0 (635)	>45.0 (710) to 65.0 (1025)	+\$0.00
Greater than 40.0 (635)	Greater than 65.0 (1025)	-\$300.00

Smoothness assessments will not be applied to miscellaneous pavement sections.”

Hot-Mix Asphalt (HMA) Pavement (Full-Depth)

Revise Article 407.09 of the Standard Specifications to read:

“407.09 Surface Tests. The finished surface of the pavement shall be tested for smoothness according to Article 406.11, except as follows:

Two wheel tracks shall be tested per lane. Testing shall be performed 3 ft (1 m) from and parallel to each lane edge.

SMOOTHNESS ASSESSMENT SCHEDULE (Full-Depth HMA)		
High-Speed Mainline Pavement Average Profile Index in./mile (mm/km)	Low-Speed Mainline Pavement Average Profile Index in./mile (mm/km)	Assessment per subplot
6.0 (95) or less		+\$800.00
>6.0 (95) to 11.0 (175)	15.0 (240) or less	+\$550.00
>11.0 (175) to 17.0 (270)	>15.0 (240) to 25.0 (400)	+\$350.00
>17.0 (270) to 30.0 (475)	>25.0 (400) to 45.0 (710)	+\$0.00
>30.0 (475) to 40.0 (635)	>45.0 (710) to 65.0 (1025)	+\$0.00
Greater than 40.0 (635)	Greater than 65.0 (1025)	-\$500.00”

Delete the third paragraph of Article 407.12 of the Standard Specifications.

Portland Cement Concrete Pavement

Revise Article 420.10 of the Standard Specifications to read:

“420.10 Surface Tests. The finished surface of the pavement shall be tested for smoothness according to Article 406.11, except as follows:

The finished surface of the pavement shall be tested for smoothness once the pavement has attained a flexural strength of 550 psi (3800 kPa) or a compressive strength of 3000 psi (20,700 kPa).

Two wheel tracks shall be tested per lane. Testing shall be performed 3 ft (1 m) from and parallel to each lane edge.

Membrane curing damaged during testing shall be repaired as directed by the Engineer at no additional cost to the Department.

No further texturing for skid resistance will be required for areas corrected by grinding. Protective coat shall be reapplied to ground areas according to Article 420.18 at no additional cost to the Department.

For pavement that is corrected by removal and replacement, the minimum length to be removed shall meet the requirements of either Class A or Class B patching.

SMOOTHNESS ASSESSMENT SCHEDULE (PCC)		
High-Speed Mainline Pavement Average Profile Index in./mile (mm/km)	Low-Speed Mainline Pavement Average Profile Index in./mile (mm/km)	Assessment per subplot
6.0 (95) or less		+\$1200.00
>6.0 (95) to 11.0 (175)	15.0 (240) or less	+\$950.00
>11.0 (175) to 17.0 (270)	>15.0 (240) to 25.0 (400)	+\$600.00
>17.0 (270) to 30.0 (475)	>25.0 (400) to 45.0 (710)	+\$0.00
>30.0 (475) to 40.0 (635)	>45.0 (710) to 65.0 (1025)	+\$0.00
Greater than 40.0 (635)	Greater than 65.0 (1025)	-\$750.00"

Delete the fourth paragraph of Article 420.20 of the Standard Specifications.

Testing Equipment

Revise Article 1101.10 of the Standard Specifications to read:

“1101.10 Pavement Surface Test Equipment. Required surface testing and analysis equipment and their jobsite transportation shall be provided by the Contractor.

- (a) 16 ft (5 m) Straightedge. The 16 ft (5 m) straightedge shall consist of a metal I-beam mounted between two wheels spaced 16 ft (5 m) between the axles. Scratcher bolts which can be easily and accurately adjusted, shall be set at the 1/4, 1/2, and 3/4 points between the axles. A handle suitable for pushing and guiding shall be attached to the straightedge.
- (b) Profile Testing Device. The profile testing device shall have a decal displayed to indicate it has been tested through the Profile Equipment Verification (PEV) Program administered by the Department.
 - (1) California Profilograph. The California Profilograph shall be either computerized or manual and have a frame 25 ft (8 m) in length supported upon multiple wheels at either end. The profile shall be recorded from the vertical movement of a wheel attached to the frame at mid point.

The California Profilograph shall be calibrated according to the manufacturer’s recommendations and California Test 526. All calibration traces and calculations shall be submitted to the Engineer for the project file.

- (2) Inertial Profiler. The inertial profiler shall be either an independent device or a system that can be attached to another vehicle using one or two non-contact sensors to measure the pavement profile. The inertial profiler shall be capable of performing a simulation of the California Profilograph to provide results in the Profile Index format.

The inertial profiler shall be calibrated according to the manufacturer's recommendations. All calibration traces and calculations shall be submitted to the Engineer for the project file.

- (3) Trace Analysis. The Contractor shall reduce/evaluate these traces using a 0.00 in. (0.0 mm) blanking band and determine a Profile Index in in./mile (mm/km) for each section of finished pavement surface. Traces produced using a computerized profile testing device will be evaluated without further reduction. When using a manual profile testing device, the Contractor shall provide an electronic scanner, a computer, and software to reduce the trace. All analysis equipment (electronic scanner, computerized recorder, etc.) shall be able to accept 0.00 in. (0.0 mm) for the blanking band.

All traces from pavement sections tested with the profile testing device shall be recorded on paper with scales of 300:1 longitudinally and 1:1 vertically. Equipment and software settings of the profile testing device and analysis equipment shall be set to those values approved through the PEV Program.

The Engineer may retest the pavement at any time to verify the accuracy of the equipment.”

TEMPORARY EROSION CONTROL (BDE)

Effective: November 1, 2002

Revised: July 1, 2010

Add the following to Article 280.02 of the Standard Specifications to read:

“(k) Filter Fabric 1080.03”

Revise the third paragraph of Article 280.03 of the Standard Specifications to read:

“Erosion control systems shall be installed prior to beginning any activities which will potentially create erodible conditions. Erosion control systems for areas outside the limits of construction such as storage sites, plant sites, waste sites, haul roads, and Contractor furnished borrow sites shall be installed prior to beginning soil disturbing activities at each area. These offsite systems shall be designed by the Contractor and be subject to the approval of the Engineer.”

Add the following paragraph after the third paragraph of Article 280.03 of the Standard Specifications:

“The temporary erosion and sediment control systems shown on the plans represent the minimum systems anticipated for the project. Conditions created by the Contractor's operations, or for the Contractor's convenience, which are not covered by the plans, shall be protected as directed by the Engineer at no additional cost to the Department. Revisions or modifications of the erosion and sediment control systems shall have the Engineer's written approval.”

Revise Article 280.04(a) of the Standard Specifications to read:

“(a) Temporary Ditch Checks. This system consists of the construction of temporary ditch checks to prevent siltation, erosion, or scour of ditches and drainage ways. Temporary ditch checks shall be constructed with rolled excelsior, products from the Department’s approved list, or with aggregate placed on filter fabric when specified. Filter fabric shall be installed according to the requirements of Section 282. Riprap shall be placed according to Article 281.04. Manufactured ditch checks shall be installed according to the manufacturer’s specifications. Spacing of ditch checks shall be such that the low point in the center of one ditch check is at the same elevation as the base of the ditch check immediately upstream. Temporary ditch checks shall be sufficiently long enough that the top of the device in the middle of the ditch is lower than the bottom of the terminating ends of the ditch side slopes.”

Revise the last sentence of the first paragraph of Article 280.04(g) of the Standard Specifications to read:

“The temporary mulch cover shall be according to either Article 251.03 or 251.04 except for any reference to seeding.”

Revise Article 280.07(b) of the Standard Specifications to read:

“(b) Temporary Ditch Checks. This work will be measured for payment along the long axis of the device in place in feet (meters) except for aggregate ditch checks which will be measured for payment in tons (metric tons). Payment will not be made for aggregate in excess of 108 percent of the amount specified by the Engineer.”

Revise Article 280.07(f) of the Standard Specifications to read:

“(f) Temporary Mulch. This work will be measured for payment according to Article 251.05(b).”

Add the following paragraph after the ninth paragraph of Article 280.07 of the Standard Specifications:

“Temporary or permanent erosion control systems required for areas outside the limits of construction will not be measured for payment.”

Revise Article 280.08(b) of the Standard Specifications to read:

“(b) Temporary Ditch Checks. This work will be paid for at the contract unit price per foot (meter) for TEMPORARY DITCH CHECKS except for aggregate ditch checks which will be paid for at the contract unit price per ton (metric ton) for AGGREGATE DITCH CHECKS.”

Revise Article 280.08(f) of the Standard Specifications to read:

“(f) Temporary Mulch. Temporary Mulch will be paid for according to Article 251.06.”

Delete the tenth (last) paragraph of Article 280.08 of the Standard Specifications.

Revise the second sentence of the first paragraph of Article 1081.15(e) of the Standard Specifications to read:

“The upstream facing of the aggregate ditch check shall be constructed of gradation CA 3. The remainder of the ditch check shall be constructed of gradation RR 3.”

TRAFFIC BARRIER TERMINAL, TYPE 6 (BDE)

Effective: January 1, 2010

Delete the fourth paragraph of Article 631.07 of the Standard Specifications.

TRUCK MOUNTED/TRAILER MOUNTED ATTENUATORS (BDE)

Effective: January 1, 2010

Revise Article 701.03(k) of the Standard Specifications to read:

“(k) Truck Mounted/Trailer Mounted Attenuators 1106.02”

Revise Article 701.15(h) of the Standard Specifications to read:

“(h) Truck Mounted/Trailer Mounted Attenuators (TMA). TMA units shall have a roll ahead distance in the event of an impact. The TMA shall be between 100 and 200 ft (30 and 60 m) behind the vehicle ahead or the workers. This distance may be extended by the Engineer.

TMA host vehicles shall have the parking brake engaged when stationary.

The driver and passengers of the TMA host vehicle should exit the vehicle if the TMA is to remain stationary for 15 minutes or more in duration.”

Revise Article 1106.02(g) of the Standard Specifications to read:

“(g) Truck Mounted/Trailer Mounted Attenuators. The attenuator shall be a NCHRP 350 approved unit for Test Level 3. Test Level 2 may be used as directed by the Engineer for normal posted speeds less than or equal to 45 mph.”

COMPLETION DATE PLUS GUARANTEED WORKING DAYS

The Contractor shall complete all contract items and safely open all roadways to traffic by July 1, 2012, except as specified herein.

The Contractor will be allowed to complete highway lighting, seeding, all clean-up work, and punch list items within sixty(60) guaranteed working days after the completion date for opening the roadway to traffic. Under extenuating circumstances the Engineer may direct that certain items of work, not affecting the safe opening of the roadway to traffic, may be completed within the guaranteed working days allowed for highway lighting, seeding, clean-up work, and punch list items. Temporary lane closures for this work may be allowed at the discretion of the Engineer.

Article 108.09 of the Standard Specifications, or the Special Provision for Failure to Complete the Work on Time, if included in this Contract, shall apply to both the completion date and the number of working days.

BITUMINOUS MATERIALS COST ADJUSTMENTS (BDE) (RETURN FORM WITH BID)

Effective: November 2, 2006

Revised: April 1, 2009

Description. Bituminous material cost adjustments will be made to provide additional compensation to the Contractor, or credit to the Department, for fluctuations in the cost of bituminous materials when optioned by the Contractor. The adjustments shall apply to permanent and temporary hot-mix asphalt (HMA) mixtures, bituminous surface treatments (cover and seal coats), and pavement preservation type surface treatments. The adjustments shall not apply to bituminous prime coats, tack coats, crack filling/sealing, or joint filling/sealing.

The bidder shall indicate on the attached form whether or not this special provision will be part of the contract and submit the completed form with his/her bid. Failure to submit the form, or failure to fill out the form completely, shall make this contract exempt of bituminous materials cost adjustments.

Method of Adjustment. Bituminous materials cost adjustments will be computed as follows.

$$CA = (BPI_P - BPI_L) \times (\%AC_V / 100) \times Q$$

Where: CA = Cost Adjustment, \$.

BPI_P = Bituminous Price Index, as published by the Department for the month the work is performed, \$/ton (\$/metric ton).

BPI_L = Bituminous Price Index, as published by the Department for the month prior to the letting, \$/ton (\$/metric ton).

%AC_V = Percent of virgin Asphalt Cement in the Quantity being adjusted. For HMA mixtures, the % AC_V will be determined from the adjusted job mix formula. For bituminous materials applied, a performance graded or cutback asphalt will be considered to be 100% AC_V and undiluted emulsified asphalt will be considered to be 65% AC_V.

Q = Authorized construction Quantity, tons (metric tons) (see below).

For HMA mixtures measured in square yards: $Q, \text{ tons} = A \times D \times (G_{mb} \times 46.8) / 2000$. For HMA mixtures measured in square meters: $Q, \text{ metric tons} = A \times D \times (G_{mb} \times 24.99) / 1000$. When computing adjustments for full-depth HMA pavement, separate calculations will be made for the binder and surface courses to account for their different G_{mb} and % AC_v.

For bituminous materials measured in gallons: $Q, \text{ tons} = V \times 8.33 \text{ lb/gal} \times SG / 2000$
For bituminous materials measured in liters: $Q, \text{ metric tons} = V \times 1.0 \text{ kg/L} \times SG / 1000$

Where: A = Area of the HMA mixture, sq yd (sq m).
D = Depth of the HMA mixture, in. (mm).
 G_{mb} = Average bulk specific gravity of the mixture, from the approved mix design.
V = Volume of the bituminous material, gal (L).
SG = Specific Gravity of bituminous material as shown on the bill of lading.

Basis of Payment. Bituminous materials cost adjustments may be positive or negative but will only be made when there is a difference between the BPI_L and BPI_P in excess of five percent, as calculated by:

$$\text{Percent Difference} = \{(BPI_L - BPI_P) \div BPI_L\} \times 100$$

Bituminous materials cost adjustments will be calculated for each calendar month in which applicable bituminous material is placed; and will be paid or deducted when all other contract requirements for the work placed during the month are satisfied. The adjustments shall not apply during contract time subject to liquidated damages for completion of the entire contract.

RETURN WITH BID

ILLINOIS DEPARTMENT OF TRANSPORTATION

OPTION FOR BITUMINOUS MATERIALS COST ADJUSTMENTS

The bidder shall submit this completed form with his/her bid. Failure to submit the form, or failure to fill out the form completely, shall make this contract exempt of bituminous materials cost adjustments. After award, this form, when submitted, shall become part of the contract.

Contract No.: _____

Company Name: _____

Contractor's Option:

Is your company opting to include this special provision as part of the contract?

Yes No

Signature: _____ **Date:** _____

FUEL COST ADJUSTMENT (BDE) (RETURN FORM WITH BID)

Effective: April 1, 2009

Revised: July 1, 2009

Description. Fuel cost adjustments will be made to provide additional compensation to the Contractor, or a credit to the Department, for fluctuations in fuel prices when optioned by the Contractor. The bidder shall indicate on the attached form whether or not this special provision will be part of the contract and submit the completed form with his/her bid. Failure to submit the form or failure to indicate contract number, company name and sign and date the form shall make this contract exempt of fuel cost adjustments for all categories of work. Failure to indicate "Yes" for any category of work will make that category of work exempt from fuel cost adjustment.

General. The fuel cost adjustment shall apply to contract pay items as grouped by category. The adjustment shall only apply to those categories of work checked "Yes", and only when the cumulative plan quantities for a category exceed the required threshold. Adjustments to work items in a category, either up or down, and work added by adjusted unit price will be subject to fuel cost adjustment only when the category representing the added work was subject to the fuel cost adjustment. Added work paid for by time and materials will not be subject to fuel cost adjustment. Category descriptions and thresholds for application and the fuel usage factors which are applicable to each are as follows:

(a) Categories of Work.

- (1) Category A: Earthwork. Contract pay items performed under Sections 202, 204, and 206 including any modified standard or nonstandard items where the character of the work to be performed is considered earthwork. The cumulative total of all applicable item plan quantities shall exceed 25,000 cu yd (20,000 cu m). Included in the fuel usage factor is a weighted average 0.10 gal/cu yd (0.50 liters/cu m) factor for trucking.
- (2) Category B: Subbases and Aggregate Base Courses. Contract pay items constructed under Sections 311, 312 and 351 including any modified standard or nonstandard items where the character of the work to be performed is considered construction of a subbase or aggregate, stabilized or modified base course. The cumulative total of all applicable item plan quantities shall exceed 5000 tons (4500 metric tons). Included in the fuel usage factor is a 0.60 gal/ton (2.50 liters/metric ton) factor for trucking.
- (3) Category C: Hot-Mix Asphalt (HMA) Bases, Pavements and Shoulders. Contract pay items constructed under Sections 355, 406, 407 and 482 including any modified standard or nonstandard items where the character of the work to be performed is considered HMA bases, pavements and shoulders. The cumulative total of all applicable item plan quantities shall exceed 5000 tons (4500 metric tons). Included in the fuel usage factor is 0.60 gal/ton (2.50 liters/metric ton) factor for trucking.

- (4) Category D: Portland Cement Concrete (PCC) Bases, Pavements and Shoulders. Contract pay items constructed under Sections 353, 420, 421 and 483 including any modified standard or nonstandard items where the character of the work to be performed is considered PCC base, pavement or shoulder. The cumulative total of all applicable item plan quantities shall exceed 7500 sq yd (6000 sq m). Included in the fuel usage factor is 1.20 gal/cu yd (5.94 liters/cu m) factor for trucking.
- (5) Category E: Structures. Structure items having a cumulative bid price that exceeds \$250,000 for pay items constructed under Sections 502, 503, 504, 505, 512, 516 and 540 including any modified standard or nonstandard items where the character of the work to be performed is considered structure work when similar to that performed under these sections and not included in categories A through D.

(b) Fuel Usage Factors.

English Units

Category	Factor	Units
A - Earthwork	0.34	gal / cu yd
B – Subbase and Aggregate Base courses	0.62	gal / ton
C – HMA Bases, Pavements and Shoulders	1.05	gal / ton
D – PCC Bases, Pavements and Shoulders	2.53	gal / cu yd
E – Structures	8.00	gal / \$1000

Metric Units

Category	Factor	Units
A - Earthwork	1.68	liters / cu m
B – Subbase and Aggregate Base courses	2.58	liters / metric ton
C – HMA Bases, Pavements and Shoulders	4.37	liters / metric ton
D – PCC Bases, Pavements and Shoulders	12.52	liters / cu m
E – Structures	30.28	liters / \$1000

(c) Quantity Conversion Factors.

Category	Conversion	Factor
B	sq yd to ton	0.057 ton / sq yd / in depth
	sq m to metric ton	0.00243 metric ton / sq m / mm depth
C	sq yd to ton	0.056 ton / sq yd / in depth
	sq m to metric ton	0.00239 m ton / sq m / mm depth
D	sq yd to cu yd	0.028 cu yd / sq yd / in depth
	sq m to cu m	0.001 cu m / sq m / mm depth

Method of Adjustment. Fuel cost adjustments will be computed as follows.

$$CA = (FPI_P - FPI_L) \times FUF \times Q$$

Where: CA = Cost Adjustment, \$
FPI_P = Fuel Price Index, as published by the Department for the month the work is performed, \$/gal (\$/liter)
FPI_L = Fuel Price Index, as published by the Department for the month prior to the letting, \$/gal (\$/liter)
FUF = Fuel Usage Factor in the pay item(s) being adjusted
Q = Authorized construction Quantity, tons (metric tons) or cu yd (cu m)

The entire FUF indicated in paragraph (b) will be used regardless of use of trucking to perform the work.

Progress Payments. Fuel cost adjustments will be calculated for each calendar month in which applicable work is performed; and will be paid or deducted when all other contract requirements for the items of work are satisfied. The adjustments shall not apply during contract time subject to liquidated damages for completion of the entire contract.

Final Quantities. Upon completion of the work and determination of final pay quantities, an adjustment will be prepared to reconcile any differences between estimated quantities previously paid and the final quantities. The value for the balancing adjustment will be based on a weighted average of FPI_P and Q only for those months requiring the cost adjustment. The cost adjustment will be applicable to the final measured quantities of all applicable pay items.

Basis of Payment. Fuel cost adjustments may be positive or negative but will only be made when there is a difference between the FPI_L and FPI_P in excess of five percent, as calculated by:

$$\text{Percent Difference} = \{(FPI_L - FPI_P) \div FPI_L\} \times 100$$

Return With Bid

**ILLINOIS DEPARTMENT
OF TRANSPORTATION**

**OPTION FOR
FUEL COST ADJUSTMENT**

The bidder shall submit this completed form with his/her bid. Failure to submit the form or properly complete contract number, company name, and sign and date the form shall make this contract exempt of fuel cost adjustments in all categories. Failure to indicate "Yes" for any category of work at the time of bid will make that category of work exempt from fuel cost adjustment. After award, this form, when submitted shall become part of the contract.

Contract No.: _____

Company Name: _____

Contractor's Option:

Is your company opting to include this special provision as part of the contract plans for the following categories of work?

- | | | |
|--|-----|--------------------------|
| Category A Earthwork. | Yes | <input type="checkbox"/> |
| Category B Subbases and Aggregate Base Courses | Yes | <input type="checkbox"/> |
| Category C HMA Bases, Pavements and Shoulders | Yes | <input type="checkbox"/> |
| Category D PCC Bases, Pavements and Shoulders | Yes | <input type="checkbox"/> |
| Category E Structures | Yes | <input type="checkbox"/> |

Signature: _____ **Date:** _____

STEEL COST ADJUSTMENT (BDE) (RETURN FORM WITH BID)

Effective: April 2, 2004

Revised: April 1, 2009

Description. Steel cost adjustments will be made to provide additional compensation to the Contractor, or a credit to the Department, for fluctuations in steel prices when optioned by the Contractor. The bidder shall indicate on the attached form whether or not this special provision will be part of the contract and submit the completed form with his/her bid. Failure to submit the form or failure to indicate contract number, company name, and sign and date the form shall make this contract exempt of steel cost adjustments for all items of steel. Failure to indicate "Yes" for any item of work will make that item of steel exempt from steel cost adjustment.

Types of Steel Products. An adjustment will be made for fluctuations in the cost of steel used in the manufacture of the following items:

- Metal Piling (excluding temporary sheet piling)
- Structural Steel
- Reinforcing Steel

Other steel materials such as dowel bars, tie bars, mesh reinforcement, guardrail, steel traffic signal and light poles, towers and mast arms, metal railings (excluding wire fence), and frames and grates will be subject to a steel cost adjustment when the pay items they are used in has a contract value of \$10,000 or greater.

Documentation. Sufficient documentation shall be furnished to the Engineer to verify the following:

- (a) The dates and quantity of steel, in lb (kg), shipped from the mill to the fabricator.
- (b) The quantity of steel, in lb (kg), incorporated into the various items of work covered by this special provision. The Department reserves the right to verify submitted quantities.

Method of Adjustment. Steel cost adjustments will be computed as follows:

$$SCA = Q \times D$$

Where: SCA = steel cost adjustment, in dollars
Q = quantity of steel incorporated into the work, in lb (kg)
D = price factor, in dollars per lb (kg)

$$D = MPI_M - MPI_L$$

Where: MPI_M = The Materials Cost Index for steel as published by the Engineering News-Record for the month the steel is shipped from the mill. The indices will be converted from dollars per 100 lb to dollars per lb (kg).

MPI_L = The Materials Cost Index for steel as published by the Engineering News-Record for the month prior to the letting. The indices will be converted from dollars per 100 lb to dollars per lb (kg).

The unit weights (masses) of steel that will be used to calculate the steel cost adjustment for the various items are shown in the attached table.

No steel cost adjustment will be made for any products manufactured from steel having a mill shipping date prior to the letting date.

If the Contractor fails to provide the required documentation, the method of adjustment will be calculated as described above; however, the MPI_M will be based on the date the steel arrives at the job site. In this case, an adjustment will only be made when there is a decrease in steel costs.

Basis of Payment. Steel cost adjustments may be positive or negative but will only be made when there is a difference between the MPI_L and MPI_M in excess of five percent, as calculated by:

$$\text{Percent Difference} = \{(MPI_L - MPI_M) \div MPI_L\} \times 100$$

Steel cost adjustments will be calculated by the Engineer and will be paid or deducted when all other contract requirements for the items of work are satisfied. Adjustments will only be made for fluctuations in the cost of the steel as described herein. No adjustment will be made for changes in the cost of manufacturing, fabrication, shipping, storage, etc.

The adjustments shall not apply during contract time subject to liquidated damages for completion of the entire contract.

Attachment

Item	Unit Mass (Weight)
Metal Piling (excluding temporary sheet piling)	
Furnishing Metal Pile Shells 12 in. (305 mm), 0.179 in. (3.80 mm) wall thickness)	23 lb/ft (34 kg/m)
Furnishing Metal Pile Shells 12 in. (305 mm), 0.250 in. (6.35 mm) wall thickness)	32 lb/ft (48 kg/m)
Furnishing Metal Pile Shells 14 in. (356 mm), 0.250 in. (6.35 mm) wall thickness)	37 lb/ft (55 kg/m)
Other piling	See plans
Structural Steel	See plans for weights (masses)
Reinforcing Steel	See plans for weights (masses)
Dowel Bars and Tie Bars	6 lb (3 kg) each
Mesh Reinforcement	63 lb/100 sq ft (310 kg/sq m)
Guardrail	
Steel Plate Beam Guardrail, Type A w/steel posts	20 lb/ft (30 kg/m)
Steel Plate Beam Guardrail, Type B w/steel posts	30 lb/ft (45 kg/m)
Steel Plate Beam Guardrail, Types A and B w/wood posts	8 lb/ft (12 kg/m)
Steel Plate Beam Guardrail, Type 2	305 lb (140 kg) each
Steel Plate Beam Guardrail, Type 6	1260 lb (570 kg) each
Traffic Barrier Terminal, Type 1 Special (Tangent)	730 lb (330 kg) each
Traffic Barrier Terminal, Type 1 Special (Flared)	410 lb (185 kg) each
Steel Traffic Signal and Light Poles, Towers and Mast Arms	
Traffic Signal Post	11 lb/ft (16 kg/m)
Light Pole, Tenon Mount and Twin Mount, 30 - 40 ft (9 - 12 m)	14 lb/ft (21 kg/m)
Light Pole, Tenon Mount and Twin Mount, 45 - 55 ft (13.5 - 16.5 m)	21 lb/ft (31 kg/m)
Light Pole w/Mast Arm, 30 - 50 ft (9 - 15.2 m)	13 lb/ft (19 kg/m)
Light Pole w/Mast Arm, 55 - 60 ft (16.5 - 18 m)	19 lb/ft (28 kg/m)
Light Tower w/Luminaire Mount, 80 - 110 ft (24 - 33.5 m)	31 lb/ft (46 kg/m)
Light Tower w/Luminaire Mount, 120 - 140 ft (36.5 - 42.5 m)	65 lb/ft (97 kg/m)
Light Tower w/Luminaire Mount, 150 - 160 ft (45.5 - 48.5 m)	80 lb/ft (119 kg/m)
Metal Railings (excluding wire fence)	
Steel Railing, Type SM	64 lb/ft (95 kg/m)
Steel Railing, Type S-1	39 lb/ft (58 kg/m)
Steel Railing, Type T-1	53 lb/ft (79 kg/m)
Steel Bridge Rail	52 lb/ft (77 kg/m)
Frames and Grates	
Frame	250 lb (115 kg)
Lids and Grates	150 lb (70 kg)

RETURN WITH BID

ILLINOIS DEPARTMENT OF TRANSPORTATION

OPTION FOR STEEL COST ADJUSTMENT

The bidder shall submit this completed form with his/her bid. Failure to submit the form or properly complete contract number, company name, and sign and date the form shall make this contract exempt of steel cost adjustments for all items of steel. Failure to indicate "Yes" for any item of work will make that item of steel exempt from steel cost adjustment. After award, this form, when submitted shall become part of the contract.

Contract No.: _____

Company Name: _____

Contractor's Option:

Is your company opting to include this special provision as part of the contract plans for the following items of work?

- | | | |
|--|-----|--------------------------|
| Metal Piling | Yes | <input type="checkbox"/> |
| Structural Steel | Yes | <input type="checkbox"/> |
| Reinforcing Steel | Yes | <input type="checkbox"/> |
| Dowel Bars, Tie Bars and Mesh Reinforcement | Yes | <input type="checkbox"/> |
| Guardrail | Yes | <input type="checkbox"/> |
| Steel Traffic Signal and Light Poles, Towers and Mast Arms | Yes | <input type="checkbox"/> |
| Metal Railings (excluding wire fence) | Yes | <input type="checkbox"/> |
| Frames and Grates | Yes | <input type="checkbox"/> |

Signature: _____ **Date:** _____

Illinois Department of Transportation
PROJECT LABOR AGREEMENT

This Project Labor Agreement ("PLA") is entered into this _____ day of _____, by and between the Illinois Department of Transportation ("IDOT" or "Department") in its proprietary capacity, and each relevant Illinois AFL-CIO Building Trades Council made signatory hereto by the Illinois AFL-CIO Statewide Project Labor Agreement Committee on behalf of itself and each of its affiliated members (individually and collectively, the "Union"). This PLA shall apply to Construction Work (as defined herein) to be performed by IDOT's Prime Contractor and each of its relevant subcontractors of whatever tier ("Subcontractor" or "Subcontractors") on Contract 74296 (hereinafter, the "Project").

ARTICLE 1 - INTENT AND PURPOSES

- 1.1. This PLA is entered into in furtherance of Illinois Executive Order No. 2003-13. It is mutually understood and agreed that the terms and conditions of this PLA are intended to promote the public interest in obtaining timely and economical completion of the Project by encouraging productive and efficient construction operations; by establishing a spirit of harmony and cooperation among the parties; and by providing for peaceful and prompt settlement of any and all labor grievances or jurisdictional disputes of any kind without strikes, lockouts, slowdowns, delays or other disruptions to the prosecution of the work.
- 1.2. As a condition of the award of the contract for performance of work on the Project, IDOT's Prime Contractor and each of its Subcontractors shall be required to sign a "Contractor Letter of Assent", in the form attached hereto as Exhibit A, prior to commencing Construction Work on the Project. Each Union affiliate and separate local representing workers engaged in Construction Work on the Project in accordance with this PLA are bound to this agreement by the Illinois AFL-CIO Statewide Project Labor Agreement Committee which is the central committee established with full authority to negotiate and sign PLAs with the State on behalf of all respective crafts. Upon their signing the Letter of Assent, the Prime Contractor, each Subcontractor, and the individual Unions shall thereafter be deemed a party to this PLA. No party signatory to this PLA shall, contract or subcontract, nor permit any other person, firm, company or entity to contract or subcontract for the performance of Construction Work for the Project to any person, firm, company or entity that does not agree in writing to become bound by the terms of this PLA prior to commencing such work.
- 1.3. It is understood that the Prime Contractor(s) and each Subcontractor will be considered and accepted by the Unions as separate employers for the purposes of collective bargaining, and it is further agreed that the employees working under this PLA shall constitute a bargaining unit separate and distinct from all others. The Parties hereto also agree that this PLA shall be applicable solely with respect to this Project, and shall have no bearing on the interpretation of any other collective bargaining agreement or as to the recognition of any bargaining unit other than for the specific purposes of this Project.

- 1.4. In the event of a variance or conflict, whether explicit or implicit, between the terms and conditions of this PLA and the provisions of any other applicable national, area, or local collective bargaining agreement, the terms and conditions of this PLA shall supersede and control. For any work performed under the NTL Articles of Agreement, the National Stack/Chimney Agreement, the National Cooling Tower Agreement, the National Agreement of the International Union of Elevator Constructors, and for any instrument calibration work and loop checking performed under the UA/IBEW Joint National Agreement for Instrument and Control Systems Technicians, the preceding sentence shall apply only with respect to Articles I, II, V, VI, and VII.
- 1.5. Subject to the provisions of paragraph 1.4 of this Article, it is the parties' intent to respect the provisions of any other collective bargaining agreements that may now or hereafter pertain, whether between the Prime Contractor and one or more of the Unions or between a Subcontractor and one or more of the Unions. Accordingly, except and to the extent of any contrary provision set forth in this PLA, the Prime Contractor and each of its Subcontractors agrees to be bound and abide by the terms of the following in order of precedence: (a) the applicable collective bargaining agreement between the Prime Contractor and one or more of the Unions made signatory hereto; (b) the applicable collective bargaining agreement between a Subcontractor and one or more of the Unions made signatory hereto; or (c) the current applicable area collective bargaining agreement for the relevant Union that is the agreement certified by the Illinois Department of Labor for purposes of establishing the Prevailing Wage applicable to the Project. The Union will provide copies of the applicable collective bargaining agreements pursuant to part (c) of the preceding sentence to the Prime Contractor. Assignments by the Contractors amongst the trades shall be consistent with area practices; in the event of unresolved disagreements as to the propriety of such assignments, the provisions of Article VI shall apply.
- 1.6. Subject to the limitations of paragraphs 1.4 and 1.5 of this Article, the terms of each applicable collective bargaining agreement as determined in accordance with paragraph 1.5 are incorporated herein by reference, and the terms of this PLA shall be deemed incorporated into such other applicable collective bargaining agreements only for purposes of their application to the Project.
- 1.7. To the extent necessary to comply with the requirements of any fringe benefit fund to which the Prime Contractor or Subcontractor is required to contribute under the terms of an applicable collective bargaining agreement pursuant to the preceding paragraph, the Prime Contractor or Subcontractor shall execute all "Participation Agreements" as may be reasonably required by the Union to accomplish such purpose; provided, however, that such Participation Agreements shall, when applicable to the Prime Contractor or Subcontractor solely as a result of this PLA, be amended as reasonably necessary to reflect such fact. Upon written notice from any applicable fringe benefit fund, IDOT will withhold from the Prime Contractor payment of any delinquencies arising from this Project.

- 1.8. In the event that the applicable collective bargaining agreement between a Prime Contractor and the Union or between the Subcontractor and the Union expires prior to the completion of this Project, the expired applicable contract's terms will be maintained until a new applicable collective bargaining agreement is ratified. The wages and fringe benefits included in any new applicable collective bargaining agreement will apply on and after the effective date of the newly negotiated collective bargaining agreement, except to the extent wage and fringe benefit retroactivity is specifically agreed upon by the relevant bargaining parties.

ARTICLE II – APPLICABILITY, RECOGNITION, AND COMMITMENTS

- 2.1 The term Construction Work as used herein shall include all “construction, prosecution, completion, or repair” work performed by a “laborer or mechanic” at the “site of the work” for the purpose of “building” the specific structures and improvements that constitute the Project. Terms appearing within quotation marks in the preceding sentence shall have the meaning ascribed to them pursuant to 29 CFR Part 5.
- 2.2 By executing the Letters of Assent, Prime Contractor and each of its Subcontractors recognizes the Unions signatory to this PLA as the sole and exclusive bargaining representatives for their craft employees employed on the jobsite for this Project. Unions who are signatory to this PLA will have recognition on the Project for their craft.
- 2.3 The Prime Contractor and each of its Subcontractors retains and shall be permitted to exercise full and exclusive authority and responsibility for the management of its operations, except as expressly limited by the terms of this PLA or by the terms and conditions of the applicable collective bargaining agreement.
- 2.4 Except to the extent contrary to an express provision of the relevant collective bargaining agreement, equipment or materials used in the Project may be pre-assembled or pre-fabricated, and there shall be no refusal by the Union to handle, transport, install, or connect such equipment or materials. Equipment or materials delivered to the job-site will be unloaded and handled promptly without regard to potential jurisdictional disputes; any such disputes shall be handled in accordance with the provisions of this PLA.
- 2.5 Unions commit to furnishing qualified and skilled craft persons as required by the Prime Contractor and its Subcontractors in fulfillment of their obligations to complete the Project. In order to promote the long-term development of a skilled and knowledgeable work force, the parties are encouraged to utilize apprentices to the maximum extent permitted by the applicable collective bargaining agreement.
- 2.6 The parties are mutually committed to promoting a safe working environment for all personnel at the job site. It shall be the responsibility of each employer to which this PLA applies to provide and maintain safe working conditions for its employees, and to comply with all applicable federal, state, and local health and safety laws and regulations.

- 2.7 The use or furnishing of alcohol or drugs and the conduct of any other illegal activity at the job-site is strictly prohibited. The parties shall take every practical measure consistent with the terms of applicable collective bargaining agreements to ensure that the job-site is free of alcohol and drugs.
- 2.8 All parties to this PLA agree that they shall not discriminate against any employee based on race, creed, color, national origin, union activity, age, or gender as required by all applicable federal, state, and local laws.
- 2.9 The Parties hereto agree that engineering consultants and materials testing employees, to the extent subject to the terms of this PLA, shall be fully expected to objectively and responsibly perform their duties and obligations owed to the Department without regard to the potential union affiliation of such employees or of other employees on the Project.

ARTICLE III - ADMINISTRATION OF AGREEMENT

- 3.1 In order to assure that all parties have a clear understanding of the PLA and to promote harmony, a post-award pre-job conference will be held among the Prime Contractor, all Subcontractors and Union representatives prior to the start of any Construction Work on the Project. No later than the conclusion of such pre-job conference, the parties shall, among other matters, provide to one another contact information for their respective representatives (including name, address, phone number, facsimile number, e-mail). Nothing herein shall be construed to limit the right of the Department to discuss or explain the purpose and intent of this PLA with prospective bidders or other interested parties prior to or following its award of the job.
- 3.2 Representatives of the Prime Contractor and the Unions shall meet as often as reasonably necessary following award until completion of the Project to assure the effective implementation of this PLA.
- 3.3 Not less than once per month, Prime Contractor and all Subcontractors shall make available in writing to the Unions a Project status report that shall include, though not necessarily be limited to, planned activities for the next 30 day period and estimated numbers of employees by craft required for the next 30 day period. The purpose of this Project status report is to promote effective workforce planning and to facilitate resolution of any potential jurisdictional or other problems.
- 3.4 Not later than the earlier of (a) five business days following the pre-job conference, or (b) commencement of Construction Work, the Unions and Prime Contractor (on behalf of itself and all its subcontractors of whatever tier) shall confer and jointly designate a slate of three (3) permanent arbitrators (each a "Permanent Arbitrator") for the purpose of hearing disputes pursuant to Articles V and VII of this PLA. The slate of Permanent Arbitrators shall be selected from among the following individuals: Thomas F. Gibbons, Thomas G. Pagan, Robert Perkovich, Byron Yaffee, and Glenn A. Zipp. In the event that the Unions and Prime Contractor are not able to agree on a full slate of three Permanent Arbitrators, the Department, after consultation with the Unions and Prime Contractor, shall designate such additional Permanent Arbitrators as may be necessary to establish the full slate.

A single Permanent Arbitrator shall be selected from the slate of three on a rotating basis to adjudicate each arbitrable matter as it arises. In the event a Permanent Arbitrator is not available to adjudicate a particular matter in the order of rotation, the arbitration assignment shall pass to the next available Permanent Arbitrator.

ARTICLE IV - HOURS OF WORK AND GENERAL CONDITIONS

- 4.1 The standard work day for Construction Work on the Project shall be an established consecutive eight (8) hour period between the hours of 7:00 a.m. and 5:00 p.m. with one-half hour designated as unpaid period for lunch. The standard work week shall be five (5) consecutive days of work commencing on Monday. Starting time shall be established at the pre-job conference, and shall be applicable to all craft employees on the Project unless otherwise expressly agreed in writing. In the event Project site or other job conditions dictate a change in the established starting time and/or a staggered lunch period for portions of the Project or for specific crafts, the Prime Contractor, relevant Subcontractors and business managers of the specific crafts involved shall confer and mutually agree to such changes as appropriate. If proposed work schedule changes cannot be mutually agreed upon between the parties, the hours fixed at the time of the pre-job meeting shall prevail.
- 4.2 Shift work may be established and directed by the Prime Contractor or relevant Subcontractor as reasonably necessary or appropriate to fulfill the terms of its contract with the Department. If used, shift hours, rates and conditions shall be as provided in the applicable collective bargaining agreement.
- 4.3 The parties agree that chronic and/or unexcused absenteeism is undesirable and must be controlled in accordance with procedures established by the applicable collective bargaining agreement. Any employee disciplined for absenteeism in accordance with such procedures shall be suspended from all work on the Project for not less than the maximum period permitted under the applicable collective bargaining agreement.
- 4.4 Except as may be otherwise expressly provided by the applicable collective bargaining agreement, employment begins and ends at the Project site; employees shall be at their place of work at the starting time; and employees shall remain at their place of work until quitting time.
- 4.5 Except as may be otherwise expressly provided by the applicable collective bargaining agreement, there shall be no limit on production by workmen, no restrictions on the full use of tools or equipment, and no restrictions on efficient use of manpower or techniques of construction other than as may be required by safety regulations.

- 4.6 The parties recognize that specialized or unusual equipment may be installed on the Project. In such cases, the Union recognizes the right of the Prime Contractor or Subcontractor to involve the equipment supplier or vendor's personnel in supervising the setting up of the equipment, making modifications and final alignment, and performing similar activities that may be reasonably necessary prior to and during the start-up procedure in order to protect factory warranties. The Prime Contractor or Subcontractor shall notify the Union representatives in advance of any work at the job-site by such vendor personnel in order to promote a harmonious relationship between the equipment vendor's personnel and other Project employees.
- 4.7 For the purpose of promoting full and effective implementation of this PLA, authorized Union representatives shall have access to the Project job-site during scheduled work hours. Such access shall be conditioned upon adherence to all reasonable visitor and security rules of general applicability that may be established for the Project site at the pre-job conference or from time to time thereafter.

ARTICLE V - GRIEVANCE AND ARBITRATION PROCEDURES

- 5.1 Except as provided in Articles VI or VII, it is specifically agreed among the parties that any grievance or dispute arising out of the interpretation or application of this PLA shall be settled by means of the expedited arbitration process set forth in Paragraph 5.2 below. No such grievance or dispute shall be recognized unless called to the attention of the Prime Contractor and relevant Subcontractor by the Union or to the Union by the Prime Contractor or relevant Subcontractor within five (5) working days after the alleged violation was committed or discovered by the grieving party.
- 5.2 Grievances shall be settled according to the following procedure:
- 5.2.A. Step 1. The dispute shall be referred to the Steward of the craft union involved and a representative of the Prime Contractor and relevant Subcontractor at the job-site.
- 5.2.B. Step 2. In the event that the Steward and the contractors' representatives at the job-site cannot reach agreement within two (2) working days after a meeting is arranged and held, the matter shall be referred to the Union Business Manager and to executive representatives of the Prime Contractor and relevant Subcontractor.
- 5.2.C. Step 3. In the event the dispute is not resolved within five (5) working days after completion of Step 2, the relevant parties shall request a Permanent Arbitrator as determined in accordance with paragraph 3.4 of this PLA, who shall, within ten (10) working days, hear the grievance and make a written decision. Such decisions shall be final and binding on all parties. The parties shall each pay the expense of their own representative. The expense of the Permanent Arbitrator shall be divided equally between (1) the Prime Contractor and/or relevant Subcontractor, and (2) the involved Union.

- 5.3 Any failure of a party to comply fully with such final and binding decision of the Permanent Arbitrator may result in removal of the non-complying party from the site, in a holdback from the Prime Contractor or Subcontractor of any amounts awarded, or in such other relief as the Department may reasonably determine is necessary to promote final resolution of the dispute.
- 5.4 In the event any dispute or grievance should arise, the parties expressly agree that it shall be resolved without occurrence of any strike, work stoppage, slow-down or other prohibited activities as provided in Article VII of this PLA. Individuals or parties violating this section shall be subject to immediate discharge or other discipline.

ARTICLE VI - JURISDICTIONAL DISPUTES

- 6.1 As used in this Agreement, the term "jurisdictional dispute" shall be defined as any dispute, difference or disagreement involving the assignment of particular work to one class or craft of employees rather than to a different class or craft of employees, regardless of that Contractor's contractual relationship to any other employer, contractor, or organization on the site.
- 6.2 It is agreed by and between the parties to this Agreement that any and all jurisdictional disputes shall be resolved in the following manner; each of the steps hereinafter listed shall be initiated by the parties in sequence as set forth:
 - (a) Negotiation by and between the Local Business Representative of the disputing Union and Employer shall take place within two (2) business days. Business days are defined as Monday through Friday excluding contract holidays. Such negotiations shall be pursued until it is apparent that the dispute cannot be resolved at the local level.
 - (b) The International Representatives of the disputing Union shall meet or confer and attempt to resolve said dispute. This meeting shall take place within two (2) business days. Business days are defined as Monday through Friday excluding contract holidays.
 - (c) The parties to the Jurisdictional Dispute shall submit the dispute directly to an Arbitrator after complying with paragraph (2b) above. The parties shall meet with the Arbitrator within three (3) business days. Business days are defined as Monday through Friday excluding contract holidays. An Arbitrator will be selected based on availability from the slate of permanent Arbitrators. The Arbitrator's bench decision will be given the day of the hearing and will be final and legally binding on this project only. The Arbitrator's bench decision will be implemented without delay. The cost of Arbitration will be shared equally by the disputing parties. Any party to the dispute can require that a "long form" written decision be provided from the Arbitrator, however the cost of the "long form" written decision will be the responsibility of the party making the request.

Notes:

- A jurisdictional dispute may be submitted based upon a pre-job assignment.
 - If any party to the jurisdictional disputes does not fully comply with the steps and time limits with each step, then the party in non-compliance will lose by “automatic default”.
 - Time limits at any step can be extended if all parties to the jurisdictional dispute mutually agree in writing.
 - All parties to a jurisdictional dispute can mutually agree to waive the time limits in steps (a) and (b) and proceed directly to an expedited arbitration hearing.
- (d) In rendering his decision, the Arbitrator shall determine:
- (1) First whether a previous agreement of record or applicable agreement, including a disclaimer agreement, between the National or International Unions to the dispute governs;
 - (2) Only if the Arbitrator finds that the dispute is not covered by an appropriate or applicable agreement of record or agreement between the crafts to the dispute, he shall then consider whether there is a previous decision of record governing the case;
 - (3) If the Arbitrator finds that a previous decision of record governs the case, the Arbitrator shall apply the decision of record in rendering his decision except under the following circumstances. After notice to the other parties to the dispute prior to the hearing that it intends to challenge the decision of record, if a trade challenging the decision of record is able to demonstrate that the recognized and established prevailing practice in the locality of the work has been contrary to the applicable decision of record, and that historically in that locality the work in dispute has not been performed by the other craft or crafts, the Arbitrator may rely on such prevailing practice rather than the decision of record. If the craft relying on the decision of record demonstrates that it has performed the work in dispute in the locality of the job, then the Arbitrator shall apply the decision of record in rendering his decision. If the Arbitrator finds that a craft has improperly obtained the prevailing practice in the locality through raiding, the undercutting of wagers or by the use of vertical agreements, the Arbitrator shall rely on the decision of record rather than the prevailing practice in the locality.
 - (4) If no decision of record is applicable, the Arbitrator shall then consider the established trade practice in the industry and prevailing practice in the locality; and

- (5) Only if none of the above criteria is found to exist, the Arbitrator shall then consider that because efficiency, cost or continuity and good management are essential to the well being of the industry, the interest of the consumer or the past practice of the employer shall not be ignored.

The Arbitrator shall set forth the basis for his decision and shall explain his findings regarding the applicability of the above criteria. If lower-ranked criteria are relied upon, the Arbitrator shall explain why the higher-ranked criteria were not deemed applicable. The Arbitrator's decision shall only apply to the job in dispute.

- (6) Agreements of record are applicable only to the party's signatory to such agreements. Decisions of record are applicable to all trades.
- (7) The Arbitrator is not authorized to award back pay or any other damages for a mis-assignment of work. Nor may any party bring an independent action for back pay or any other damages, based upon a decision of an Arbitrator.

6.3 The signatory parties to this Agreement agree that jurisdictional disputes cannot and shall not interfere with the efficient and continuous operations required for the successful application of this Agreement. In the event a dispute arises, the Contractor's assignment shall be followed until the dispute is resolved.

6.4 Equipment or material delivered to the job site will be unloaded promptly without regard to jurisdictional disputes which will be handled as per the provisions of this Agreement. The Contractor will supply the Union with delivery schedules, allowing as much time as possible to insure the appropriate crafts will be available to unload the materials or equipment.

6.5 All signatory affiliates agree that upon request, a representative shall be assigned without delay to attempt a settlement in the event of a question on assignments.

ARTICLE VII - WORK STOPPAGES AND LOCKOUTS

7.1 During the term of this PLA, no Union or any of its members, officers, stewards, employees, agents or representatives shall instigate, support, sanction, maintain, or participate in any strike, picketing, walkout, work stoppage, slow down or other activity that interferes with the routine and timely prosecution of work at the Project site or at any other contractor's or supplier's facility that is necessary to performance of work at the Project site. Hand billing at the Project site during the designated lunch period and before commencement or following conclusion of the established standard workday shall not, in itself, be deemed an activity that interferes with the routine and timely prosecution of work on the Project.

- 7.2 Should any activity prohibited by paragraph 7.1 of this Article occur, the Union shall undertake all steps reasonably necessary to promptly end such prohibited activities. No Union complying with its obligations under this Article shall be liable for acts of employees for which it has no responsibility or for the unauthorized acts of employees it represents. Any employee who participates in or encourages any activity prohibited by paragraph 7.1 shall be immediately suspended from all work on the Project for a period equal to the greater of (a) 60 days; or (b) the maximum disciplinary period allowed under the applicable collective bargaining agreement for engaging in comparable unauthorized or prohibited activity.
- 7.3 During the term of this PLA, the Prime Contractor and its Subcontractors shall not engage in any lockout at the Project site of employees covered by this Agreement.
- 7.4 Upon notification of violations of this Article, the principal officer or officers of the local area Building and Construction Trades Council, and the Illinois AFL-CIO Statewide Project Labor Agreement Committee as appropriate, will immediately instruct, order and use their best efforts to cause the affiliated union or unions to cease any violations of this Article. A Trades Council and the Committee otherwise in compliance with the obligations under this paragraph shall not be liable for unauthorized acts of its affiliates.
- 7.5 In the event that activities in violation of this Article are not immediately halted through the efforts of the parties, any aggrieved party may invoke the special arbitration provisions set forth in paragraph 7.6 of this Article.
- 7.6 Upon written notice to the other involved parties by the most expeditious means available, any aggrieved party may institute the following special arbitration procedure when a breach of this Article is alleged:
- 7.6.A The party invoking this procedure shall notify the individual designated as the Permanent Arbitrator pursuant to Article III of the nature of the alleged violation; such notice shall be by the most expeditious means possible. The initiating party may also furnish such additional factual information as may be reasonably necessary for the Permanent Arbitrator to understand the relevant circumstances. Copies of any written materials provided to the arbitrator shall also be contemporaneously provided by the most expeditious means possible to the party alleged to be in violation and to all other involved parties.
- 7.6.B Upon receipt of said notice the Permanent Arbitrator shall set and hold a hearing within twenty-four (24) hours if it is contended the violation is ongoing, but not before twenty-four (24) hours after the written notice to all parties involved as required above.
- 7.6.C The Permanent Arbitrator shall notify the parties by facsimile or any other effective written means, of the place and time chosen by the Permanent Arbitrator for this hearing. Said hearing shall be completed in one session. A failure of any party or parties to attend said hearing shall not delay the hearing of evidence or issuance of an Award by the Permanent Arbitrator.

7.6.D The sole issue at the hearing shall be whether a violation of this Article has, in fact, occurred. An Award shall be issued in writing within three (3) hours after the close of the hearing, and may be issued without a written opinion. If any party desires a written opinion, one shall be issued within fifteen (15) days, but its issuance shall not delay compliance with, or enforcement of, the Award. The Permanent Arbitrator may order cessation of the violation of this Article, and such Award shall be served on all parties by hand or registered mail upon issuance.

7.6.E Such Award may be enforced by any court of competent jurisdiction upon the filing of the Award and such other relevant documents as may be required. Facsimile or other hardcopy written notice of the filing of such enforcement proceedings shall be given to the other relevant parties. In a proceeding to obtain a temporary order enforcing the Permanent Arbitrator's Award as issued under this Article, all parties waive the right to a hearing and agree that such proceedings may be ex parte. Such agreement does not waive any party's right to participate in a hearing for a final order of enforcement. The Court's order or orders enforcing the Permanent Arbitrator's Award shall be served on all parties by hand or by delivery to their last known address or by registered mail.

7.7 Individuals found to have violated the provisions of this Article are subject to immediate termination. In addition, IDOT reserves the right to terminate this PLA as to any party found to have violated the provisions of this Article.

7.8 Any rights created by statute or law governing arbitration proceedings inconsistent with the above procedure or which interfere with compliance therewith are hereby waived by parties to whom they accrue.

7.9 The fees and expenses of the Permanent Arbitrator shall be borne by the party or parties found in violation, or in the event no violation is found, such fees and expenses shall be borne by the moving party.

ARTICLE VIII – MISCELLANEOUS

8.1 If any Article or provision of this PLA shall be declared invalid, inoperative or unenforceable by operation of law or by final non-appealable order of any tribunal of competent jurisdiction, such provision shall be deemed severed or limited, but only to the extent required to render the remaining provisions of this PLA enforceable consistent with the intent of the parties. The remainder of this PLA or the application of such Article or provision to persons or circumstances other than those as to which it has been held invalid, inoperative or unenforceable shall not be affected thereby.

8.2 The term of this PLA shall commence as of and from the date of the notice of award to the Prime Contractor and shall end upon final acceptance by IDOT of all work on the Project by the parties hereto.

- 8.3 This PLA may not be changed or modified except by the subsequent written agreement of the parties. All parties represent that they have the full legal authority to enter into this PLA. This PLA may be executed by the parties in one or more counterparts.
- 8.4 Any liability arising out of this PLA shall be several and not joint. IDOT shall not be liable to any person or other party for any violation of this PLA by any other party, and no Contractor or Union shall be liable for any violation of this PLA by any other Contractor or Union.
- 8.5 The failure or refusal of a party to exercise its rights hereunder in one or more instances shall not be deemed a waiver of any such rights in respect of a separate instance of the same or similar nature.

[The Balance of This Page Intentionally Left Blank]

Execution Page

Illinois Department of Transportation

Christine M. Reed, P.E., Director of Highways

Ann Schneider, Director Finance & Administration

Ellen Schanzle-Haskins, Chief Counsel

Gary Hannig, Secretary

(Date)

Illinois AFL-CIO Statewide Project Labor Agreement Committee, representing the local unions listed below:

(Date)

List Union Locals:

**** RETURN WITH BID ****

Exhibit A – Contractor Letter of Assent

(Date)

To All Parties:

In accordance with the terms and conditions of the contract for Construction Work on [Contract 74296], this Letter of Assent hereby confirms that the undersigned Prime Contractor or Subcontractor agrees to be bound by the terms and conditions of the Project Labor Agreement established and entered into by the Illinois Department of Transportation in connection with said Project.

It is the understanding and intent of the undersigned party that this Project Labor Agreement shall pertain only to the identified Project. In the event it is necessary for the undersigned party to become signatory to a collective bargaining agreement to which it is not otherwise a party in order that it may lawfully make certain required contributions to applicable fringe benefit funds, the undersigned party hereby expressly conditions its acceptance of and limits its participation in such collective bargaining agreement to its work on the Project.

(Authorized Company Officer)

(Company)

**** RETURN WITH BID ****

STORM WATER POLLUTION PREVENTION PLAN



**Storm Water Pollution
Prevention Plan**

Route	<u>FAI 57/70</u>	Marked Rt.	<u>I-57/70</u>
Section	<u>(25-3) R,BY,BR,B</u>	Project No.	<u>N/A</u>
County	<u>Effingham</u>	Contract No.	<u>74296</u>

This plan has been prepared to comply with the provisions of the NPDES Permit Number ILR10, issued by the Illinois Environmental Protection Agency on May 30, 2003 for storm water discharges from Construction Site Activities. This plan has also been prepared to comply with the provisions of NPDES Permit Number ILR40 for discharges from small municipal separate storm sewer systems if checked below.

NPDES permits associated with this project:

- ILR10 Permit No. (if applicable): _____
- ILR40 Permit No. (if applicable): _____

I certify under penalty of law that this document and all attachments were prepared under my direction or supervision in accordance with a system designed to assure that qualified personnel properly gathered and evaluated the information submitted. Based on my inquiry of the person or persons who manage the system, or those persons directly responsible for gathering the information, the information submitted is, to the best of my knowledge and belief, true, accurate and complete. I am aware that there are significant penalties for submitting false information, including the possibility of fine and imprisonment for knowing violations.

Royal Drosskell
Print Name
Regional Engineer
Title
IDOT
Agency

Royal Drosskell
Signature
3-24-10
Date

I. Site Description:

A. The following is a description of the project location:

The work on this project is located on FAI Routes 57 and 70 and the Tri-Level Complex from West of the Little Wabash River to West of US Route 40 in Effingham County, Illinois.

- B. The following is a description of the construction activity which is the subject of this plan:

The work in this project consists of 2.1 miles of pavement reconstruction and resurfacing operations to facilitate the interstate reconstruction and resurfacing on FAI Routes 57 and 70 and the Tri-Level Complex from West of the Little Wabash River to West of US Route 40 in Effingham, Illinois.

- C. The following is a description of the intended sequence of major activities which will disturb soils for major portions of the construction site, such as grubbing, excavation and grading:

Embankment and grading operations will take place including tree removal, grubbing and clearing.

Placement, maintenance, removal and proper clean up of temporary erosion control items including perimeter erosion barrier, erosion control blankets, inlet and pipe protection, sediment basins, ditch checks, and seeding.

Placement of permanent erosion control items, seeding.

Final roadway grading, paving and other miscellaneous items including installation of guardrail.

- D. The total area of the construction site is estimated to be 170.0 acres.

The total area of the site that is estimated will be disturbed by excavation, grading or other activities is 78.0 acres.

- E. The following is a weighted average of the runoff coefficient for this project after construction activities are completed:

.42

- F. The following is a description of the soil types found at the project site followed by information regarding their erosivity:

There are five soil types located in the project area.

Atlas silt Loam. (7C2) This soil generally is moderately sloping somewhat poorly drained. Water and air move through the soil at a very rapid rate and surface runoff is rapid. Slopes are from 4 to 12 percent and are eroded.

Hickory loam (8F) This soil is steep and well drained soil. Water and air move through the soil at a moderate rate and surface runoff is rapid. Slopes are from 20 to 50 percent

Bluford silt loam (13A) This soil is poorly drained and has a slow permeability and is not subject to flooding. It has a low susceptibility to wind and to water erosion. Slopes are from 0 to 2 percent.

Ava silt loam (14B) This soil is moderately well drained and has seasonal wetness and very slow permeability Slopes are from 1 to 5 percent.

Holton silt loam (225) This soil is nearly level and a somewhat poorly drained soil. It is bottomland soil subject to frequent flooding during periods from January to June. Water and air move through this soil at a moderate rate and surface runoff is very slow.

- G. The following is a description of potentially erosive areas associated with this project:

There are no potentially critical erosive areas for this project.

- H. The following is a description of soil disturbing activities, their locations, and their erosive factors (e.g. steepness of slopes, length of slopes, etc):

The nature and purpose of land disturbing activities for this project is to reconstruct and resurface existing roadways and ramps to facilitate the upgrading of the existing facility to a six lane fully access controlled facility. The existing roadway will be profiled and regraded to enhance roadside drainage features. The slopes will be constructed at 6:3:1. Offsite land disturbing activities will be required in order to obtain fill material. This activity will be minimized and all borrow areas must be approved by IDOT. The soils in the area have a low susceptibility to water and wind erosion.

- I. See the erosion control plans and/or drainage plans for this contract for information regarding drainage patterns, approximate slopes anticipated before and after major grading activities, locations where vehicles enter or exit the site and controls to prevent offsite sediment tracking (to be added after contractor identifies locations), areas of soil disturbance, the location of major structural and non-structural controls identified in the plan, the location of areas where stabilization practices are expected to occur, surface waters (including wetlands) and locations where storm water is discharged to surface water including wetlands.
- J. The following is a list of receiving water(s) and the ultimate receiving water(s), and areal extent of wetland acreage at the site. The location of the receiving waters can be found on the erosion and sediment control plans:

Little Wabash River

K. The following pollutants of concern will be associated with this construction project:

- | | |
|--|---|
| <input checked="" type="checkbox"/> Soil Sediment | <input type="checkbox"/> Petroleum (gas, diesel, oil, kerosene, hydraulic oil / fluids) |
| <input type="checkbox"/> Concrete | <input type="checkbox"/> Antifreeze / Coolants |
| <input type="checkbox"/> Concrete Truck Waste | <input type="checkbox"/> Waste water from cleaning construction equipment |
| <input type="checkbox"/> Concrete Curing Compounds | <input type="checkbox"/> Other (specify) |
| <input type="checkbox"/> Solid Waste Debris | <input type="checkbox"/> Other (specify) |
| <input type="checkbox"/> Paints | <input type="checkbox"/> Other (specify) |
| <input type="checkbox"/> Solvents | <input type="checkbox"/> Other (specify) |
| <input type="checkbox"/> Fertilizers / Pesticides | <input type="checkbox"/> Other (specify) |

II. Controls:

This section of the plan addresses the controls that will be implemented for each of the major construction activities described in I.C. above and for all use areas, borrow sites, and waste sites. For each measure discussed, the contractor will be responsible for its implementation as indicated. The contractor shall provide to the resident engineer a plan for the implementation of the measures indicated. The contractor, and subcontractors, will notify the resident engineer of any proposed changes, maintenance, or modifications to keep construction activities compliant with the permit. Each such contractor has signed the required certification on forms which are attached to, and are a part of, this plan:

A. Erosion and Sediment Controls

1. **Stabilized Practices:** Provided below is a description of interim and permanent stabilization practices, including site specific scheduling of the implementation of the practices. Site plans will ensure that existing vegetation is preserved where attainable and disturbed portions of the site will be stabilized. Stabilization practices may include but are not limited to: temporary seeding, permanent seeding, mulching, geotextiles, sodding, vegetative buffer strips, protection of trees, preservation of mature vegetation, and other appropriate measures. Except as provided below in II(A)(1)(a) and II(A)(3), stabilization measures shall be initiated as soon as practicable in portions of the site where construction activities have temporarily or permanently ceased, but in no case more than 14 days after the construction activity in that portion of the site has temporarily or permanently ceases on all disturbed portions of the site where construction will not occur for a period of 21 or more calendar days.
 - a. Where the initiation of stabilization measures by the 14th day after construction activity temporarily or permanently ceases is precluded by snow cover, stabilization measures shall be initiated as soon as practicable thereafter.

The following Stabilization Practices will be used for this project:

- | | |
|---|--|
| <input type="checkbox"/> Preservation of Mature Vegetation | <input checked="" type="checkbox"/> Erosion Control Blanket / Mulching |
| <input type="checkbox"/> Vegetated Buffer Strips | <input type="checkbox"/> Sodding |
| <input checked="" type="checkbox"/> Protection of Trees | <input type="checkbox"/> Geotextiles |
| <input checked="" type="checkbox"/> Temporary Erosion Control Seeding | <input type="checkbox"/> Other (specify) |
| <input type="checkbox"/> Temporary Turf (Seeding, Class 7) | <input type="checkbox"/> Other (specify) |
| <input checked="" type="checkbox"/> Temporary Mulching | <input type="checkbox"/> Other (specify) |
| <input checked="" type="checkbox"/> Permanent Seeding | <input type="checkbox"/> Other (specify) |

Describe how the Stabilization Practices listed above will be utilized:

Temporary Erosion Control Seeding - This shall be applied to bare areas every seven days to minimize the amount of exposed surface areas.

Permanent Seeding- Seeding, Class 2 will be installed per IDOT specifications and as directed by the engineer.

Erosions Control Blankets/Mulching- Erosion control blankets shall be installed over fill slopes. Mulch, Method 2, shall be applied to relatively flat areas to protect the disturbed areas and prevent further erosion.

Permanent Stablization- All areas disturbed by construction will be stabilized with permanent seeding immediately following the finished grading. Erosion control blankets shall be installed over fill slopes which have been brought to final grade and have been seeded to protect the slopes from rill and gully erosion and to allow seed to germinate properly.

- 2. Structural Practices:** Provided below is a description of structural practices that will be implemented, to the degree attainable, to divert flows from exposed soils, store flows or otherwise limit runoff and the discharge of pollutants from exposed areas of the site. Such practices may include but are not limited to: perimeter erosion barrier, earth dikes, drainage swales, sediment traps, ditch checks, subsurface drains, pipe slope drains, level spreaders, storm drain inlet protection, rock outlet protection, reinforced soil retaining systems, gabions, and temporary or permanent sediment basins. The installation of these devices may be subject to Section 404 of the Clean Water Act.

The following Structural Practices will be used for this project:

- | | |
|--|--|
| <input checked="" type="checkbox"/> Perimeter Erosion Barrier | <input type="checkbox"/> Rock Outlet Protection |
| <input checked="" type="checkbox"/> Temporary Ditch Check | <input checked="" type="checkbox"/> Riprap |
| <input checked="" type="checkbox"/> Storm Drain Inlet Protection | <input type="checkbox"/> Gabions |
| <input type="checkbox"/> Sediment Trap | <input type="checkbox"/> Slope Mattress |
| <input type="checkbox"/> Temporary Pipe Slope Drain | <input type="checkbox"/> Retaining Walls |
| <input checked="" type="checkbox"/> Temporary Sediment Basin | <input type="checkbox"/> Slope Walls |
| <input type="checkbox"/> Temporary Stream Crossing | <input type="checkbox"/> Concrete Revetment Mats |
| <input type="checkbox"/> Stabilized Construction Exits | <input type="checkbox"/> Level Spreaders |

- | | |
|---|--|
| <input type="checkbox"/> Turf Reinforcement Mats | <input type="checkbox"/> Other (specify) |
| <input type="checkbox"/> Permanent Check Dams | <input type="checkbox"/> Other (specify) |
| <input type="checkbox"/> Permanent Sediment Basin | <input type="checkbox"/> Other (specify) |
| <input type="checkbox"/> Aggregate Ditch | <input type="checkbox"/> Other (specify) |
| <input type="checkbox"/> Paved Ditch | <input type="checkbox"/> Other (specify) |

Describe how the Structural Practices listed above will be utilized:

Perimeter Erosion Barrier- Silt fences will be placed along the project in an effort to contain silt and runoff from leaving the site.

Temporary Ditch Checks- Ditch checks will be placed in swales where runoff velocity is high. All structural practices are shown in detail on the erosion control plan.

Storm Drain Inlet Protection- Inlet and pipe protection will be provided for culverts and storm sewers

Sediment Basin- A sediment basin will be constructed at locations where channelized flow is leaving the project limits.

Riprap- Stone riprap with filter fabric as inlet/outlet protection to prevent scouring at the end of the pipes and to prevent erosion of ditches with steep grades or high velocities.

3. Storm Water Management: Provided below is a description of measures that will be installed during the construction process to control pollutants in storm water discharges that will occur after construction operations have been completed. The installation of these devices may be subject to Section 404 of the Clean Water Act.

- a. Such practices may include but are not limited to: storm water detention structures (including wet ponds), storm water retention structures, flow attenuation by use of open vegetated swales and natural depressions, infiltration of runoff on site, and sequential systems (which combine several practices).

The practices selected for implementation were determined on the basis of the technical guidance in Section 59-8 (Erosion and Sediment Control) in Chapter 59 (Landscape Design and Erosion Control) of the Illinois Department of Transportation Bureau of Design and Environment Manual. If practices other than those discussed in Section 59-8 are selected for implementation or if practices are applied to situations different from those covered in Section 59-8, the technical basis for such decisions will be explained below.

- b. Velocity dissipation devices will be placed at discharge locations and along the length of any outfall channel as necessary to provide a non-erosive velocity flow from the structure to a water course so that the

natural physical and biological characteristics and functions are maintained and protected (e.g. maintenance of hydrologic conditions such as the hydroperiod and hydrodynamics present prior to the initiation of construction activities).

Description of Storm Water Management Controls.

There are no required Storm Water Management Controls for this project.

4. Other Controls:

- a. Vehicle Entrances and Exits – Stabilized construction entrances and exits must be constructed to prevent tracking of sediments onto roadways.

The contractor will provide the resident engineer with a written plan identifying the location of stabilized entrances and exits and the procedures (s)he will use to construct and maintain them.

- b. Material Delivery, Storage, and Use – The following BMPs shall be implemented to help prevent discharges of construction materials during delivery, storage, and use:

- All products delivered to the project site must be properly labeled.
- Water tight shipping containers and/or semi trailers shall be used to store hand tools, small parts, and most construction materials that can be carried by hand, such as paint cans, solvents, and grease.
- A storage/containment facility should be chosen for larger items such as drums and items shipped or stored on pallets. Such material is to be covered by a tin roof or large sheets of plastic to prevent precipitation from coming in contact with the products being stored.
- Large items such as light stands, framing materials and lumber shall be stored in the open in a general storage area. Such material shall be elevated with wood blocks to minimize contact with storm water runoff.
- Spill clean-up materials, material safety data sheets, an inventory of materials, and emergency contact numbers shall be maintained and stored in one designated area and each Contractor is to inform his/her employees and the resident engineer of this location.

- c. Stockpile Management – BMPs shall be implemented to reduce or eliminate pollution of storm water from stockpiles of soil and paving materials such as but not limited to portland cement concrete rubble, asphalt concrete, asphalt concrete rubble, aggregate base, aggregate sub base, and pre-mixed aggregate. The following BMPs may be considered:

- Perimeter Erosion Barrier
- Temporary Seeding
- Temporary Mulch
- Plastic Covers
- Soil Binders
- Storm Drain Inlet Protection

The contractor will provide the resident engineer with a written plan of the procedures (s)he will use on the project and how they will be maintained.

- d. Waste Disposal. No materials, including building materials, shall be discharged into Waters of the State, except as authorized by a Section 404 permit.
- e. The provisions of this plan shall ensure and demonstrate compliance with applicable State and/or local waste disposal, sanitary sewer or septic system regulations.
- f. The contractor shall provide a written and graphic plan to the resident engineer identifying where each of the above areas will be located and how they are to be managed.

5. Approved State or Local Laws

The management practices, controls and provisions contained in this plan will be in accordance with IDOT specifications, which are at least as protective as the requirements contained in the Illinois Environmental Protection Agency's Illinois Urban Manual, 1995. Procedures and requirements specified in applicable sediment and erosion site plans or storm water management plans approved by local officials shall be described or incorporated by reference in the space provided below. Requirements specified in sediment and erosion site plans, site permits, storm water management site plans or site permits approved by local officials that are applicable to protecting surface water resources are, upon submittal of an NOI, to be authorized to discharge under permit ILR10 incorporated by reference and are enforceable under this permit even if they are not specifically included in the plan.

Description of procedures and requirements specified in applicable sediment and erosion site plans or storm water management plans approved by local officials:

All management practices, controls and other provisions provided in this plan are in accordance with the IDOT Standard Specifications for Road and Bridge Construction and the Illinois Urban Manual.

III. Maintenance:

The following is a description of procedures that will be used to maintain, in good and effective operating conditions, the vegetation, erosion and sediment control measures and other protective measures identified in this plan. The resident engineer will provide maintenance guides to the contractor for the practices associated with this project.

Seeding- all erodible bare earth will be temporarily seeded every 7 days to minimize the amount of erodible surfaces within the contract limits.

Perimeter Erosion Barrier- Sediment will be removed if the integrity of the fencing is in jeopardy and any fencing knocked down will be repaired immediately.

Erosion Control Blanket/Mulching- Any areas that fail will be repaired immediately.

Ditch Checks- Sediment will be removed if the integrity of the ditch check is in jeopardy and any ditch checks which fail will be repaired or replaced immediately.

IV. Inspections:

Qualified personnel shall inspect disturbed areas of the construction site which have not yet been finally stabilized, structural control measures, and locations where vehicles and equipment enter and exit the site. Such inspections shall be conducted at least once every seven (7) calendar days and within 24 hours of the end of a storm that is 0.5 inches or greater or equivalent snowfall.

- A. Disturbed areas, use areas (storage of materials, stockpiles, machine maintenance, fueling, etc.), borrow sites, and waste sites shall be inspected for evidence of, or the potential for, pollutants entering the drainage system. Erosion and sediment control measures identified in the plan shall be observed to ensure that they are operating correctly. Discharge locations or points that are accessible, shall be inspected to ascertain whether erosion control measures are effective in preventing significant impacts to receiving waters. Locations where vehicles enter or exit the site shall be inspected for evidence of off site sediment tracking.
- B. Based on the results of the inspection, the description of potential pollutant sources identified in section I above and pollution prevention measures identified in section II above shall be revised as appropriate as soon as practicable after such inspection. Any changes to this plan resulting from the required inspections shall be implemented within ½ hour to 1 week based on the urgency of the situation. The resident engineer will notify the contractor of the time required to implement such actions through the weekly inspection report.
- C. A report summarizing the scope of the inspection, name(s) and qualifications of personnel making the inspection, the date(s) of the inspection, major observations relating to the implementation of this storm water pollution prevention plan, and actions taken in accordance with section IV(B) shall be made and retained as part of the plan for at least three (3) years after the date

of the inspection. The report shall be signed in accordance with Part VI. G of the general permit.

- D. If any violation of the provisions of this plan is identified during the conduct of the construction work covered by this plan, the resident engineer shall complete and file an "Incidence of Noncompliance" (ION) report for the identified violation. The resident engineer shall use forms provided by the Illinois Environmental Protection Agency and shall include specific information on the cause of noncompliance, actions which were taken to prevent any further causes of noncompliance, and a statement detailing any environmental impact which may have resulted from the noncompliance. All reports of noncompliance shall be signed by a responsible authority in accordance with Part VI. G of the general permit.

The Incidence of Non-Compliance shall be mailed to the following address:

Illinois Environmental Protection Agency
Division of Water Pollution Control
Attn: Compliance Assurance Section
1021 North Grand East
Post Office Box 19276
Springfield, Illinois 62794-9276

V. Non-Storm Water Discharges:

Except for flows from fire fighting activities, sources of non-storm water that is combined with storm water discharges associated with the industrial activity addressed in this plan must be described below. Appropriate pollution prevention measures, as described below, will be implemented for the non-storm water component(s) of the discharge.

- A. Spill Prevention and Control – BMPs shall be implemented to contain and clean-up spills and prevent material discharges to the storm drain system. The contractor shall produce a written plan stating how his/her company will prevent, report, and clean up spills and provide a copy to all of his/her employees and the resident engineer. The contractor shall notify all of his/her employees on the proper protocol for reporting spills. The contractor shall notify the resident engineer of any spills immediately.
- B. Concrete Residuals and Washout Wastes – The following BMPs shall be implemented to control residual concrete, concrete sediments, and rinse water:
- Temporary Concrete Washout Facilities shall be constructed for rinsing out concrete trucks. Signs shall be installed directing concrete truck drivers where designated washout facilities are located.
 - The contractor shall have the location of temporary concrete washout facilities approved by the resident engineer.

- All temporary concrete washout facilities are to be inspected by the contractor after each use and all spills must be reported to the resident engineer and cleaned up immediately.
 - Concrete waste solids/liquids shall be disposed of properly.
- C. Litter Management – A proper number of dumpsters shall be provided on site to handle debris and litter associated with the project. The Contractor is responsible for ensuring his/her employees place all litter including marking paint cans, soda cans, food wrappers, wood lathe, marking ribbon, construction string, and all other construction related litter in the proper dumpsters.
- D. Vehicle and Equipment Cleaning – Vehicles and equipment are to be cleaned in designated areas only, preferably off site.
- E. Vehicle and Equipment Fueling – A variety of BMPs can be implemented during fueling of vehicles and equipment to prevent pollution. The contractor shall inform the resident engineer as to which BMPs will be used on the project. The contractor shall inform the resident engineer how (s)he will be informing his/her employees of these BMPs (i.e. signs, training, etc.). Below are a few examples of these BMPs:
- Containment
 - Spill Prevention and Control
 - Use of Drip Pans and Absorbents
 - Automatic Shut-Off Nozzles
 - Topping Off Restrictions
 - Leak Inspection and Repair
- F. Vehicle and Equipment Maintenance – On site maintenance must be performed in accordance with all environmental laws such as proper storage and no dumping of old engine oil or other fluids on site.

VI. Failure to Comply:

Failure to comply with any provisions of this Storm Water Pollution Prevention Plan will result in the implementation of an Erosion and Sediment Control Deficiency Deduction against the contractor and/or penalties under the NPDES permit which could be passed onto the contractor.

ROCKFILL - REPLACEMENT

Effective July 2007

This work consists of the removal and replacement of unsuitable soils beneath cast-in-place and precast concrete box culverts.

Materials shall meet the requirements of the following Articles of the Standard Specifications:

Item	Article
CA 07	1004.04 ^a
Rockfill	1005.01

^a Except coarse aggregate shall be crushed and quality shall be as directed by the Engineer.

The gradation of rockfill shall be selected based on the following table:

Rockfill Layer Thickness	Rockfill Gradation	Minimum Cap Thickness
Less than 1 ft	Gradations with a maximum size of 4 inches approved by the Engineer. ^b	4 inches
Greater than 1 ft	Primary Crusher Run	6 inches
Greater than 3 ft	Primary Crusher Run or Shot Rock ^c	6 inches

^b Gradations with a maximum size of 2 inches or smaller shall have less than 6% passing the No. 200 sieve.

^c Shot rock dimensions shall not exceed 18 inches.

Unsuitable soil shall be excavated according to Article 202.03 of the Standard Specifications. Rockfill shall be placed following the excavation of the unsuitable soil. No compaction of rockfill is required. For cast-in-place concrete box culverts, rockfill shall be capped with CA 07. For precast concrete box culverts, the rockfill shall be capped with the porous granular bedding according to Article 540.06 of the Standard Specifications, except only CA 07 will be allowed.

This work will be measured and paid for at the contract unit price per ton for ROCKFILL - REPLACEMENT and per cubic yard for REMOVAL AND DISPOSAL OF UNSUITABLE MATERIAL. For precast concrete box culverts, porous granular bedding material and the excavation required for bedding will be paid for according to Article 540.08 of the Standard Specifications.

ILLINOIS DEPARTMENT OF LABOR

PREVAILING WAGES FOR EFFINGHAM COUNTY EFFECTIVE JULY 2010

The Prevailing rates of wages are included in the Contract proposals which are subject to Check Sheet #5 of the Supplemental Specifications and Recurring Special Provisions. The rates have been ascertained and certified by the Illinois Department of Labor for the locality in which the work is to be performed and for each craft or type of work or mechanic needed to execute the work of the Contract. As required by Prevailing Wage Act (820 ILCS 130/0.01, et seq.) and Check Sheet #5 of the Contract, not less than the rates of wages ascertained by the Illinois Department of Labor and as revised during the performance of a Contract shall be paid to all laborers, workers and mechanics performing work under the Contract. Post the scale of wages in a prominent and easily accessible place at the site of work.

If the Illinois Department of Labor revises the prevailing rates of wages to be paid as listed in the specification of rates, the contractor shall post the revised rates of wages and shall pay not less than the revised rates of wages. Current wage rate information shall be obtained by visiting the Illinois Department of Labor web site at <http://www.state.il.us/agency/idol/> or by calling 312-793-2814. It is the responsibility of the contractor to review the rates applicable to the work of the contract at regular intervals in order to insure the timely payment of current rates. Provision of this information to the contractor by means of the Illinois Department of Labor web site satisfies the notification of revisions by the Department to the contractor pursuant to the Act, and the contractor agrees that no additional notice is required. The contractor shall notify each of its subcontractors of the revised rates of wages.

Effingham County Prevailing Wage for July 2010

Trade Name	RG	TYP	C	Base	FRMAN	*M-F>8	OSA	OSH	H/W	Pensn	Vac	Trng
=====	==	===	=	=====	=====	=====	===	===	=====	=====	=====	=====
ASBESTOS ABT-GEN		ALL		23.650	24.100	1.5	1.5	2.0	5.450	8.500	0.000	0.900
ASBESTOS ABT-MEC		BLD		20.800	0.000	2.0	2.0	2.0	5.500	4.200	0.000	0.000
BOILERMAKER		BLD		31.500	34.000	1.5	1.5	2.0	6.820	11.43	1.500	0.350
BRICK MASON		BLD		28.010	29.510	2.0	2.0	2.0	5.900	7.830	0.000	0.630
CARPENTER		BLD		29.000	31.250	1.5	1.5	2.0	7.250	10.30	0.000	0.320
CARPENTER		HWY		26.910	28.660	1.5	1.5	2.0	7.250	10.30	0.000	0.320
CEMENT MASON		BLD		29.480	30.980	1.5	1.5	2.0	5.900	7.880	0.000	0.500
CEMENT MASON		HWY		25.580	27.080	1.5	1.5	2.0	5.900	5.000	0.000	0.300
CERAMIC TILE FNSHER		BLD		28.100	0.000	1.5	1.5	2.0	5.900	7.430	0.000	0.000
ELECTRICIAN	N	BLD		33.220	36.540	1.5	1.5	2.0	5.250	6.530	0.000	0.490
ELECTRICIAN	S	ALL		35.750	38.000	1.5	1.5	2.0	5.250	8.220	0.000	0.540
ELECTRONIC SYS TECH	N	BLD		29.390	31.140	1.5	1.5	2.0	5.250	4.730	0.000	0.250
ELECTRONIC SYS TECH	S	BLD		29.530	31.280	1.5	1.5	2.0	5.250	3.840	0.000	0.250
ELEVATOR CONSTRUCTOR		BLD		37.850	42.580	2.0	2.0	2.0	10.03	9.460	2.270	0.000
GLAZIER		BLD		29.880	31.630	1.5	2.0	2.0	6.030	6.650	0.000	0.330
HT/FROST INSULATOR		BLD		28.920	29.920	1.5	1.5	2.0	4.800	8.160	0.000	0.280
IRON WORKER		ALL		27.500	30.250	1.5	1.5	2.0	6.200	10.70	0.000	0.300
LABORER		BLD		23.650	24.100	1.5	1.5	2.0	5.450	8.500	0.000	0.800
LABORER		HWY		23.650	24.100	1.5	1.5	2.0	5.450	8.450	0.000	0.800
LATHER		BLD		29.000	31.250	1.5	1.5	2.0	7.250	10.30	0.000	0.320
MACHINIST		BLD		42.770	44.770	1.5	1.5	2.0	7.750	8.690	0.650	0.000
MARBLE FINISHERS		BLD		28.100	0.000	1.5	1.5	2.0	5.900	7.430	0.000	0.000
MARBLE MASON		BLD		29.600	0.000	1.5	1.5	2.0	5.900	7.430	0.000	0.000
MILLWRIGHT		BLD		29.020	31.270	1.5	1.5	2.0	7.250	10.74	0.000	0.320
MILLWRIGHT		HWY		29.260	31.010	1.5	1.5	2.0	6.750	9.050	0.000	0.320
OPERATING ENGINEER	ALL	1		33.350	0.000	1.5	1.5	2.0	5.750	7.500	0.000	0.700
OPERATING ENGINEER	ALL	2		21.800	0.000	1.5	1.5	2.0	5.750	7.500	0.000	0.700
PAINTER		ALL		26.000	27.500	1.5	1.5	2.0	7.050	8.230	0.000	0.450
PILEDRIVER		BLD		29.500	31.750	1.5	1.5	2.0	7.250	10.30	0.000	0.320
PILEDRIVER		HWY		27.910	29.660	1.5	1.5	2.0	7.250	10.30	0.000	0.320
PIPEFITTER		BLD		36.860	39.360	1.5	1.5	2.0	6.700	8.770	0.000	0.920
PLASTERER		BLD		29.470	31.470	1.5	1.5	2.0	5.900	8.500	0.000	0.500
PLUMBER		BLD		36.860	39.360	1.5	1.5	2.0	6.700	8.770	0.000	0.920
ROOFER		BLD		24.550	27.050	1.5	1.5	2.0	7.800	6.050	0.000	0.550
SHEETMETAL WORKER		ALL		28.080	29.580	1.5	1.5	2.0	6.350	5.650	1.690	0.260
SPRINKLER FITTER		BLD		36.140	38.890	1.5	1.5	2.0	8.200	6.550	0.000	0.250
STONE MASON		BLD		28.010	29.510	2.0	2.0	2.0	5.900	7.830	0.000	0.630
TERRAZZO FINISHER		BLD		28.100	0.000	1.5	1.5	2.0	5.900	7.430	0.000	0.000
TERRAZZO MASON		BLD		29.600	0.000	1.5	1.5	2.0	5.900	7.430	0.000	0.000
TILE LAYER		BLD		27.150	29.150	1.5	1.5	2.0	6.750	6.800	0.000	0.320
TILE MASON		BLD		29.600	0.000	1.5	1.5	2.0	5.900	7.430	0.000	0.000
TRUCK DRIVER	ALL	1		28.487	0.000	1.5	1.5	2.0	9.050	4.062	0.000	0.250
TRUCK DRIVER	ALL	2		28.887	0.000	1.5	1.5	2.0	9.050	4.062	0.000	0.250
TRUCK DRIVER	ALL	3		29.087	0.000	1.5	1.5	2.0	9.050	4.062	0.000	0.250
TRUCK DRIVER	ALL	4		29.337	0.000	1.5	1.5	2.0	9.050	4.062	0.000	0.250
TRUCK DRIVER	ALL	5		30.087	0.000	1.5	1.5	2.0	9.050	4.062	0.000	0.250
TUCKPOINTS		BLD		28.010	29.510	2.0	2.0	2.0	5.900	7.830	0.000	0.630

Legend:

M-F>8 (Overtime is required for any hour greater than 8 worked each day, Monday through Friday.)

OSA (Overtime is required for every hour worked on Saturday)

OSH (Overtime is required for every hour worked on Sunday and Holidays)

H/W (Health & Welfare Insurance)

Pensn (Pension)

Vac (Vacation)

Trng (Training)

Explanations

EFFINGHAM COUNTY

ELECTRICIANS AND ELECTRONIC SYSTEMS TECHNICIAN (NORTH) - Townships of Banner, Bishop, Douglas, Liberty, Lucas, Moccasin, St. Francis, Summit and Teutopolis.

ELECTRICIANS AND ELECTRONIC SYSTEMS TECHNICIAN (SOUTH) - Those townships not included in NORTH.

The following list is considered as those days for which holiday rates of wages for work performed apply: New Years Day, Memorial/Decoration Day, Fourth of July, Labor Day, Veterans Day, Thanksgiving Day, Christmas Day. Generally, any of these holidays which fall on a Sunday is celebrated on the following Monday. This then makes work performed on that Monday payable at the appropriate overtime rate for holiday pay. Common practice in a given local may alter certain days of celebration such as the day after Thanksgiving for Veterans Day. If in doubt, please check with IDOL.

EXPLANATION OF CLASSES

ASBESTOS - GENERAL - removal of asbestos material/mold and hazardous materials from any place in a building, including mechanical systems where those mechanical systems are to be removed. This includes the removal of asbestos materials/mold and hazardous materials from ductwork or pipes in a building when the building is to be demolished at the time or at some close future date.

ASBESTOS - MECHANICAL - removal of asbestos material from mechanical systems, such as pipes, ducts, and boilers, where the mechanical systems are to remain.

CERAMIC TILE FINISHER, MARBLE FINISHER, TERRAZZO FINISHER

Assisting, helping or supporting the tile, marble and terrazzo mechanic by performing their historic and traditional work assignments required to complete the proper installation of the work covered by said crafts. The term "Ceramic" is used for naming the classification only and is in no way a limitation of the product handled. Ceramic takes into consideration most hard tiles.

ELECTRONIC SYSTEMS TECHNICIAN

Installation, service and maintenance of low-voltage systems which utilizes the transmission and/or transference of voice, sound, vision, or digital for commercial, education, security and entertainment purposes for the following: TV monitoring and surveillance, background/foreground music, intercom and telephone interconnect, field programming, inventory control systems, microwave transmission,

multi-media, multiplex, radio page, school, intercom and sound burglar alarms and low voltage master clock systems.

Excluded from this classification are energy management systems, life safety systems, supervisory controls and data acquisition systems not intrinsic with the above listed systems, fire alarm systems, nurse call systems and raceways exceeding fifteen feet in length.

TRUCK DRIVER - BUILDING, HEAVY AND HIGHWAY CONSTRUCTION

Class 1. Drivers on 2 axle trucks hauling less than 9 ton. Air compressor and welding machines and brooms, including those pulled by separate units, truck driver helpers, warehouse employees, mechanic helpers, greasers and tiremen, pickup trucks when hauling materials, tools, or workers to and from and on-the-job site, and fork lifts up to 6,000 lb. capacity.

Class 2. Two or three axle trucks hauling more than 9 ton but hauling less than 16 ton. A-frame winch trucks, hydrolift trucks, vactor trucks or similar equipment when used for transportation purposes. Fork lifts over 6,000 lb. capacity, winch trucks, four axle combination units, and ticket writers.

Class 3. Two, three or four axle trucks hauling 16 ton or more. Drivers on water pulls, articulated dump trucks, mechanics and working forepersons, and dispatchers. Five axle or more combination units.

Class 4. Low Boy and Oil Distributors.

Class 5. Drivers who require special protective clothing while employed on hazardous waste work.

OPERATING ENGINEERS - BUILDING, HEAVY AND HIGHWAY CONSTRUCTION

Class 1. Power Cranes, Draglines, Derricks, Shovels, Gradalls, Mechanics, Tractor Highlift, Tournadozer, Concrete Mixers with Skip, Tournamixer, Two Drum Machine, One Drum Hoist with Tower or Boom, Cableways, Tower Machines, Motor Patrol, Boom Tractor, Boom or Winch Truck, Winch or Hydraulic Boom Truck, Truck Crane, Tournapull, Tractor Operating Scoops, Bulldozer, Push Tractor, Asphalt Planer, Finishing Machine on Asphalt, Large Rollers on Earth, Rollers on Asphalt Mix, Ross Carrier or similar Machine, Gravel Processing Machine, Asphalt Plant Engineer, Paver Operator, Dredging Equipment, or Dredge Engineer, or Dredge Operator, Central Mix Plant Engineer, CMI or similar type machine, Concrete Pump, Truck or Skid Mounted, Tower Crane, Engineer or Rock Crusher Plant, Concrete Plant Engineer, Ditching Machine with dual attachment, Tractor Mounted Loaders, Cherry Picker, Hydro Crane, Standard or Dinkey Locomotives, Scoopmobiles, Euclid Loader, Soil Cement Machine, Back Filler, Elevating Machine, Power Blade, Drilling Machine, including Well Testing, Caissons, Shaft or any similar type drilling machines, Motor Driven Paint Machine, Pipe Cleaning Machine, Pipe Wrapping Machine, Pipe Bending Machine, Apsco Paver, Boring Machine, (Head Equipment Greaser), Barber-Greene Loaders, Formless Paver, (Well Point System), Concrete Spreader, Hydra Ax, Span Saw, Marine Scoops, Brush Mulcher, Brush Burner, Mesh Placer, Tree Mover, Helicopter Crew (3), Piledriver-Skid or Crawler, Stump Remover, Root Rake, Tug Boat Operator, Refrigerating Machine, Freezing Operator, Chair Cart-Self-Propelled, Hydra Seeder, Straw Blower, Power Sub Grader, Bull Float, Finishing Machine, Self-Propelled Pavement Breaker, Lull (or similar type Machine), Two Air Compressors, Compressors hooked in Manifold, Overhead Crane, Chip Spreader, Mud Cat, Sull-Air, Fork Lifts (except when used for landscaping work), Soil Stabilizer (Seaman Tiller, Bo Mag, Rago Gator, and similar types of equipment), Tube

Float, Spray Machine, Curing Machine, Concrete or Asphalt Milling Machine, Snooper Truck-Operator, Backhoe, Farm Tractors (with attachments), 4 Point Lift System (Power Lift or similar type), Skid-Steer (Bob Cat or similar type), Wrecking Shears, Water Blaster.

Class 2. Concrete Mixers without Skips, Rock Crusher, Ditching Machine under 6', Curbing Machine, One Drum Machines without Tower or Boom, Air Tugger, Self-Propelled Concrete Saw, Machine Mounted Post Hole Digger, two to four Generators, Water Pumps or Welding Machines, within 400 feet, Air Compressor 600 cu. ft. and under, Rollers on Aggregate and Seal Coat Surfaces, Fork Lift (when used for landscaping work), Concrete and Blacktop Curb Machine, One Water Pump, Oilers, Air Valves or Steam Valves, One Welding Machine, Truck Jack, Mud Jack, Gunnite Machine, House Elevators when used for hoisting material, Engine Tenders, Fireman, Wagon Drill, Flex Plane, Conveyor, Siphons and Pulsometer, Switchman, Fireman on Paint Pots, Fireman on Asphalt Plants, Distributor Operator on Trucks, Tampers, Self-Propelled Power Broom, Striping Machine (motor driven), Form Tamper, Bulk Cement Plant, Equipment Greaser, Deck Hands, Truck Crane Oiler-Driver, Cement Blimps, Form Grader, Temporary Heat, Throttle Valve, Super Sucker (and similar type of equipment).

Other Classifications of Work:

For definitions of classifications not otherwise set out, the Department generally has on file such definitions which are available. If a task to be performed is not subject to one of the classifications of pay set out, the Department will upon being contacted state which neighboring county has such a classification and provide such rate, such rate being deemed to exist by reference in this document. If no neighboring county rate applies to the task, the Department shall undertake a special determination, such special determination being then deemed to have existed under this determination. If a project requires these, or any classification not listed, please contact IDOL at 217-782-1710 for wage rates or clarifications.

LANDSCAPING

Landscaping work falls under the existing classifications for laborer, operating engineer and truck driver. The work performed by landscape plantsman and landscape laborer is covered by the existing classification of laborer. The work performed by landscape operators (regardless of equipment used or its size) is covered by the classifications of operating engineer. The work performed by landscape truck drivers (regardless of size of truck driven) is covered by the classifications of truck driver.