

PROPOSED ROADWAY A SUPERELEVATED SECTION

STA 2069+95.07 TO STA 2084+40.31 (RDWY A, FAI 70 WB, FAI 57 SB)

**LEGEND**

- ① PROPOSED SLAG MODIFIED PORTLAND CEMENT MODIFIED SOIL 12"
- ② PROPOSED STABILIZED SUB-BASE 4"
- ③ PROPOSED CONTINUOUSLY REINFORCED PCC PAVEMENT 13"
- ④ PROPOSED PAVEMENT REINFORCEMENT 13"
- ⑤ PROPOSED AGGREGATE SHOULDERS, TYPE B 6"
- ⑥ PROPOSED PIPE UNDERDRAINS 6"
- ⑦ PROPOSED CONCRETE MEDIAN SURFACE, 6" (SPECIAL)
- ⑧ PROPOSED COMBINATION CONCRETE CURB & GUTTER, TYPE B-6.24
- ⑨ PROPOSED CONCRETE BARRIER, DOUBLE FACE, 42 INCH HEIGHT
- ⑩ PROPOSED STEEL PLATE BEAM GUARD RAIL, TYPE A
- ⑪ PROPOSED STORM SEWERS, CLASS A
- ⑫ PROPOSED PIPE UNDERDRAINS 4"
- ⑬ PROPOSED WIDE FLANGE BEAM TERMINAL JOINT
- ⑭ PROPOSED TOPSOIL 4"
- ⑮ PROPOSED PCC PAVEMENT 10" (JOINTED)
- ⑯ PROPOSED BITUMINOUS MATERIALS (PRIME COAT)
- ⑰ PROPOSED AGGREGATE (PRIME COAT)
- ⑱ PROPOSED POLYMERIZED HOT-MIX ASPHALT SURFACE COURSE, MIX "E", N105 2" AND VARIES
- ⑲ PROPOSED HOT-MIX ASPHALT SHOULDERS, 2" AND VARIES
- ⑳ PROPOSED COARSE AGGREGATE
- ㉑ PROPOSED CONCRETE BARRIER BASE
- ㉒ PROPOSED CONCRETE BARRIER, VARIABLE CROSS SECTION 42" HEIGHT
- ㉓ PROPOSED AGGREGATE WEDGE SHOULDERS, TYPE B
- ㉔ PROPOSED LIME MODIFIED SOIL 12"
- ㉕ PROPOSED SUB-BASE GRANULAR MATERIAL, TYPE B

SEE LEGEND NOS. ③ - ④ FOR PAVEMENT COMPOSITION OF SHOULDERS AND DRIVING LANES

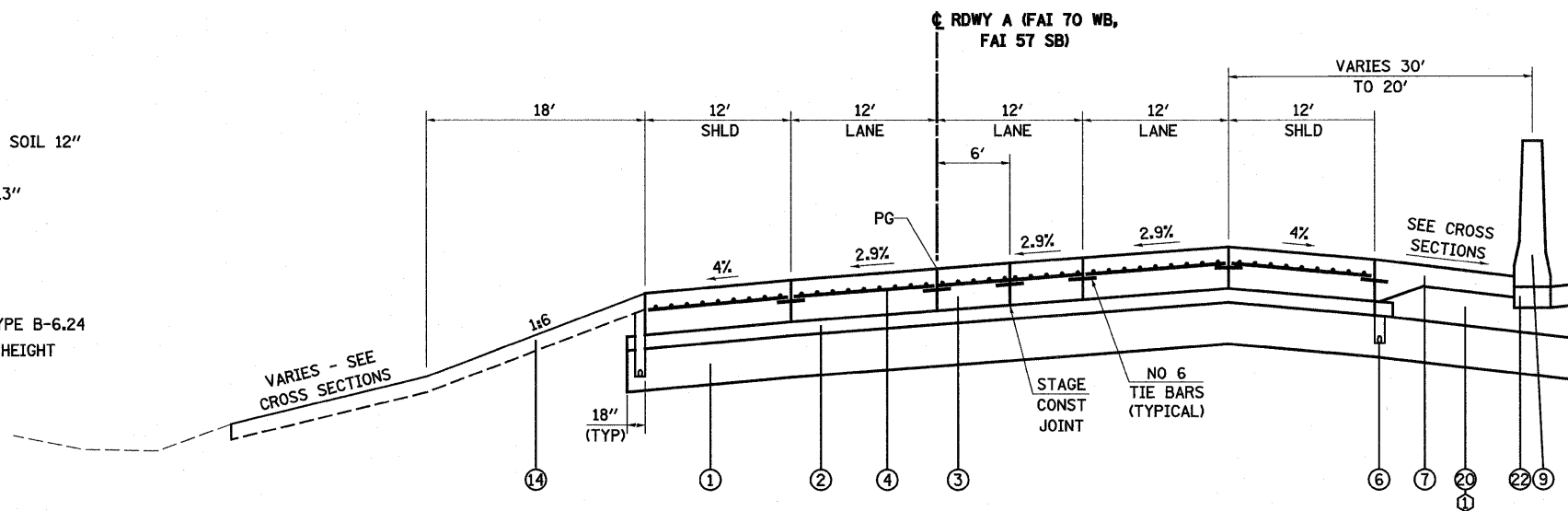

PROPOSED ROADWAY A SUPERELEVATED SECTION

STA 2084+40.31 TO STA 2089+78.76 (RDWY A, FAI 70 WB, FAI 57 SB)

STATION EQUATION - STA 2089+78.76, RDWY A = STA 2090+18.51, MAINLINE FAI RTE 57/70

- ① COARSE AGGREGATE SHALL BE GRADATION CA-7 COMPACTED TO THE SATISFACTION OF THE ENGINEER. COST INCLUDED IN CONCRETE MEDIAN SURFACE, 6" (SPECIAL)

NOTES  
PROPOSED SIDE SLOPES/DITCHES VARY - SEE CROSS SECTIONS

LIMITS OF PROPOSED TOPSOIL VARIES - SEE CROSS SECTIONS

PAVEMENT JOINTS OPTIONAL - LONGITUDINAL CONSTRUCTION JOINT OR LONGITUDINAL SAWED JOINT

FILE NAME =	USER NAME = paul	DESIGNED - JWS	REVISED -	<b>STATE OF ILLINOIS DEPARTMENT OF TRANSPORTATION</b>	<b>PROPOSED TYPICAL SECTIONS - SOUTH TRI-LEVEL</b>			F.A.I. RTE.	SECTION	COUNTY	TOTAL SHEETS	SHEET NO.	
5/1/2010 10:00:00 AM		DRAWN - RCB	REVISED -					57/70	(25-3)R	EFFINGHAM	1416	145	
PLOT SCALE = 1/8" = 1' / IN.		CHECKED - BRM	REVISED -		SCALE: 1"=50'			SHEET NO. 10 OF 18 SHEETS		STA. TO STA.		CONTRACT NO. 74296	
PLOT DATE = 2/11/2010		DATE - 3-04-08	REVISED -		FED. ROAD DIST. NO.		ILLINOIS FED. AID PROJECT						