

**EXISTING TANGENT SECTION**

STA. 424+25.00 TO STA. 431+00.00

**LEGEND**

- ① EXISTING PAVEMENT
- ② EXISTING HMA SURFACE COURSE, 1 1/2"
- ③ EXISTING HMA WIDENING
- ④ EXISTING HMA SHOULDER
- ⑤ PROPOSED BITUMINOUS MATERIAL (PRIME COAT)
- ⑥ PROPOSED AGGREGATE (PRIME COAT)
- ⑦ PROPOSED LEVELING BINDER, MIX C, 3/4"
- ⑧ PROPOSED HMA BINDER COURSE, MIX D, (VARIES 2" to 8 1/2")
- ⑨ PROPOSED HMA SURFACE COURSE 1 1/2"
- ⑩ PROPOSED HMA SHOULDERS
- ⑪ PROPOSED AGGREGATE SHOULDERS, TYPE B

HMA SURFACE REMOVAL (VARIABLE DEPTH)

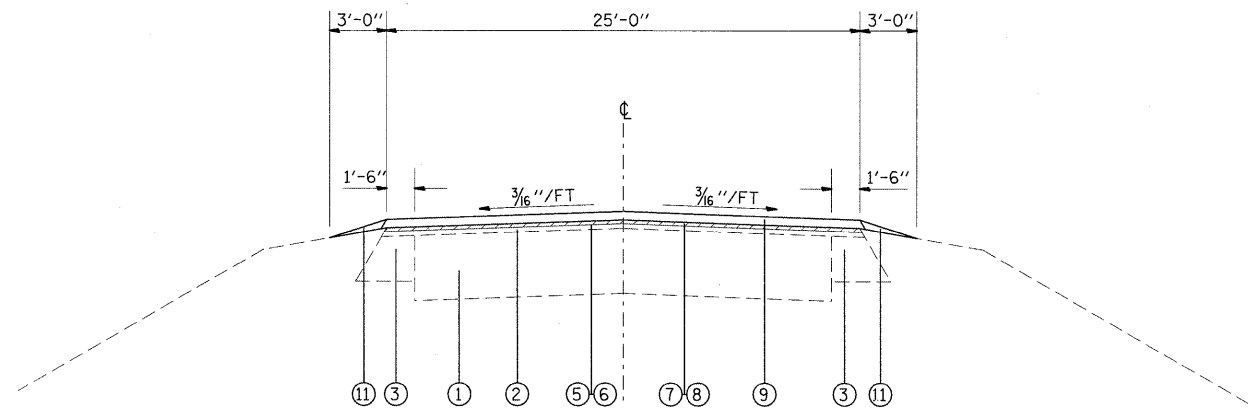

**PROPOSED TANGENT SECTION**

STA. 424+25.00 TO STA. 431+00.00

**NOTE:**

REFER TO THE CROSS SECTION SHEETS FOR THE LOCATIONS OF THE FURNISHED EXCAVATION AND THE VARIABLE THICKNESS OF THE AGGREGATE SHOULDERS.

FILE NAME =	USER NAME = gelnh	DESIGNED -	REVISED -	<b>STATE OF ILLINOIS DEPARTMENT OF TRANSPORTATION</b>	<b>TYPICAL SECTIONS</b>	F.A.P. RTE.	SECTION	COUNTY	TOTAL SHEETS	SHEET NO.	
ca\p\work\WIDOT\GELINH\08146285\d8768	8-sht-plan.dgn	DRAWN -	REVISED -			592	121-IRS-2	ST CLAIR	13	4	
	PLOT SCALE = 50.0000' / IN.	CHECKED -	REVISED -			CONTRACT NO. 76D18					
	PLOT DATE = 6/21/2010	DATE -	REVISED -			FED. ROAD DIST. NO. - ILLINOIS FED. AID PROJECT					
					SCALE: _____		SHEET NO. 1 OF 1 SHEETS		STA. _____ TO STA. _____		