

WATER MAIN HANGER LAYOUT - ELEVATION OF WEST FACE

Coordinate layout with existing water main to be re-used.

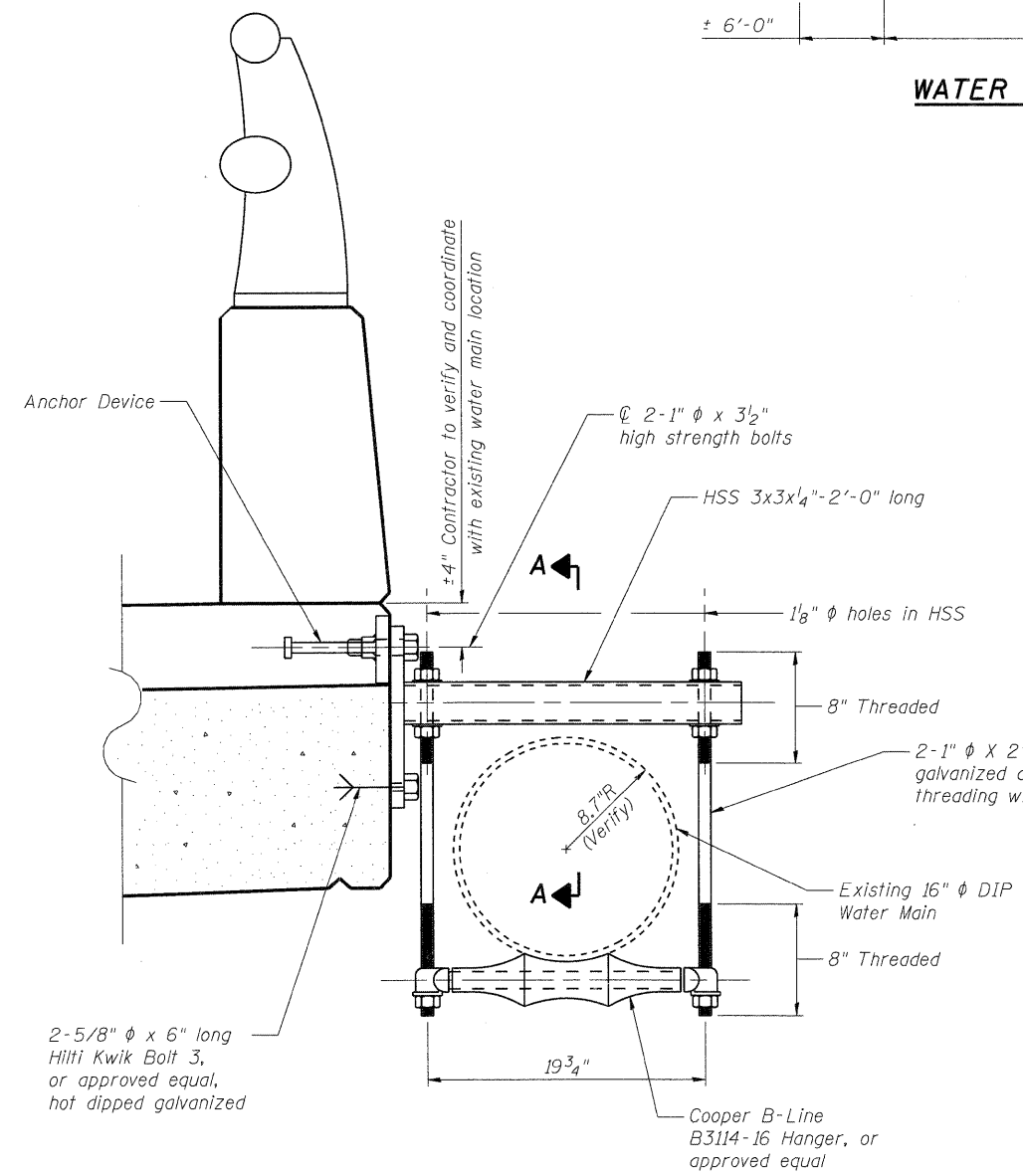

WATER MAIN HANGER DETAIL

(8 Assemblies req'd)

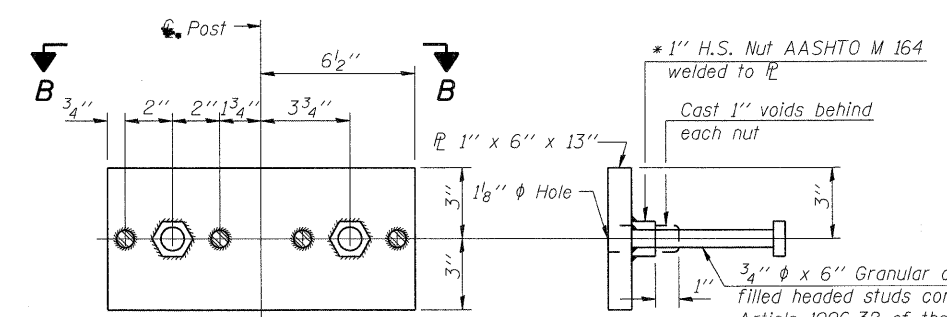

ANCHOR DEVICE

* Threaded areas shall be plugged or blocked off during casting of beam.

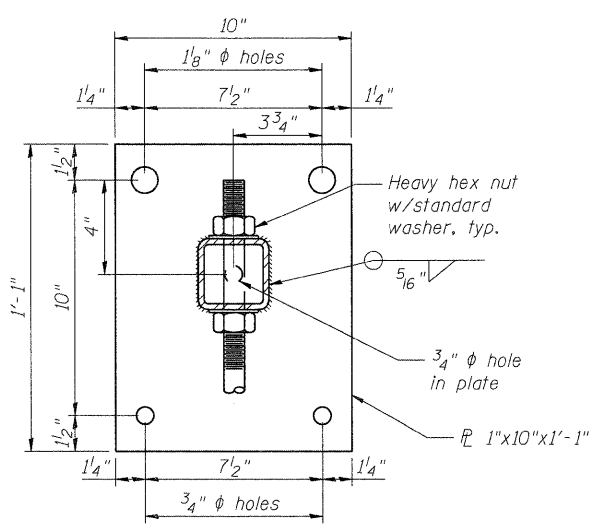

VIEW A-A

Water Main not shown for clarity

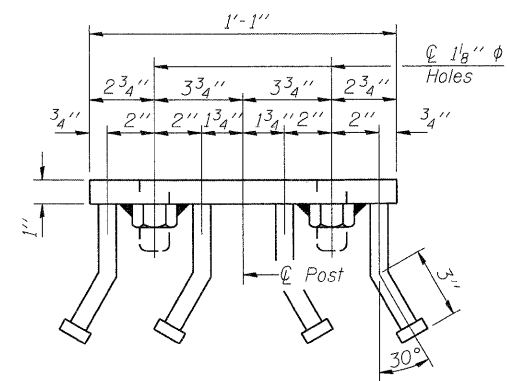

VIEW B-B

NOTES

1. Hollow structural steel tubing shall conform to the requirements of ASTM designation A500 Grade B Structural Steel Tubing and shall meet the longitudinal CVN requirements of 15 ft.-lbs. at 0° F.
2. All other steel shapes and plates shall conform to the requirements of AASHTO M 270 Grade 36.
3. Bolts and nuts shall conform to the requirements of ASTM designation A307 except for high strength bolts, nuts and washers noted which shall conform to AASHTO M 164.
4. All bolts, nuts, washers and lock washers shall be galvanized according to AASHTO M 232.
5. All anchor devices plates and HSS shall be galvanized after shop fabrication according to AASHTO M-111 and ASTM A 385.
6. The 1" φ high strength bolts connecting the plate to the concrete shall be tightend to a snug fit and given an additional 1/8 turn.

SUPERSTRUCTURE DETAILS
CENTRAL AVENUE (FAU ROUTE 5102)
OVER KENT CREEK
SECTION NO. 09-00557-00-BR
CITY OF ROCKFORD
WINNEBAGO COUNTY
STRUCTURE NO. 101-6124

DATE: 1/26/10

| | |
|----------|-----|
| DESIGNED | KMA |
| CHECKED | RGD |
| DRAWN | WJH |
| CHECKED | RGD |

FILE NAME: 090026-sup03.dgn
 PLOT DRIVER: pdf.plt
 PEN TABLE: standard-trans.tbl 1/26/2010

SEC GROUP, INC.
 An HR Green Company
 420 N. Front Street, McHenry, IL 60050
 t. 815.385.1778 f. 815.385.1781
 www.secgroupinc.com
 • McHenry, IL • Yorkville, IL • New Lenox, IL • Chicago, IL

| | | | | | |
|-----------------------|-------------|--------------------|------------------|----------------|-----------|
| SHEET NO. S-6 | F.A.U. RTE. | SECTION | COUNTY | TOTAL SHEETS | SHEET NO. |
| | 5102 | 09-00557-00-BR | WINNEAGO | 18 | 13 |
| S-9 SHEETS | | CONTRACT NO. 85508 | | | |
| FED. ROAD DIST. NO. 2 | | ILLINOIS | FED. AID PROJECT | BHM 5099 (081) | |