

STEEL PILE TABLE

Designation	Depth d	Flange width br	Web and Flange thickness t	Encasement diameter A
HP 14x117	14 1/4"	14 7/8"	13/16"	30"
x102	14"	14 3/4"	1/16"	30"
x89	13 7/8"	14 3/4"	5/8"	30"
x73	13 5/8"	14 5/8"	1/2"	30"
HP 12x84	12 1/4"	12 1/4"	1/16"	24"
x74	12 1/8"	12 1/4"	5/8"	24"
x63	12"	12 1/8"	1/2"	24"
x53	11 3/4"	12"	7/16"	24"
HP 10x57	10"	10 1/4"	9/16"	24"
x42	9 3/4"	10 1/8"	7/16"	24"
HP 8x36	8"	8 1/8"	7/16"	18"

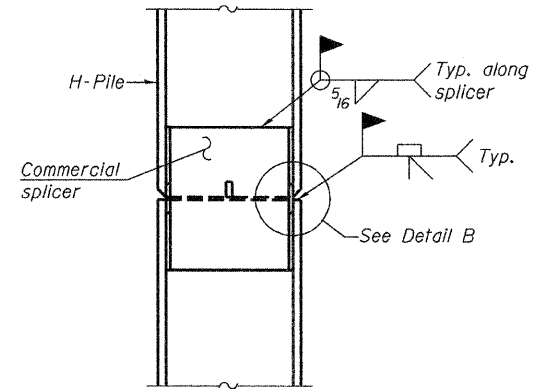

ELEVATION

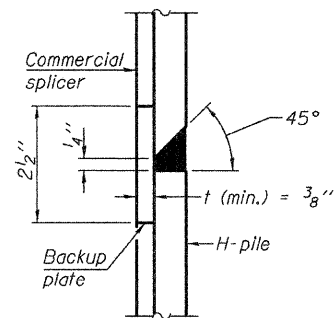

DETAIL "B"

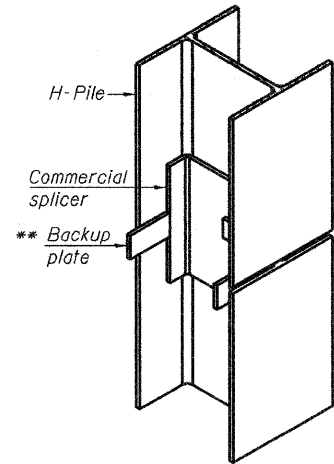

ISOMETRIC VIEW

WELDED COMMERCIAL SPLICE

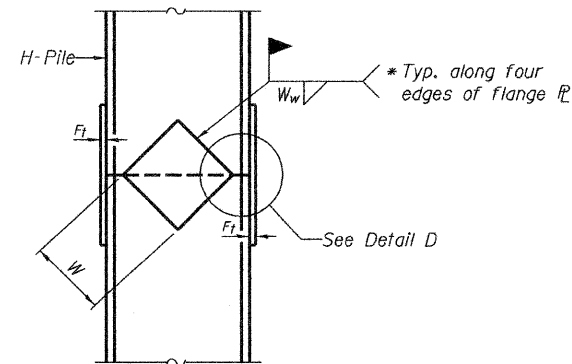

ELEVATION

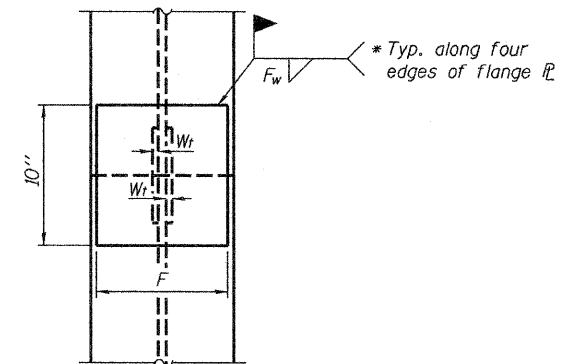

END VIEW

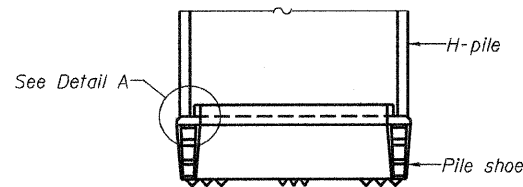

ELEVATION

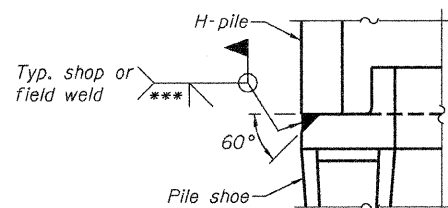

DETAIL A

H-PILE SHOE ATTACHMENT

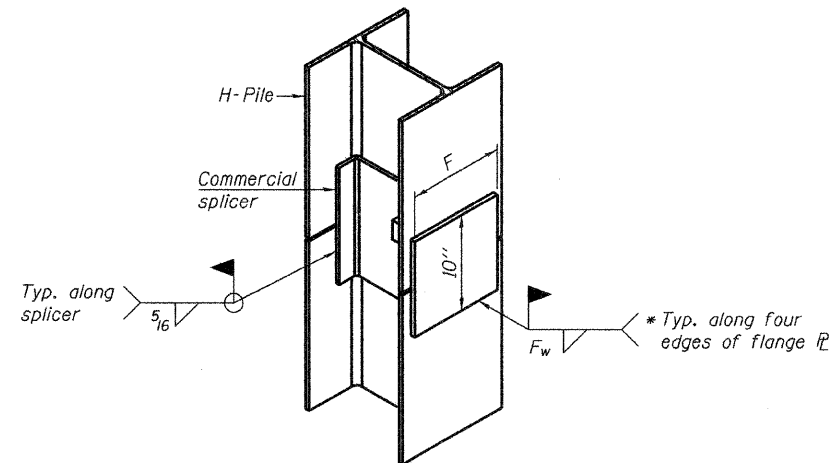

ISOMETRIC VIEW

WELDED COMMERCIAL SPLICE ALTERNATE

- * Interrupt welds 1/4" from end of web and/or each flange.
- ** Remove portions of backup plates that extend outside the flanges.
- *** Weld size per pile shoe manufacturer (5/16" min.).

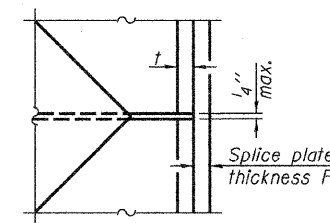

DETAIL D

WELDED PLATE FIELD SPLICE

Designation	F	Ft	Fw	W	Wt	Ww
HP 14x117	12 1/2"	1"	7/8"	7 3/4"	5 1/2"	1/2"
x102	12 1/2"	7/8"	3/4"	7 3/4"	5 1/2"	1/2"
x89	12 1/2"	3/4"	1/16"	7 3/4"	5 1/2"	1/2"
x73	12 1/2"	5/8"	9/16"	7 3/4"	5 1/2"	1/2"
HP 12x84	10"	7/8"	1/16"	6 1/2"	5 1/2"	1/2"
x74	10"	7/8"	1/16"	6 1/2"	5 1/2"	1/2"
x63	10"	5/8"	1/2"	6 1/2"	1/2"	3/8"
x53	10"	5/8"	1/2"	6 1/2"	1/2"	3/8"
HP 10x57	8"	3/4"	9/16"	5 1/4"	1/2"	3/8"
x42	8"	5/8"	9/16"	5 1/4"	1/2"	3/8"
HP 8x36	7"	5/8"	7/16"	4 1/4"	1/2"	3/8"

HP PILE DETAILS
TR 413 OVER FREEDWELL BRANCH
 DATE: 02-05-10 DRAWN BY: JEH CHECKED BY: DF

Note:
 The steel H-piles shall be according to AASHTO M270 Grade 50.

SHEET NO. 6 OF 7 SHEETS	F.A. RTE.	SECTION	COUNTY	TOTAL SHEETS	SHEET NO.
	-	08-09121-00-BR	VERMILION	14	9
		SN 092-3514	CONTRACT NO. 91431		
		FED. ROAD DIST. NO. -	ILLINOIS	FED. AID PROJECT	

ESI ESI CONSULTANTS, LTD
 750 WINDSOR ROAD
 CHARLESTON, IL 61920
 (317) 548-1500
 WWW.ESICONSULTANTS.LTD.COM
 ILLINOIS DEPARTMENT OF PROFESSIONAL REGULATION REGISTRATION #184-003889

F-HP 11-1-09

PRINTED DATE: 2/23/2010
 FILE NAME: M:\Projects\Vermillion\County of ITR 413 over Freedwell Branch\CADD\Drawings\Sheets\99_Freedwell_PILE_DET.dgn