

**OPTION 1**

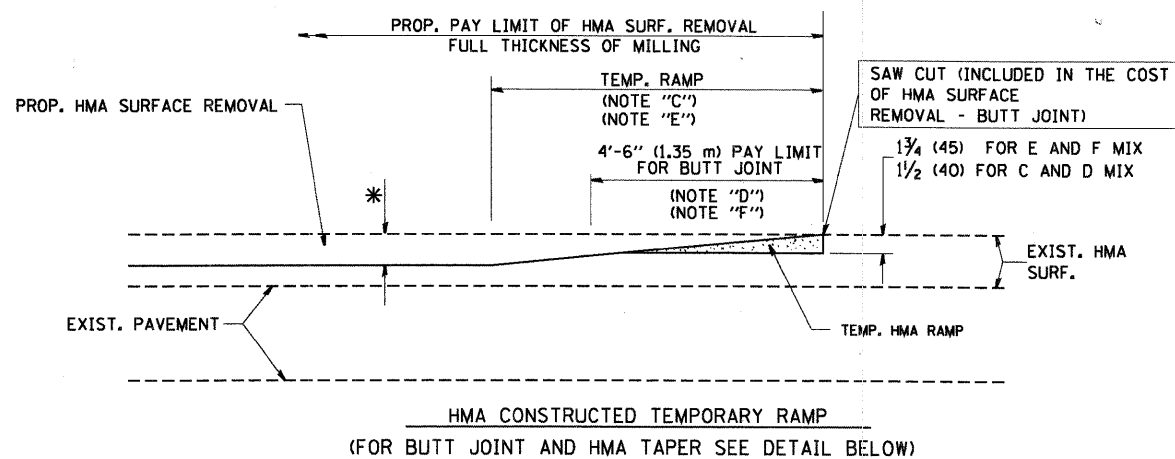

**OPTION 2**

**TYPICAL TEMPORARY RAMP**

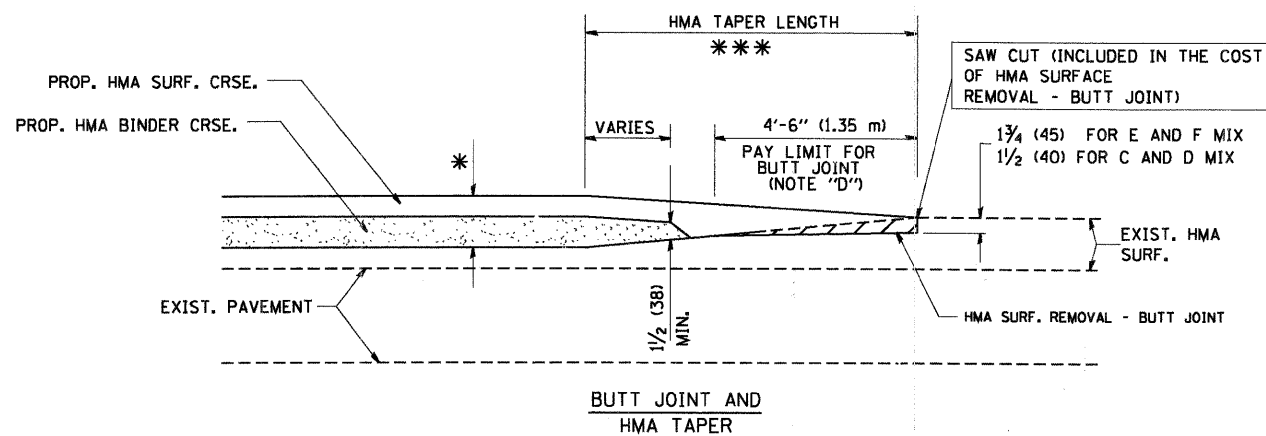

**TYPICAL BUTT JOINT AND HMA TAPER FOR MILLING AND RESURFACING**

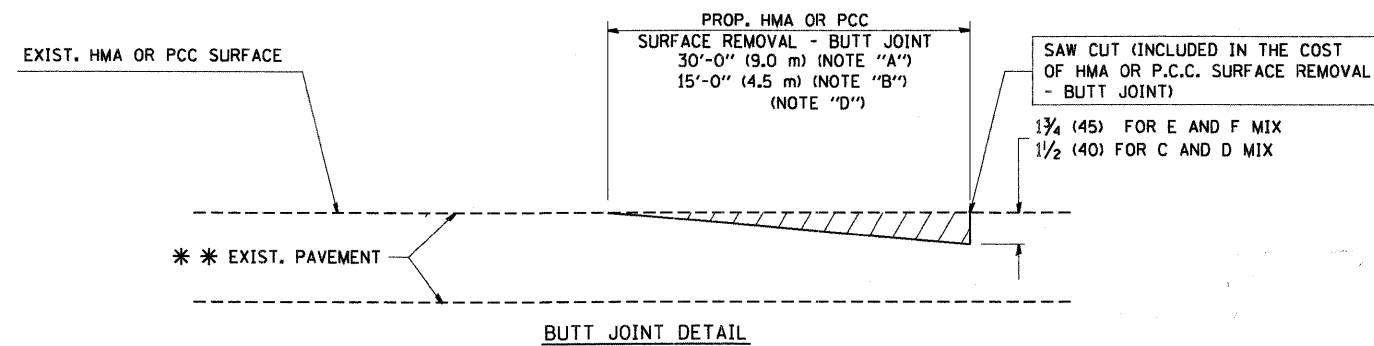

**BUTT JOINT DETAIL**

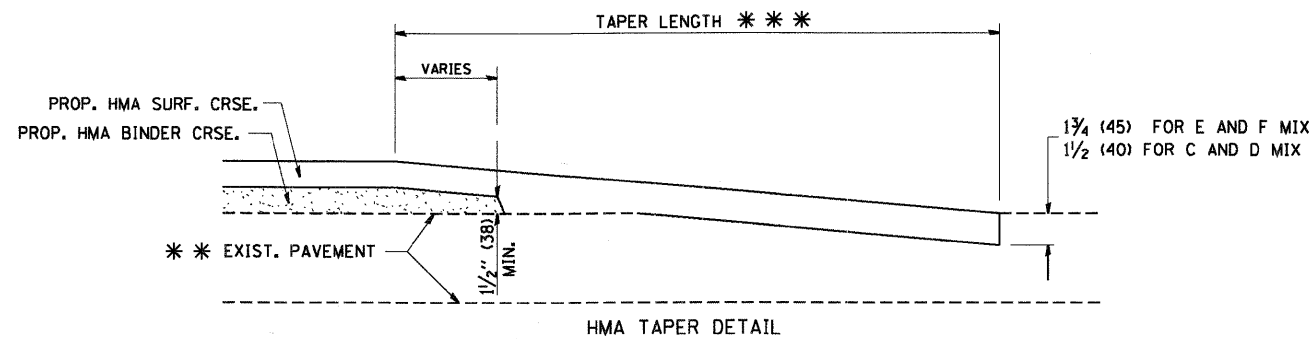

**HMA TAPER DETAIL**

**TYPICAL BUTT JOINT AND HMA TAPER FOR RESURFACING ONLY**

\*\*\* PC CONCRETE, HMA OR HMA RESURFACED PAVEMENT.

**NOTES**

- A: MAINLINE ROADWAYS AND MAJOR SIDE ROADS.
  - B: MINOR SIDE ROADS.
  - C: THE TEMP. RAMP SHALL BE CONSTRUCTED IMMEDIATELY UPON REMOVAL OF THE EXISTING HMA SURFACE.
  - D: THE BUTT JOINT SHALL BE CONSTRUCTED IMMEDIATELY PRIOR TO PLACING THE PROPOSED HMA COURSES.
  - E: TAPER THE TEMP. RAMP AT A RATE OF 3'-0" (900 mm) PER 1 INCH (25 mm) OF MILLING THICKNESS.
  - F: INSTALLATION AND REMOVAL OF THE 4'-6" (1.35 m) TEMP. RAMP IS INCLUDED IN COST OF HMA SURFACE REMOVAL - BUTT JOINT
  - G: SEE ARTICLE 406.08 AND 406.14 OF THE STANDARD SPECIFICATIONS FOR "HMA AND/OR PCC SURFACE REMOVAL, BUTT JOINT".
- \* SEE TYPICAL SECTIONS FOR MILLING THICKNESS.
- \*\*\* 20'-0" (6.1 m) PER 1 (25) RESURFACING (NOTE "A")  
 10'-0" (3.0 m) PER 1 (25) RESURFACING (NOTE "B")

**BASIS OF PAYMENT:**

THE BUTT JOINT WILL BE PAID FOR AT THE CONTRACT UNIT PRICE PER SQUARE YARD (SQUARE METER) FOR "HOT-MIX ASPHALT SURFACE REMOVAL - BUTT JOINT" OR FOR "PORTLAND CEMENT CONCRETE SURFACE REMOVAL - BUTT JOINT".

ALL DIMENSIONS ARE IN INCHES (MILLIMETERS) UNLESS OTHERWISE SHOWN.

COMPANY NAME: Smith  
 PROJECT CONTACT: A. CHAUDHRY  
 CLIENT: VILLAGE OF STREAMWOOD  
 DATE PLOTTED: 5/26/2009 11:56:38 AM  
 FILE NAME: 090118-det-04.dgn  
 PLOT DRIVER: pdfplot  
 PEN TABLE: standard-trans.tbl



USER NAME = charlke	DESIGNED - M. DE YONG	REVISED - R. SHAH 10-25-94
	DRAWN -	REVISED - A. ABBAS 03-21-97
PLOT SCALE =	CHECKED -	REVISED - M. GOMEZ 04-06-01
PLOT DATE = 5/26/2009	DATE - 06-23-09	REVISED - R. BORO 01-01-07

**VILLAGE OF STREAMWOOD**

**BUTT JOINT AND HMA TAPER DETAILS**

SCALE: SHEET NO. OF SHEETS STA. TO STA.

F.A.U. RTE.	SECTION	COUNTY	TOTAL SHEETS	SHEET NO.
1321	09-00053-00-R5	COOK	13	8
BD400-05 BD32		CONTRACT NO. 63213		
FED. ROAD DIST. NO.		ILLINOIS FED. AID PROJECT ARA-9003(304)		