

FAU RTE	SECTION	COUNTY	TOTAL SHEETS	SHEET NO.
VARIOUS	06-00080-00-BT	COOK	16	15
F.H.W.A. REG.	ILLINOIS	PROJECT	HPP-3463(004)	

CONTRACT NO. 63220

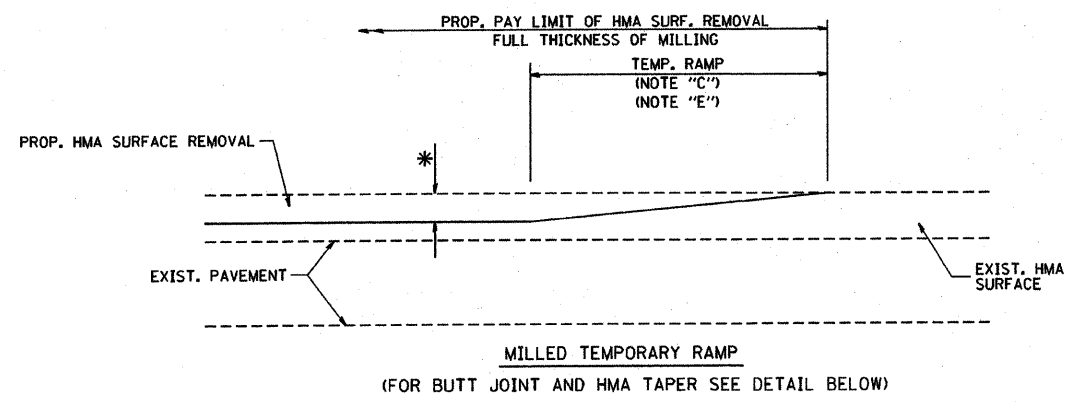

**OPTION 1**

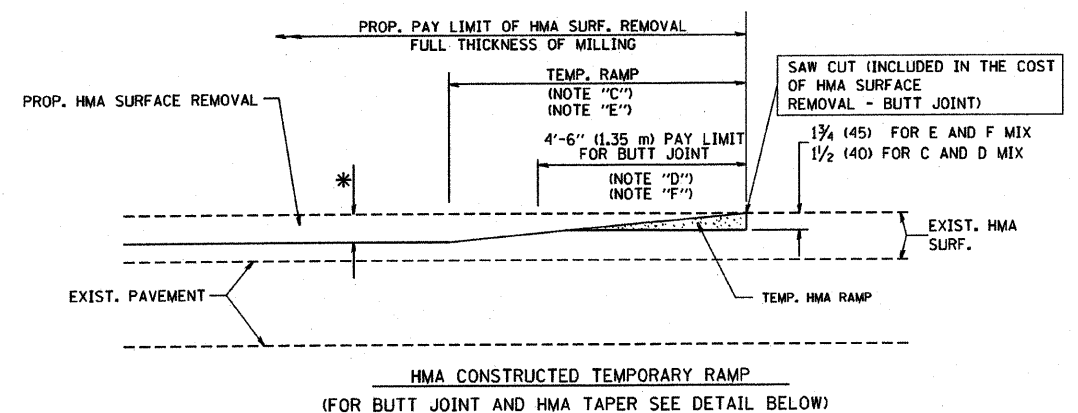

**OPTION 2**  
**TYPICAL TEMPORARY RAMP**

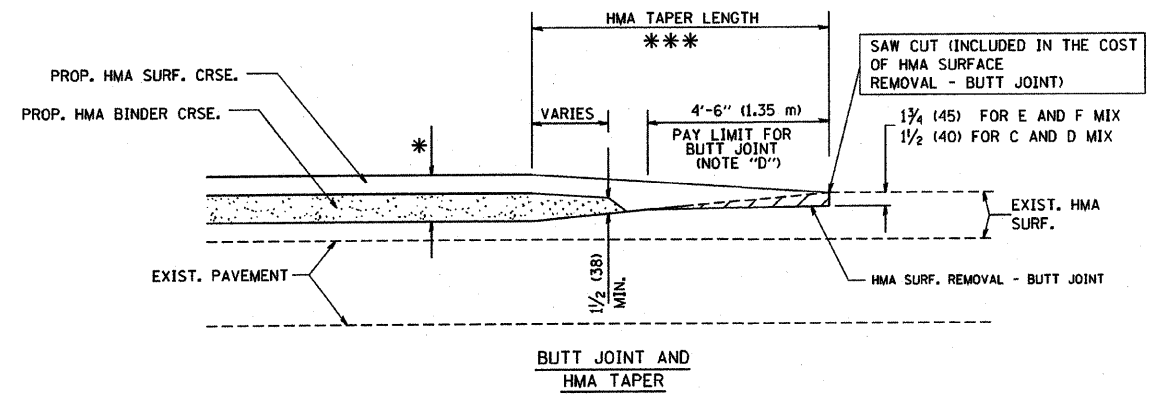

**TYPICAL BUTT JOINT AND HMA TAPER FOR MILLING AND RESURFACING**

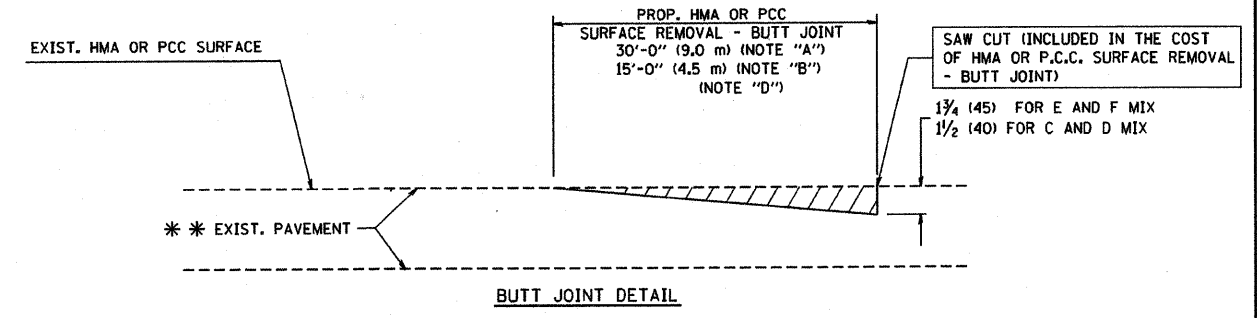

**BUTT JOINT DETAIL**

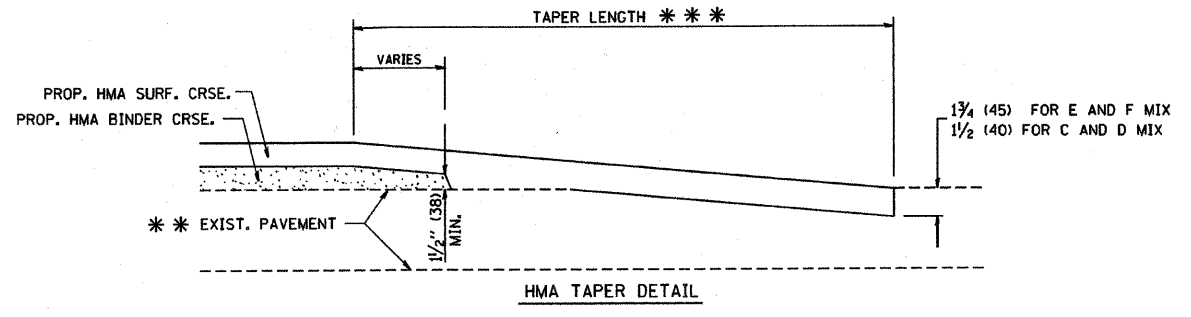

**TYPICAL BUTT JOINT AND HMA TAPER FOR RESURFACING ONLY**

\*\* PC CONCRETE, HMA OR HMA RESURFACED PAVEMENT.

**NOTES**

- A: MAINLINE ROADWAYS AND MAJOR SIDE ROADS.
- B: MINOR SIDE ROADS.
- C: THE TEMP. RAMP SHALL BE CONSTRUCTED IMMEDIATELY UPON REMOVAL OF THE EXISTING HMA SURFACE.
- D: THE BUTT JOINT SHALL BE CONSTRUCTED IMMEDIATELY PRIOR TO PLACING THE PROPOSED HMA COURSES.
- E: TAPER THE TEMP. RAMP AT A RATE OF 3'-0" (900 mm) PER 1 INCH (25 mm) OF MILLING THICKNESS.
- F: INSTALLATION AND REMOVAL OF THE 4'-6" (1.35 m) TEMP. RAMP IS INCLUDED IN COST OF HMA SURFACE REMOVAL - BUTT JOINT
- G: SEE ARTICLE 406.08 AND 406.14 OF THE STANDARD SPECIFICATIONS FOR 'HMA AND/OR PCC SURFACE REMOVAL, BUTT JOINT'.
- \* SEE TYPICAL SECTIONS FOR MILLING THICKNESS.
- \*\* 20'-0" (6.1 m) PER 1 (25) RESURFACING (NOTE "A")
- \*\*\* 10'-0" (3.0 m) PER 1 (25) RESURFACING (NOTE "B")

ALL DIMENSIONS ARE IN INCHES (MILLIMETERS) UNLESS OTHERWISE SHOWN.

**BASIS OF PAYMENT:**

THE BUTT JOINT WILL BE PAID FOR AT THE CONTRACT UNIT PRICE PER SQUARE YARD (SQUARE METER) FOR "HOT-MIX ASPHALT SURFACE REMOVAL - BUTT JOINT" OR FOR "PORTLAND CEMENT CONCRETE SURFACE REMOVAL - BUTT JOINT".

REVISIONS	
NO.	DATE
M. DE YONG	6-13-90
M. DE YONG	7-3-90
M. DE YONG	3-27-92
R. SHAH	09/09/94
R. SHAH	10/25/94
A. ABBAS	03/21/97
M. COMEZ	04/06/01
R. BORO	01/01/07

ILLINOIS DEPARTMENT OF TRANSPORTATION

**BUTT JOINT AND HMA TAPER DETAILS**

SCALE: VERT. NONE  
HORIZ. NONE  
DRAWN BY  
CHECKED BY  
BD400-05 (V1=BD32)

PLOT DATE: 3/5/2007  
FILE NAME: K:\david\0603.dgn  
PLOT SCALE: 50:1  
USER: david

**Frank Novotny & Associates, Inc.**  
Civil Engineers/Municipal Consultants  
825 Midway Drive ♦ Willowbrook, IL ♦ 60527 ♦ Telephone: (630) 887-8640 ♦ Fax: (630) 887-0132  
Illinois Professional Design Firm No. 184-000928

PROJECT **VILLAGE OF NORTH RIVERSIDE, ILLINOIS**  
**VILLAGE WIDE BIKE PATH - STAGE 1**  
**26TH STREET RESURFACING (1ST AVENUE TO DES PLAINES AVENUE)**  
**& VILLAGE COMMONS COMPLEX PARKING REHABILITATION**  
M.F.T. SECTION NO. 06-00080-00-BT

REVISIONS			
NO.	BY	DATE	DESCRIPTION

**BUTT JOINT AND HMA TAPER DETAILS**

PROJECT NO. 03049	SCALE NONE	SHEET 15
DRAWN/DESIGNED JEP/AMS	DATE APRIL, 2009	OF 16
CHECKED/APPROVED JFP/JEF	FIELD BOOK NO. FILE	SHEETS