

0420041\_76B01\_05\_FRMB.DGN AUG. 20, 2008

STATE OF ILLINOIS  
DEPARTMENT OF TRANSPORTATION

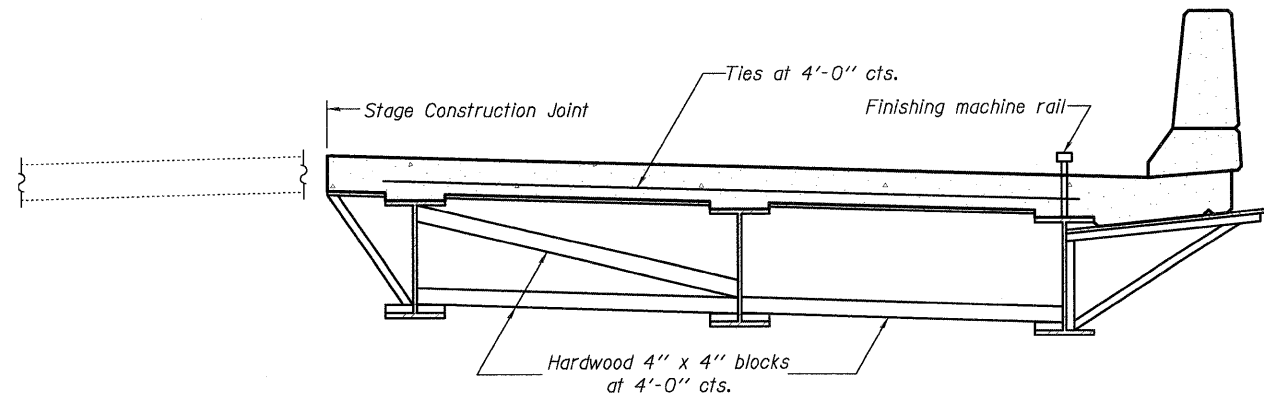

**FORM BRACES FOR STAGE CONSTRUCTION**

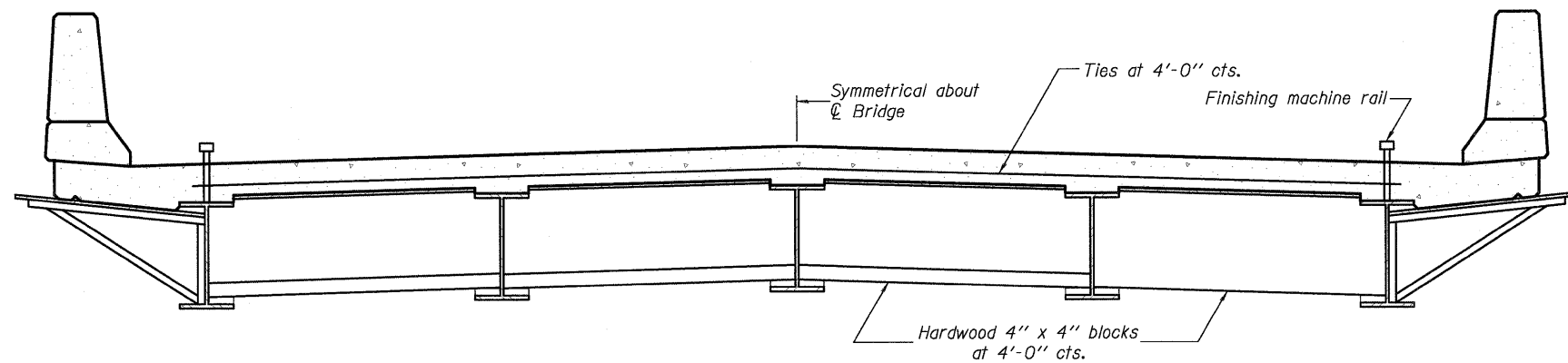

**FORM BRACES FOR STANDARD CONSTRUCTION**

When cantilever forming brackets are used, the work shall be done according to Article 503.06(b) of the Standard Specifications, except as modified below and in the details shown on this sheet.

The finishing machine rails shall be placed on the top flange of the exterior beams.

The beams or girders, supporting cantilever forming brackets, shall be tied together at 4 foot intervals.

For Standard construction, or Stage Construction the Hardwood bracing materials shall be placed as shown between webs of beams in each bay.

DESIGNED	K.M.M.
CHECKED	L.D.G.
DRAWN	K.H.L.
CHECKED	B.G.H.

SB-1 5-16-08

**CANTILEVER FORMING BRACKETS FOR SUPERSTRUCTURES  
WITH W27 BEAMS AND SMALLER**

SHEET NO. 5	F.A.P. RTE.	SECTION	COUNTY	TOTAL SHEETS	SHEET NO.
	325	3BR-2	JERSEY	90	46
21 SHEETS	S.N. 042-0041		CONTRACT NO. 76B01		
FED. ROAD DIST. NO. ILLINOIS FED. AID PROJECT					

H.M. & G. NO. 6020.III