

0420041.76B01.19.PILE.DGN AUG. 20, 2008

STATE OF ILLINOIS
DEPARTMENT OF TRANSPORTATION

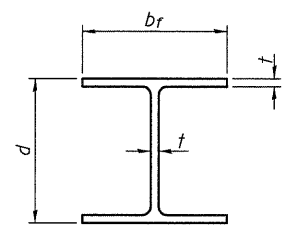

STEEL PILE TABLE

Designation	Depth d	Flange width br	Web and Flange thickness t	Encasement diameter A
HP 14x117	14 1/4"	14 7/8"	13/16"	30"
x102	14"	14 3/4"	1/16"	30"
x89	13 7/8"	14 3/4"	5/8"	30"
x73	13 5/8"	14 5/8"	1/2"	30"
HP 12x84	12 1/4"	12 1/4"	1/16"	24"
x74	12 1/8"	12 1/4"	5/8"	24"
x63	12"	12 1/8"	1/2"	24"
x53	11 3/4"	12"	7/16"	24"
HP 10x57	10"	10 1/4"	9/16"	24"
x42	9 3/4"	10 1/8"	7/16"	24"
HP 8x36	8"	8 1/8"	7/16"	18"

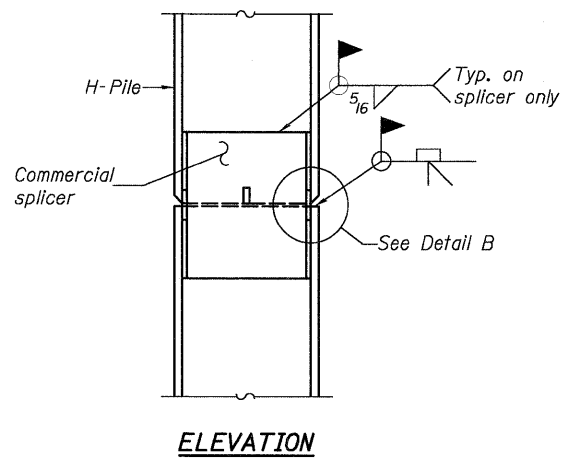

ELEVATION

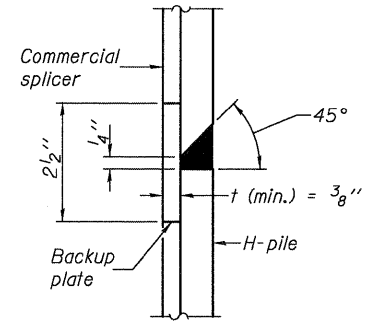

DETAIL "B"

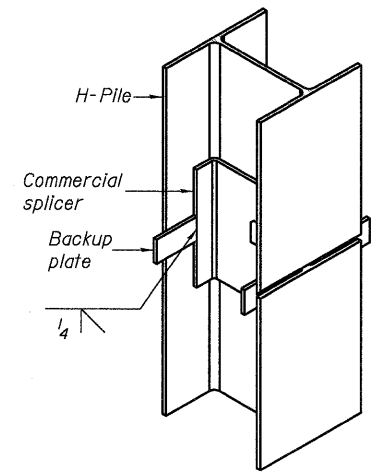

ISOMETRIC VIEW

WELDED COMMERCIAL SPLICE

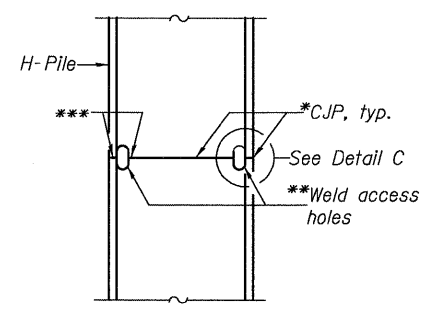

ELEVATION

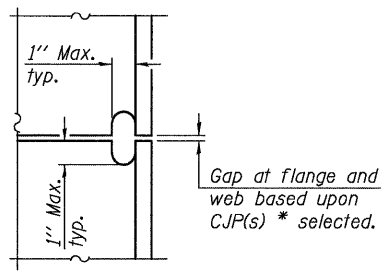

DETAIL C

COMPLETE PENETRATION WELD SPLICE

*Use joint conforming to Figure 3.4 in AWS D1.1, Structure Welding Code-Steel.
 **Preparation per Fig. 5.2 in AWS D1.1, Structure Welding Code-Steel.
 ***Interrupt welds 1/4" from end of each pile.

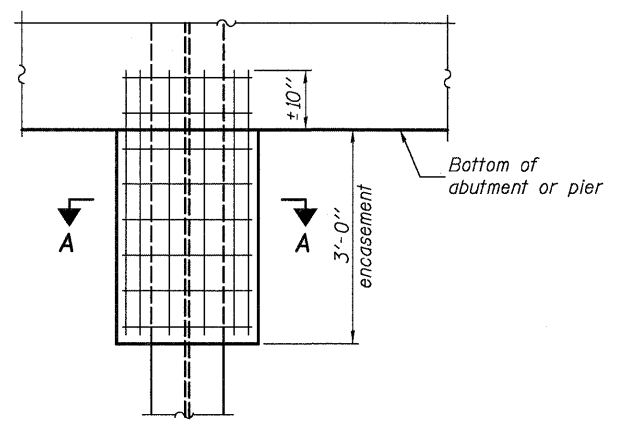

ELEVATION

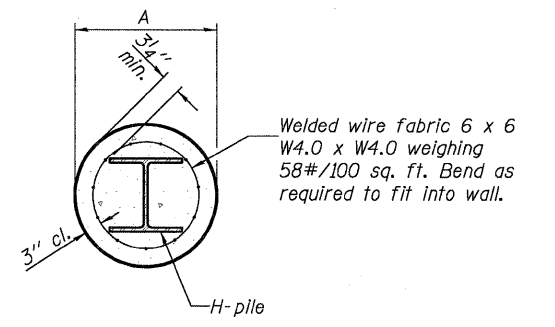

SECTION A-A

PILE ENCASEMENT

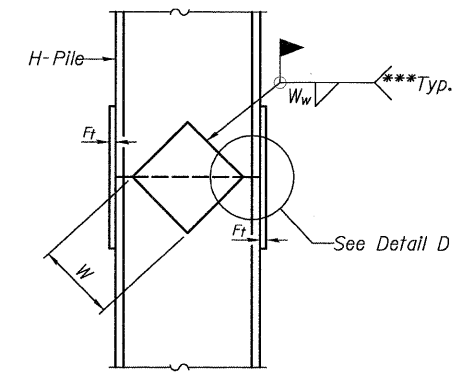

ELEVATION

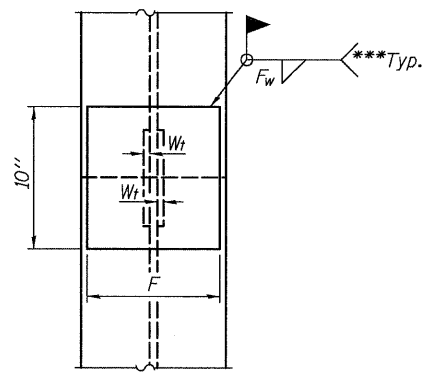

END VIEW

Designation	F	F _t	F _w	W	W _t	W _w
HP 14x117	12 1/2"	1"	7/8"	7 3/4"	5 1/2"	1/2"
x102	12 1/2"	7/8"	3/4"	7 3/4"	5 1/2"	1/2"
x89	12 1/2"	3/4"	1/16"	7 3/4"	5 1/2"	1/2"
x73	12 1/2"	5/8"	9/16"	7 3/4"	5 1/2"	1/2"
HP 12x84	10"	7/8"	1/16"	6 1/2"	5 1/2"	1/2"
x74	10"	7/8"	1/16"	6 1/2"	5 1/2"	1/2"
x63	10"	5/8"	1/2"	6 1/2"	1/2"	3/8"
x53	10"	5/8"	1/2"	6 1/2"	1/2"	3/8"
HP 10x57	8"	3/4"	9/16"	5 1/4"	1/2"	3/8"
x42	8"	5/8"	9/16"	5 1/4"	1/2"	3/8"
HP 8x36	7"	5/8"	7/16"	4 1/4"	1/2"	3/8"

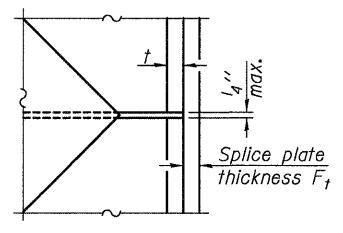

DETAIL D

WELDED PLATE FIELD SPLICE

Note: The steel H-piles shall be according to AASHTO M270 Grade 50.

HP PILE DETAILS

SHEET NO. 19 21 SHEETS	F.A.P. RTE. 325	SECTION 3BR-2	COUNTY JERSEY	TOTAL SHEETS 90	SHEET NO. 60
	S.N. 042-0041		CONTRACT NO. 76B01		
FED. ROAD DIST. NO. ILLINOIS FED. AID PROJECT					

DESIGNED	K.M.M.
CHECKED	L.D.G.
DRAWN	K.H.L.
CHECKED	B.G.H.
F-HP	5-16-08

H.M. & G. NO. 6020.III