

CONSTRUCTION PLANS FOR WILLARD AIRPORT

UNIVERSITY OF ILLINOIS
SAVOY, ILLINOIS

FINAL

IL. PROJ. NO. CMI-4408

AIP PROJ. NO. 3-17-0016-XX

REMARK RUNWAY THRESHOLDS

SHEET LIST TABLE	
SHEET NUMBER	SHEET TITLE
01	COVER SHEET
02	GENERAL NOTES
03	AIRPORT SITE PLAN
04	CONSTRUCTION SAFETY PHASING NOTES
05	CONSTRUCTION ACTIVITY PLAN NOTES & DETAILS
06	CONSTRUCTION ACTIVITY PLAN - PHASE 1
07	CONSTRUCTION ACTIVITY PLAN - PHASE 2
08	REMOVAL AND REPLACEMENT PLAN RUNWAY 14L -32R
09	REMOVAL AND REPLACEMENT PLAN RUNWAY 4-22
10	PAVEMENT MARKING DETAILS
11	PAVEMENT GROOVING CLEANING MARKING DETAILS

SUMMARY OF QUANTITIES			
ITEM NO.	DESCRIPTION	UNIT	QUANTITY
AR501545	CLEAN PCC PAVEMENT GROOVING	LF	1,900
AR620520	PAVEMENT MARKING - WATERBORNE	SF	41,400
AR620525	PAVEMENT MARKING - BLACK BORDER	SF	15,048
AR620900	PAVEMENT MARKING REMOVAL	SF	79,040

APRIL 17, 2015

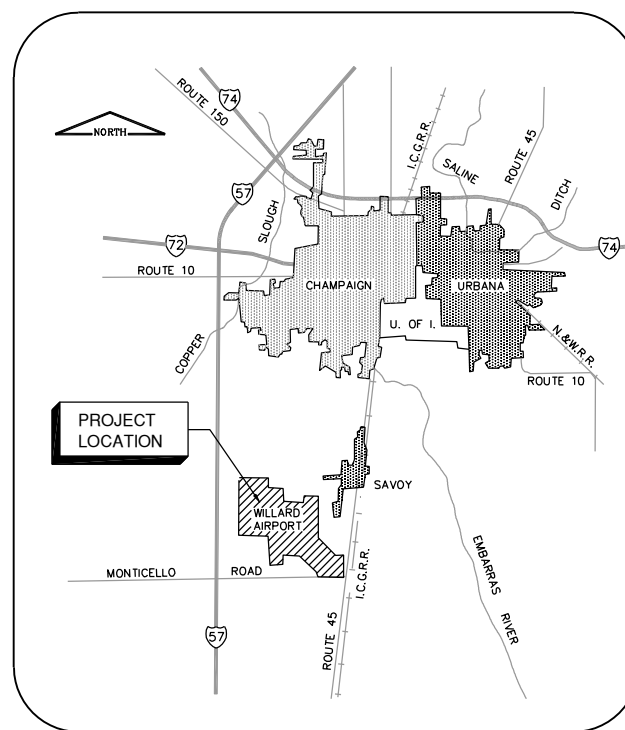

LOCATION MAP

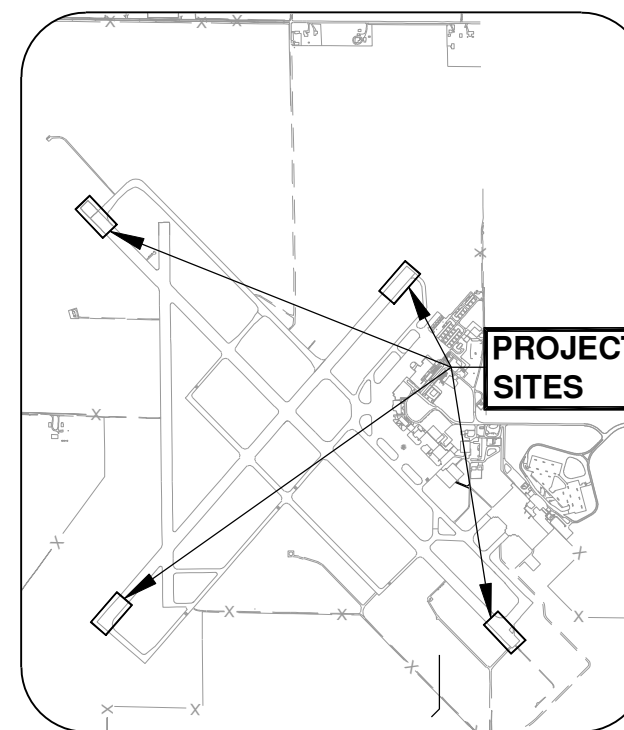

SITE PLAN

Exp. 11-30-2015

 Christopher B. Groth
 4-21-2015

GROUND CONTROL RADIO FREQUENCY - 121.8
 ATIS FREQUENCY - 124.85
 APPROXIMATE MAXIMUM HEIGHT OF EQUIPMENT
 ABOVE GROUND IS 25 FT.

UNIVERSITY OF ILLINOIS
 WILLARD AIRPORT
 APPROVED:
 DATE: 4/14/2015 2015

License No. 184-000613
 SUBMITTED BY:
 DATE: 4-21-2015
 CMT JOB NUMBER: 14059-03

K:\Champaign\1405903\Draw\Sheets
 FILE: CMI4408-1405903-GC000.dwg
 UPDATE BY: Chris Groth
 PLOT DATE: 6/29/2015 10:57 AM

CALL J.U.I.E.
 BEFORE EXCAVATING
 1-800-892-0123
 TOWNSHIP: T 18 N
 RANGE: R 8 E
 SECTION: 2, 3, 10 AND 11
 COUNTY: CHAMPAIGN
 CIVIL TOWNSHIP: TOLONO

GENERAL NOTES

1. ALL RUNWAYS, TAXIWAYS AND APRONS SHALL BE KEPT OPEN TO AIRCRAFT TRAFFIC DURING CONSTRUCTION EXCEPT AS NOTED IN THE CONSTRUCTION ACTIVITY PLANS OR AS DIRECTED BY THE AIRPORT MANAGER.
2. ALL CONSTRUCTION TRAFFIC OPERATING ON OR CROSSING ACTIVE RUNWAYS, TAXIWAYS AND APRONS SHALL BE UNDER CONTROL OF A FLAGMAN IN RADIO CONTACT WITH FAA AIR TRAFFIC CONTROL TOWER PERSONNEL AT ALL TIMES. THE CONTRACTOR SHALL PROVIDE HIS OWN RADIOS.
3. WHEN CONFLICTS ARISE BETWEEN CONSTRUCTION ACTIVITIES AND AIRCRAFT OPERATIONS AND SAFETY, AIRCRAFT OPERATIONS AND SAFETY SHALL TAKE PRECEDENCE AND SHALL GOVERN. FINAL AUTHORITY IN THE APPROVAL OF CLOSING AND OPENING PAVEMENTS AND CONSTRUCTION SEQUENCING LIES WITH THE AIRPORT MANAGER.
4. THE CONTRACTOR SHALL STORE EQUIPMENT AND MATERIALS AT THE LOCATION SHOWN FOR THE "CONTRACTOR'S STAGING, STORAGE, PARKING SITE AND FIELD OFFICE".
5. BROKEN OR WASTE CONCRETE AND ASPHALT SHALL BE DISPOSED OF BY THE CONTRACTOR OFF AIRPORT PROPERTY, UNLESS DIRECTED BY THE AIRPORT MANAGER.
6. VEHICLES AND EQUIPMENT SHALL NOT BE ALLOWED WITHIN AREAS 130' (ADG IV - OFA) FROM THE CENTERLINE OF ACTIVE TAXIWAYS OR 250' FROM THE CENTERLINE OF ACTIVE RUNWAYS.
7. ALL PAVEMENTS, DRIVES AND OTHER AREAS USED BY THE CONTRACTOR FOR HAUL ROADS AND STORAGE AREAS SHALL BE MAINTAINED AND REPAIRED IN KIND BY THE CONTRACTOR TO THE SATISFACTION OF AIRPORT MANAGER. NO ADDITIONAL COMPENSATION SHALL BE MADE TO THE CONTRACTOR FOR THIS WORK.
8. EXISTING TURF & AGRICULTURAL AREAS DISTURBED BY THE CONTRACTOR'S OPERATIONS OUTSIDE OF THE TURFING LIMITS SHALL BE COMPLETELY RESTORED BY HIM AT HIS EXPENSE TO THE SATISFACTION OF THE AIRPORT MANAGER.
9. THE CONTRACTOR SHALL THOROUGHLY CLEAN ALL CONSTRUCTION AREAS PRIOR TO OPENING TO AIR TRAFFIC.
10. REFER TO THE CONSTRUCTION ACTIVITY PLANS AND THE SPECIFICATIONS FOR ADDITIONAL REQUIREMENTS CONCERNING COORDINATION OF CONSTRUCTION ACTIVITIES.
11. THE ARFF VEHICLES SHALL HAVE COMPLETE ACCESS TO THE ENTIRE AIRFIELD INCLUDING THE CLOSURE AREAS.
12. THE CONTRACTOR IS REQUIRED TO GIVE TEN (10) FULL WORKING DAYS NOTICE TO THE AIRPORT MANAGER PRIOR TO CLOSING WORK AREAS TO AIRCRAFT.
13. AT THE PRECONSTRUCTION MEETING, CONTRACTOR SHALL SUPPLY THE AIRPORT MANAGER WITH PROPOSED CLOSURE AND PHASING DATES FOR HIS REVIEW AND APPROVAL. THE RESIDENT ENGINEER SHALL KEEP THE AIRPORT MANAGER ADVISED OF ANY PROPOSED CHANGES IN CLOSURE AND PHASING DATES.
14. ALL CONTRACTOR'S VEHICLES AND EQUIPMENT SHALL DISPLAY AN ORANGE AND WHITE CHECKED AVIATION SIGNAL FLAG, EXCEPT HAUL VEHICLES.
15. ANY VEHICLE OPERATING WITHIN A MOVEMENT AREA DURING THE HOURS OF DARKNESS SHOULD BE EQUIPPED WITH AN AMBER REVOLVING OR FLASHING DOME-TYPE LIGHT AS SPECIFIED IN THE SPECIAL PROVISIONS.
16. IF, DURING CONSTRUCTION, AN EMERGENCY IS DECLARED BY THE AIRPORT, THE CONTRACTOR SHALL IMMEDIATELY CLEAR THE PAVEMENT OF ALL VEHICLES, PERSONNEL AND EQUIPMENT.

CONTRACTOR'S ACCESS

1. CONTRACTOR'S ACCESS SHALL BE AS FOLLOWS:
 - A. THE CONTRACTORS ACCESS TO THE WORK SHALL BE AS SHOWN ON THE SITE PLAN AND CONSTRUCTION ACTIVITY PLANS.
 - B. DURING ADVERSE WEATHER, THE CONTRACTOR SHALL MAKE PROVISIONS FOR ACCESS TO THE WORK SITE AT NO ADDITIONAL COST TO THE CONTRACT. NO EXTENSION OF CONTRACT TIME WILL BE CONSIDERED FOR DELAYS DUE TO LACK OF ADEQUATE ACCESS TO THE WORK.
 - C. THE CONTRACTOR SHALL INSTALL AND MAINTAIN A HEAVY-DUTY PADLOCK ON THE ACCESS GATE. HE SHALL PROVIDE KEYS FOR THIS PADLOCK TO THE RESIDENT ENGINEER, AIRPORT SECURITY AND MAINTENANCE SUPERVISOR. NO ADDITIONAL KEYS ARE TO BE DISTRIBUTED UNLESS AUTHORIZED BY THE AIRPORT MANAGER.
 - D. THE CONTRACTOR SHALL BE RESPONSIBLE FOR KEEPING ALL CONSTRUCTION ACCESS GATES CLOSED & SECURED AT ALL TIMES INCLUDING WORK HOURS. IF THE CONTRACTOR CHOOSES TO LEAVE THE GATE OPEN, HE SHALL POST A COMPETENT, **FULL TIME SECURITY GUARD TO PREVENT UNAUTHORIZED ENTRIES**. THE CONTRACTOR SHALL REPLACE ANY UNSATISFACTORY SECURITY GUARDS IF SO DIRECTED BY THE AIRPORT MANAGER OR ENGINEER.
 - E. THE CONTRACTOR SHALL CLOSE AND LOCK THE ACCESS GATES UPON LEAVING THE SITE.
 - F. THROUGHOUT THE DURATION OF THE CONTRACT, ANY DAMAGE TO THE ACCESS GATES OR FENCING ADJACENT TO THE PROJECT SHALL BE REPAIRED BY THE CONTRACTOR TO THE SATISFACTION OF THE AIRPORT MANAGER.
 - G. ALL COSTS RELATING TO CONTRACTOR'S ACCESS AND SECURITY SHALL BE THE RESPONSIBILITY OF THE CONTRACTOR.
 - H. THE CONTRACTOR SHALL STORE EQUIPMENT AND MATERIALS IN SUCH A WAY AS TO NOT DISTURB AGRICULTURAL AREAS OR VIOLATE THE PART 77 APPROACH AND PRIMARY SURFACES.
 - I. EMPLOYEE PERSONAL VEHICLES SHALL NOT BE ALLOWED BEYOND THE CONTRACTOR'S PARKING AREA. CONTRACTOR PERSONNEL SHALL PARK IN THE CONTRACTOR'S STORAGE AREA. PERSONNEL SHALL BE TRANSPORTED TO THE WORK SITE BY COMPANY OWNED VEHICLES.
 - J. THE CONTRACTOR SHALL BE RESPONSIBLE FOR COORDINATING ALL ACCESS ROADS WITH THE APPROPRIATE AGENCY RESPONSIBLE FOR THE ROADWAY.
 - K. THE CONTRACTOR SHALL HAVE A VACUUM TYPE SWEEPER AVAILABLE AT ALL TIMES.
2. AN AREA WILL BE PROVIDED BY THE AIRPORT TO THE CONTRACTOR AS THE STAGING, STORAGE AND EMPLOYEE PARKING SITE, AT THE LOCATION SHOWN.
3. A LIST OF AUTHORIZED PERSONNEL PERMITTED TO USE THE GATE SHALL BE PROVIDED BY THE CONTRACTOR TO THE RESIDENT ENGINEER.
4. THE CONTRACTOR SHALL PROVIDE A SIGN AT THE ACCESS GATE SAYING "AUTHORIZED PERSONNEL & CONSTRUCTION ACCESS ONLY".
5. SUPERINTENDENT, SUPERVISING FOREMEN, ESCORT PERSONNEL AND SECURITY GUARDS ON THE AIRFIELD WILL BE REQUIRED TO SUBMIT A TEN YEAR BACKGROUND CHECK TO AIRPORT SECURITY AND WILL BE REQUIRED TO BE TRAINED BY THE AIRPORT TO GAIN ACCESS PER SECTION 80-13 OF THE SPECIFICATIONS. CONTRACTOR SHALL COORDINATE THE BADGING PROCESS A MINIMUM OF 10 DAYS PRIOR TO REQUESTING ACCESS TO THE FIELD.

UN054

REVISIONS

NUMBER	BY	DATE

0 1 2
 THIS BAR IS EQUAL TO 2"
 AT FULL SCALE (34x22).

UNIVERSITY OF ILLINOIS
 WILLARD AIRPORT
 SAVOY, ILLINOIS

REMARK RUNWAY THRESHOLDS

GENERAL NOTES

CONTRACTOR'S RESPONSIBILITY FOR UTILITY SERVICE

THE LOCATION OF UNDERGROUND UTILITIES AS INDICATED ON THE PLANS HAS BEEN OBTAINED FROM EXISTING RECORDS. NEITHER THE OWNER NOR THE ENGINEER ASSUMES ANY RESPONSIBILITY WHATEVER IN RESPECT TO THE ACCURACY, COMPLETENESS, OR SUFFICIENCY OF THE INFORMATION. THERE IS NO GUARANTEE, EITHER EXPRESSED OR IMPLIED, THAT THE LOCATIONS, SIZE AND TYPE OF MATERIAL OF EXISTING UNDERGROUND UTILITIES INDICATED ARE REPRESENTATIVE OF THOSE TO BE ENCOUNTERED IN THE CONSTRUCTION.

IT SHALL BE THE CONTRACTOR'S RESPONSIBILITY TO DETERMINE THE ACTUAL LOCATION OF ALL SUCH FACILITIES, INCLUDING SERVICE CONNECTIONS TO UNDER- GROUND UTILITIES. PRIOR TO CONSTRUCTION, THE CONTRACTOR SHALL NOTIFY THE UTILITY COMPANY OF HIS OPERATIONAL PLANS. THE CONTRACTOR SHALL MAKE ARRANGEMENTS FOR DETAILED INFORMATION AND ASSISTANCE IN LOCATING UTILITIES. IN THE EVENT AN UNEXPECTED UTILITY INTERFERENCE IS ENCOUNTERED DURING CONSTRUCTION, THE CONTRACTOR SHALL IMMEDIATELY NOTIFY THE UTILITY COMPANY, THE OWNER AND THE ENGINEER. ANY SUCH MAINS AND/OR SERVICES DISTURBED BY THE CONTRACTOR'S OPERATIONS SHALL BE RESTORED IMMEDIATELY AT HIS EXPENSE TO THE SATISFACTION OF THE OWNER AND THE ENGINEER.

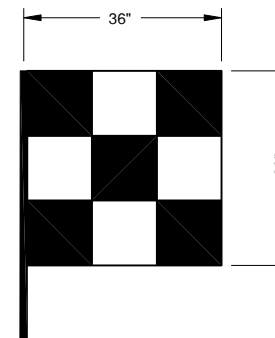

VEHICLE SIGNAL FLAG
 (ORANGE / WHITE)
 N.T.S.

GROUND CONTROL FREQUENCY 121.8 MHZ





MAXIMUM EQUIPMENT HEIGHT 25 FEET

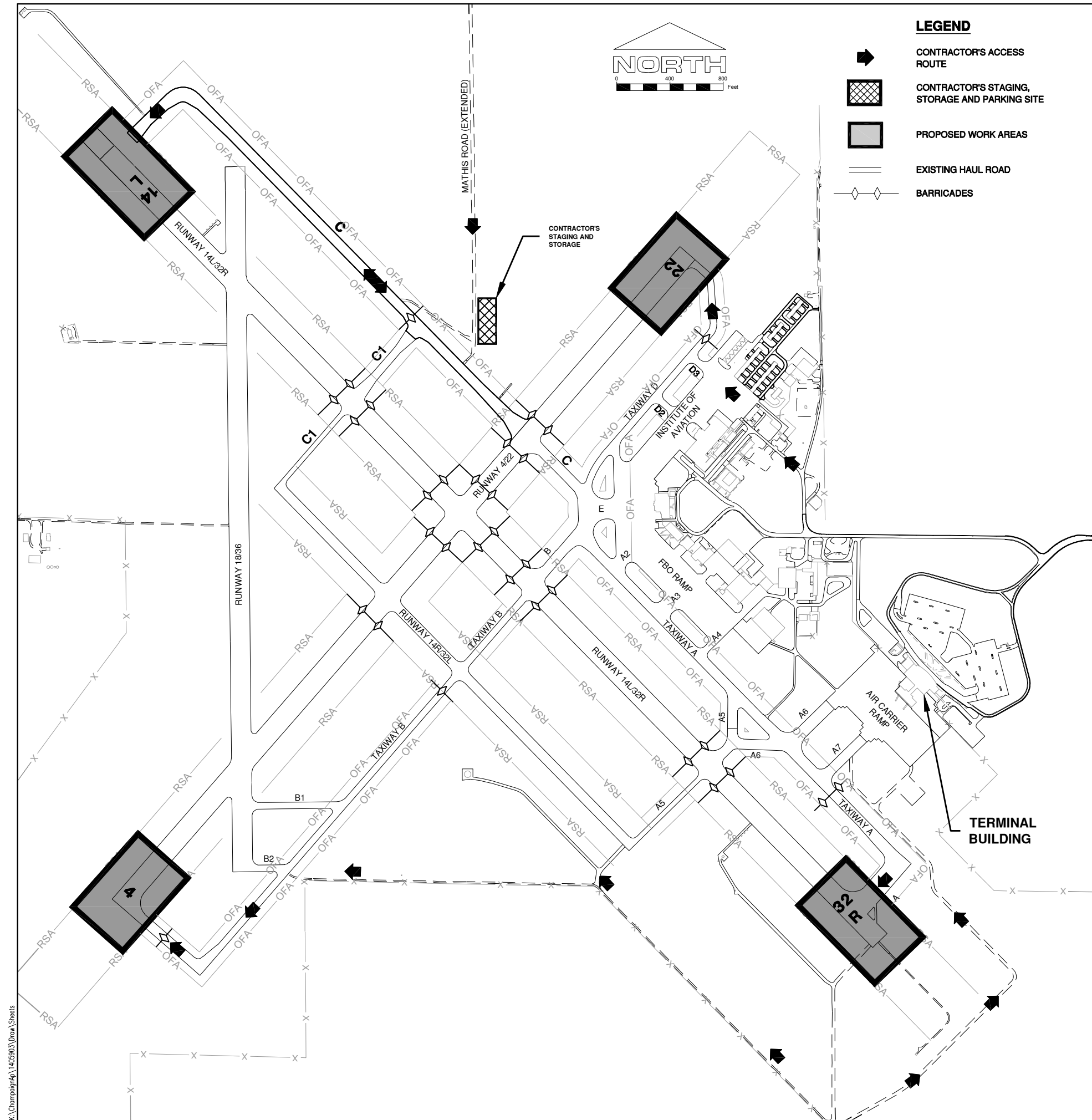

DESIGN BY:	CBG
DRAWN BY:	ADD
CHECKED BY:	CET
APPROVED BY:	CET
DATE:	MAY 01, 2015
JOB No:	14059-03
IL PROJ. NO.	CMI-4408
AIP PROJ. NO.	3-17-0016-XX
SHEET	02 OF 11 SHEETS



LEGEND

-  CONTRACTOR'S ACCESS ROUTE
-  CONTRACTOR'S STAGING, STORAGE AND PARKING SITE
-  PROPOSED WORK AREAS
-  EXISTING HAUL ROAD
-  BARRICADES

NOTES

1. CONTRACTOR ACCESS IS LIMITED TO THE AREAS SHOWN. AT NO TIME SHALL THE CONTRACTOR BE GIVEN ACCESS TO THE TERMINAL OR GENERAL AVIATION APRONS WITHOUT THE PERMISSION OF AIRPORT MANAGEMENT.
2. THE CONTRACTOR WILL BE ALLOWED TO STORE MATERIALS AND EQUIPMENT AT THE LOCATION SHOWN OFF MATHIS ROAD. ALL BARRICADE, CLOSURE X'S, EQUIPMENT AND MATERIAL SHALL BE MOVED TO THIS LOCATION AT THE END OF EACH WORKING DAY AND REMOVED FROM THE SITE AT THE END OF THE WORK.
3. EMPLOYEE PERSONAL VEHICLES SHALL NOT BE ALLOWED ON THE FIELD. EMPLOYEE PARKING SHALL BE AT THE STAGING, STORAGE AND PARKING SITE.
4. THE CONTRACTOR SHALL NOTIFY AIRPORT MANAGEMENT 5 BUSINESS DAYS PRIOR TO COMMENCING WORK.
5. BEFORE BEGINNING WORK EACH DAY, THE CONTRACTOR SHALL PLACE RUNWAY CLOSURE MARKERS ON BOTH ENDS OF THE RUNWAY BEING WORKED ON THAT DAY. BARRICADES SHALL BE PLACED IN ACCORDANCE WITH THE CONSTRUCTION ACTIVITY PLANS.
6. ONLY ONE RUNWAY SHALL BE ALLOWED TO BE CLOSED EACH DAY. THE CONTRACTOR SHALL MAKE EFFORTS TO LIMIT RUNWAY CLOSURE DURATION. WHEN POSSIBLE, THE RUNWAY SHALL BE REOPENED TO AIRCRAFT TRAFFIC AT THE CONCLUSION OF THE WORKING DAY.
7. IF IT APPEARS THE RUNWAY WILL NOT BE ABLE TO BE REOPENED TO TRAFFIC AT THE END OF WORKING HOURS, AIRPORT MANAGEMENT SHALL BE NOTIFIED AS SOON AS THAT DETERMINATION IS MADE.
8. ALL CONSTRUCTION TRAFFIC OPERATING ON OR CROSSING ACTIVE AIRFIELD PAVEMENTS SHALL CONTACT THE FAA AIR TRAFFIC CONTROL TOWER. THE CONTRACTOR SHALL PROVIDE HIS OWN RADIOS AND REMAIN IN CONTACT WITH TOWER PERSONNEL UNTIL HE LEAVES THE ACTIVE PAVEMENT AREA.
9. VEHICLES AND EQUIPMENT SHALL NOT BE ALLOWED WITHIN AREAS **130 FEET** FROM THE CENTERLINE OF ACTIVE TAXIWAYS OR **250 FEET** FROM THE CENTERLINE OF ACTIVE RUNWAYS.
10. ANY WASTE GENERATED AS PART OF THIS PROJECT SHALL BE DISPOSED OF BY THE CONTRACTOR OFF AIRPORT PROPERTY.
11. THE CONTRACTOR SHALL THOROUGHLY CLEAN ALL CONSTRUCTION AREAS PRIOR TO OPENING TO AIR TRAFFIC.
12. THE FIRE/CRASH/RESCUE VEHICLES SHALL HAVE COMPLETE ACCESS AND RIGHT OF WAY TO THE ENTIRE AIRFIELD, INCLUDING THE CLOSURE AREAS.
13. IF, DURING CONSTRUCTION, AN EMERGENCY IS DECLARED BY THE AIRPORT, THE CONTRACTOR SHALL IMMEDIATELY CLEAR THE PAVEMENT WITH ALL VEHICLES, MEN AND EQUIPMENT.
14. ALL PERSONNEL ON THE AIRFIELD WILL BE REQUIRED TO SUBMIT A TEN YEAR BACKGROUND CHECK TO AIRPORT SECURITY.
15. ALL RUNWAYS, TAXIWAYS AND APRONS SHALL BE KEPT OPEN TO AIRCRAFT TRAFFIC DURING CONSTRUCTION EXCEPT AS NOTED ABOVE.
16. ALL VEHICLES AND EQUIPMENT SHALL DISPLAY AN ORANGE AND WHITE CHECKED AVIATION FLAG, EXCEPT HAUL VEHICLES.
17. ANY VEHICLE OPERATING WITHIN A MOVEMENT AREA DURING THE HOURS OF DARKNESS SHALL BE EQUIPPED WITH AN AMBER REVOLVING OR FLASHING DOME-TYPE LIGHT AS SPECIFIED IN THE CONTRACT SPECIFICATIONS.

FILE: CMI4408-1405903-GI400.dwg
 UPDATE BY: Chris Groth
 PLOT DATE: 6/29/2015 10:57 AM

CMI-V-AERL
 CMI 1305902-C-SPAL

UN054

REVISIONS

NUMBER	BY	DATE

0 1 2
 THIS BAR IS EQUAL TO 2"
 AT FULL SCALE (34x22).

UNIVERSITY OF ILLINOIS
 WILLARD AIRPORT
 SAVOY, ILLINOIS

REMARK RUNWAY THRESHOLDS

AIRPORT SITE PLAN



© Copyright CMT, Inc. 2014
 License No. 184-000613

DESIGN BY:	CBG
DRAWN BY:	ADD
CHECKED BY:	CET
APPROVED BY:	CET
DATE:	MAY 01, 2015
JOB No:	14059-03
IL PROJ. NO. CMI-4408	
AIP PROJ. NO. 3-17-0016-XX	
SHEET 03 OF 11 SHEETS	

GENERAL

- 1. THE CONTRACTOR AND ALL SUBCONTRACTORS SHALL FOLLOW THE REQUIREMENTS OF THE AIRPORT'S APPROVED CONSTRUCTION SAFETY AND PHASING PLAN (CSPP), FAA AC 150/5370-2F, AND ALL AIRPORT SAFETY AND SECURITY REQUIREMENTS.
2. PRIOR TO THE START OF CONSTRUCTION THE CONTRACTOR SHALL SUBMIT TO THE AIRPORT FOR APPROVAL A SAFETY PLAN COMPLIANCE DOCUMENT (SPCD) IN ACCORDANCE WITH FAA AC 150/5370-2F. NO CONSTRUCTION ACTIVITY SHALL BEGIN UNTIL THE AIRPORT HAS APPROVED THE SPCD.
3. THE CSPP COVERS OPERATIONAL SAFETY. THE CONTRACTOR SHALL BE RESPONSIBLE FOR THE INDIVIDUAL SAFETY OF HIS/HER PERSONNEL AND MEETING OSHA REQUIREMENTS.
4. A MINIMUM OF 10 DAYS PRIOR TO THE NOTICE TO PROCEED THE CONTRACTOR SHALL PROVIDE A LIST OF SUBCONTRACTORS AND MATERIAL SUPPLIERS.
5. PRIOR TO THE START OF CONSTRUCTION THE CONTRACTOR SHALL SIGN THE SWPPP CERTIFICATION STATEMENT.
6. ALL CONTRACTOR COSTS ASSOCIATED WITH THE REQUIREMENTS LISTED ON THIS SHEET SHALL BE CONSIDERED INCIDENTAL TO THE CONTRACT UNLESS A SPECIFIC PAY ITEM IS PROVIDED.

1. COORDINATION

- 1. PRIOR TO THE START OF CONSTRUCTION THE CONTRACTOR SHALL ATTEND A PRECONSTRUCTION CONFERENCE WITH THE AIRPORT, ENGINEER, AND ILLINOIS DIVISION OF AERONAUTICS (IDA). THE COST OF PREPARING FOR AND ATTENDING THE PRECONSTRUCTION CONFERENCE SHALL BE INCIDENTAL TO THE CONTRACT.
2. ON OR BEFORE THE PRECONSTRUCTION CONFERENCE, THE CONTRACTOR SHALL SUBMIT A PROPOSED SCHEDULE FOR THE PROJECT. THE SCHEDULE SHALL INCLUDE A START AND COMPLETION DATE FOR EACH ITEM OF WORK. THE SCHEDULE SHALL BE UPDATED ON A WEEKLY BASIS. ALL COSTS ASSOCIATED WITH THE SCHEDULE SHALL BE INCIDENTAL TO THE CONTRACT.
3. DURING CONSTRUCTION THE CONTRACTOR SHALL ATTEND A WEEKLY COORDINATION MEETING WITH THE AIRPORT STAFF AND RESIDENT ENGINEER. ALL COSTS ASSOCIATED WITH ATTENDING THE WEEKLY MEETING SHALL BE INCIDENTAL TO THE CONTRACT.

2. PHASING

- 1. TOTAL CONTRACT TIME SHALL BE 14 CALENDAR DAYS.
2. PHASING SHALL BE AS NOTED BELOW AND AS SHOWN ON THE CONSTRUCTION ACTIVITY PLAN (CAP) SHEET.

3. AREAS AND OPERATIONS AFFECTED BY THE CONSTRUCTION ACTIVITY

- 1. ALL RUNWAYS, TAXIWAYS AND APRONS SHALL BE KEPT OPEN TO AIRCRAFT TRAFFIC DURING CONSTRUCTION EXCEPT AS NOTED ON THE PHASING PLAN.
2. WHEN CONFLICTS ARISE BETWEEN CONSTRUCTION ACTIVITIES AND AIRCRAFT OPERATIONS AND SAFETY, AIRCRAFT OPERATIONS AND SAFETY SHALL TAKE PRECEDENCE AND SHALL GOVERN. FINAL AUTHORITY IN THE APPROVAL OF CONSTRUCTION SEQUENCING LIES WITH THE AIRPORT.
3. ALL CONSTRUCTION TRAFFIC SHALL IMMEDIATELY YIELD TO ONCOMING AIRCRAFT AT ALL TIMES.

5. CONTRACTOR ACCESS

- 1. CONTRACTOR ACCESS SHALL BE AS NOTED BELOW AND AS SHOWN ON THE SITE PLAN AND CONSTRUCTION ACTIVITY PLAN SHEETS. ALL COSTS RELATING TO CONTRACTOR'S ACCESS AND SECURITY SHALL BE THE RESPONSIBILITY OF THE CONTRACTOR.
2. THE CONTRACTOR IS TO ACCESS THE SITE USING THE GATES SHOWN. THE CONTRACTOR SHALL BE RESPONSIBLE FOR KEEPING THE ACCESS GATE(S) CLOSED DURING WORK HOURS. THE CONTRACTOR SHALL POST A COMPETENT SECURITY GUARD TO CONTROL ACCESS AT THE GATE. THE CONTRACTOR SHALL REPLACE ANY UNSATISFACTORY SECURITY GUARDS AS DIRECTED.
3. CONTRACTOR SHALL OBTAIN ALL NECESSARY PERMITS AND TEMPORARY EASEMENTS FOR THE PUBLIC ACCESS ROAD(S) SHOWN AND SHALL COMPLY WITH ALL REQUIREMENTS, LOAD RESTRICTIONS, & TRAFFIC CONTROL SIGNAGE REQUIRED BY THE VILLAGE, UNIVERSITY, COUNTY, TOWNSHIP, OR I.D.O.T.
4. A MINIMUM OF THREE (3) CONTRACTOR EMPLOYEES SHALL OBTAIN AN AIRPORT IDENTIFICATION BADGE. THIS CONSISTS OF FILLING OUT ALL NECESSARY PAPERWORK, FINGERPRINTING, ATTENDING AND PASSING A TRAINING CLASS CONCERNING SAFETY AND SECURITY AT THE AIRPORT. CONTRACTOR EMPLOYEES MUST MEET CERTAIN BACKGROUND CHECK CRITERIA AND THE CONTRACTOR MUST MAKE CERTAIN CERTIFICATION ABOUT EACH EMPLOYEE. THE CONTRACTOR SHALL BE RESPONSIBLE FOR FINGERPRINTING COSTS. ALL COSTS ASSOCIATED WITH OBTAINING THE IDENTIFICATION BADGE SHALL BE BORNE BY THE CONTRACTOR.

- 5. ALL CONTRACTOR EMPLOYEES WHO ARE DESIGNATED AS DRIVERS FOR THE CONTRACTOR WITHIN THE AIRFIELD OPERATIONS AREA (AOA) SHALL ALSO ATTEND AND PASS THE AIRPORT DRIVERS TRAINING PROGRAM. ONLY THOSE INDIVIDUALS WHO RECEIVE THIS DESIGNATION WILL BE PERMITTED TO OPERATE VEHICLES OR EQUIPMENT ON THE AIRPORT. ALL COSTS ASSOCIATED WITH THE DRIVER TRAINING PROGRAM SHALL BE BORNE BY THE CONTRACTOR.
6. CONTRACTOR'S VEHICLES AND EQUIPMENT SHALL BE MARKED AND FLAGGED PER SECTION 70-10 OF THE STANDARD SPECIFICATIONS. MAXIMUM HEIGHT OF CONTRACTOR'S EQUIPMENT WILL BE 25'.
7. DRIVERS OF TRUCKS CONTAINING MATERIAL DELIVERIES (AGGREGATE, CONCRETE, ETC.) NEED NOT OBTAIN AN AIRPORT ID BADGE BUT SHALL BE REQUIRED TO SUBMIT THEIR NAME, DRIVER'S LICENSE NUMBER, TRUCK LICENSE PLATE NUMBER AND NAME OF TRUCKING COMPANY TO THE PRIME CONTRACTOR PRIOR TO ENTERING THE JOBSITE. WHILE INSIDE THE AOA, THE TRUCK DRIVERS SHALL BE ESCORTED BY THE CONTRACTOR PERSONNEL THAT HAS OBTAINED PROPER DRIVING PRIVILEGES.

- 8. CONTRACTOR WORK CREWS MUST MAINTAIN RADIO CONTACT WITH THE AIR TRAFFIC CONTROL TOWER (ATCT) AT ALL TIMES WHEN INSIDE THE AIRPORT OPERATIONS AREA (AOA). THE CONTRACTOR SHALL SUPPLY ALL APPROPRIATE RADIOS NEEDED FOR COMMUNICATIONS AND ONLY HIS PERSONNEL WHO HAVE SUCCESSFULLY COMPLETED THE APPROVED CMI/FAA SAFETY COURSE MAY OPERATE THESE RADIOS.
9. THE CONTRACTORS STORAGE AND STAGING AREA WILL BE AS SHOWN IN THE SITE PLAN

- 10. THE CONTRACTOR SHALL KEEP A RECORD OF THE NAMES OF ALL EMPLOYEES ENTERING THE JOB SITE ON A DAILY BASIS. A RECORD OF EACH SUBCONTRACTOR ENTERING THE JOB SITE SHALL ALSO BE KEPT BY THE CONTRACTOR.

- 11. WHEN THE CONTRACTOR IS NOT WORKING, EQUIPMENT SHALL BE STORED AT THE STAGING AREA.

- 12. DURING ADVERSE WEATHER THE CONTRACTOR SHALL MAINTAIN ACCESS TO THE WORK AT NO ADDITIONAL COST TO THE CONTRACT. NO EXTENSION OF THE CONTRACT TIME WILL BE CONSIDERED FOR DELAYS DUE TO LACK OF ADEQUATE ACCESS TO THE WORK SITE.

- 13. THE CONTRACTOR WILL BE PERMITTED TO STORE EQUIPMENT AND MATERIALS ONLY AT THE LOCATIONS SHOWN. PARKED EQUIPMENT AND MATERIAL STOCKPILES SHALL NOT PENETRATE SURFACES DEFINED BY F.A.R. TITLE 14 PART 77 - OBJECTS AFFECTING NAVIGABLE AIRSPACE. EXISTING TURF AREAS DISTURBED BY THE CONTRACTOR'S OPERATIONS SHALL BE RESTORED BY HIM AT HIS EXPENSE TO THE SATISFACTION OF THE RESIDENT ENGINEER AND THE AIRPORT.

- 14. ALL CONSTRUCTION TRAFFIC OPERATING ON, OR CROSSING RUNWAYS, TAXIWAYS AND APRONS OPEN TO AIRCRAFT TRAFFIC SHALL BE UNDER CONTROL BY A FLAGMAN OR ESCORT IN RADIO CONTACT WITH THE ATCT. THE CONTRACTOR SHALL PROVIDE HIS OWN FLAGMEN.

- 15. THE CONTRACTOR SHALL THOROUGHLY CLEAN ALL CONSTRUCTION AREAS AND HAUL ROUTES WHICH WILL BE OPENED TO AIR TRAFFIC TO THE SATISFACTION OF AIRPORT OPERATIONS OR THE RESIDENT ENGINEER. A POWER BROOM AND OPERATOR SHALL BE ON SITE AT ALL TIMES WHEN ACTIVE PAVEMENTS ARE UTILIZED FOR CONSTRUCTION TRAFFIC.

5. CONTRACTOR ACCESS (CONTINUED)

- 16. ALL PAVEMENTS, DRIVES OR ANY OTHER AREAS UTILIZED BY THE CONTRACTOR FOR HAUL ROADS OR STORAGE AREAS SHALL BE MAINTAINED AND REPAIRED TO THE SAME CONDITION OR BETTER THAN THEY WERE PRIOR TO BEGINNING CONSTRUCTION. NO ADDITIONAL COMPENSATION WILL BE MADE TO THE CONTRACTOR FOR THIS WORK.
17. ALL VEHICLE AND EQUIPMENT OPERATORS USED BY THE CONTRACTOR SHALL BE PROPERLY TRAINED BY THE CONTRACTOR.
18. THE CONTRACTOR SHALL NOTIFY THE AIRCRAFT RESCUE AND FIRE FIGHTING (ARFF) FACILITY IF CONSTRUCTION ACTIVITY WILL REQUIRE THE BLOCKAGE OF EMERGENCY ACCESS TO THE AIRPORT.

6. WILDLIFE MANAGEMENT

- 1. THE CONTRACTOR SHALL NOTIFY PUBLIC SAFETY OR THE ENGINEER IF ANY WILDLIFE IS SEEN ENTERING THE AIRPORT.
2. CONTRACTOR ACCESS GATES SHALL REMAIN CLOSED WHEN THE CONTRACTOR IS NOT WORKING.
3. THE CONTRACTOR SHALL DISPOSE OF ALL TRASH INCLUDING FOOD SCRAPS IN APPROVED CONTRACTOR PROVIDED CONTAINERS.

7. NOTIFICATION OF CONSTRUCTION ACTIVITIES

- 1. THE CONTRACTOR SHALL PROVIDE A 24 HOUR EMERGENCY CONTACT PERSON AND PHONE NUMBER.
2. THE CONTRACTOR SHALL GIVE A MINIMUM OF 72 HOURS NOTICE TO AIRPORT OPERATIONS PRIOR TO CLOSING ANY PAVEMENTS SO THAT PROPER NOTAMS MAY BE ISSUED BY THE AIRPORT.
3. FOR ANY EQUIPMENT USED BY THE CONTRACTOR WITH A HEIGHT GREATER THAN 25', THE CONTRACTOR SHALL PROVIDE TO THE AIRPORT THE TYPE OF EQUIPMENT, TOTAL HEIGHT, AND LOCATION WHERE THE EQUIPMENT WILL BE USED. THE AIRPORT WILL SUBMIT FAA FORM 7460-1 TO THE FAA FOR AN AIRSPACE STUDY. NO EQUIPMENT WITH A HEIGHT GREATER THAN 40' SHALL BE USED UNTIL A DETERMINATION FROM FAA IS RECEIVED.
4. IN THE EVENT OF AN EMERGENCY, THE CONTRACTOR SHALL CALL 911.
5. CONTACTS FOR THIS PROJECT ARE AS LISTED BELOW.
PUBLIC SAFETY
JOHN RIEGEL - FIRE CHIEF
OFFICE (217) 244-8764
CELL (217) 202-8213
AIRPORT MAINTENANCE
RON DECKARD - MAINTENANCE CONTACT
OFFICE (217) 369-0099
CELL (217) 714-4600
ENGINEER
CHRIS GROTH P.E. - PROJECT ENGINEER
(217) 787-8050
RESIDENT ENGINEER TO BE DETERMINED
OFFICE (217) 787-8050

8. INSPECTION REQUIREMENTS

- 1. THE CONTRACTOR SHALL INSPECT THE JOBSITE DAILY TO ENSURE COMPLIANCE WITH THE CSPP. THE CHECKLIST FOUND IN APPENDIX 3 OF FAA AC 150/5370-2F MAY BE USED TO AID IN THE INSPECTIONS.
2. THE CONTRACTOR SHALL REQUEST OPERATIONAL INSPECTION OF EACH PHASE WORK AREA PRIOR THE AREA BEING REOPENED. PUBLIC SAFETY WILL DETERMINE IF THE WORK AREA IS ALLOWED TO BE OPENED.

9. UNDERGROUND UTILITIES

- 1. IT WILL BE NECESSARY FOR THE CONTRACTOR TO MAKE HIS OWN FIELD INVESTIGATION TO DETERMINE THE EXACT LOCATION OF THE UNDERGROUND UTILITIES AT CRITICAL POINTS. THE LOCATION OF UNDERGROUND UTILITIES AS INDICATED ON THE PLANS HAS BEEN OBTAINED FROM EXISTING RECORDS. NEITHER THE OWNER NOR THE ENGINEER ASSUMES ANY RESPONSIBILITY IN RESPECT TO THE ACCURACY, COMPLETENESS OR SUFFICIENCY OF THE INFORMATION. ANY UTILITY, INCLUDING AIRFIELD ELECTRICAL CABLE AND LIGHTS, DAMAGED BY THE CONTRACTOR SHALL BE REPAIRED BY HIM AT HIS OWN EXPENSE IN A MANNER WHICH IS SATISFACTORY TO THE ENGINEER AND TO THE OWNER OF THE UTILITY. ANY REPAIRS THAT MUST BE MADE BY THE OWNER OF THE UTILITY SHALL HAVE THE COST REIMBURSED TO THE UTILITY BY THE CONTRACTOR. AIRFIELD LIGHTING CABLES DAMAGED BY THE CONTRACTOR SHALL BE REPAIRED BY A QUALIFIED ELECTRICIAN WITH THE COSTS TO BE BORNE BY THE CONTRACTOR.
2. BEFORE INITIATING ANY DIGGING, DRILLING OR EXCAVATING ON THE AIRPORT PROPERTY, THE CONTRACTOR SHALL CALL J.U.L.I.E. AND CONTACT THE LOCAL FAA OFFICE TO ARRANGE FOR UTILITY LOCATES. SEE SECTION 50-17 OF THE SPECIAL PROVISIONS FOR UTILITY CONTACT INFORMATION.

10. PENALTIES

- 1. NONCOMPLIANCE BY THE CONTRACTOR WITH AIRPORT RULES AND REGULATIONS OR FAILURE TO COMPLY WITH THE AIRPORT'S APPROVED CSPP AND THE CONTRACTOR'S APPROVED SPCD MAY RESULT IN FINES AS ALLOWED BY LAW.

11. SPECIAL CONDITIONS

- 1. ADJACENT CONSTRUCTION MAY IMPACT THE OPERATIONS OF THE CONTRACTOR. SEE THE COORDINATION NOTES FOR ADDITIONAL INFORMATION.

12. RUNWAY AND TAXIWAY VISUAL AIDS

- 1. ALL RUNWAYS, TAXIWAYS, AND APRONS SHALL BE KEPT OPEN TO AIRPORT TRAFFIC DURING CONSTRUCTION EXCEPT AS NOTED IN THE CONSTRUCTION ACTIVITY PLAN.
2. IF ANY RUNWAY OR TAXIWAY CLOSURES ARE REQUESTED BY THE CONTRACTOR AND APPROVED BY THE AIRPORT, THE CONTRACTOR SHALL USE MARKING, LIGHTING AND SIGNS THAT FOLLOWING THE REQUIREMENTS OF FAA AC 150/5370-2F.

13. MARKING AND SIGNS FOR ACCESS ROUTES

- 1. BARRICADES AND SIGNS SHALL BE USED ALONG THE CONTRACTOR'S ACCESS ROUTE AS DETAILED ON THIS SHEET AND THE CONSTRUCTION ACTIVITY PLAN SHEET.

14. HAZARD MARKING AND LIGHTING

- 1. THE CONTRACTOR SHALL FURNISH, ERECT, AND MAINTAIN MARKINGS AND ASSOCIATED LIGHTING OF OPEN TRENCHES, EXCAVATIONS, TEMPORARY STOCKPILES, AND HIS/HER CONSTRUCTION EQUIPMENT.
2. ALL CONSTRUCTION EQUIPMENT SHALL BE FLAGGED AND/OR LIGHTED IN ACCORDANCE WITH FAA ADVISORY CIRCULAR 150/5370-2F AND 150/5210-5C AT ALL TIMES WHILE OPERATING ON AIRPORT PROPERTY. THE MAXIMUM EQUIPMENT HEIGHT IS 25'.
3. BARRICADES SHALL BE PLACED AT THE LOCATIONS SHOWN ON THE CONSTRUCTION ACTIVITY PLAN SHEET OR AS DIRECTED BY THE ENGINEER.
4. THE CONTRACTOR SHALL INSPECT THE BARRICADES ONCE DURING EACH WORK DAY TO INSURE PROPER PLACEMENT AND PROPER OPERATION OF THE RED LIGHTS AND FLAG PLACEMENT.
5. THE AIRPORT WILL PROVIDE TWO PORTABLE CLOSED RUNWAY MARKERS FOR USE DURING THE PROJECT. THE CONTRACTOR WILL BE RESPONSIBLE FOR MAINTENANCE OF THE RUNWAY CLOSURE MARKERS INCLUDING FUEL, OIL CHANGES AND REPLACEMENT OF THE LIGHTS. UPON COMPLETION OF THE PROJECT, THE PORTABLE CLOSED RUNWAY MARKERS SHALL BE TURNED OVER TO THE AIRPORT.

15. PROTECTION

- 1. ALL WORK REQUIRED INSIDE OF THE RUNWAY 4-22 OR 14L/32R SAFETY AREAS, WHICH EXTENDS 250' FROM THE RUNWAY CENTERLINE, WILL REQUIRE THE RUNWAY TO BE CLOSED. THE CONTRACTOR SHALL COORDINATE WITH THE AIRPORT A MINIMUM OF 72 HOURS PRIOR TO THE REQUESTED CLOSURE TIME.
2. ALL WORK REQUIRED ON AN ACTIVE TAXIWAY OR INSIDE OF AN ACTIVE TAXIWAY OBJECT FREE AREA, WHICH EXTENDS 93' FROM THE TAXIWAY CENTERLINE OF 50' TAXIWAYS AND 130' FROM THE CENTERLINE OF 75' TAXIWAYS, WILL REQUIRE THE TAXIWAY TO BE CLOSED. THE CONTRACTOR SHALL COORDINATE WITH THE AIRPORT A MINIMUM OF 72 HOURS PRIOR TO THE REQUESTED CLOSURE TIME.
3. ALL WORK REQUIRED ON AN ACTIVE APRON OR INSIDE OF AN ACTIVE SAFETY AREA, WHICH EXTENDS 70' FROM THE APRON'S EDGE OF PAVEMENT, WILL REQUIRE A PORTION OF THAT APRON TO BE CLOSED. THE CONTRACTOR SHALL COORDINATE WITH THE AIRPORT A MINIMUM OF 72 HOURS PRIOR TO THE REQUESTED CLOSURE TIME.

16. OTHER LIMITATIONS ON CONSTRUCTION

- 1. IF, DURING CONSTRUCTION, AN EMERGENCY IS DECLARED BY THE AIRPORT, THE CONTRACTOR SHALL IMMEDIATELY CLEAR THE PAVEMENT OF ALL VEHICLES, PERSONNEL AND EQUIPMENT.
2. BROKEN CONCRETE, BROKEN ASPHALT, RUBBISH FROM DEMO, AND OTHER MISCELLANEOUS DEBRIS SHALL BE DISPOSED OF OFF AIRPORT PROPERTY, UNLESS OTHERWISE SPECIFIED.
3. THE CONTRACTOR WILL BE RESPONSIBLE FOR COORDINATING THE AIRSPACE FOR THE CONSTRUCTION EQUIPMENT THAT IS TALLER THAN THAT SPECIFIED ON THE PLANS WITH THE FAA. THIS PROCESS MAY TAKE UP TO 12 WEEKS TO COMPLETE.
4. THE CONTRACTOR SHALL BE RESPONSIBLE FOR MEGGAR TESTING ALL EXISTING CIRCUITS PRIOR TO CONSTRUCTION AND FOLLOWING CONSTRUCTION AS SPECIFIED IN THE CONTRACT DOCUMENTS.

UN054

REVISIONS

Table with 3 columns: NUMBER, BY, DATE

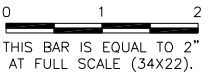

UNIVERSITY OF ILLINOIS
WILLARD AIRPORT
SAVOY, ILLINOIS

REMARK RUNWAY THRESHOLDS

CONSTRUCTION SAFETY PHASING NOTES



© Copyright CMT, Inc. 2014
License No. 194-006013

Table with 2 columns: Field Name, Value. Fields include DESIGN BY, DRAWN BY, CHECKED BY, APPROVED BY, DATE, JOB No, and SHEET information.

SEQUENCE OF CONSTRUCTION NOTES

THE GENERAL PROGRESSION OF THE WORK SHALL BE AS FOLLOWS:

- SUBMIT EQUIPMENT AND BUILDING SHOP, PLAN AND WORKING DRAWINGS FOR REVIEW. INCLUDE WITH THE SUBMITTALS ALL BUY AMERICAN CERTIFICATIONS FOR ALL MATERIALS.
- SUBMIT NOTICE OF OBSTRUCTION EVALUATION- AIRPORT AIRSPACE ANALYSIS (OE/AAA) INFORMATION FOR ANTICIPATED EQUIPMENT HEIGHTS IF IN EXCESS OF 25'. NOTE THAT THIS PROCESS MAY REQUIRE UP TO 90 DAYS FOR FAA APPROVAL. EQUIPMENT ABOVE 25' HEIGHT SHALL NOT BE UTILIZED UNTIL FAA APPROVAL HAS BEEN PROVIDED.
- SUBMIT PROJECT SCHEDULE SHOWING RELATIONSHIP BETWEEN CONSTRUCTION DURATION FOR PAY ITEMS IN RELATION TO THE PHASES OF WORK WHERE THEY ARE BEING PERFORMED. CLEARLY IDENTIFY DATES OF RUNWAY CLOSURES AND WHAT PHASES WILL BE WORKED IN DURING THAT CLOSURE.
- SUBMIT PRELIMINARY MATERIALS CERTIFICATIONS INCLUDING BUY AMERICAN CERTIFICATIONS AND WAIVER REQUEST FOR MATERIALS THAT DO NOT MEET THE CONTRACT REQUIREMENTS.
- INITIATE CONSTRUCTION OF THRESHOLD REMARKING. INSTALL BARRICADES AS OUTLINED ON THE CONSTRUCTION ACTIVITY PLANS. FIELD VERIFY LOCATION OF EXISTING MARKINGS.
- INITIATE CONSTRUCTION WITHIN THE VARIOUS PHASES OF THE PROJECT. RUNWAY 14L/32R PHASES SHALL BE CONSIDERED THE PRIMARY WORK AREAS. WORK IN THESE AREAS SHALL INCLUDE REMOVAL OF PAVEMENT MARKING AND REMARKING.
- UPON COMPLETION OF ALL PHASES, THE CONTRACTOR SHALL REQUEST A FINAL INSPECTION OF THE PROJECT.

RUNWAY SAFETY AREAS

- WORK IN THE RUNWAY 14L/32R SAFETY AREA (250' FROM THE RUNWAY CENTERLINE) SHALL BE LIMITED TO THAT WORK NECESSARY TO REMOVE AND REMARK RUNWAY THRESHOLD MARKINGS. NO PAVEMENT IMPROVEMENTS WILL BE MADE TO THE SURFACE OF RUNWAY 14L/32R.
- WORK IN THE RUNWAY 4/22 SAFETY AREA SHALL BE LIMITED TO THAT WORK NECESSARY TO REMOVE AND REMARK RUNWAY THRESHOLD MARKINGS.
- RUNWAY 4/22 AND RUNWAY 14L/32R SHALL NOT BE CLOSED AT THE SAME TIME.
- EQUIPMENT OR PERSONNEL SHALL REMAIN CLEAR OF THE RUNWAY PAVEMENTS AT ALL TIMES.
- NO EQUIPMENT, STOCKPILES OR EXCAVATIONS SHALL REMAIN INSIDE THE RUNWAY SAFETY AREAS AFTER WORKING HOURS.

APRON / TAXIWAY OBJECT FREE AREAS

- WORK IN THE TAXIWAY OBJECT FREE AREAS (130' FOR ALL 75' WIDE TAXIWAYS AND 93' FOR ALL 50' WIDE TAXIWAYS FROM THE TAXIWAY CENTERLINE) AND SHALL REQUIRE THAT TAXIWAY TO BE CLOSED. WORK LIMITS SHALL REMAIN OUTSIDE OF THE TAXIWAY OBJECT FREE AREA.
- NO EQUIPMENT, OPEN TRENCHES OR EXCAVATIONS SHALL REMAIN INSIDE THE TAXIWAY OBJECT FREE AREAS AFTER WORKING HOURS.
- THE TAXIWAYS OR EDGES OF APRONS SHALL BE CLOSED WITH BARRICADES AT 15' MAXIMUM SPACING PRIOR TO WORKING IN THE CRITICAL WORK AREAS.
- EXIT TAXIWAYS WILL ONLY BE CLOSED WHEN THE RUNWAY THAT THEY CONNECT TO ARE ALSO CLOSED. TAXIWAY CLOSURE MARKERS WILL NOT BE REQUIRED WHERE A TAXIWAY CLOSURE IS ADJACENT TO A RUNWAY CLOSURE.

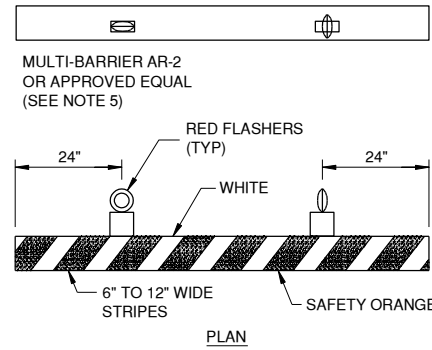

BARRICADE NOTES:

- FLASHERS SHALL BE BATTERY OPERATED. LENS SHALL BE RED AND BE ABLE TO ROTATE 90°.
- FACING OF BARRICADE SHALL BE COVERED WITH REFLECTIVE TAPE OR PAINT.
- BARRICADES TO BE PLACED WITH A MAXIMUM OF 15' SPACING BETWEEN ENDS OF BARRICADES ALONG OPERATIONAL PAVEMENT ADJACENT TO CONSTRUCTION OR AS DIRECTED BY THE RESIDENT ENGINEER. ALTERNATE FLASHER LENSES SO THAT EVERY OTHER LENS IS ROTATED 90°.
- FLASHERS SHALL BE SECURED TO THE BARRICADES, AS APPROVED BY THE RESIDENT ENGINEER.
- BARRICADES SHALL BE OF LOW MASS, EASILY COLLAPSIBLE UPON CONTACT WITH AN AIRCRAFT OR ANY OF IT COMPONENTS, AND WEIGHTED OR STURDILY ATTACHED TO THE SURFACE. IF AFFIXED TO THE SURFACE, THE BARRICADE MUST BE FRANGIBLE AT GRADE LEVEL OR LOW AS POSSIBLE, BUT NOT TO EXCEED 3 INCHES ABOVE THE GROUND.

LOW PROFILE LIGHTED BARRICADE

NTS

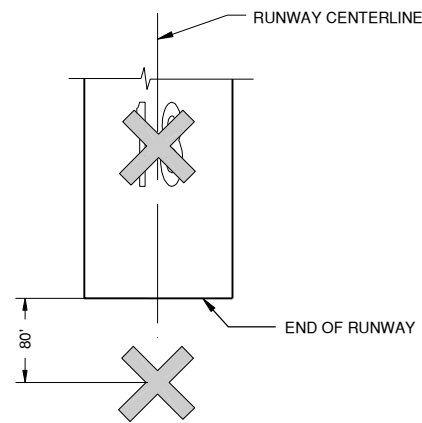

CLOSED RUNWAY MARKER DETAIL

N.T.S.

NOTES

- MARKERS SHALL BE SOLID YELLOW.
- MARKERS SHALL BE SELF CONTAINED MOBILE MARKERS PROVIDED BY THE CONTRACTOR THROUGH THE CONTRACT.
- CONTRACTOR SHALL MAINTAIN MARKERS.
- COST OF INSTALLING, MAINTAINING, RELOCATING AND REMOVING MARKERS SHALL BE INCIDENTAL TO THE CONTRACT.
- MARKERS SHALL BE PLACED OVER EXISTING RUNWAY NUMERALS.

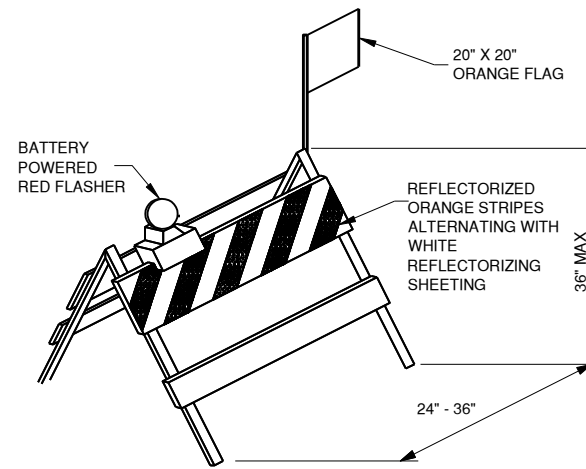

NOTE:

BARRICADES SHALL BE PLACED AS SHOWN ON THE CONSTRUCTION ACTIVITY PLANS 15' ON CENTER AT DESIGNATED LOCATIONS. BARRICADE SHALL BE WEIGHTED WITH A MINIMUM OF 6 SAND BAGS TO PREVENT THEM FROM BEING BLOWN OVER.

IDOT TYPE 1 BARRICADE DETAIL

NOTE:

WHERE NOT SPECIFIED, THE CONTRACTOR SHALL HAVE THE OPTION AS TO WHICH TYPE OF BARRICADE IS USED.

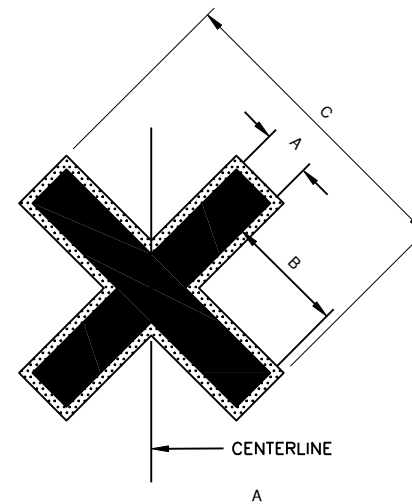

CLOSED RUNWAY/ TAXIWAY MARKER DETAIL

N.T.S.

SYMBOL TYPE	DIMENSION		
	A	B	C
CLOSED RUNWAY	10'-0"	25'-0"	60'-0"
CLOSED TAXIWAY	5'-0"	12'-6"	30'-0"

NOTES

- CLOSURE MARKERS SHALL BE SOLID YELLOW.
- MARKERS SHALL BE PLACED ON TAXIWAYS AT THE RUNWAY INTERSECTIONS INSIDE THE RUNWAY SAFETY AREA.
- MARKERS SHALL BE PAINTED ON THE TAXIWAY USING TEMPORARY PAINT OR CONSTRUCTED OF FABRIC, COLORED PLASTIC, PAINTED SHEETS OF PLYWOOD OR SIMILAR MATERIALS.
- NON PAINTED MARKERS SHALL BE SECURED TO PREVENT MOVEMENT BY PROP WASH, JET BLAST OR OTHER WIND CURRENTS. METHODS OF SECURING THE MARKERS SHALL NOT PROTRUDE MORE THAN 3" ABOVE THE PAVEMENT STRUCTURE

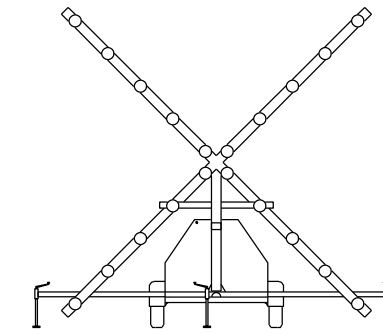

LIGHTED RUNWAY CLOSURE MARKER

N.T.S.

NOTES

- TO BE PLACED ON PAVEMENT AT THE RUNWAY NUMERALS.
- PAIR OF LIGHTED 'X'S TO BE PROVIDED BY THE AIRPORT. THE CONTRACTOR SHALL BE RESPONSIBLE FOR MAINTENANCE (FUEL, OIL, LIGHT BULBS) WHEN USED DURING CONSTRUCTION CLOSURES.

UN054

REVISIONS

NUMBER	BY	DATE

0 1 2
 THIS BAR IS EQUAL TO 2"
 AT FULL SCALE (34X22).

UNIVERSITY OF ILLINOIS
 WILLARD AIRPORT
 SAVOY, ILLINOIS

REMARK RUNWAY THRESHOLDS

CONSTRUCTION ACTIVITY PLAN NOTES & DETAILS



© Copyright CMT, Inc. 2014
 License No. 194-006013

DESIGN BY:	CBG
DRAWN BY:	ADD
CHECKED BY:	CET
APPROVED BY:	CET
DATE:	MAY 01, 2015
JOB No:	14059-03
IL PROJ. NO.	CMI-4408
AIP PROJ. NO.	3-17-0016-XX
SHEET	05 OF 11 SHEETS

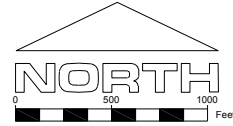

CONSTRUCTION ACTIVITY PLAN PHASE 1 NOTES

1. CONTRACTOR TO SET UP BARRICADES AND RUNWAY CLOSURE MARKERS AS SHOWN PRIOR TO BEGINNING WORK.
2. PHASE 1 AND 2 SHALL NOT BE CONCURRENT. ONLY ONE RUNWAY SHALL BE CLOSED AT ONE TIME.
3. RUNWAY 14L/32R SHALL BE OPENED AT THE END OF EACH WORKING DAY. AS A MINIMUM, AT LEAST ONE COAT OF PAINT FOR THE NEW MARKINGS SHALL BE COMPLETED. THE CONTRACTOR SHALL NOTIFY THE RESIDENT ENGINEER IF NOT ALL MARKING WILL BE ABLE TO BE COMPLETED THAT DAY.
4. THE CONTRACTOR CREWS SHALL REMAIN IN CONTACT WITH THE AIRPORT ESCORT THROUGHOUT THE DAY WHEN HE/SHE IS WORKING ON OR NEAR ACTIVE AIRPORT PAVEMENTS.
5. BARRICADES SHOWN ARE REQUIRED AT A MINIMUM 10' SPACING ON THE HARD SURFACE OF THE RUNWAY OR TAXIWAY.

CRITICAL POINT TABLE					
POINT	LATITUDE	LONGITUDE	GROUND ELEVATION	ABOVE GROUND	TOP ELEVATION
CP 1	N 040° 02' 51.4387"	W 088° 17' 12.9242"	752.00	25'	777
CP 2	N 040° 02' 45.3464"	W 088° 17' 05.3278"	750.00	25'	775
CP 3	N 040° 02' 47.7395"	W 088° 17' 02.0784"	750.00	25'	775
CP 4	N 040° 02' 53.8319"	W 088° 17' 09.6748"	754.00	25'	779
CP 5	N 040° 01' 58.1490"	W 088° 15' 58.6927"	746.00	25'	771
CP 6	N 040° 01' 55.7564"	W 088° 16' 01.9421"	746.00	25'	771
CP 7	N 040° 01' 49.9037"	W 088° 15' 54.6494"	746.00	25'	771
CP 8	N 040° 01' 52.2962"	W 088° 15' 51.3999"	746.00	25'	771

FILE: CMI4382-1405902-GP402.dwg
 UPDATE BY: Chris Groth
 PLOT DATE: 6/29/2015 10:58 AM

CMI-V-AERL
 CMI 1305902-C-SPAL
 CMI 1405902-C-SPAL

UN054

REVISIONS

NUMBER	BY	DATE

0 1 2
 THIS BAR IS EQUAL TO 2"
 AT FULL SCALE (34X22).

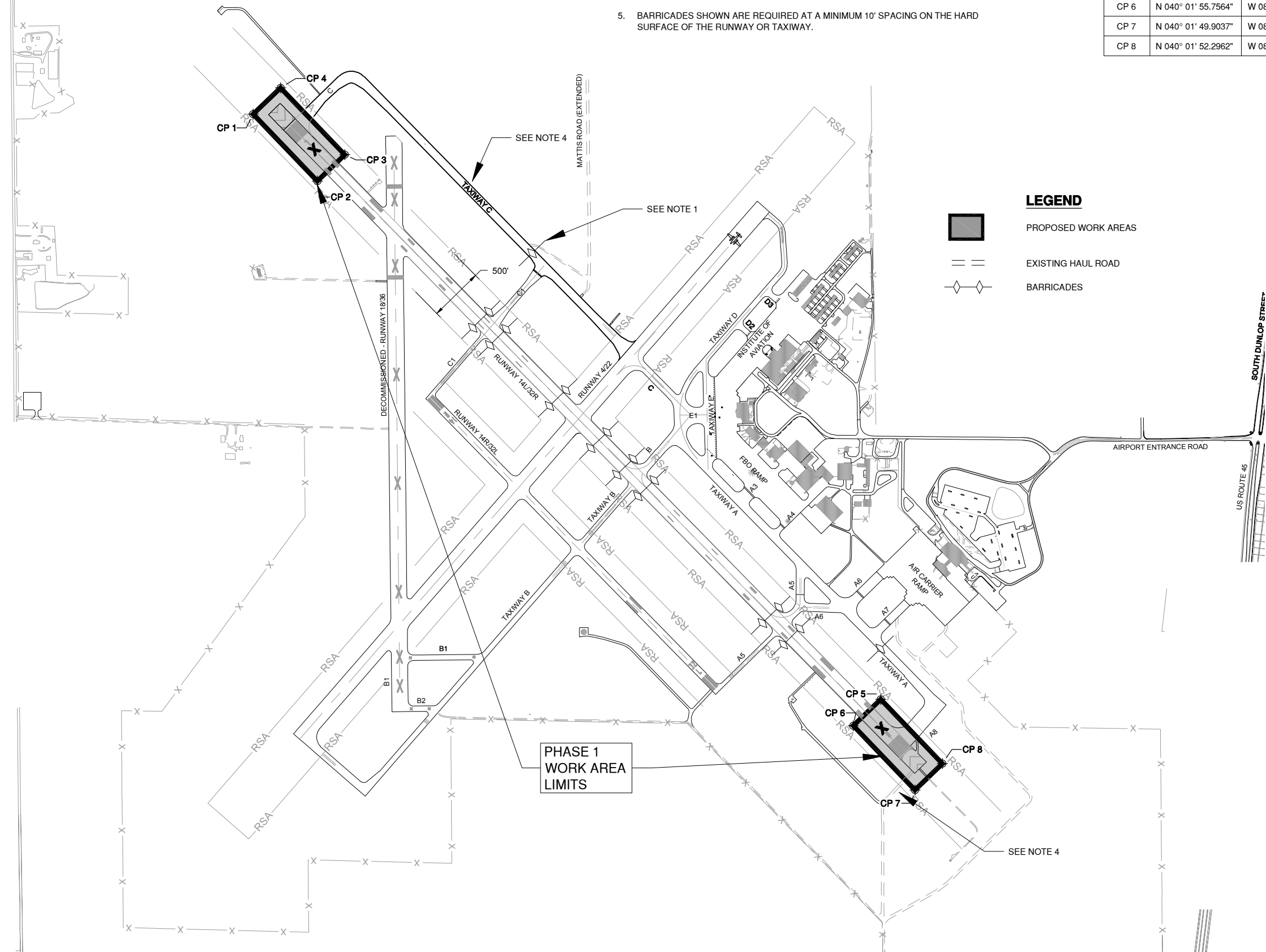

UNIVERSITY OF ILLINOIS
 WILLARD AIRPORT
 SAVOY, ILLINOIS

REMARK RUNWAY THRESHOLDS CONSTRUCTION ACTIVITY PLAN - PHASE 1



© Copyright CMT, Inc. 2014
 License No. 184-000613

DESIGN BY:	CBG
DRAWN BY:	ADD
CHECKED BY:	CET
APPROVED BY:	CET
DATE:	MAY 01, 2015
JOB No:	14059-03
IL PROJ. NO.	CMI-4408
AIP PROJ. NO.	3-17-0016-XX
SHEET	06 OF 11 SHEETS

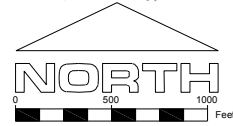

CONSTRUCTION ACTIVITY PLAN PHASE 1 NOTES

1. CONTRACTOR TO SET UP BARRICADES AND RUNWAY CLOSURE MARKERS AS SHOWN PRIOR TO BEGINNING WORK.
2. PHASE 1 AND 2 SHALL NOT BE CONCURRENT. ONLY ONE RUNWAY SHALL BE CLOSED AT ONE TIME.
3. RUNWAY 4/22 SHALL BE OPENED AT THE END OF EACH WORKING DAY. AS A MINIMUM, AT LEAST ONE COAT OF PAINT FOR THE NEW MARKINGS SHALL BE COMPLETED. THE CONTRACTOR SHALL NOTIFY THE RESIDENT ENGINEER IF NOT ALL MARKING WILL BE ABLE TO BE COMPLETED THAT DAY.
4. THE CONTRACTOR CREWS SHALL REMAIN IN CONTACT WITH THE AIRPORT ESCORT THROUGHOUT THE DAY WHEN HE/SHE IS WORKING ON OR NEAR ACTIVE AIRPORT PAVEMENTS.
5. BARRICADES SHOWN ARE REQUIRED AT A MINIMUM 10' SPACING ON THE HARD SURFACE OF THE RUNWAY OR TAXIWAY.

CRITICAL POINT TABLE					
POINT	LATITUDE	LONGITUDE	GROUND ELEVATION	ABOVE GROUND	TOP ELEVATION
CP 1	N 040° 02' 40.0893"	W 088° 16' 18.8428"	745.00	25'	777
CP 2	N 040° 02' 37.8544"	W 088° 16' 15.3913"	744.00	25'	775
CP 3	N 040° 02' 43.3409"	W 088° 16' 09.1690"	746.00	25'	775
CP 4	N 040° 02' 45.6133"	W 088° 16' 12.5619"	745.00	25'	779
CP 5	N 040° 01' 59.6524"	W 088° 17' 04.5792"	748.00	25'	771
CP 6	N 040° 01' 54.2364"	W 088° 17' 10.8572"	746.00	25'	771
CP 7	N 040° 01' 51.9291"	W 088° 17' 07.5049"	748.00	25'	771
CP 8	N 040° 01' 57.3451"	W 088° 17' 01.2269"	747.00	25'	771

FILE: CMI4382-1405902-GP403.dwg
 UPDATE BY: Chris Groth
 PLOT DATE: 6/29/2015 10:58 AM

CMI-V-AERL
 CMI 1305902-C-SPAL
 CMI 1405902-C-SPAL

UN054

REVISIONS

NUMBER	BY	DATE

0 1 2
 THIS BAR IS EQUAL TO 2"
 AT FULL SCALE (34X22).

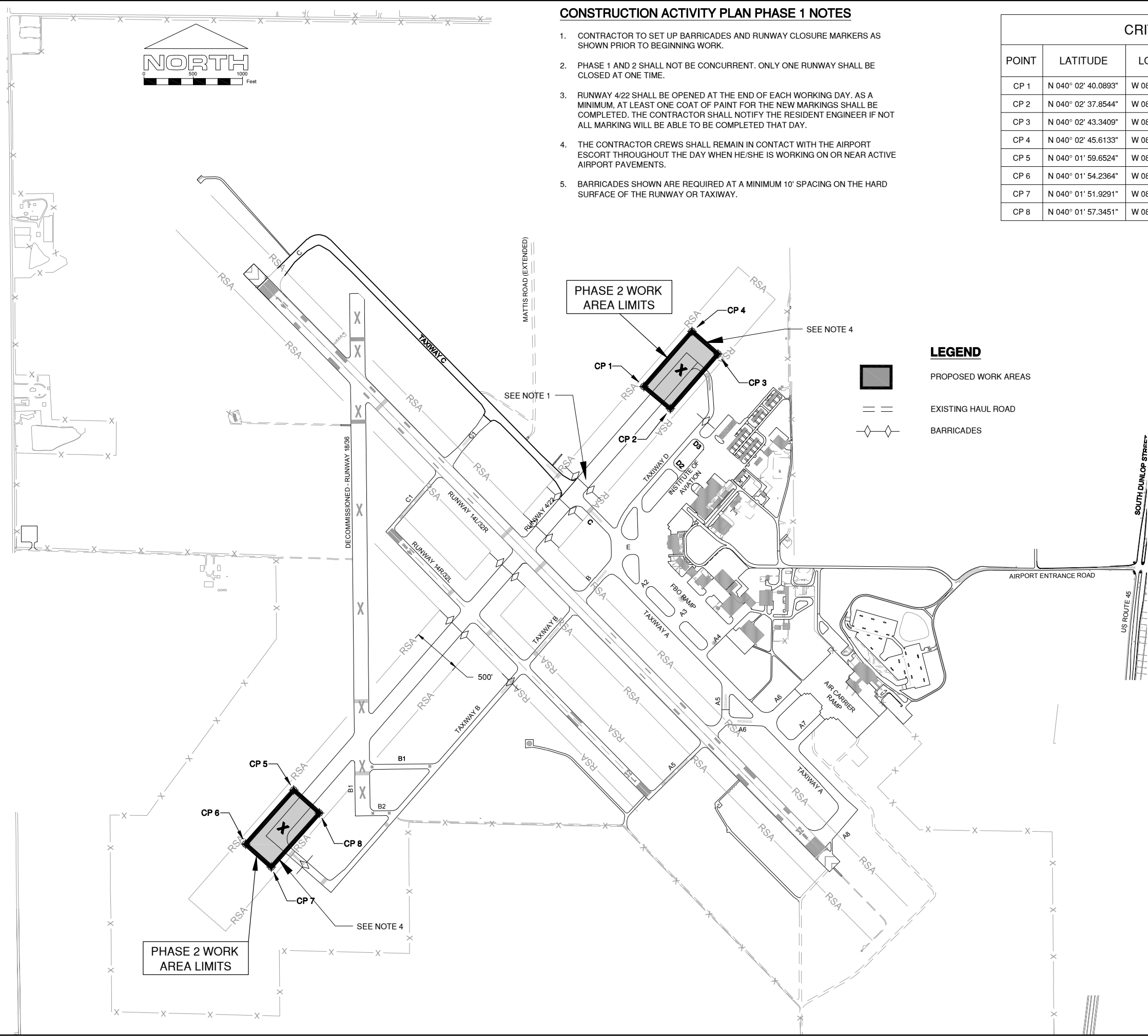

LEGEND

- PROPOSED WORK AREAS
- EXISTING HAUL ROAD
- BARRICADES

UNIVERSITY OF ILLINOIS
 WILLARD AIRPORT
 SAVOY, ILLINOIS

REMARK RUNWAY THRESHOLDS

CONSTRUCTION ACTIVITY PLAN - PHASE 2



DESIGN BY:	CBG
DRAWN BY:	ADD
CHECKED BY:	CET
APPROVED BY:	CET
DATE:	MAY 01, 2015
JOB No:	14059-03
IL. PROJ. NO. CMI-4408 AIP PROJ. NO. 3-17-0016-XX	
SHEET 07 OF 11 SHEETS	

K:\Champaign\1405903\Draw\Sheets

UN054

REVISIONS		
NUMBER	BY	DATE

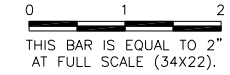

UNIVERSITY OF ILLINOIS
 WILLARD AIRPORT
 SAVOY, ILLINOIS
 REMARK RUNWAY THRESHOLDS
 REMOVAL AND REPLACEMENT
 PLAN RUNWAY 14L -32R

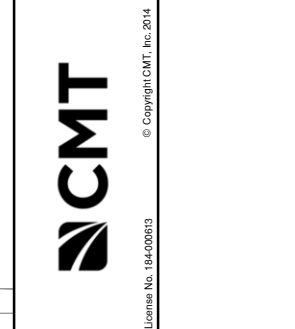

DESIGN BY:	CBG
DRAWN BY:	ADD
CHECKED BY:	CET
APPROVED BY:	CET
DATE:	MAY 01, 2015
JOB No:	14059-03
IL. PROJ. NO.	CMI-4408
AIP PROJ. NO.	3-17-0016-XX
SHEET	08 OF 11 SHEETS

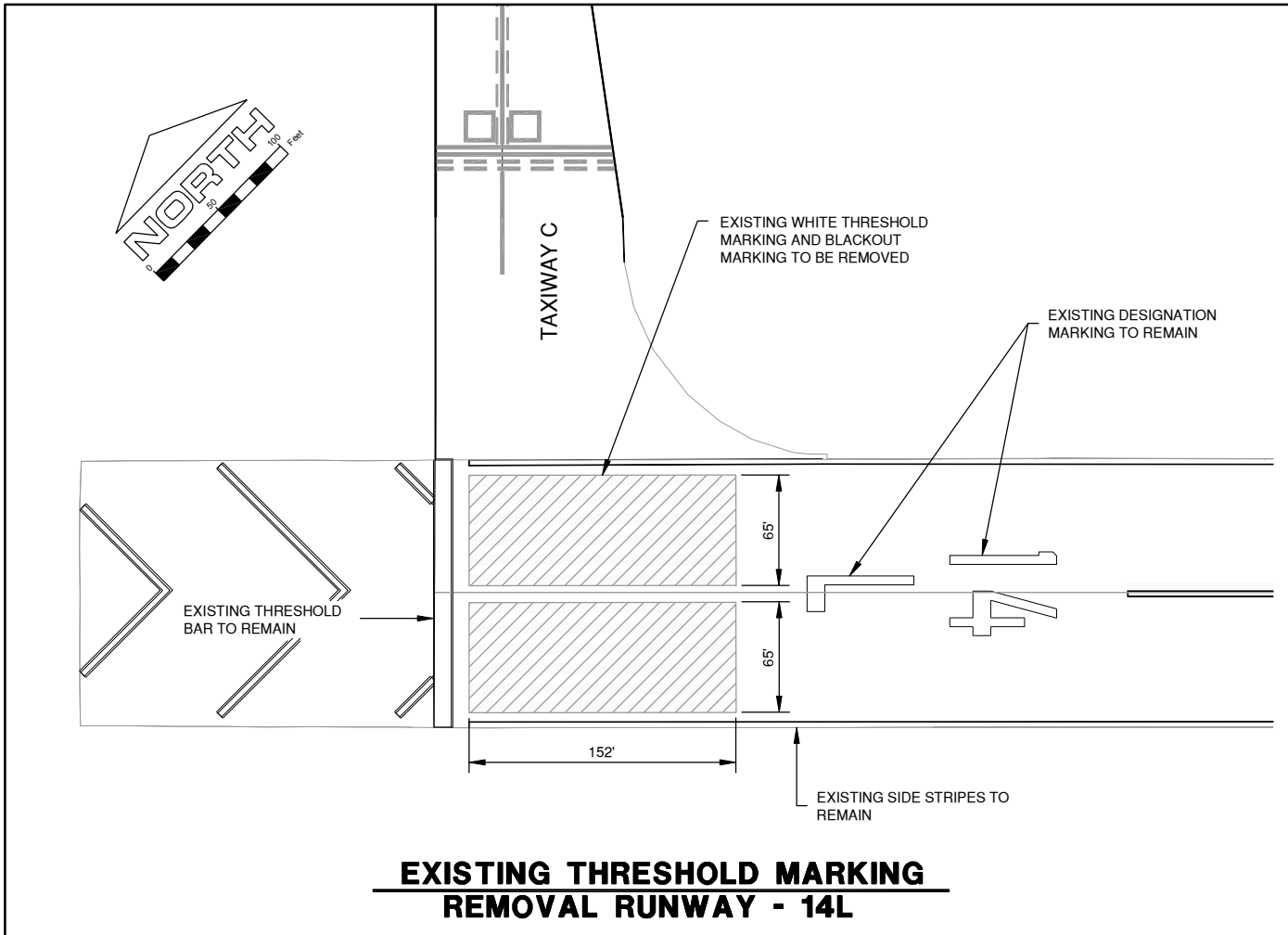

**EXISTING THRESHOLD MARKING
 REMOVAL RUNWAY - 14L**

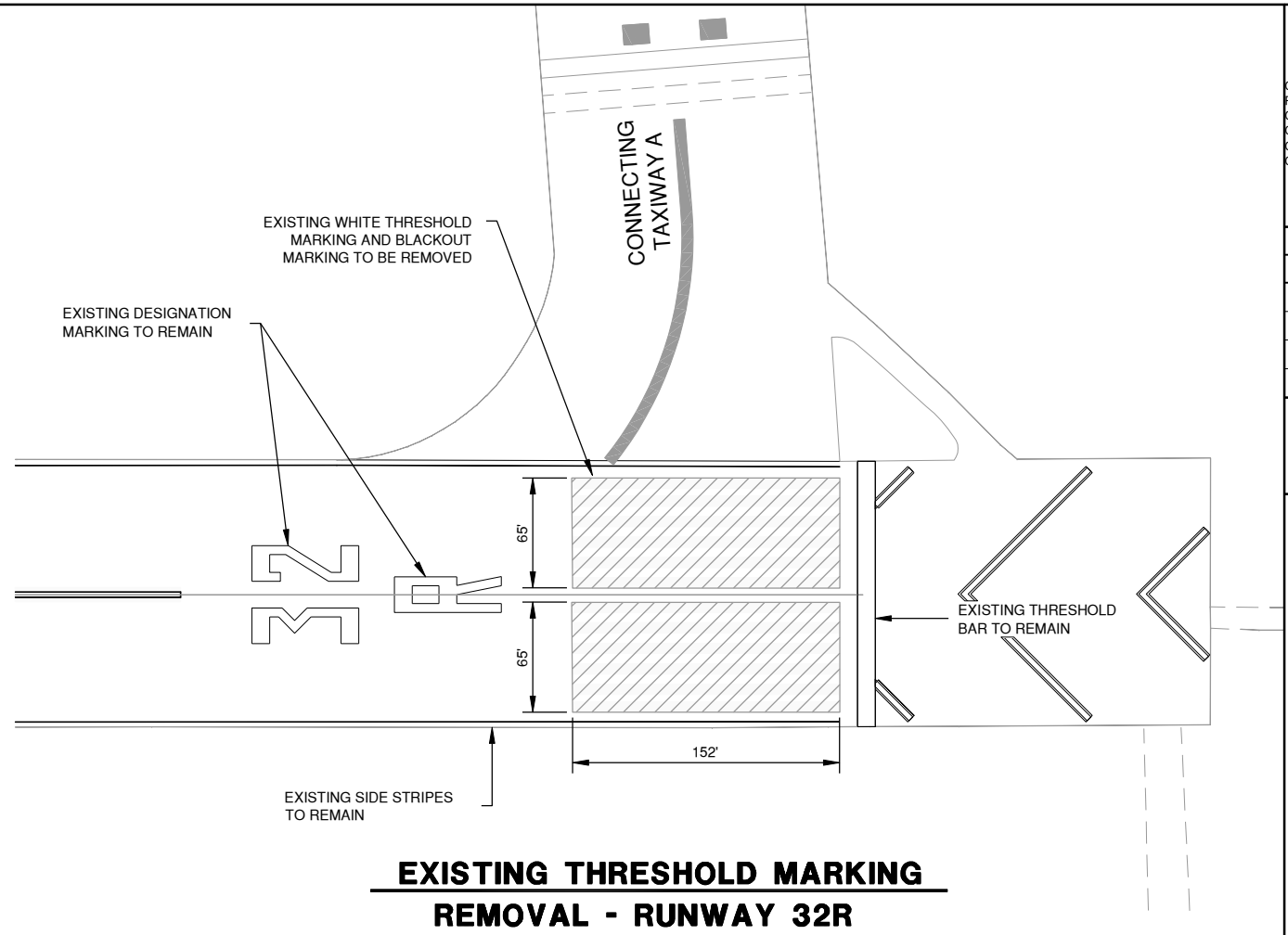

**EXISTING THRESHOLD MARKING
 REMOVAL - RUNWAY 32R**

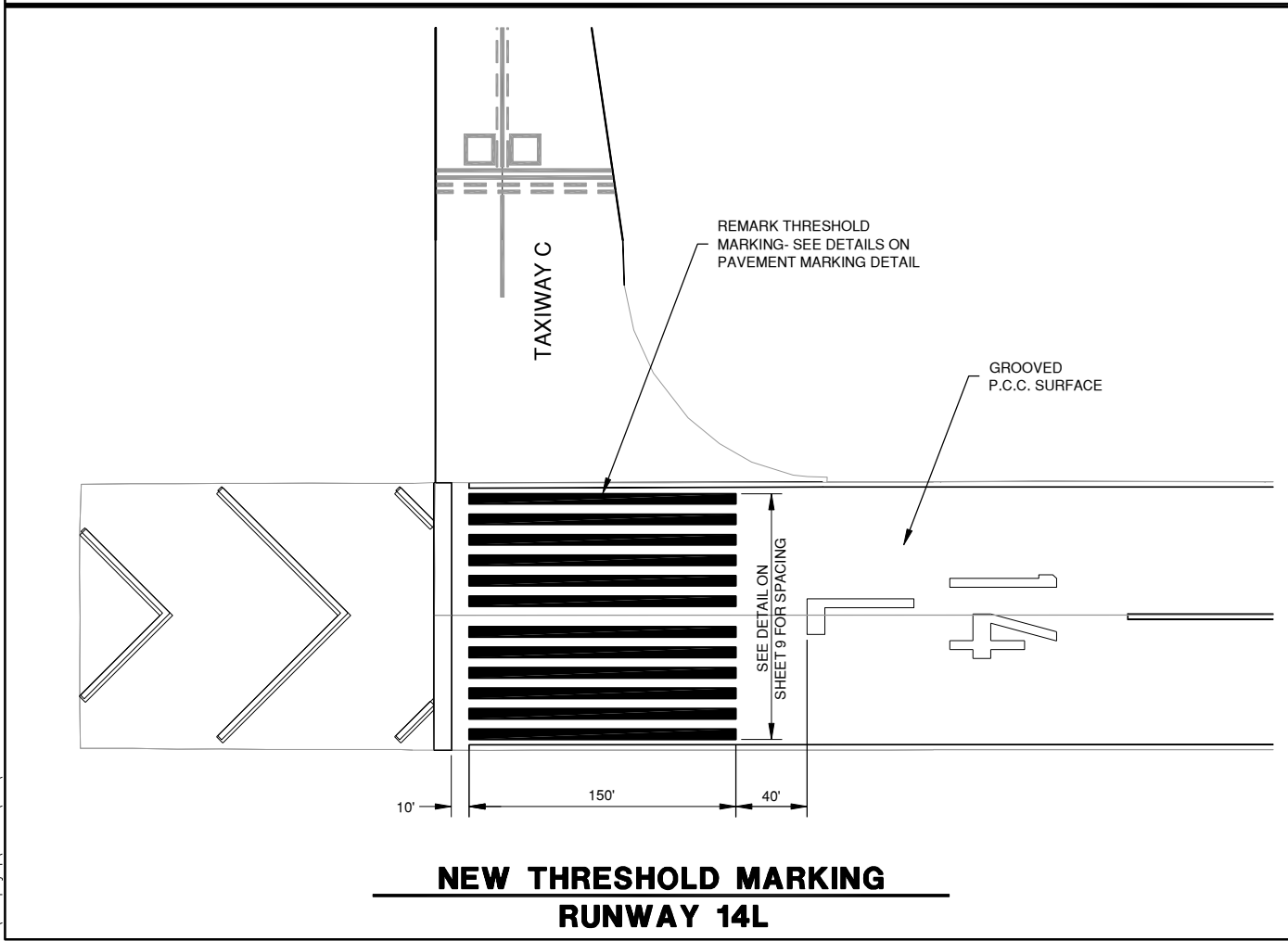

**NEW THRESHOLD MARKING
 RUNWAY 14L**

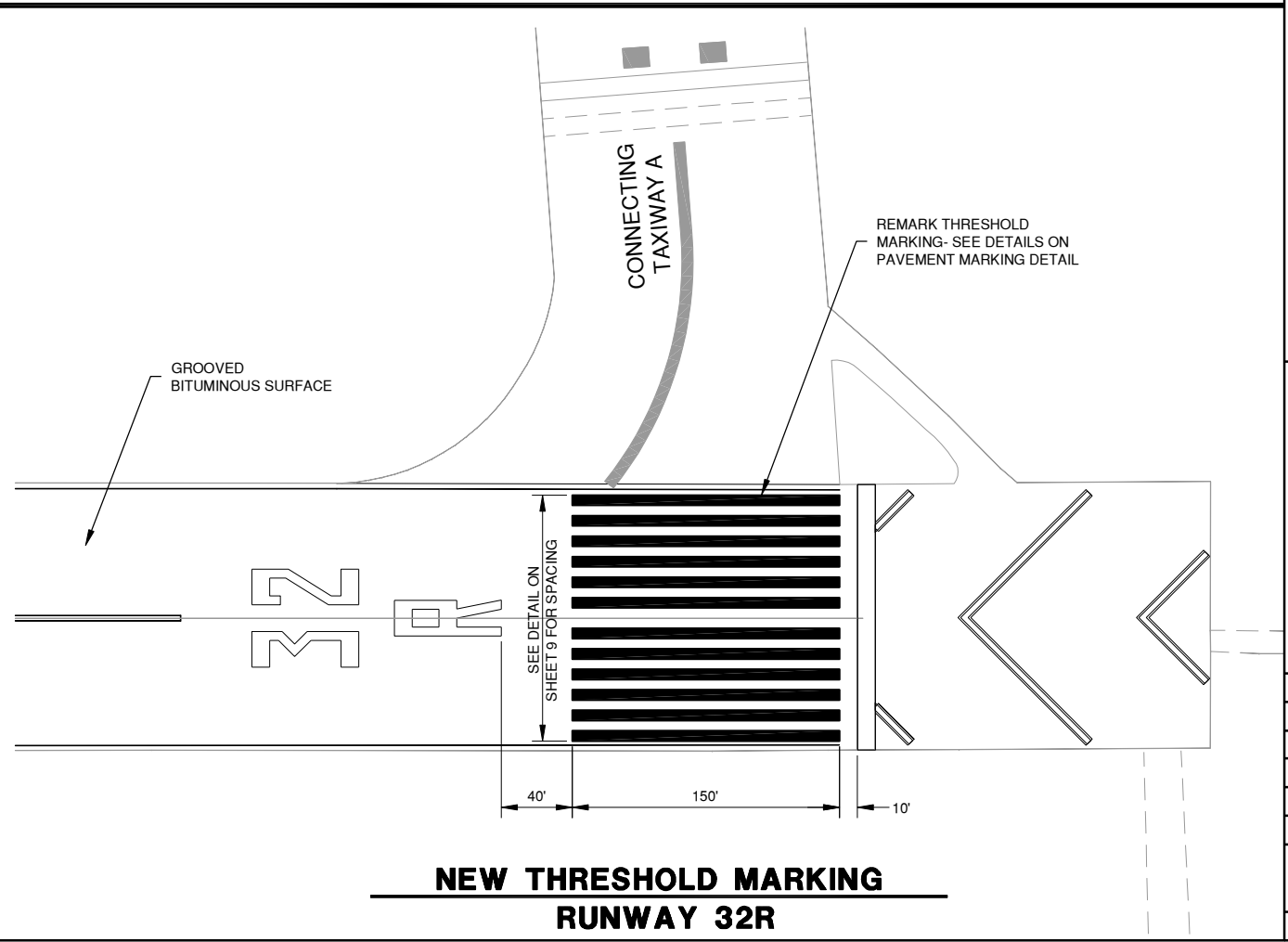

**NEW THRESHOLD MARKING
 RUNWAY 32R**

K:\Champaign\1405903\Draw\Sheets

UN054

REVISIONS		
NUMBER	BY	DATE

0 1 2
 THIS BAR IS EQUAL TO 2"
 AT FULL SCALE (34X22).

UNIVERSITY OF ILLINOIS
 WILLARD AIRPORT
 SAVOY, ILLINOIS

REMARK RUNWAY THRESHOLDS

REMOVAL AND REPLACEMENT PLAN RUNWAY 4-22



© Copyright CMT, Inc. 2014
 License No. 184-006013

DESIGN BY:	CBG
DRAWN BY:	ADD
CHECKED BY:	CET
APPROVED BY:	CET
DATE:	MAY 01, 2015
JOB No:	14059-03

IL. PROJ. NO. CMI-4408
 AIP PROJ. NO. 3-17-0016-XX

SHEET 09 OF 11 SHEETS

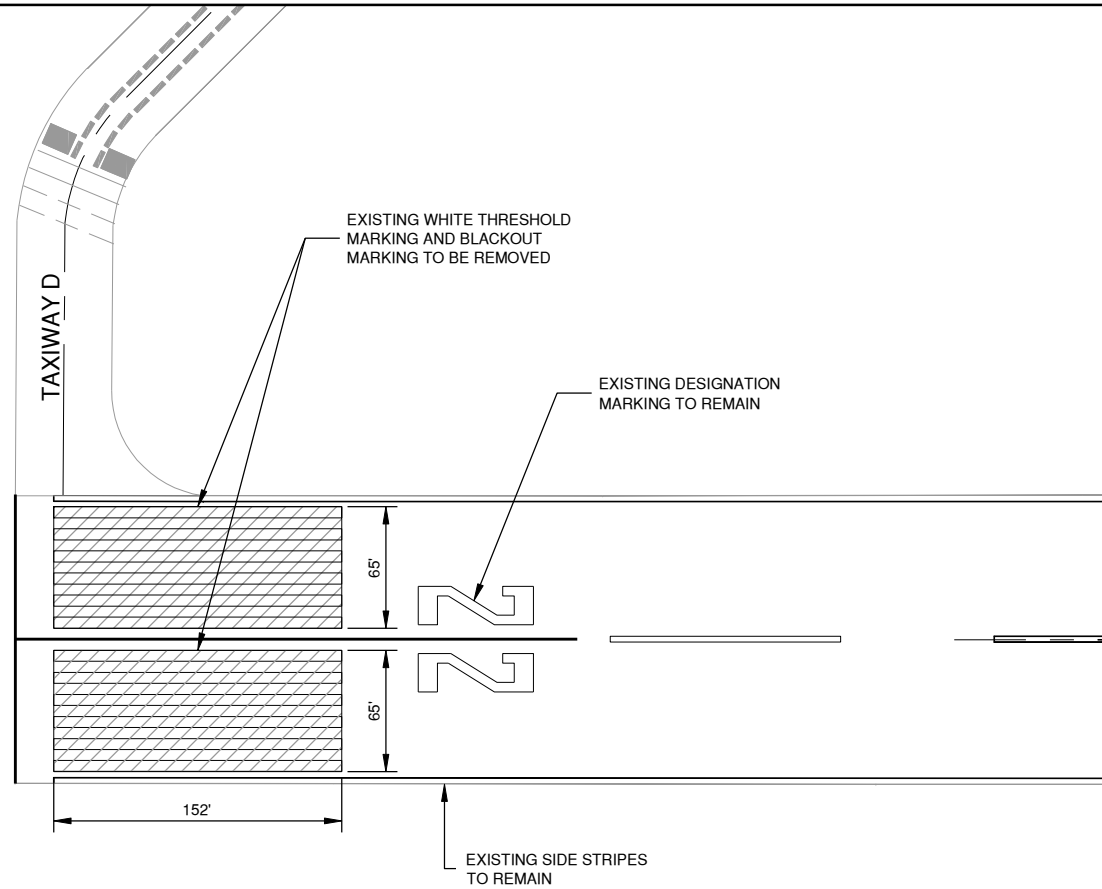
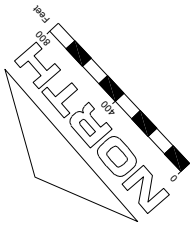

**EXISTING THRESHOLD MARKING
 REMOVAL - RUNWAY 22**

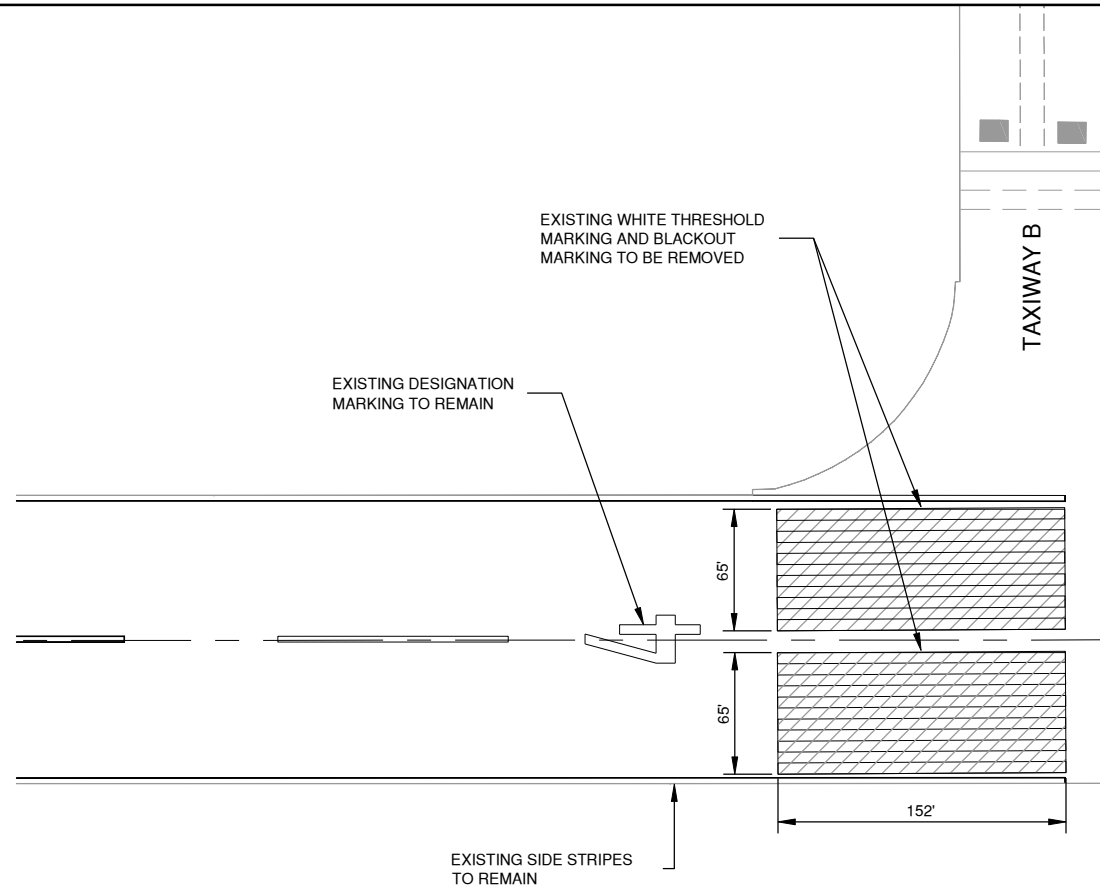

**EXISTING THRESHOLD MARKING
 REMOVAL - RUNWAY 4**

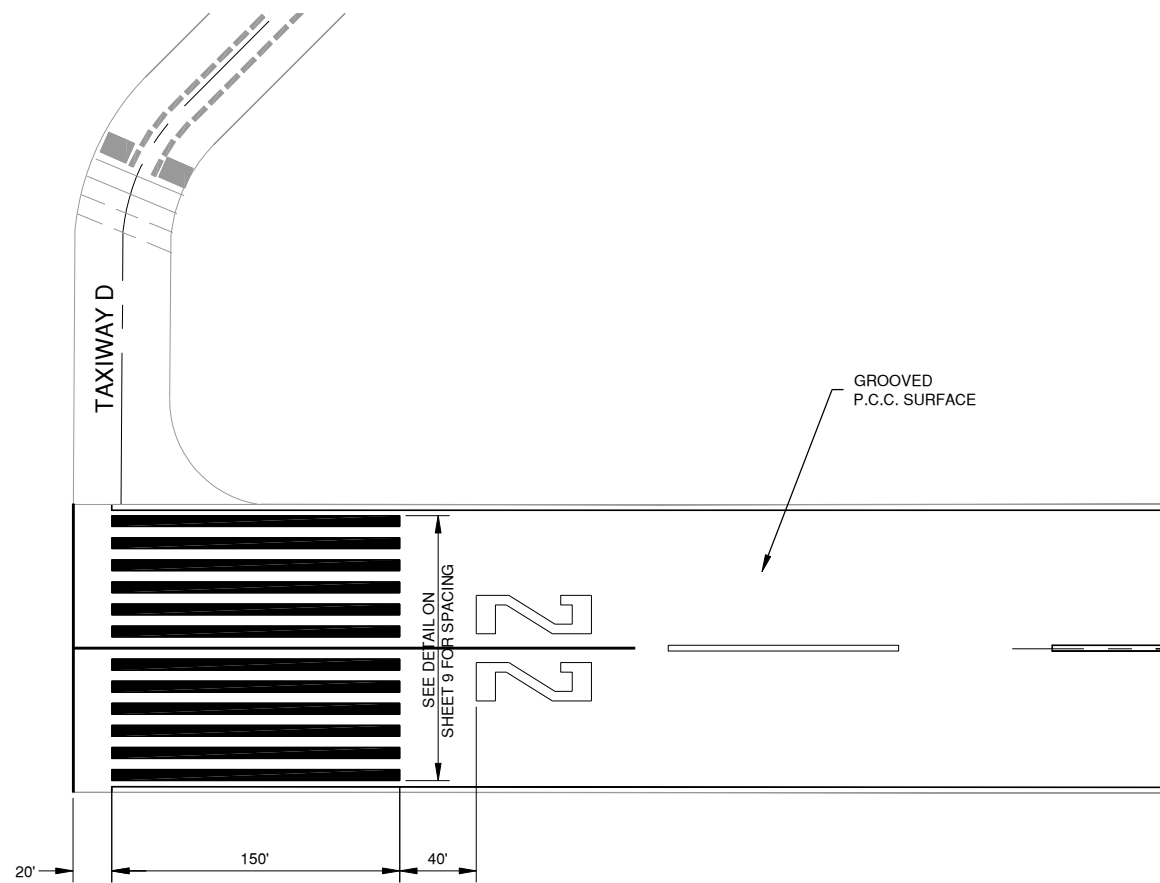

**NEW THRESHOLD MARKING
 RUNWAY 22**

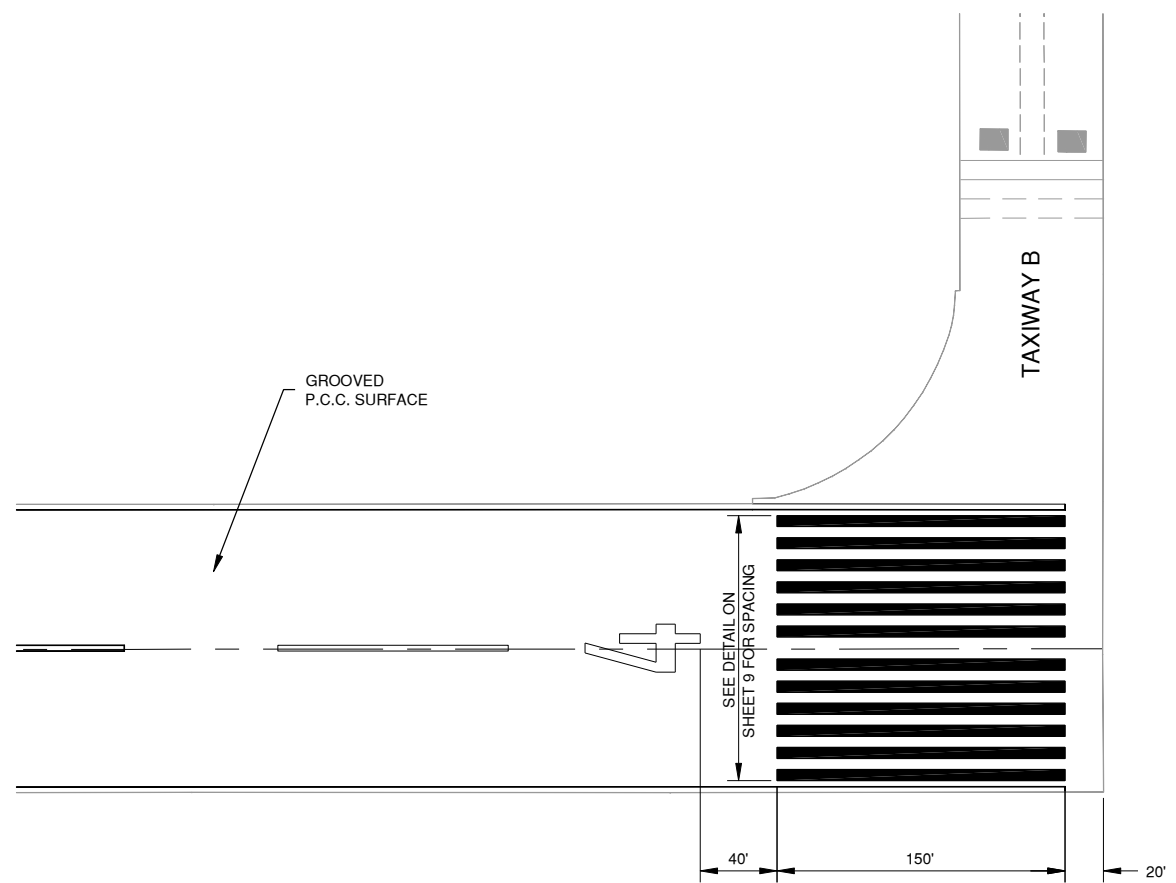

**NEW THRESHOLD MARKING
 RUNWAY 4**

UN054

REVISIONS

NUMBER	BY	DATE

0 1 2
 THIS BAR IS EQUAL TO 2"
 AT FULL SCALE (34x22).

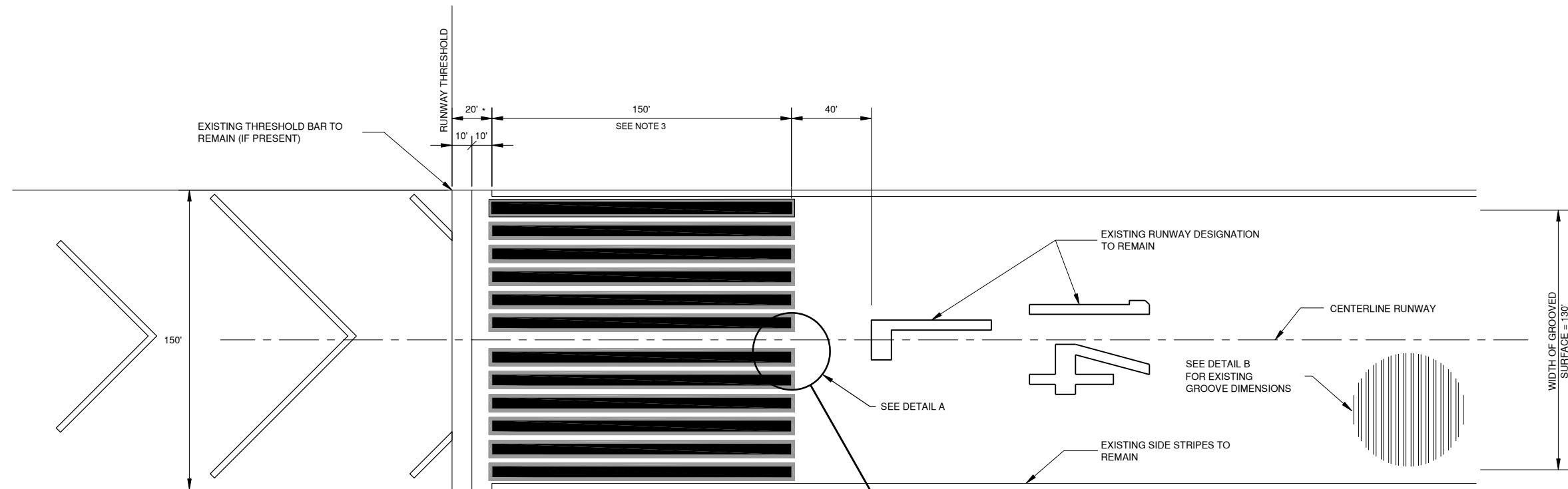

NEW THRESHOLD MARKINGS

N.T.S.

NOTES:

1. ALL NEW MARKINGS WILL HAVE A BLACK BORDER AS SHOWN.
2. THE PAVEMENT MUST BE CLEANED TO THE RESIDENT ENGINEER'S SATISFACTION PRIOR TO BEGINNING NEW MARKING. ALL RUNWAYS HAVE GROOVED SURFACES.
3. DIMENSIONS ARE SHOWN TO THE EDGE OF THE WHITE MARKINGS. BLACK BORDER IS TO THE OUTSIDE OF THE DIMENSIONS SHOWN.
4. PAVEMENT MARKING REMOVAL SHALL REMOVE PAINT WITHIN THE GROOVES OF THE EXISTING PAVEMENT.

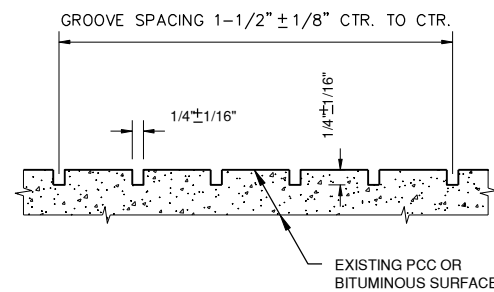

B EXISTING GROOVING DETAILS

N.T.S.

NOTES:

1. GROOVES EXTEND OUTWARD 65' FROM THE RUNWAY CENTERLINE.
2. GROOVES AT THRESHOLD 22 NOT DRAINING PROPERLY DUE TO SEALANT IN GROOVES.

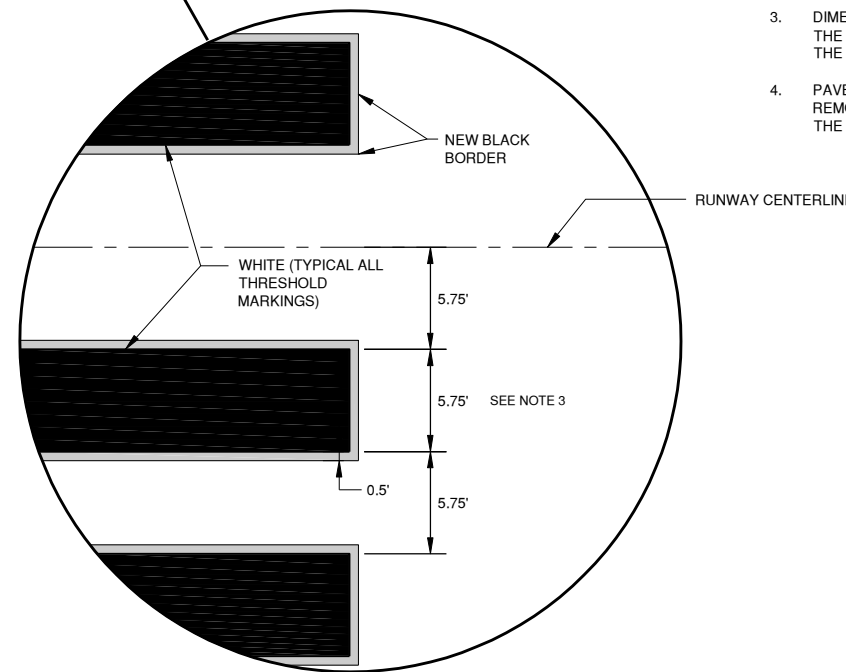

A TRANSVERSE SPACING

N.T.S.

UNIVERSITY OF ILLINOIS
 WILLARD AIRPORT
 SAVOY, ILLINOIS

REMARK RUNWAY THRESHOLDS

PAVEMENT MARKING DETAILS



© Copyright CMT, Inc. 2014
 License No. 184-000613

DESIGN BY:	CBG
DRAWN BY:	ADD
CHECKED BY:	CET
APPROVED BY:	CET
DATE:	MAY 01, 2015
JOB No:	14059-03
IL PROJ. NO.	CMI-4408
AIP PROJ. NO.	3-17-0016-XX
SHEET	10 OF 11 SHEETS

UN054

REVISIONS		
NUMBER	BY	DATE

0 1 2
 THIS BAR IS EQUAL TO 2"
 AT FULL SCALE (34X22).

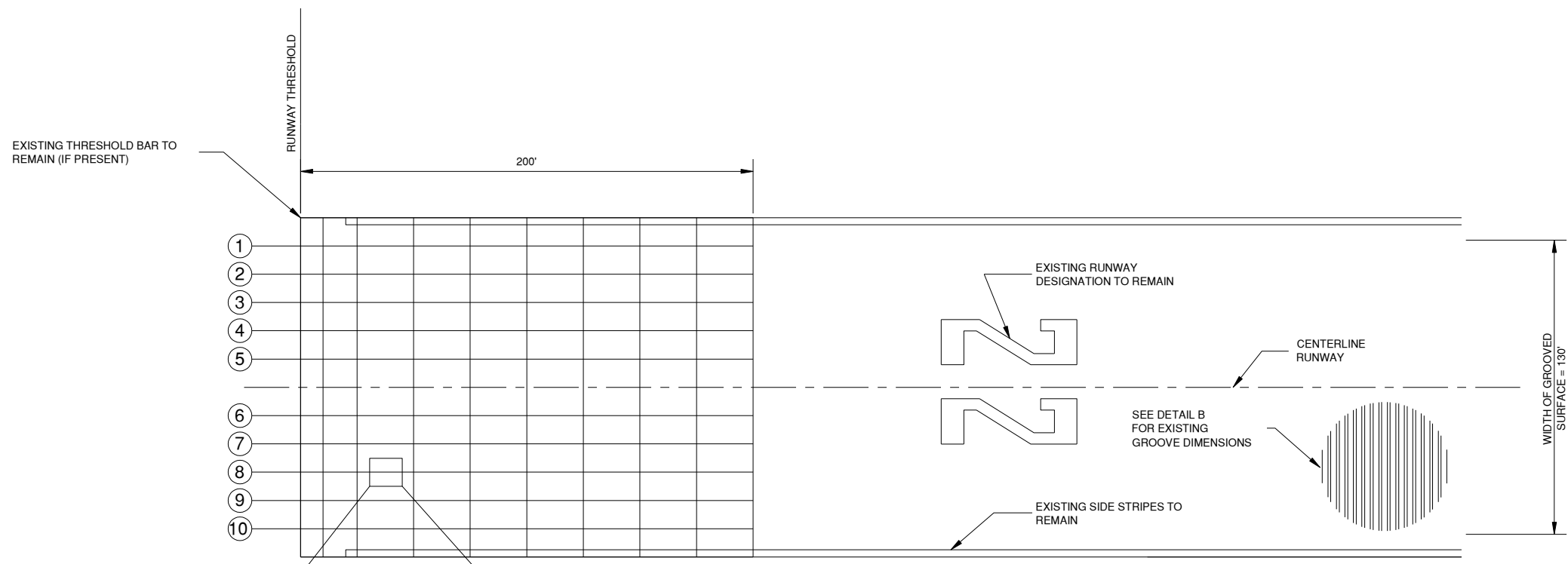

RUNWAY 22 JOINT LAYOUT

N.T.S.

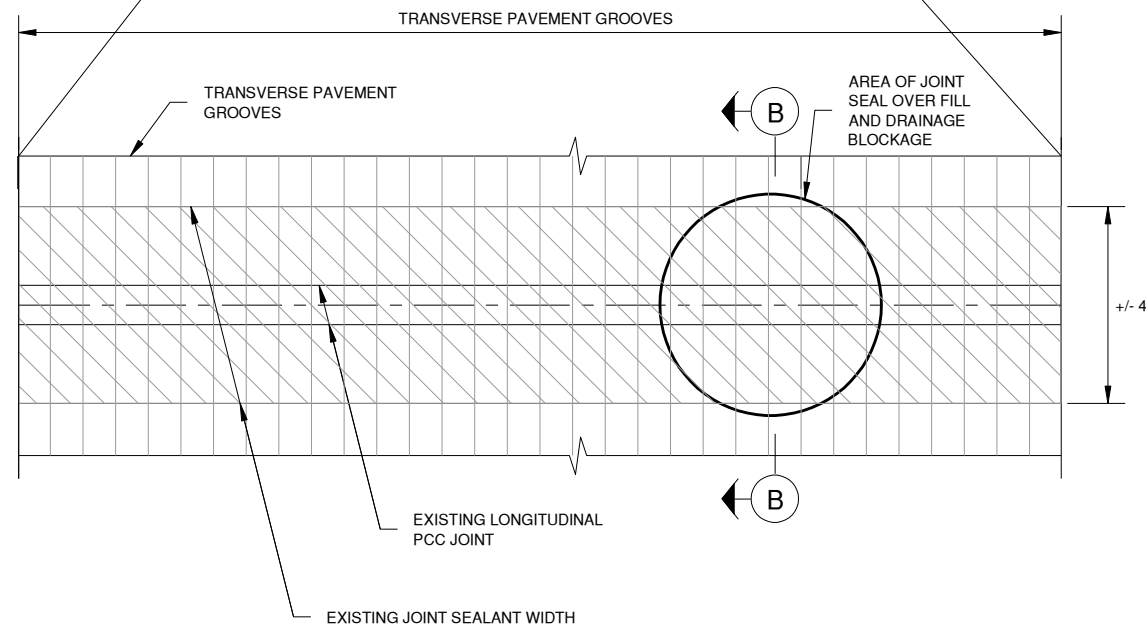

EXISTING GROOVING DETAIL

N.T.S.

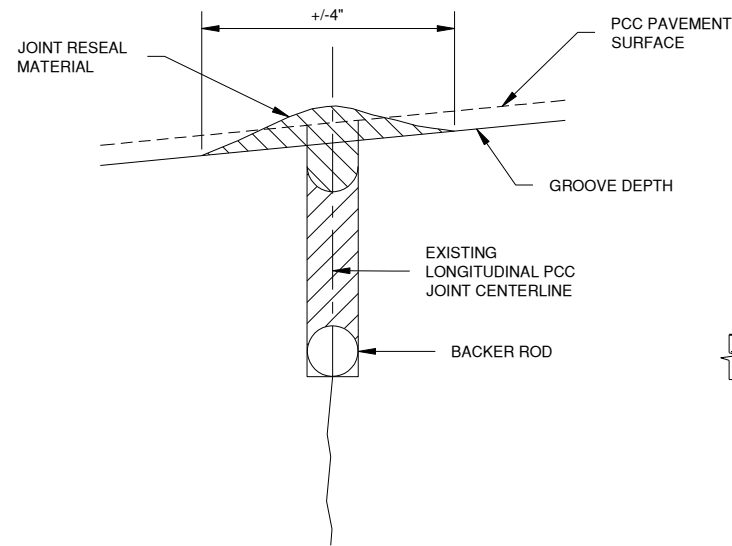

EXISTING GROOVING SECTION DETAIL

N.T.S.

NOTES:

- CONTRACTOR SHALL REMOVE JOINT SEAL MATERIAL FROM GROOVES USING METHODS THAT DO NOT DAMAGE THE EXISTING CONCRETE PAVEMENT.
- PAYMENT FOR REMOVAL OF MATERIAL SHALL BE MADE UNDER AR501545-CLEAN PCC PAVEMENT GROOVING PER LINEAL FOOT OF LONGITUDINAL JOINT.
- CLEANING THE GROOVES SHALL ALSO INCLUDE THE REMOVAL OF EXISTING JOINT SEALANT/BACKER ROD AND REPLACING IT WITH NEW JOINT SEALANT/BACKER ROD.

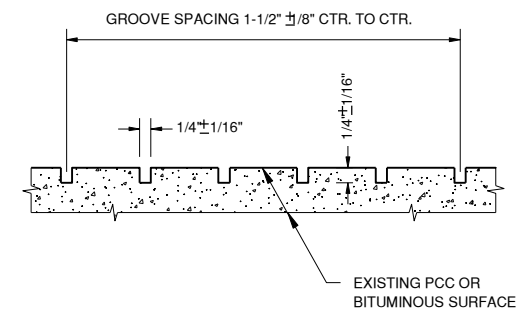

EXISTING GROOVING DETAILS

N.T.S.

NOTES:

- GROOVES EXTEND OUTWARD 65' FROM THE RUNWAY CENTERLINE.
- GROOVES AT THRESHOLD 22 NOT DRAINING PROPERLY DUE TO SEALANT IN GROOVES.

UNIVERSITY OF ILLINOIS
 WILLARD AIRPORT
 SAVOY, ILLINOIS

REMARK RUNWAY THRESHOLDS

PAVEMENT GROOVING CLEANING MARKING DETAILS



© Copyright CMT, Inc. 2014
 License No. 184-000613

DESIGN BY:	CBG
DRAWN BY:	ADD
CHECKED BY:	CET
APPROVED BY:	CET
DATE:	MAY 01, 2015
JOB No:	14059-03
IL PROJ. NO.	CMI-4408
AIP PROJ. NO.	3-17-0016-XX
SHEET	11 OF 11 SHEETS