

F.A.I. RTE.	SECTION	COUNTY	TOTAL SHEETS	SHEET NO.
55	*	WILL	608	413
STA.		TO STA.		
FED. ROAD DIST. NO. 1		ILLINOIS FED. AID PROJECT		
* (26, 26HB-18114) R-2		CONTRACT NO. 60363		

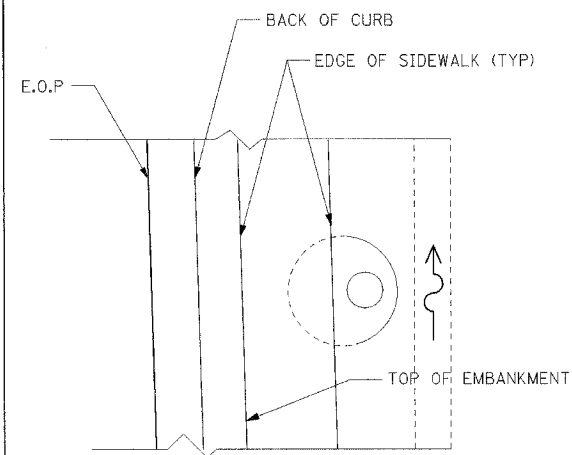

**PLAN VIEW**  
**MANHOLE WITH FLAT SLAB TOP IN PARKWAY**

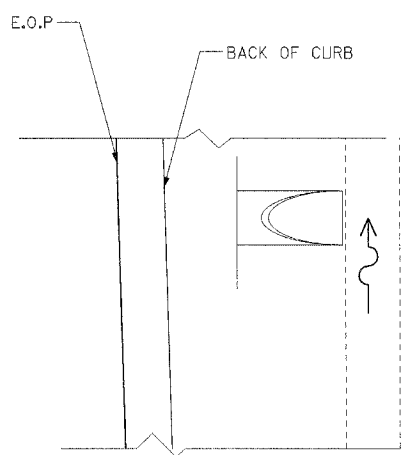

**PLAN VIEW**  
**FLARED END SECTION**

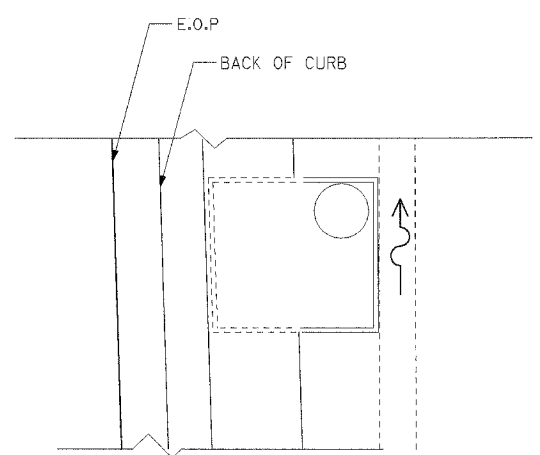

**PLAN VIEW**  
**JUNCTION CHAMBER**

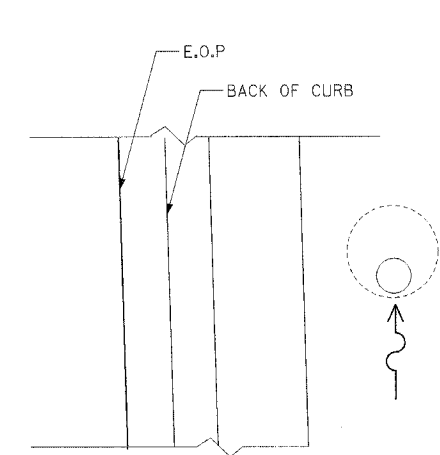

**PLAN VIEW**  
**CATCH BASIN IN DITCH**

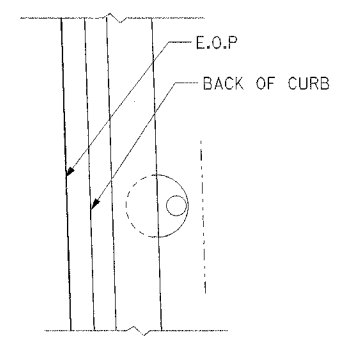

**PLAN VIEW**  
**MANHOLE WITH CONE SECTION IN PARKWAY**

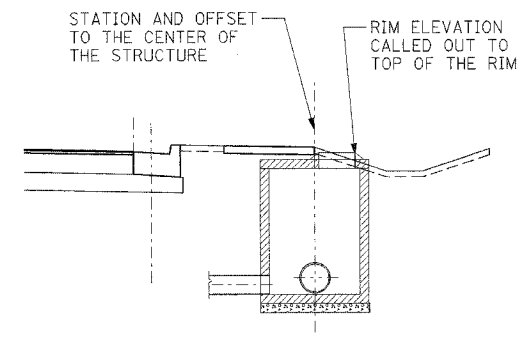

**SECTION**  
**MANHOLE WITH FLAT SLAB TOP IN PARKWAY**

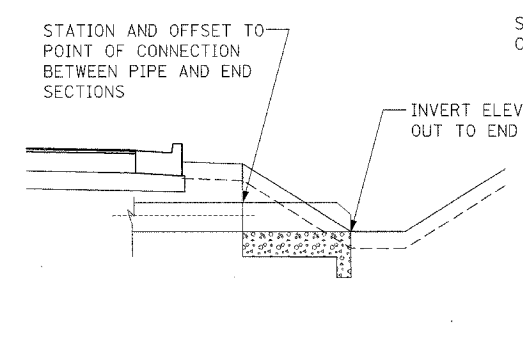

**ELEVATION**  
**FLARED END SECTION**

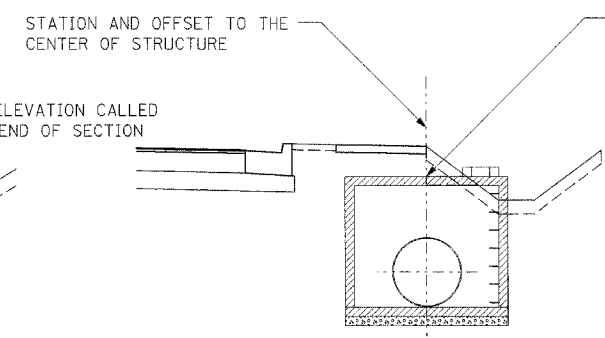

**ELEVATION**  
**JUNCTION CHAMBER**

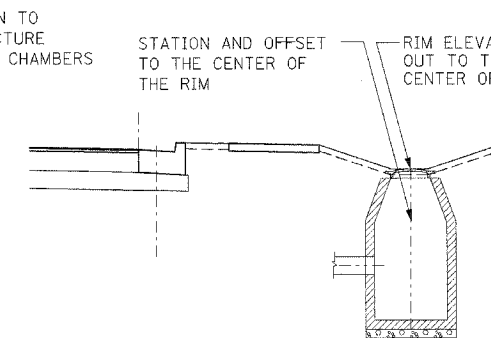

**ELEVATION**  
**CATCH BASIN IN DITCH**

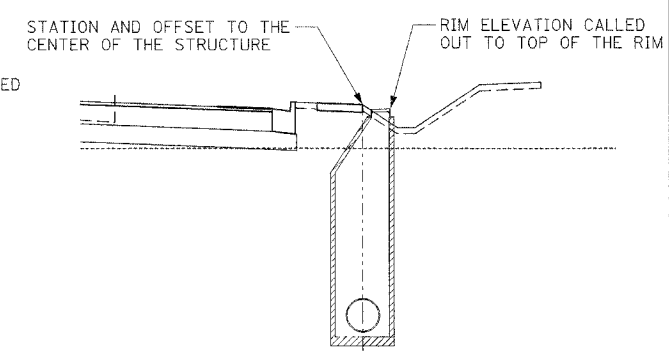

**SECTION**  
**MANHOLE WITH CONE SECTION IN PARKWAY**

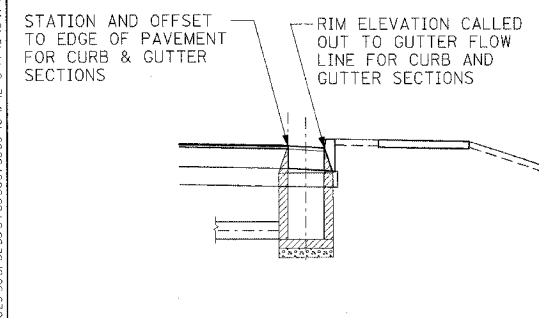

**ELEVATION**  
**INLET WITH CURB AND GUTTER**

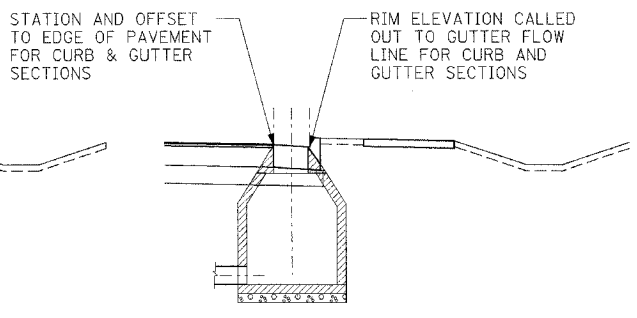

**ELEVATION**  
**MANHOLE WITH CURB AND GUTTER**

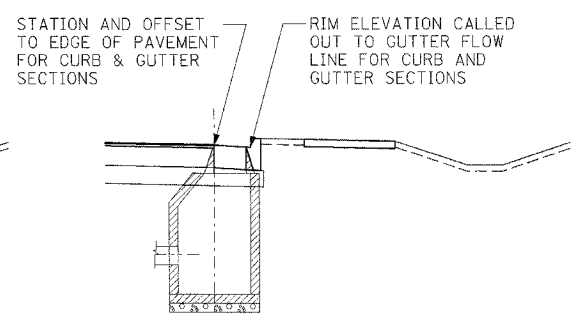

**ELEVATION**  
**CATCH BASIN WITH CURB AND GUTTER**

\*ATTORNEY IN CHARGE... 3-12-2008... 12 13 14 15 16 17 18 19 20 21 22 23 24 25 26 27 28 29 30 31 32 33 34 35 36 37 38 39 40 41 42 43 44 45 46 47 48 49 50 51 52 53 54 55 56 57 58 59 60 61 62 63

REVISIONS	
NAME	DATE

ILLINOIS DEPARTMENT OF TRANSPORTATION  
 FAI 55 AT FAP 338 ILLINOIS ROUTE 59  
 SECTION: (26, 26HB-18114) R-2

**DRAINAGE DETAILS IV**  
**DRAINAGE STRUCTURE PLACEMENT**

SCALE: N.T.S. DRAWN BY: MRK  
 DATE: 03/14/08 CHECKED BY: TKL

**TENG**  
 TENG & ASSOCIATES, INC.  
 ENGINEERS ARCHITECTS PLANNERS  
 300 N. MICHIGAN AVE. CHICAGO, IL 60610  
 TELEPHONE 312.955.9999