

**EXISTING TYPICAL SECTION**

STA. 59+27 TO STA. 61+07  
 STA. 65+70 TO STA. 67+30  
 STA. 86+32 TO STA. 91+17

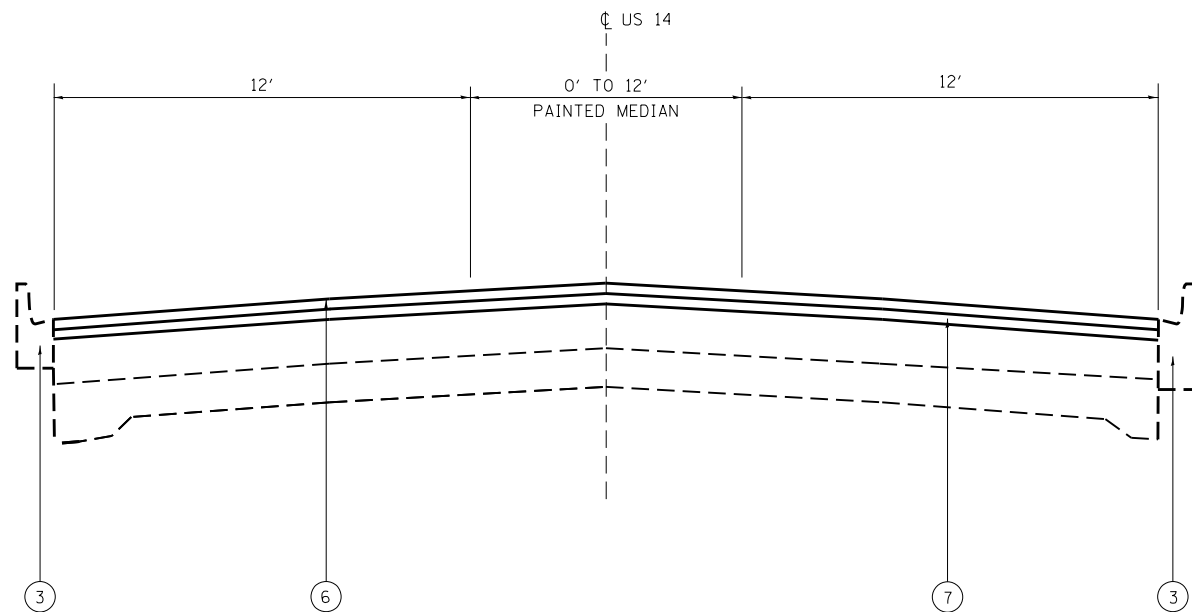

**PROPOSED TYPICAL SECTION**

STA. 59+27 TO STA. 61+07  
 STA. 65+70 TO STA. 67+30  
 STA. 86+32 TO STA. 91+17

**LEGEND**

- ① EXIST. P.C.C. PAVEMENT (9-7-9)
- ② EXISTING HOT-MIX ASPHALT PAVEMENT AFTER MILLING, ± 10 3/4"
- ③ EXISTING COMBINATION CONCRETE CURB & GUTTER, TYPE B 6.24
- ④ EXIST. HOT-MIX ASPHALT SHOULDER
- ⑤ PROPOSED HOT-MIX ASPHALT SURFACE REMOVAL, 2 1/2"
- ⑥ PROPOSED POLYMERIZED HOT-MIX ASPHALT SURFACE COURSE, MIX "F", N90, 1 3/4"
- ⑦ PROPOSED POLYMERIZED LEVELING BINDER (MACHINE METHOD), IL-4.75, N50, 3/4"
- ⑧ PROPOSED HOT-MIX ASPHALT SURFACE COURSE, MIX "D", N70", 1 3/4" ( SHOULDERS ONLY)
- ⑨ PROPOSED AGGREGATE WEDGE SHOULDER, TYPE B

FILE NAME =	USER NAME = rozeqem	DESIGNED -	REVISED -	<b>STATE OF ILLINOIS DEPARTMENT OF TRANSPORTATION</b>	<b>US ROUTE 14 (DIVISION ST.) FROM IL 23 TO BRINK ST. EXISTING &amp; PROPOSED TYPICAL SECTIONS</b>	F.A.P. RTE.	SECTION	COUNTY	TOTAL SHEETS	SHEET NO.	
Default	Plot SCALE = 100.0000' / in.	DRAWN -	REVISED -			324	29R-RS-3	MCHENRY	25	6	
	PLOT DATE = 4/17/2014	CHECKED -	REVISED -			<b>CONTRACT NO. 60V13</b>					
		DATE -	REVISED -			SCALE:	SHEET 2 OF 3 SHEETS	STA.	TO STA.	ILLINOIS FED. AID PROJECT	