

EAST QUARTER CORNER  
SECTION 12 T30N R3E

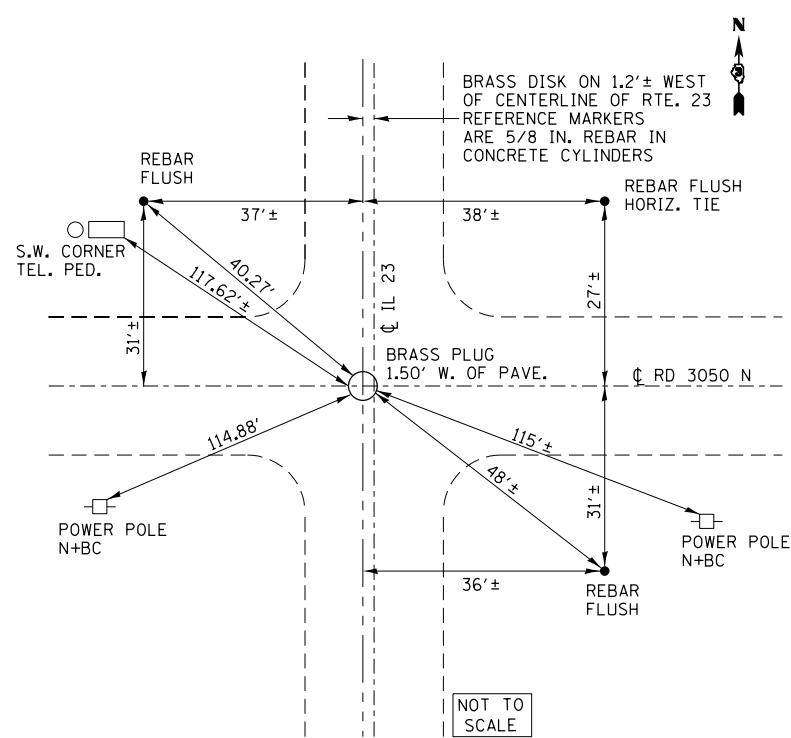

WEST QUARTER CORNER  
SECTION 13 T30N R3E

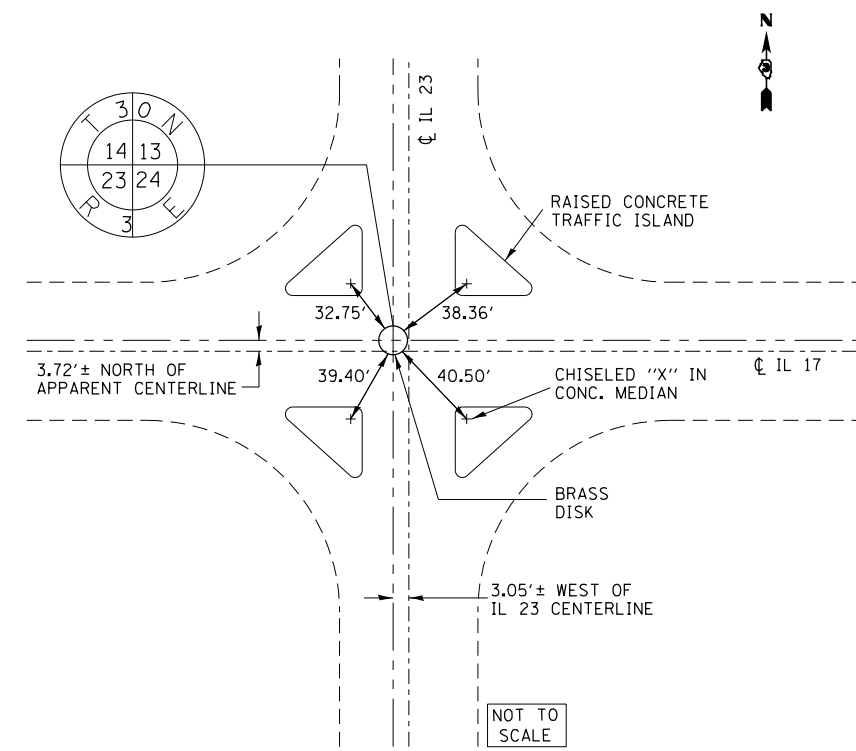

SOUTHEAST CORNER  
SECTION 14 T30N R3E

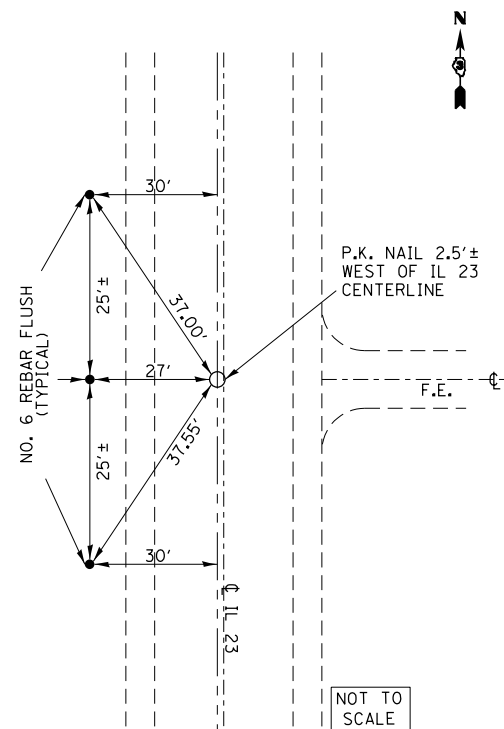

WEST QUARTER CORNER  
SECTION 36 T30N R3E

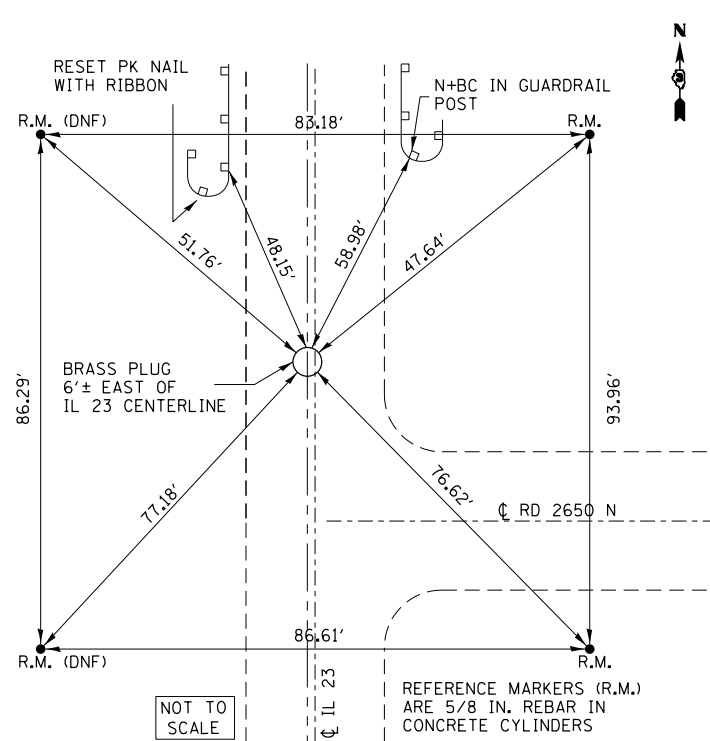

EAST QUARTER CORNER  
SECTION 2 T29N R3E

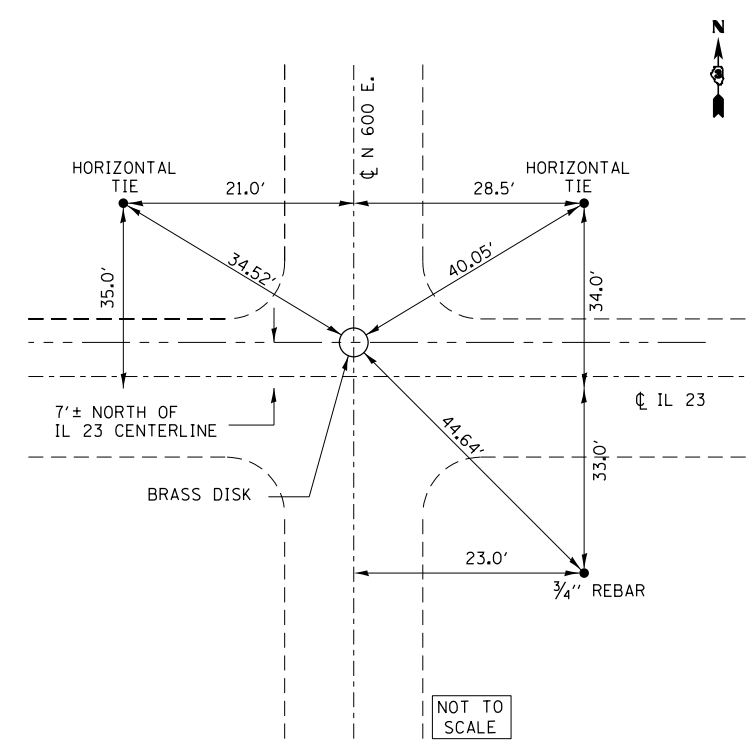

EAST QUARTER CORNER  
SECTION 12 T29N R3E

FILE NAME =	USER NAME = Schwankerg	DESIGNED -	REVISED -
c:\pw\work\p\midot\schwankerg\d0287863\066885-sht-details.dgn		DRAWN -	REVISED -
PLOT SCALE = 100.0000' / in.		CHECKED -	REVISED -
PLOT DATE = 6/6/2014		DATE -	REVISED -

STATE OF ILLINOIS  
DEPARTMENT OF TRANSPORTATION

PERMANENT SURVEY MARKERS  
TIE POINTS

SCALE:	SHEET NO.	OF SHEETS	STA.	TO STA.
--------	-----------	-----------	------	---------

F.A.P. RTE.	SECTION	COUNTY	TOTAL SHEETS	SHEET NO.
68	(101,102)RS-3	LIVINGSTON	22	19
CONTRACT NO. 66B85			ILLINOIS FED. AID PROJECT	