

SECTION P-P

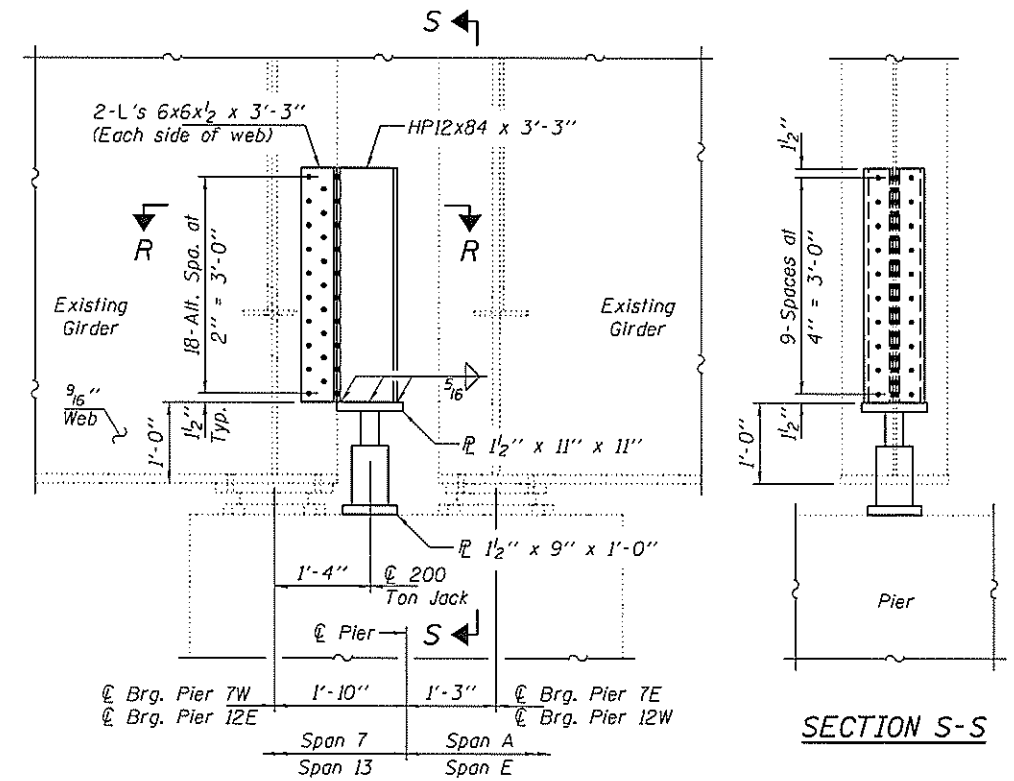

JACKING DETAIL FOR BEARING REPLACEMENT AT PIERS 7 & 12

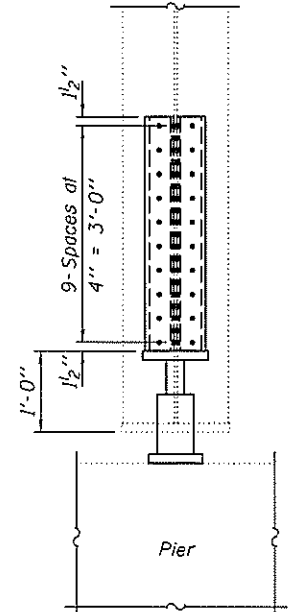

SECTION S-S

ITEM 6 REPAIR DETAILS

\* Anchor bolts shall be ASTM F1554 all-thread (or an Engineer-approved alternate material) of the grade(s) and diameter(s) specified. ASTM A307 Grade C anchor bolts may be used in lieu of ASTM F1554 Grade 36 (Fy=36ksi). The corresponding specified grade of AASHTO M314 anchor bolts may be used in lieu of ASTM F1554.  
 Drilled and set anchor bolts shall be installed according to Article 521.06 of the Standard Specifications.

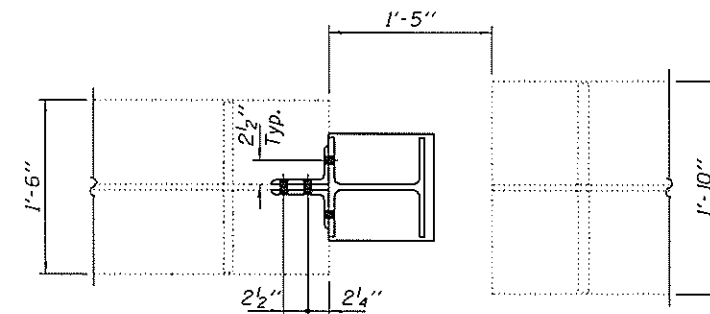

SECTION R-R

DESIGNED <i>ATH</i>	EXAMINED <i>Timothy A. Anzani</i>	DATE <i>JUNE 24, 2014</i>	STATE OF ILLINOIS DEPARTMENT OF TRANSPORTATION	REPAIR DETAILS SN 001-0068	F.A. RTE.	SECTION	COUNTY	TOTAL SHEETS	SHEET NO.
CHECKED <i>GGE</i>	ACTING ENGINEER OF STRUCTURAL SERVICES	REVISOR			63	(12B)JR, I-7	ADAMS	31	27
DRAWN <i>Kyle M. Steffen</i>	ACTING ENGINEER OF BRIDGES AND STRUCTURES	REVISOR			CONTRACT NO. T2G80				
CHECKED <i>ATH GGE</i>					ILLINOIS FED. AID PROJECT				