

**STAGE I REMOVAL**  
(Pier 1 shown, looking East)

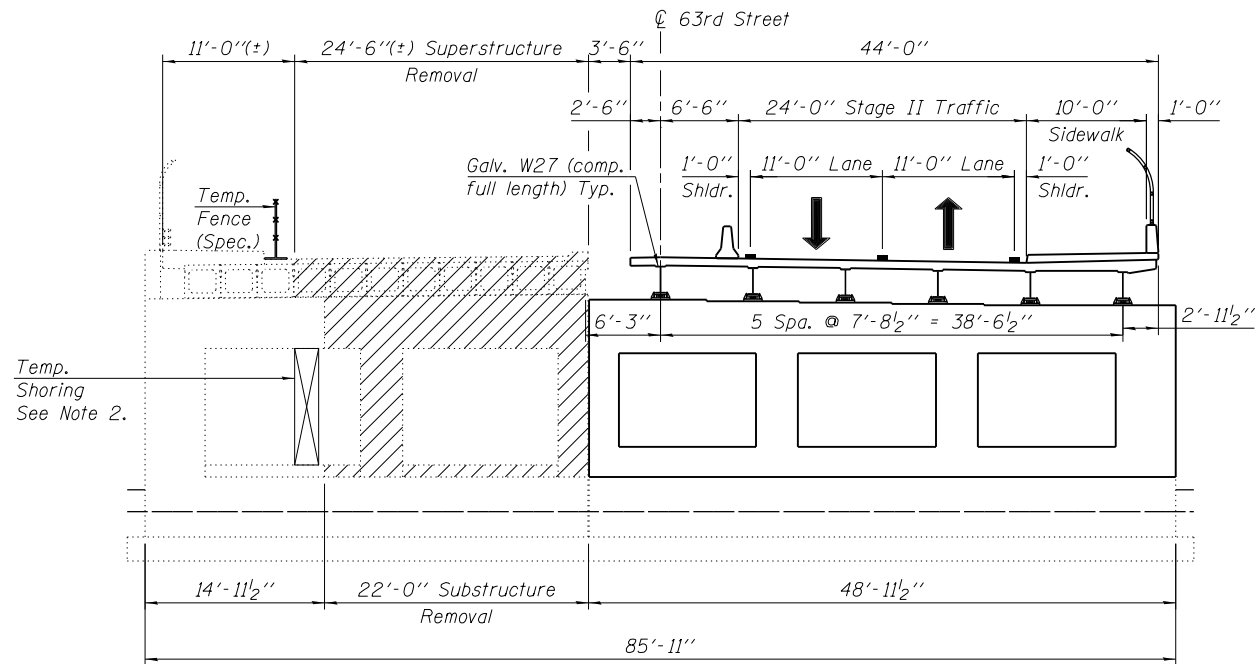

**STAGE II REMOVAL**  
(Pier 1 shown, looking East)

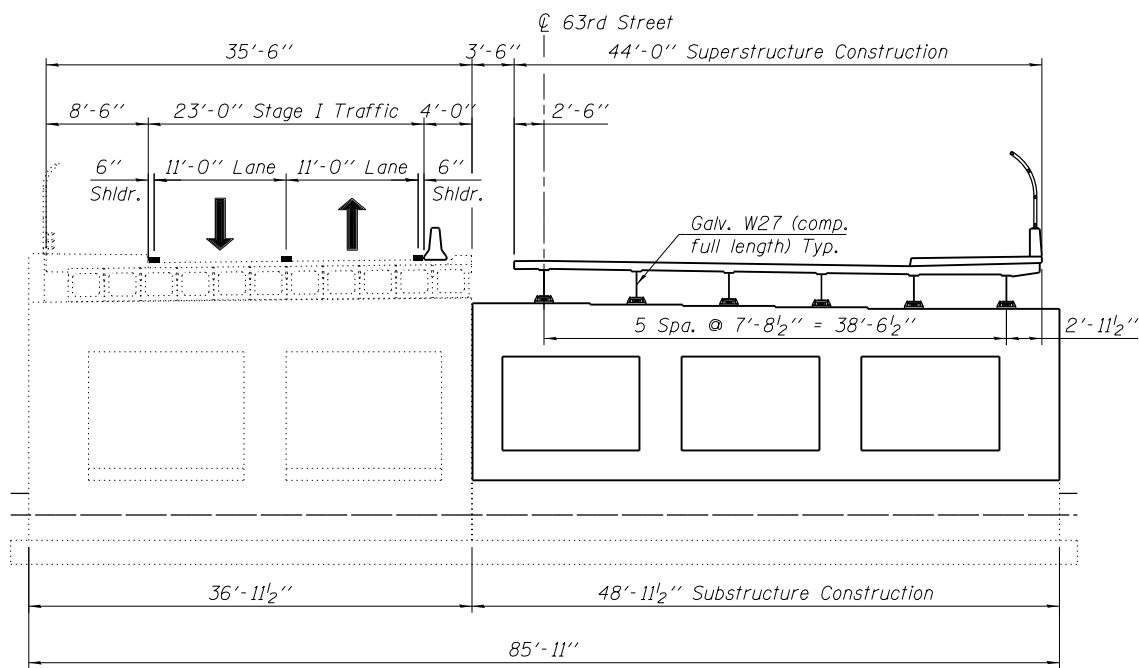

**STAGE I CONSTRUCTION**  
(Pier 1 shown, looking East)

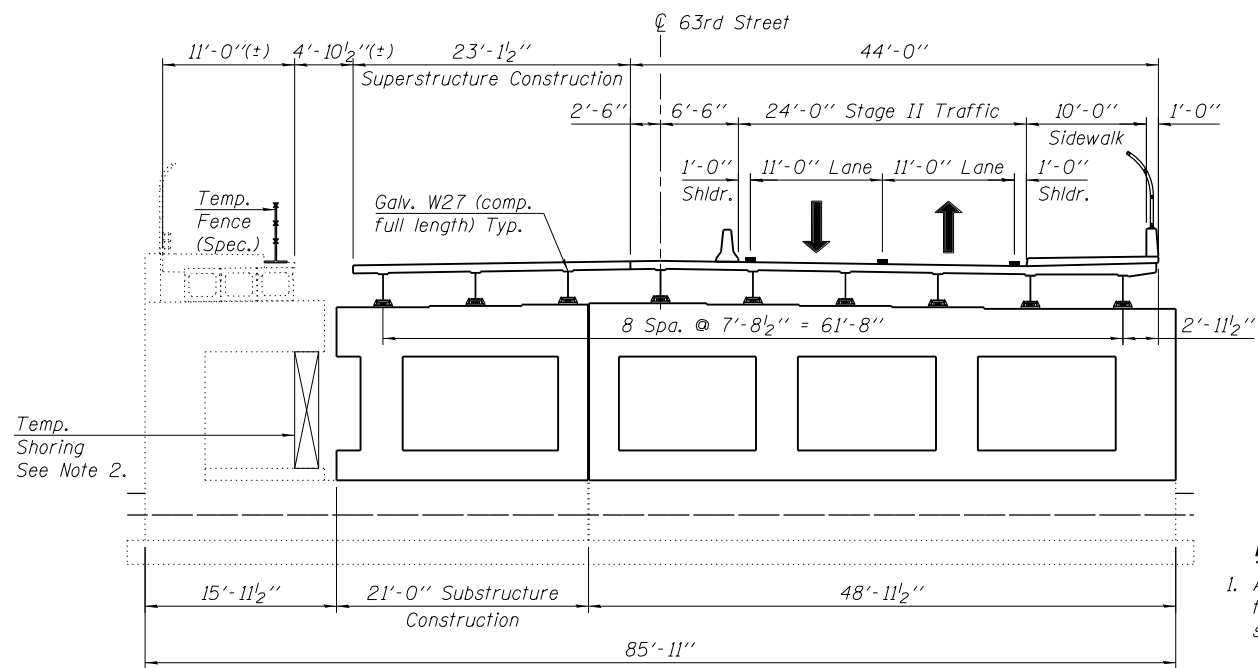

**STAGE II CONSTRUCTION**  
(Pier 1 shown, looking East)

**NOTES**

- Access to the CTA Red Line station shall be maintained throughout construction. During Stages I & II the North sidewalk shall remain open.
- At each Pier, provide Temporary Shoring at the start of Stage II Removal. The Temporary Shoring shall be designed for the following unfactored loads:  
Dead Load=212 kips  
Live Load= 27 kips
- The existing sidewalks may contain asbestos cement ducts. Ducts attached to the bridge fascias may also contain asbestos. The Contractor is responsible for removal and proper disposal of all existing ducts/conduit. This cost shall be included in Removal of Existing Superstructures (unless paid elsewhere).
- Removal and disposal of the existing metal railings, fence and light poles shall be included in Removal of Existing Superstructures.

H:\projects\2015\02\21\CAD\AS+Structure\06-1149-Final\00\Di06015-s03-staging.dgn 5/20/2015 11:23:58 AM

USER NAME =	DESIGNED - J.Z.	REVISED -
PLLOT SCALE =	CHECKED - J.A.Z.	REVISED -
PLLOT DATE =	DRAWN - E.E.J.	REVISED -
	DATE - 5/17/2013	REVISED -

F.A.I. RTE.	SECTION	COUNTY	TOTAL SHEETS	SHEET NO.
94	1920-B	COOK	137	62
CONTRACT NO. 60J15				
ILLINOIS FED. AID PROJECT				