

**GENERAL NOTES**

Length shall be determined by the Contractor. All steel pipe shall be standard weight (Sch. 40) unless otherwise noted.  
 Traversable Steel Pipe System details shown for Box Culvert End Sections. Traversable Steel Pipe System details for other culvert end sections similar.  
 All components of the Traversable Steel Pipe System shall be galvanized according to the requirements of AASHTO M 111 or M 232 as applicable.  
 Fabrication of the Traversable Steel Pipe System shall conform to the requirements in Section 505 of the Standard Specifications unless noted otherwise.  
 Structural steel shapes and plates shall conform to the requirements of Article 1006.04 of the Standard Specifications. Steel pipes shall conform to the requirements of ASTM A 53 (Type E or S), Grade B.  
 Anchor rods shall conform to the requirements of ASTM F1554, Grade 105. Anchor rods shall be drilled and epoxy grouted according to the requirements of Section 584 of the Standard Specifications. The chemical adhesive system shall be capable of achieving a minimum proof load of 5000 pounds and an ultimate shear capacity of 8000 pounds per anchor.  
 Bolts and thru bolts shall conform to the requirements of Article 1006.08 of the Standard Specifications except threaded rods conforming to the requirements of ASTM F1554, Grade 105 may be used for the thru bolts.  
 The minimum edge distance from the center of a hole to the free edge of a structural shape or plate shall be 1 1/2" unless noted otherwise.  
 Bolts and anchor rods shall be snug tightened by a few impacts of an impact wrench or the full force of a worker using an ordinary spud wrench unless otherwise noted.  
 All cost associated with fabricating, furnishing, and installing the Traversable Steel Pipe System will be paid for at the contract unit price per lined foot for Traversable Pipe Grate.

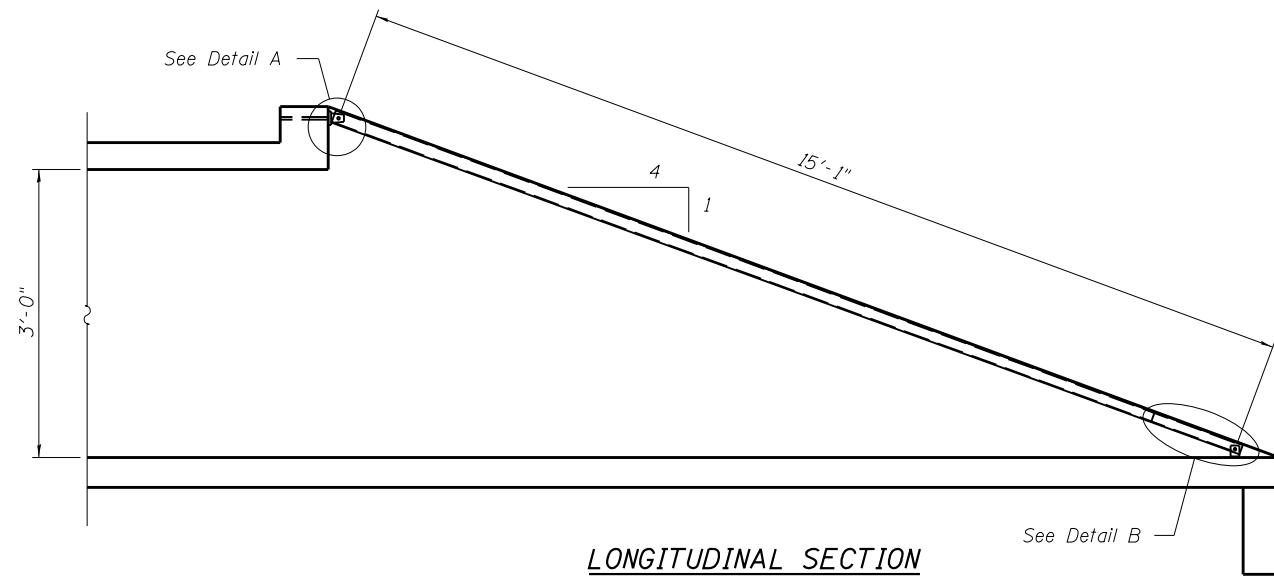

**LONGITUDINAL SECTION**

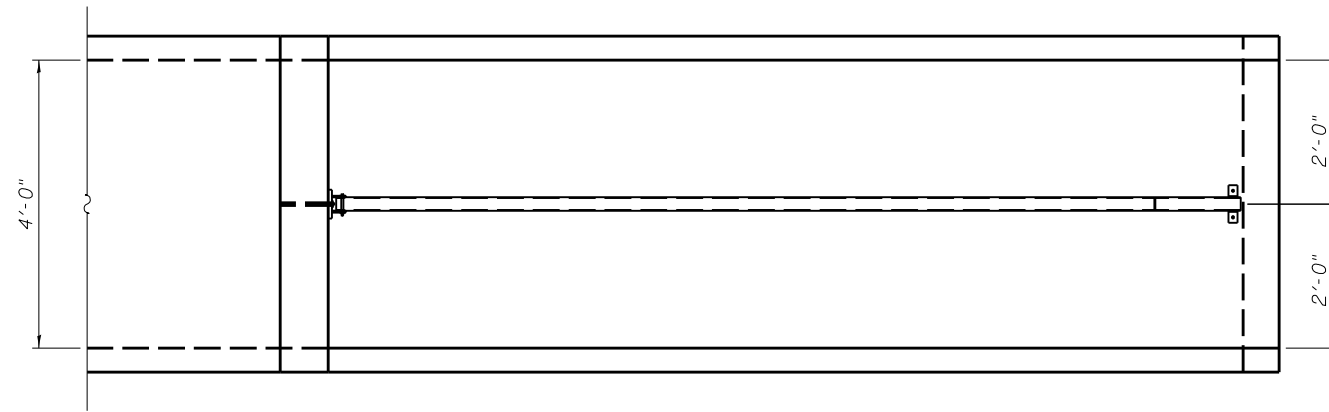

**PLAN**

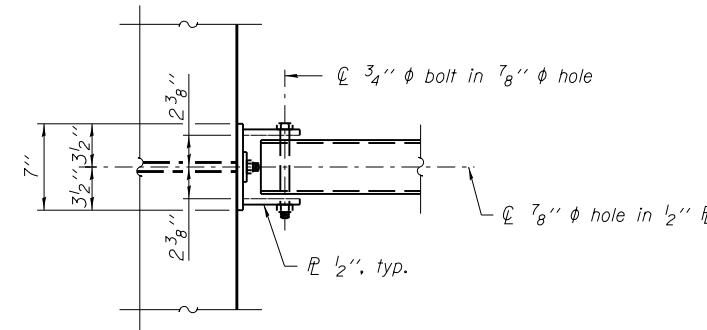

**VIEW A-A**

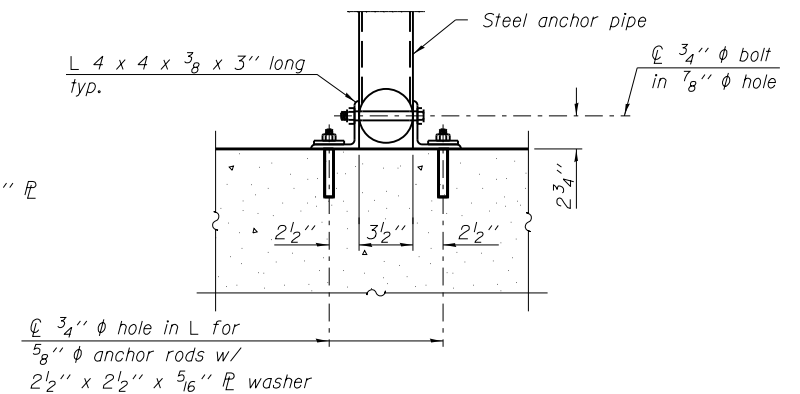

**SECTION B-B**

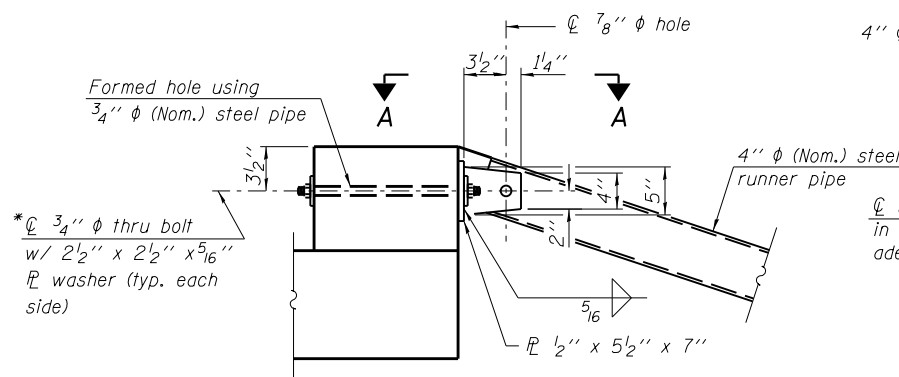

**DETAIL A**

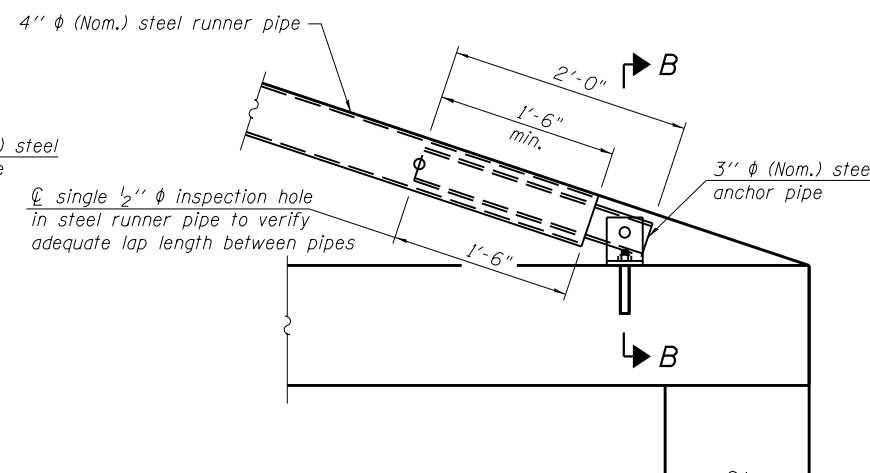

**DETAIL B**

\*\*\* The lap length between pipes may be adjusted in the field to accommodate construction tolerances but shall not be less than 9".

\*Ø 3/4" Ø thru bolt w/ 2 1/2" x 2 1/2" x 5/16" PL washer (typ. each side)  
 \*Bolt shall be tightened per Art. 505.04(f)(2)d of the Standard Specifications

FILE NAME = W:\Projects\2010\100120 PTB 157\25\cadd\Structural\Dgn\103 - IL 92 Culverts\Station 925+59.49\45\Final\_Submit\13.0320\925+59.49\64H11-005-GratingSystem.dwg



USER NAME = hferstl	DESIGNED - AEU	REVISED -
PLOT SCALE =	CHECKED - DLS	REVISED -
PLOT DATE = 3/20/2013	DRAWN - AWH	REVISED -
	CHECKED - AEU	REVISED -

**STATE OF ILLINOIS  
 DEPARTMENT OF TRANSPORTATION**

**TRAVERSABLE STEEL PIPE SYSTEM  
 STA. 925 + 59.49 LT. & RT.**

SHEET NO. 5 OF 5 SHEETS

F.A.P. RTE.	SECTION	COUNTY	TOTAL SHEETS	SHEET NO.
599	(83MFT & 103MFT)W	ROCK ISLAND	340	184
FED. ROAD DIST. NO.			ILLINOIS FED. AID PROJECT	
			CONTRACT NO. 64H11	