

Existing Structure:
Single 4' x 4' box culvert built in 1940 under Section 66B-15d. The existing box will be extended to the south and a grouted drop box constructed. The existing box will be extended to the north and a grouted end section constructed. One lane of traffic to be maintained at all times utilizing staged construction.

No salvage.

INDEX OF SHEETS

1. General Plan & Elevation
2. Box Culvert End Section with Drop Box
3. Box Culvert End Section with Drop Box Details
4. Traversable Steel Pipe System with Drop Box
5. Box Culvert End Section
6. Box Culvert End Section Details
7. Traversable Steel Pipe System

GENERAL NOTES

1. The barrel slab and walls shall be poured monolithically with the drop box.
2. All exposed concrete edges shall be chamfered $\frac{3}{4}$ " unless otherwise noted.
3. All construction joints shall be bonded.
4. The contract unit price "Each" for Box Culvert End Sections of the culvert End Section specified shall include the Concrete Box Culverts, Reinforcement Bars, Earth Excavation where required and necessary grading to fit the structures as shown, or to the slope.
5. Plan dimensions and details relative to existing plans are subject to nominal construction variations. The Contractor shall field verify existing dimensions and details affecting new construction and make necessary approved adjustments prior to construction or ordering of materials. Such variations shall not be cause for additional compensation for a change in scope of the work, however, the Contractor will be paid for the quantity actually furnished at the unit price bid for the work.
6. This work shall be done according to the applicable portion of of 501, 503, 505, 508, 540 and 584 of the Standard Specifications.
7. Drainage holes shall conform to the requirements of Article 503.11 of the Standard Specifications.
8. A precast option will not be allowed at this site.
9. Nonwoven geotextile fabric shall conform to the requirements of Art. 1080.01 of the Standard Specifications. The minimum weight of the fabric shall be 6 ounces per square yard.

DESIGN SPECIFICATIONS

2002 AASHTO Standard Specifications

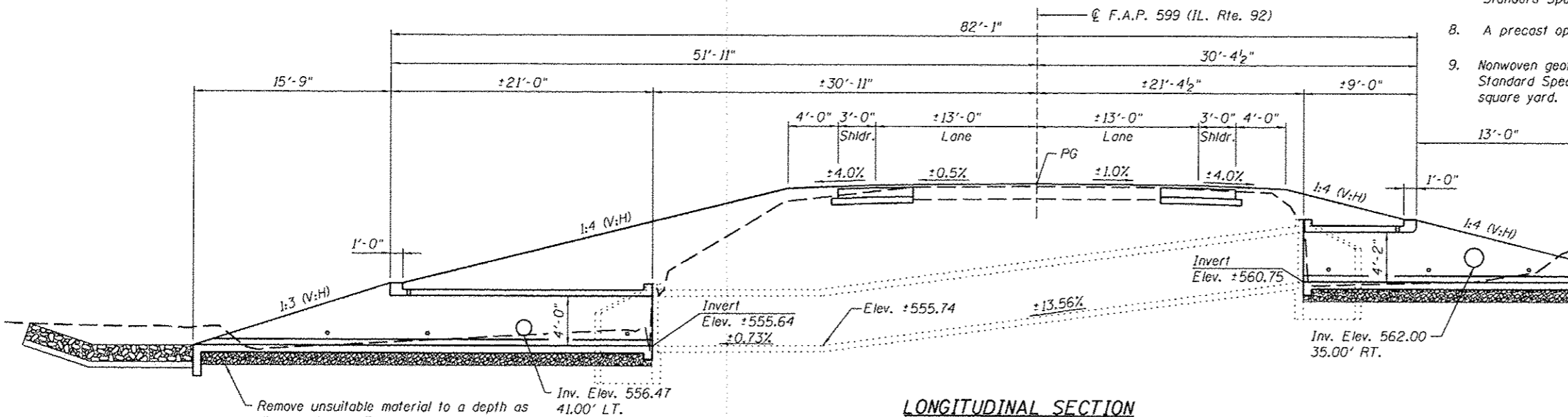

LONGITUDINAL SECTION

Remove unsuitable material to a depth as directed by the Engineer and replace with Rock Fill. A depth of 1'-0" has been assumed to determine quantities, typ.

TOTAL BILL OF MATERIAL

ITEM	UNIT	TOTAL
Turf Reinforcement Mat	Sq. Yd.	40
Stone Riprap, Class A4	Sq. Yd.	25
Filter Fabric	Sq. Yd.	25
Removal and Disposal of Unsuitable Material for Structures	Cu. Yd.	20
Box Culvert End Sections, Culvert No. 11	Each	1
Box Culvert End Sections, Culvert No. 12	Each	1
Traversable Pipe Grate	Foot	25.8
Rock Fill	Ton	35

DESIGN STRESSES

FIELD UNITS

f'c = 3,500 psi
fy = 60,000 psi (Reinforcement)

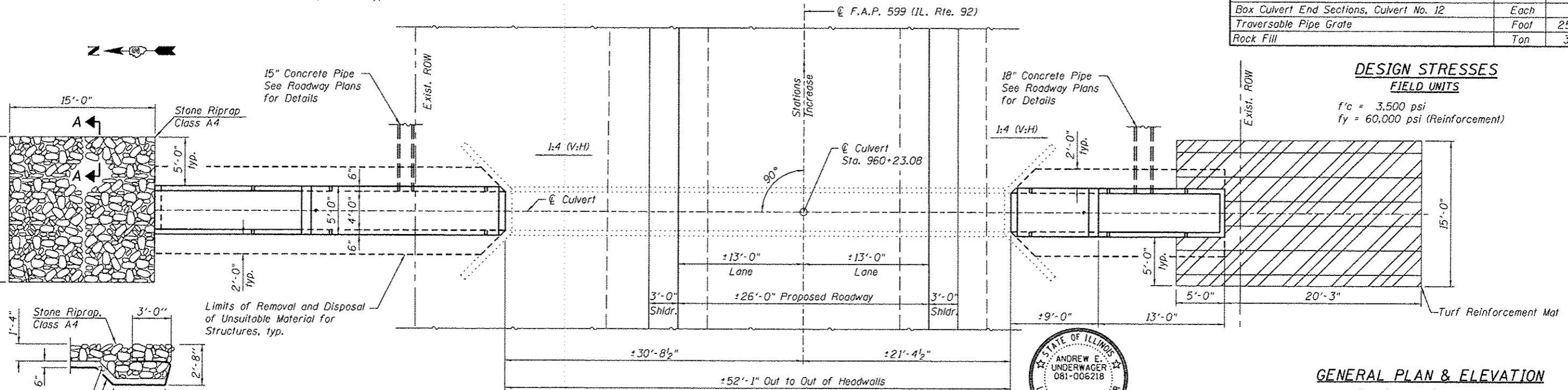

PLAN

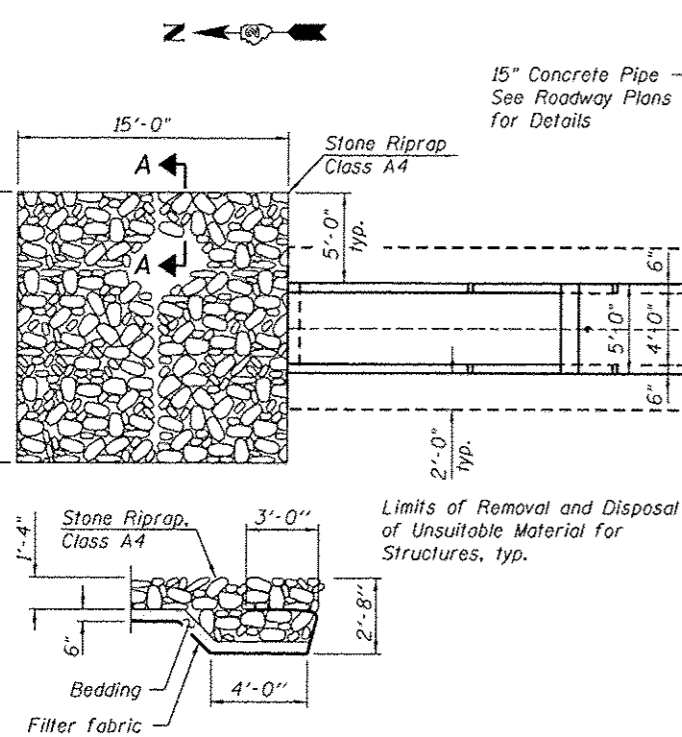

SECTION A-A

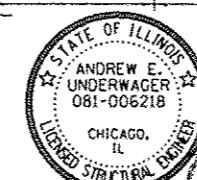

Signature: *Andrew E. Underwager*
Date: 3-13-2013
License Expires: 11-30-2014

GENERAL PLAN & ELEVATION
ILLINOIS ROUTE 92
F.A.P. RTE 599 - SEC. (83MFT & 103MFT)W
ROCK ISLAND COUNTY
STATION 960+23.08

STATE OF ILLINOIS
DEPARTMENT OF TRANSPORTATION

GENERAL PLAN & ELEVATION
STA. 960 + 23.08
SHEET NO. 1 OF 7 SHEETS

F.A.P. RTE.	SECTION	COUNTY	TOTAL SHEETS	SHEET NO.
599	(83MFT & 103MFT)W	ROCK ISLAND	340	192
FED. ROAD DIST. NO.			ILLINOIS FED. AID PROJECT	

FILE NAME: M:\Projects\28181\28181.dwg
 PROJECT: ILL. 92 Culvert Station 960+23.08
 DRAWN: AH
 CHECKED: DLS
 DESIGNED: AEU
 DATE: 3/28/2013

WILLS BURKE KELSEY ASSOCIATES LTD.
116 West Main Street, Suite 201
St. Charles, Illinois 60174