

F.A.P. RTE.	SECTION	COUNTY	TOTAL SHEETS	SHEET NO.
334	**	McHENRY	98	74
STA.		TO STA.		
FED. ROAD DIST. NO. 1 ILLINOIS FED. AID PROJECT				

•• 111 RS-5 & 116 B-1

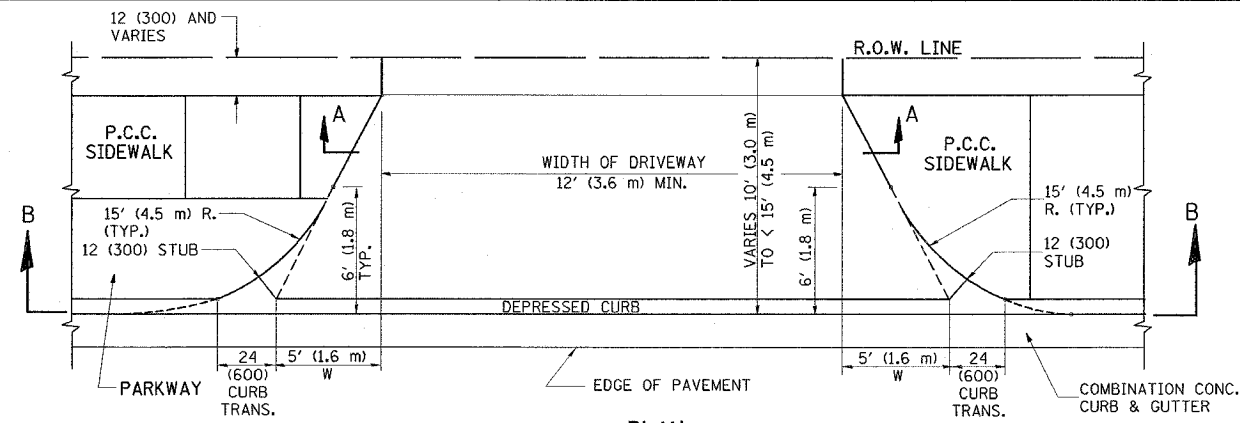

PLAN  
10' (3.0 m) TO < 15' (4.5 m)

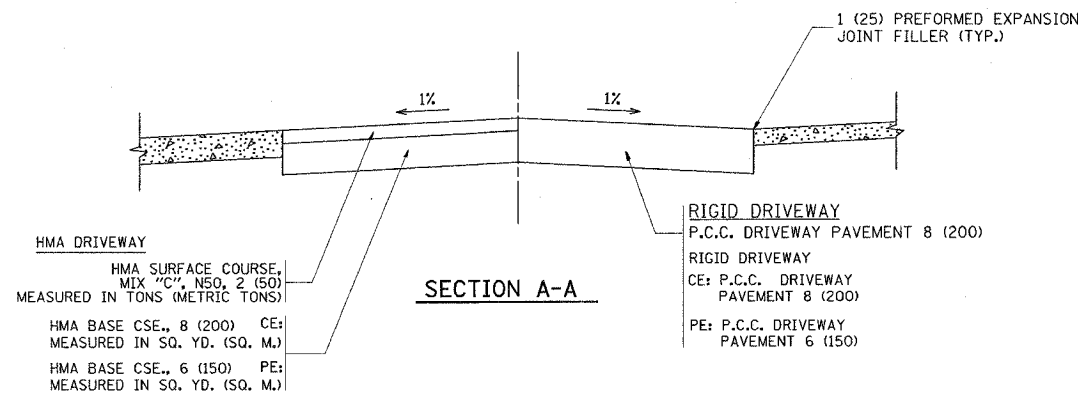

SECTION A-A

HMA DRIVEWAY  
HMA SURFACE COURSE, MIX "C", N50, 2 (50) MEASURED IN TONS (METRIC TONS)  
HMA BASE CSE., 8 (200) CE: MEASURED IN SQ. YD. (SQ. M.)  
HMA BASE CSE., 6 (150) PE: MEASURED IN SQ. YD. (SQ. M.)

RIGID DRIVEWAY  
P.C.C. DRIVEWAY PAVEMENT 8 (200)  
RIGID DRIVEWAY  
CE: P.C.C. DRIVEWAY PAVEMENT 8 (200)  
PE: P.C.C. DRIVEWAY PAVEMENT 6 (150)

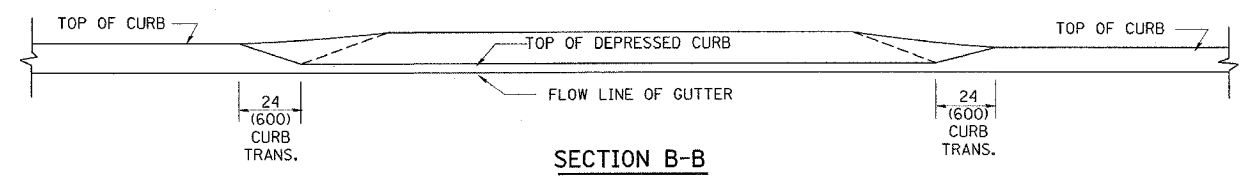

SECTION B-B

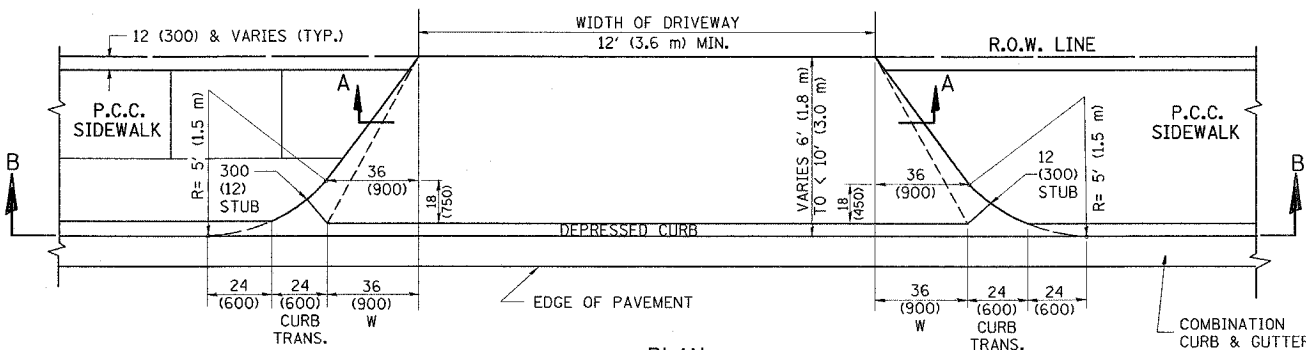

PLAN  
6' (1.8 m) TO < 10' (3.0 m)

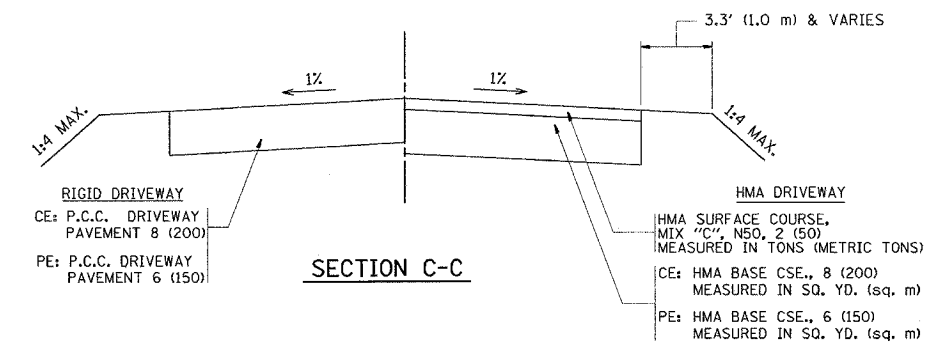

SECTION C-C

RIGID DRIVEWAY  
CE: P.C.C. DRIVEWAY PAVEMENT 8 (200)  
PE: P.C.C. DRIVEWAY PAVEMENT 6 (150)

HMA DRIVEWAY  
HMA SURFACE COURSE, MIX "C", N50, 2 (50) MEASURED IN TONS (METRIC TONS)  
CE: HMA BASE CSE., 8 (200) MEASURED IN SQ. YD. (SQ. M.)  
PE: HMA BASE CSE., 6 (150) MEASURED IN SQ. YD. (SQ. M.)

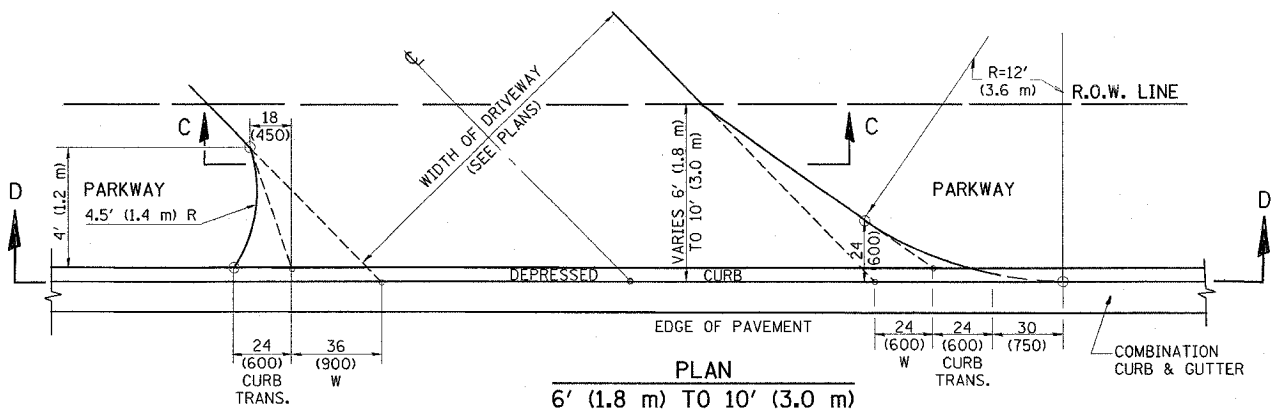

PLAN  
6' (1.8 m) TO 10' (3.0 m)

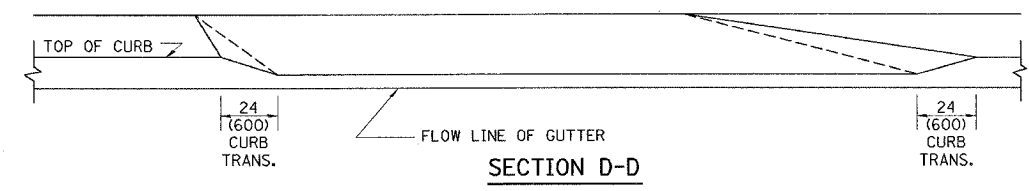

SECTION D-D

GENERAL NOTES

DRIVEWAY SLOPES, LOCATIONS, & GEOMETRIC LAYOUT SHALL BE IN ACCORDANCE WITH THE LATEST EDITION OF THE "HANDBOOK FOR POLICY ON PERMITS FOR ACCESS DRIVEWAYS TO STATE HIGHWAYS". FOR FURTHER LAYOUT REQUIREMENTS, REFER TO ILLUSTRATION 10 IN THE PERMIT HANDBOOK. WHERE SIDEWALKS EXIST, DRIVEWAYS SHALL BE REPLACED WITH RIGID PAVEMENT. WHERE NO SIDEWALKS EXIST, DRIVEWAYS SHALL BE REPLACED IN KIND. SIDEWALK CROSS SLOPE THRU DRIVEWAY AREA TO BE A MAXIMUM OF 1:50.

WHEN THE DISTANCE BETWEEN R.O.W. AND THE BACK OF CURB IS EQUAL TO OR LESS THAN 8' (2.4 m), THE P.C.C. SIDEWALK SHALL EXTEND TO THE BACK OF CURB.

THE RESIDENT ENGINEER SHALL CONTACT THE TRAFFIC PERMIT OFFICE AT 847/ 705-4131 FOR ANY QUESTIONS ON DRIVEWAYS SHOWN IN THE PLANS; SPECIFICALLY IN REFERENCE TO ADDITIONAL AND/OR RELOCATION/REMOVAL OF A DRIVEWAY.

COMBINATION CONCRETE CURB & GUTTER SHALL BE MEASURED STRAIGHT ACROSS THE DRIVEWAY. NO ADDITIONAL COMPENSATION WILL BE ALLOWED FOR THE CURB & GUTTER TRANSITION.

THE 1 (25) PREFORMED EXPANSION JOINT FILLER WILL NOT BE PAID SEPARATELY, BUT SHALL BE CONSIDERED INCLUDED IN THE COST OF THE P.C.C. DRIVEWAY PAVEMENT OR P.C.C. SIDEWALK.

"W" VARIES FROM 36 (900) TO 5' (1.5 m) PROPORTIONAL TO THE LENGTH (L), FROM 6' (1.8 m) TO 10' (3 m).

ALL DIMENSIONS ARE IN INCHES (MILLIMETERS) UNLESS OTHERWISE NOTED.

ILLINOIS DEPARTMENT OF TRANSPORTATION

DRIVEWAY DETAILS  
DISTANCE BETWEEN ROW AND FACE OF CURB < 15' (4.5 m)

REVISIONS	
NAME	DATE
R. SHAH	11/06/95
J. POLLASTRINI	08/12/96
J. POLLASTRINI	12/14/96
A. ABBAS	03/21/97
T. HOLTZ	04/08/97
M. GOMEZ	04/06/01
P. LOFLEUR	04/15/03
R. BORO	01/01/07

SCALE: VERT. NONE  
HORIZ.

DRAWN BY  
CHECKED BY

BD400-02 (BD-02)

PLOT DATE = 5/18/2007  
FILE NAME = P:\projects\bd02.dgn  
USER = jh195 / JN  
USER NAME = jh195