

F.A.P. RTE.	SECTION	COUNTY	TOTAL SHEETS	SHEET NO.
335	119R-2	LAKE	439	282
STA. 432+83.12		TO STA. 470+56.84		
FED. ROAD DIST. NO.	ILLINOIS	FED. AID PROJECT		

BILL OF MATERIAL

60B01

Bar	No.	Size	Length	Shape
$h_{50}(E)$	12	#8	32'-0"	—
$h_{51}(E)$	40	#5	30'-0"	—
$h_{52}(E)$	24	#8	27'-10"	—
$h_{53}(E)$	56	#5	24'-9"	—
$h_{54}(E)$	6	#5	21'-6"	—
$h_{55}(E)$	12	#5	35'-5"	—
$n_{50}(E)$	152	#5	12'-0"	—
$n_{51}(E)$	154	#9	13'-4"	—
$p_{50}(E)$	24	#8	34'-0"	—
$p_{51}(E)$	12	#10	32'-2"	—
$p_{52}(E)$	12	#8	21'-6"	—
$p_{53}(E)$	12	#10	21'-6"	—
$p_{54}(E)$	24	#8	39'-7"	—
$p_{55}(E)$	12	#10	37'-9"	—
$p_{56}(E)$	24	#9	17'-0"	7
$p_{57}(E)$	4	#5	22'-6"	—
$p_{58}(E)$	4	#5	18'-2"	—
$p_{59}(E)$	4	#5	21'-9"	—
$p_{60}(E)$	8	#5	23'-6"	—
$p_{61}(E)$	4	#5	6'-3"	—
$s_{50}(E)$	152	#5	17'-6"	—
$s_{51}(E)$	63	#4	11'-5"	—
$s_{52}(E)$	176	#5	12'-3"	—
$s_{53}(E)$	204	#5	11'-11"	—
$s_{54}(E)$	32	#4	10'-3"	—
$s_{55}(E)$	103	#4	2'-11"	—
$s_{56}(E)$	113	#4	7'-0"	—
$t_{50}(E)$	174	#8	9'-2"	—
$u_{50}(E)$	16	#5	9'-1"	—
$u_{51}(E)$	20	#5	8'-0"	—
$v_{50}(E)$	154	#9	11'-9"	—
$w_{50}(E)$	30	#7	31'-4"	—
$w_{51}(E)$	40	#7	26'-1"	—
Structure Excavation		Cu Yd	411	
Concrete Structures		Cu Yd	384	
Reinforcement Bars, Epoxy Coated		Pound	50,740	
Furnishing Steel Piles, HP14x73		Foot	3,864	
Driving Piles		Foot	3,864	
Test Pile Steel HP14x73		Each	1	
Pile Shoes		Each	70	
Concrete Sealer		Sq Ft	4730	
Bar Splicers		Each	54	
Conduit Embedded In Structure, 4" Dia., PVC		Foot	150.7	

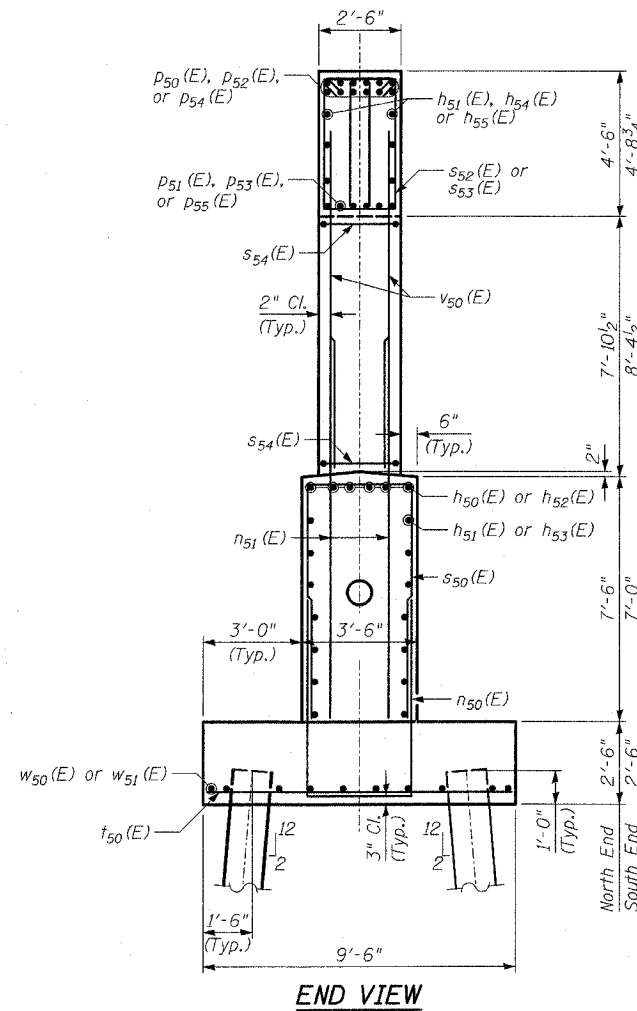

END VIEW

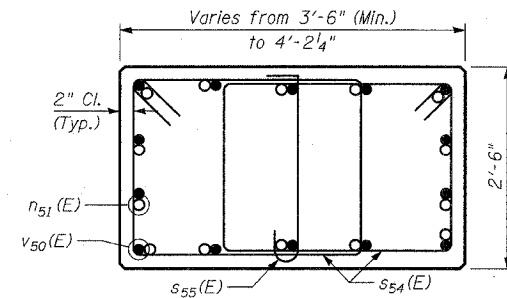

SECTION B-B

BARS $n_{50}(E)$, $s_{50}(E)$, $s_{56}(E)$, $u_{50}(E)$ & $u_{51}(E)$

Bar	D	E
$n_{50}(E)$	4'-5"	3'-2"
$s_{50}(E)$	7'-2"	3'-2"
$s_{56}(E)$	2'-5"	2'-2"
$u_{50}(E)$	3'-0"	3'-1"
$u_{51}(E)$	3'-0"	2'-0"

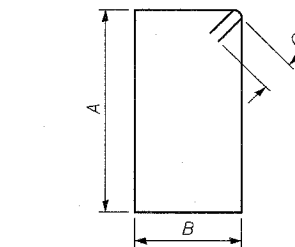

BARS $s_{51}(E)$ THRU $s_{54}(E)$

Bar	A	B	C
$s_{51}(E)$	2'-2"	3'-2"	4 1/2"
$s_{52}(E)$	4'-4"	1'-4"	5 1/2"
$s_{53}(E)$	4'-2"	1'-4"	5 1/2"
$s_{54}(E)$	2'-2"	2'-7"	4 1/2"

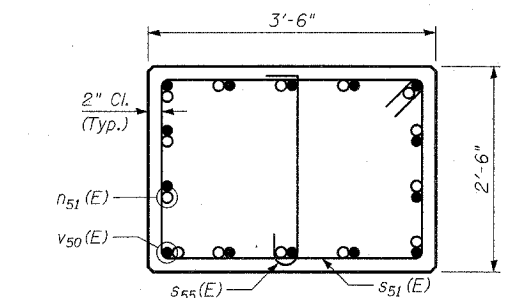

SECTION C-C

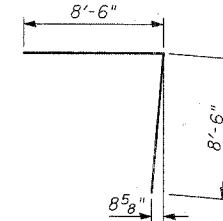

BAR $p_{56}(E)$

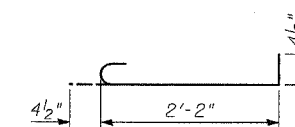

BAR $s_{55}(E)$

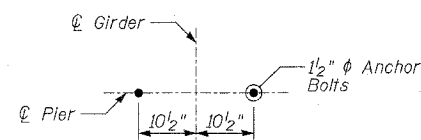

ANCHOR BOLT LAYOUT

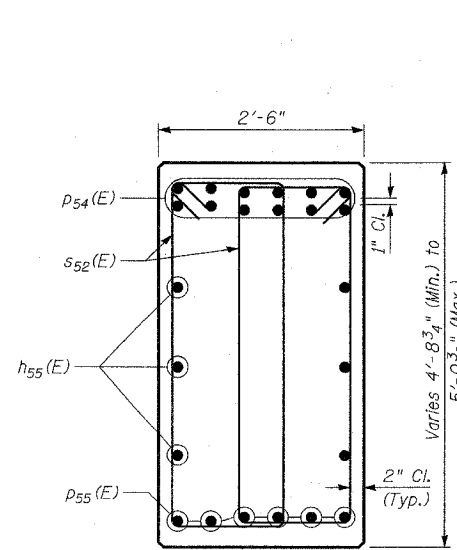

SECTION A-A

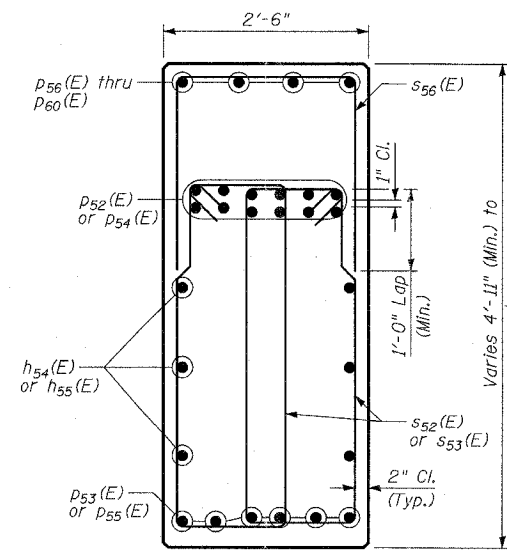

SECTION D-D

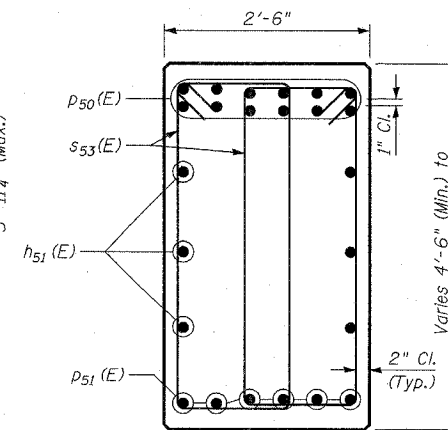

SECTION E-E

REVISIONS	
NAME	DATE

SHEET S-35 OF S-53

ILLINOIS DEPARTMENT OF TRANSPORTATION
PIER DETAILS
 ILLINOIS 60 OVER I-94
 F.A.P. RTE. 335 SECTION 119R-2
 LAKE COUNTY STA. 445+54.14
 S.N. 049-2012 ISTHA BRIDGE NO. 407
 DESIGNED BY: MI
 DRAWN BY: SNB
 CHECKED BY: MI

SCALE:
 DATE: MAY 8, 2007

TYLIN INTERNATIONAL

P:\6024581\1-60\Structural\TIN\60B01.dgn 05/03/2007 04:30:52 PM