

STATE OF ILLINOIS
DEPARTMENT OF TRANSPORTATION

FOR INFORMATIONAL
PURPOSES ONLY

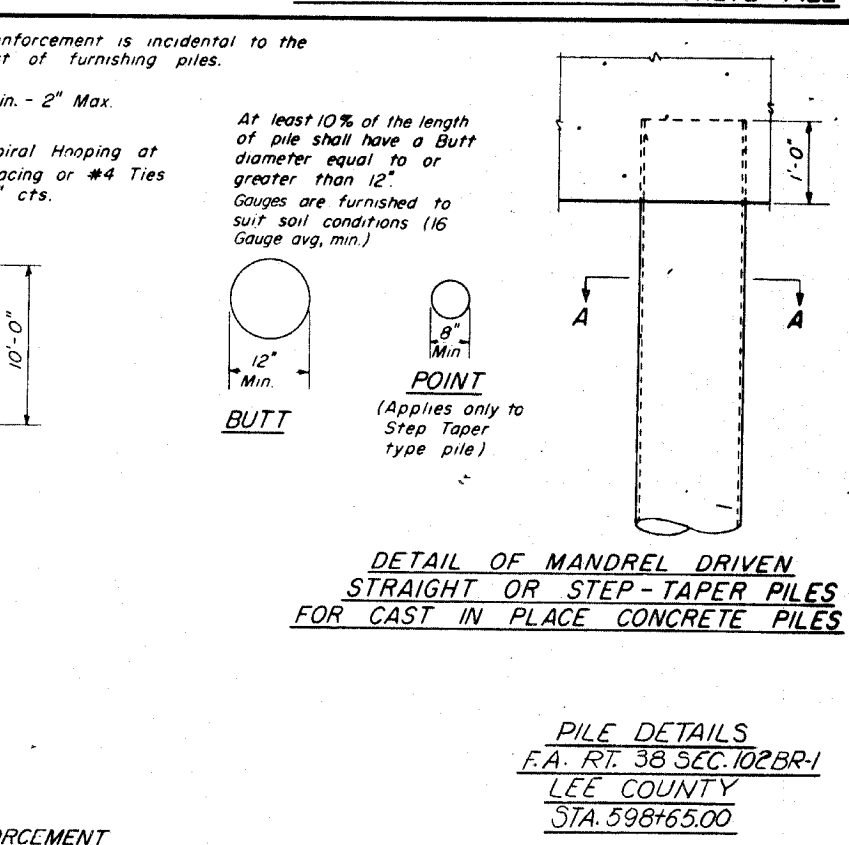
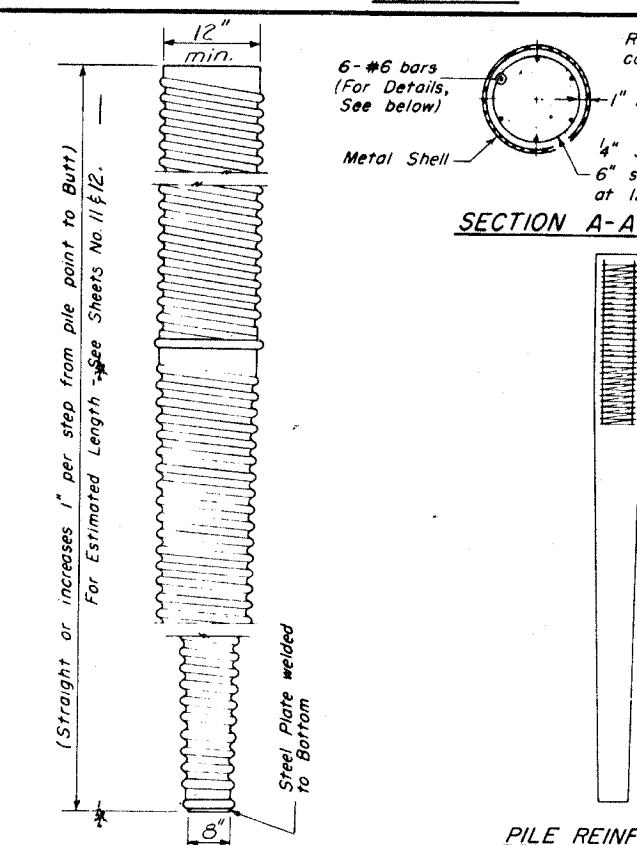
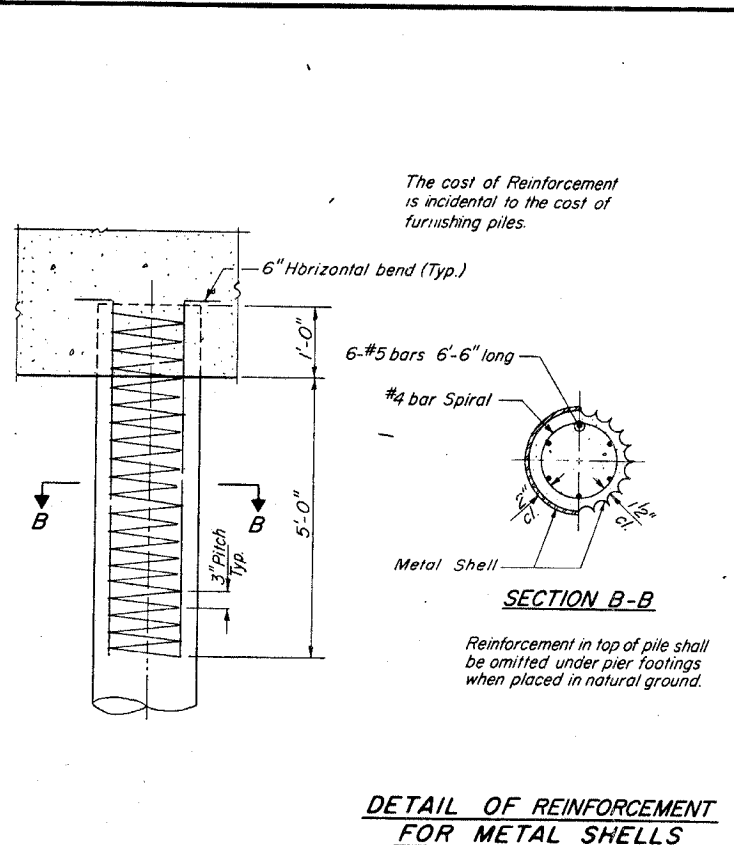
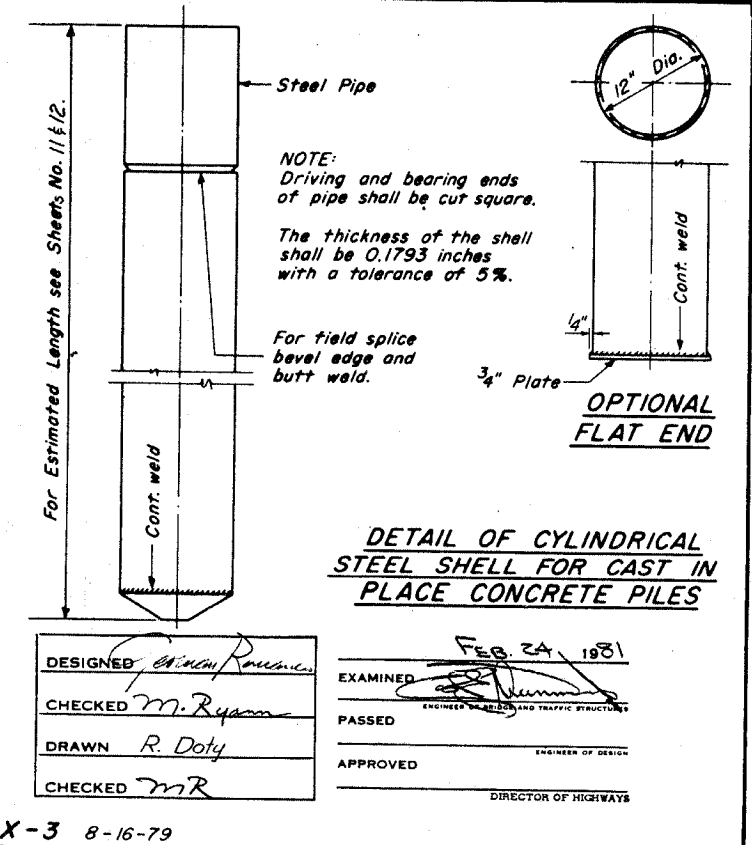
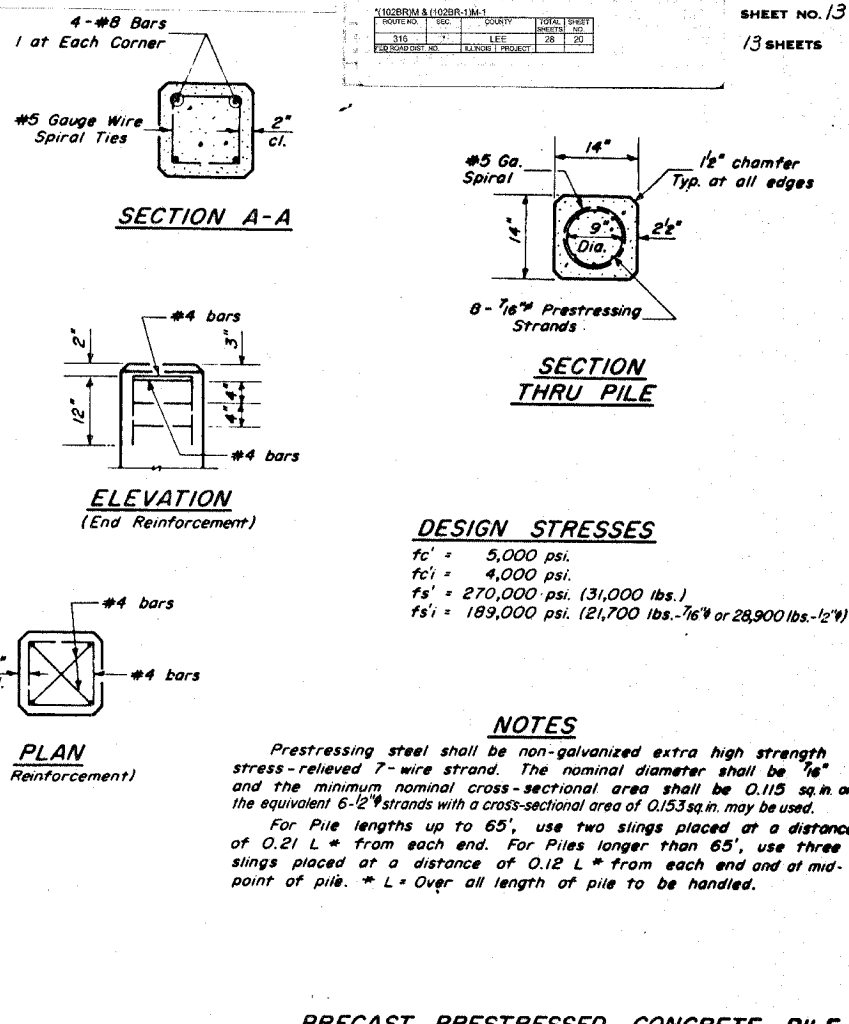
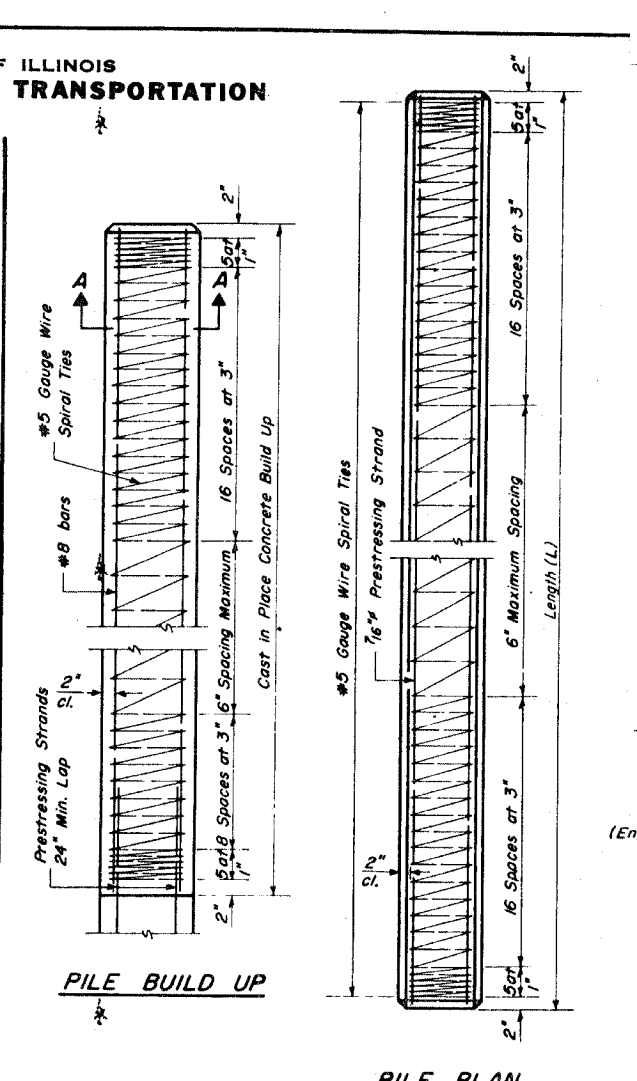
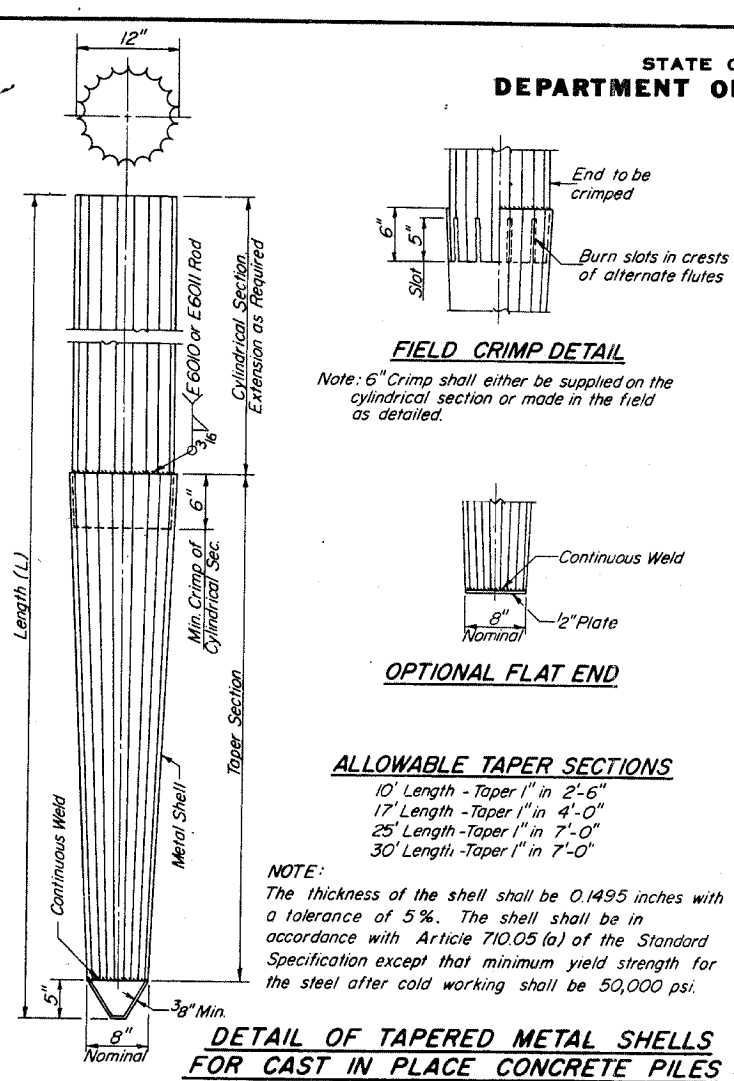
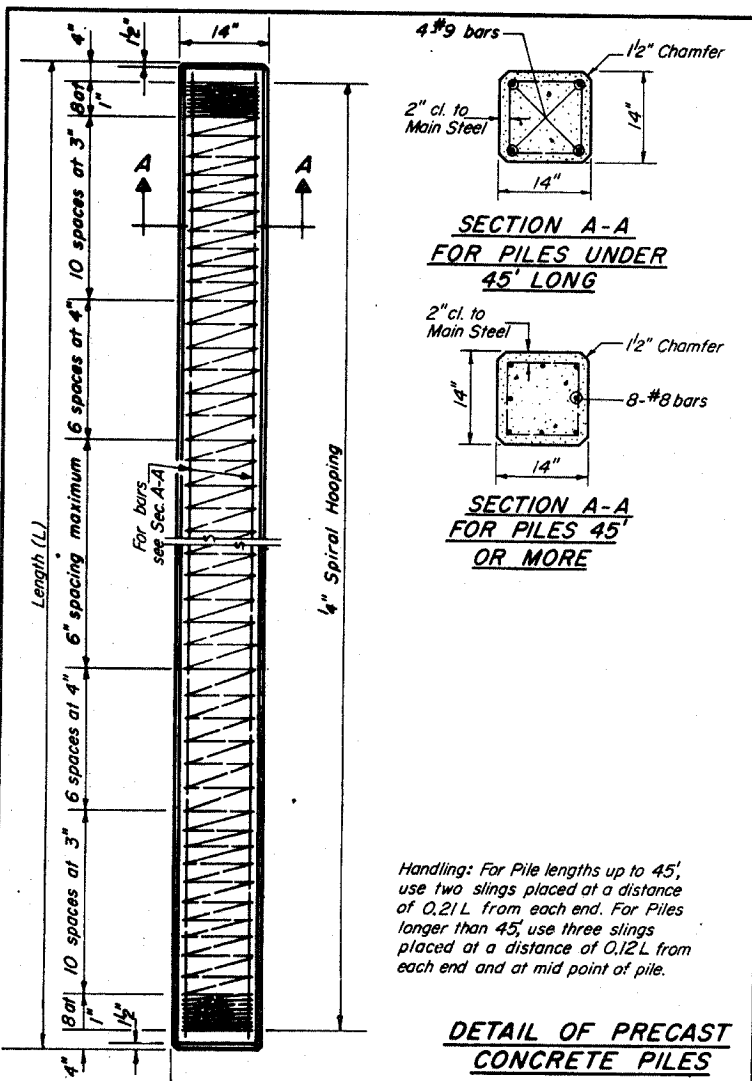

DESIGNED *[Signature]*
CHECKED *M. Ryan*
DRAWN *R. Doty*
CHECKED *MR*

EXAMINED *[Signature]*
PASSED
APPROVED
DIRECTOR OF HIGHWAYS

FEB 24 1981

PILE DETAILS
F.A. RT. 38 SEC. 102BR-1
LEE COUNTY
STA. 598+65.00