

CONTRACT NO. 64D47				
F.A.P. RTE.	SECTION	COUNTY	TOTAL SHEETS	SHEET NO.
22	(125BR-2)D	HENRY	34	29
STA.		TO STA.		
FED. ROAD DIST. NO.		ILLINOIS FED. AID PROJECT		

# EROSION CONTROL DETAILS FOR SILT FENCE

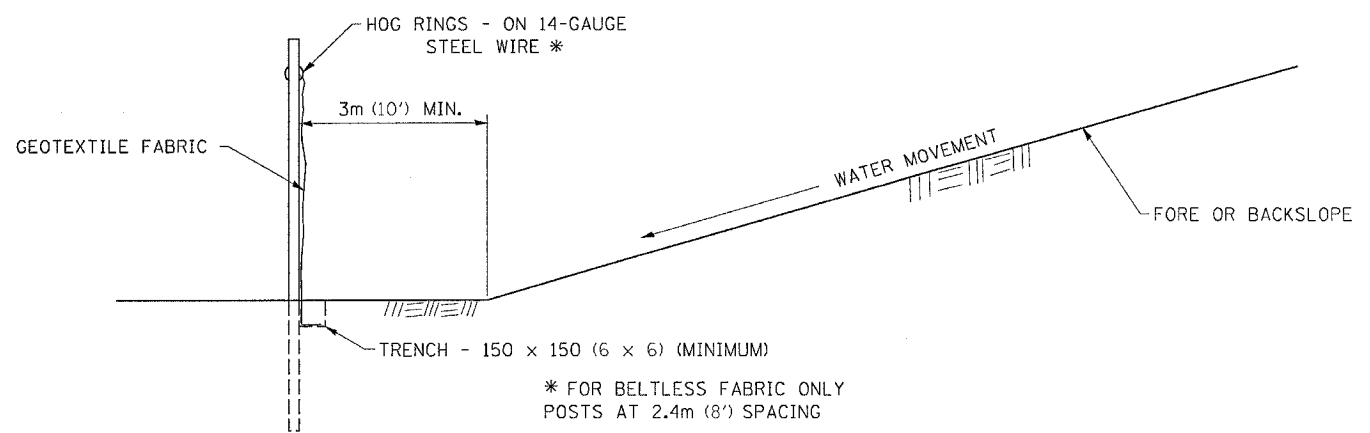
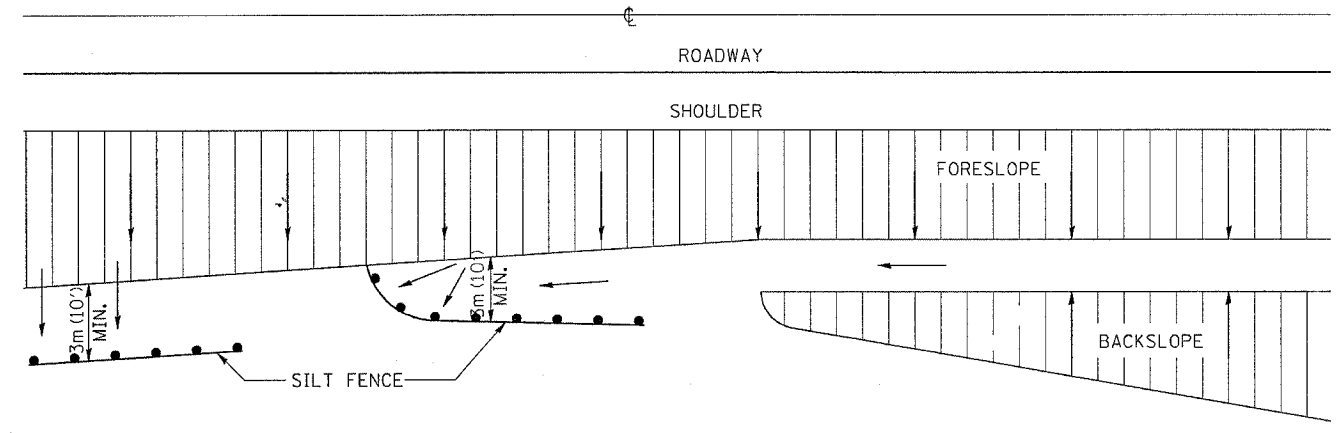

DETAILS OF SILT FENCE

ALL DIMENSIONS ARE IN MILLIMETERS (INCHES) UNLESS OTHERWISE NOTED.

# WITNESS MARKER FOR PERMANENT SURVEY MARKERS, TYPE II

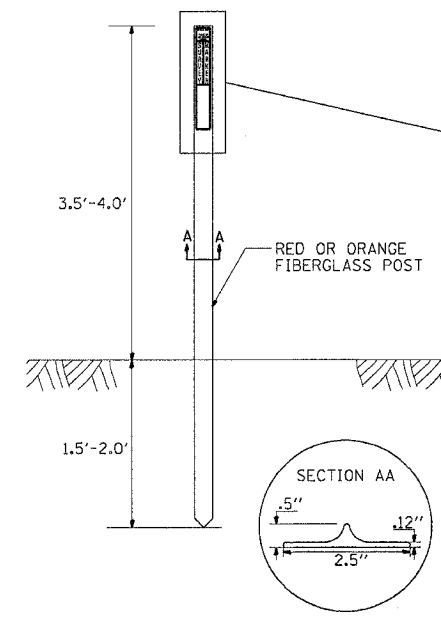

**GENERAL NOTES**  
 A WITNESS MARKER SHALL BE INSTALLED WITHIN 1' OF ALL PERMANENT SURVEY MARKERS TYPE II EXCEPT IN AREAS WHERE THE MARKER IS IN THE SIDEWALK. THIS WORK WILL BE INCLUDED TO THE CONTRACT UNIT PRICE PER EACH FOR PERMANENT SURVEY MARKERS, TYPE II.

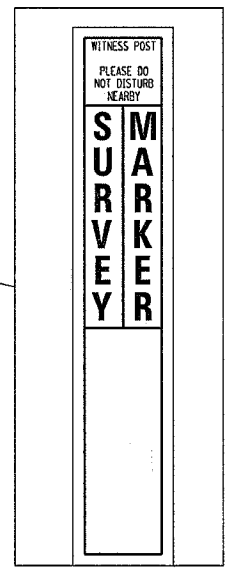

# PERMANENT SURVEY MARKERS, TYPE II

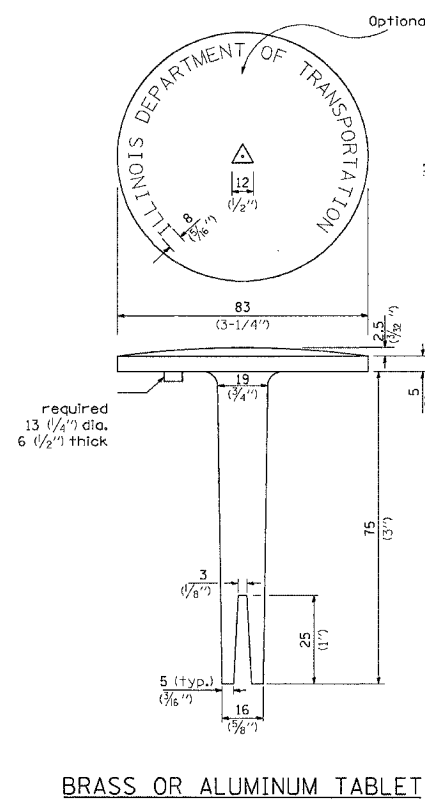

BRASS OR ALUMINUM TABLET

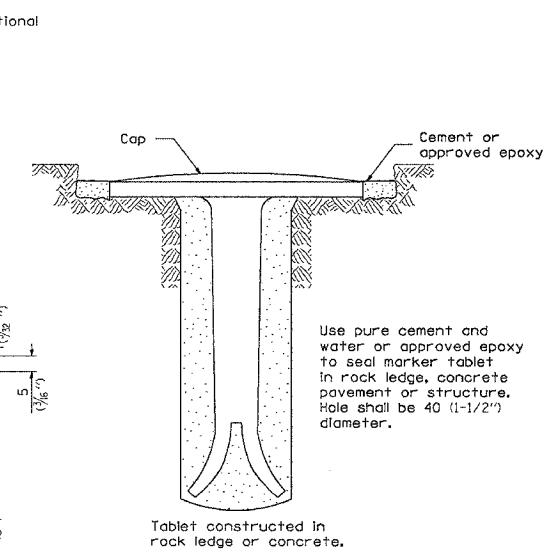

TYPE II

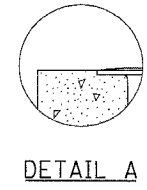

DETAIL A

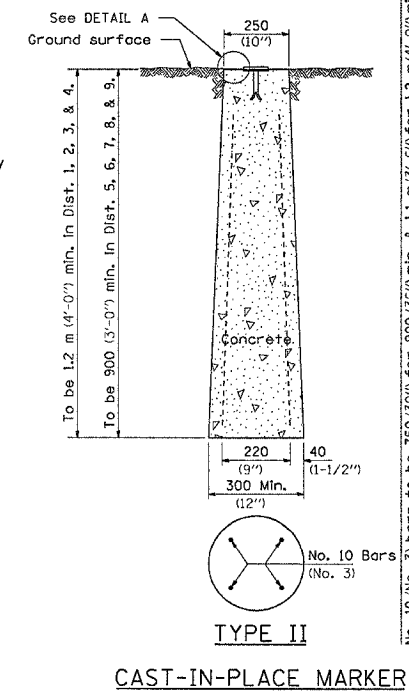

CAST-IN-PLACE MARKER

ALL DIMENSIONS ARE IN MILLIMETERS (INCHES) UNLESS OTHERWISE NOTED.

PLOT DATE = Wed May 15 11:34:55 2007  
 FILE NAME = c:\p\projects\2007\287\dr287.apl.dgn  
 PLOT SCALE = 50.0000 / IN.  
 REFERENCE = REF#