

STATE OF ILLINOIS
DEPARTMENT OF TRANSPORTATION

ROUTE NO.	SECTION	COUNTY	SPANS	SHEET	SHEET NO. 4	
F.A.P. 328	(8BR-D) B-1	WAYNE	39	20		
FED. ROAD DIST. NO. 7					ILLINOIS	FED. AID PROJECT

Contract #74041

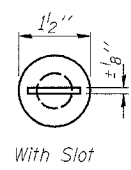
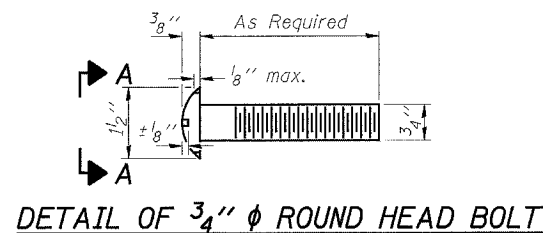

4-3/4" ϕ x 6" Round Head Bolts (With slot or approved recess in head) with locknut & flat washer. 7/8" ϕ holes in hollow structural section may be drilled in the field.

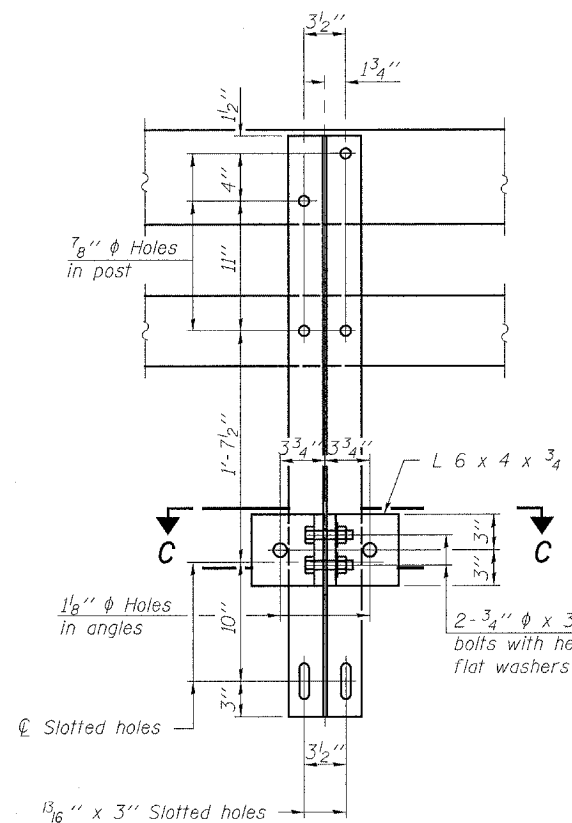

SECTION AT RAIL POST

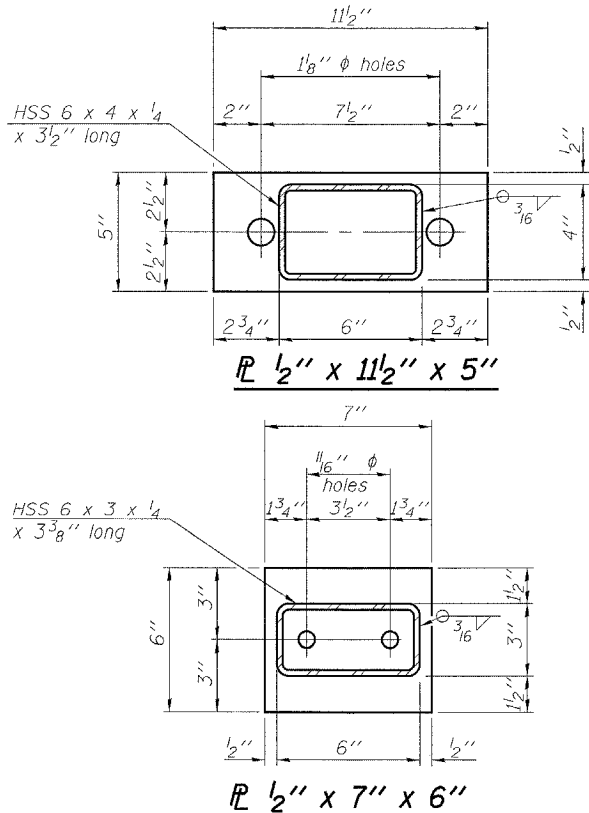

RAIL SPLICE CONNECTION AT EXPANSION JT.

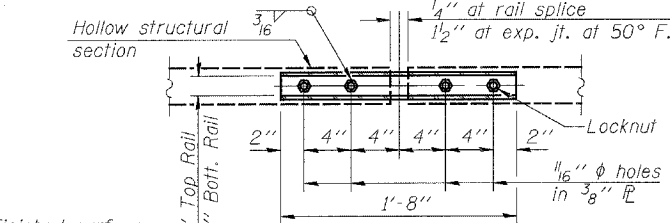
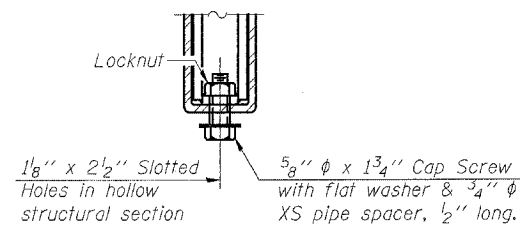

PLAN-BOTT. SPLICE R TYPICAL

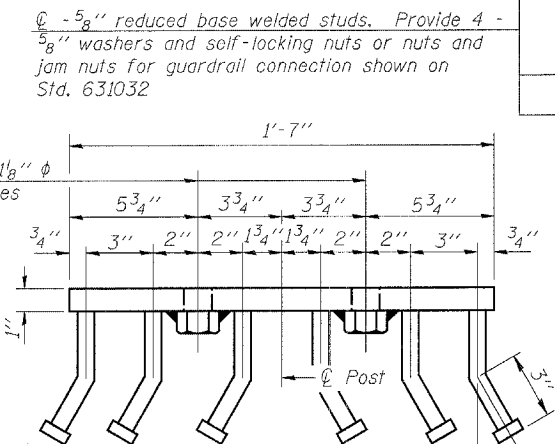

VIEW D-D

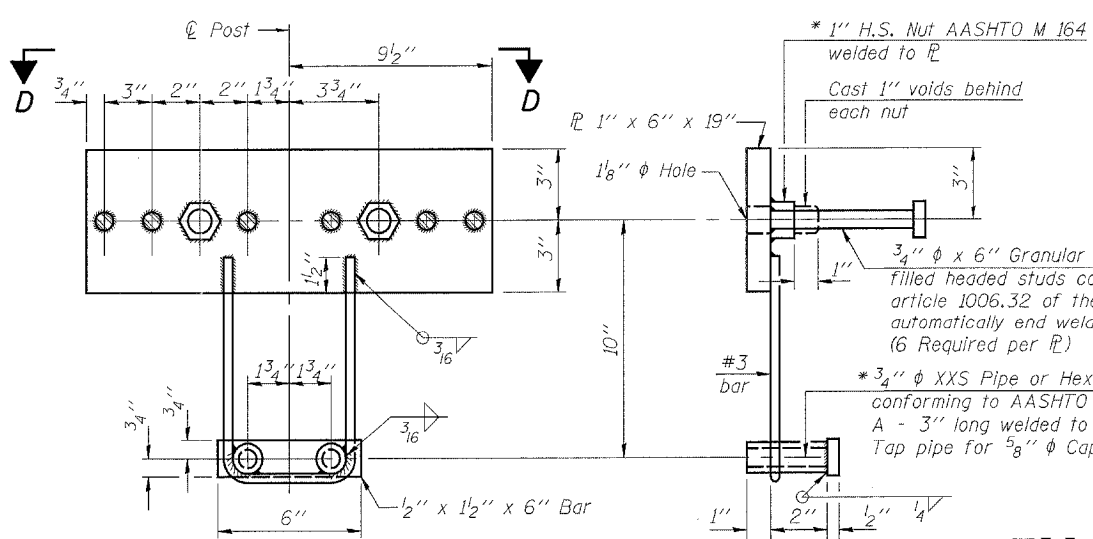

ANCHOR DEVICE

SECTION AT RAIL SPLICE

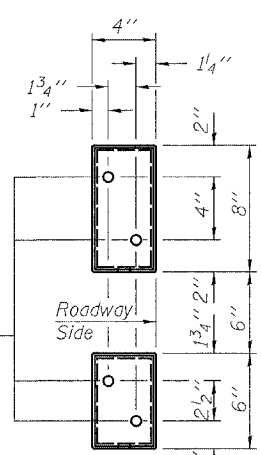

VIEW E-E

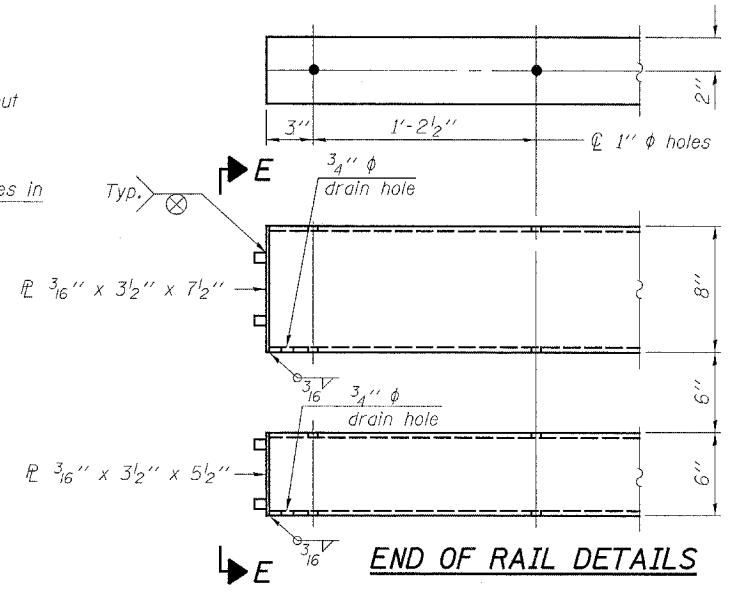

END OF RAIL DETAILS

Notes:
All field drilled holes shall be coated with an approved zinc rich paint before erection.
For multi-span bridges, sufficient 1/4" x 6" x 1'-2" galvanized steel shims shall be provided to align rail between adjacent spans. Cost included with Steel Railing, Type SM.
Steel rail elements shall be galvanized according to Article 509.05 of the Standard Specifications.
The studs of the anchor devices shall be placed below the top reinforcement bars and the outermost longitudinal reinforcement bar shall be placed directly above the studs of the rail post anchor device.
** For rail post spacing see sheets 5 and 6 of 13.

BILL OF MATERIAL

Item	Unit	Quantity
Steel Railing, Type SM	Foot	126

STEEL RAILING, TYPE SM
WITH CONCRETE WEARING SURFACE
F.A.P. ROUTE 328 - SECTION (8BR-1)B-1
WAYNE COUNTY
STATION 719+63.09
STRUCTURE NO. 096-0020

HORNER & SHIFRIN, INC.
ENGINEERS

DESIGNED	JJD
CHECKED	EML
DRAWN	JJD
CHECKED	EML

R-34CWS

11-1-06 (6'-3" Maximum Post Spacing) (5" minimum to 7'8" maximum CWS thickness)

* Threaded areas shall be plugged or blocked off during casting of beam. Galvanized after fabrication.