

F.A. RTE.	SECTION	COUNTY	TOTAL SHEETS	SHEET NO.
177	28	MADISON	7	5
STA. _____ TO STA. _____				
FED. ROAD DIST. NO. _____ ILLINOIS FED. AID PROJECT				
: E&U 9251 / FAS 1848 / FAU 9288				
: 27RS-2, 28, 29RS-2				

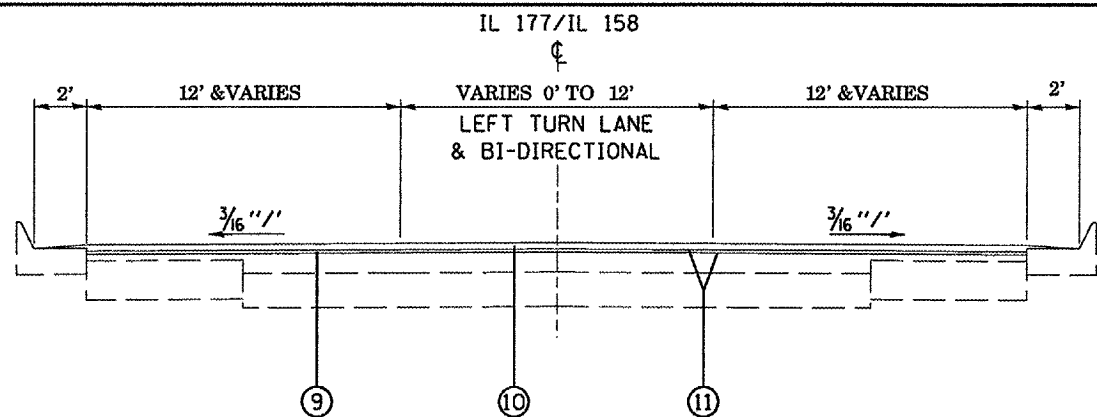

EXISTING TYPICAL SECTION
STA. 100+70 TO STA. 120+50

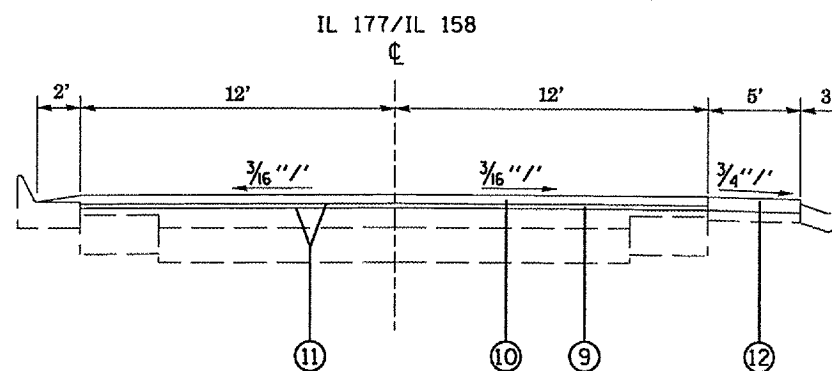

EXISTING TYPICAL SECTION
STA. 130+79 TO STA. 141+00 RT

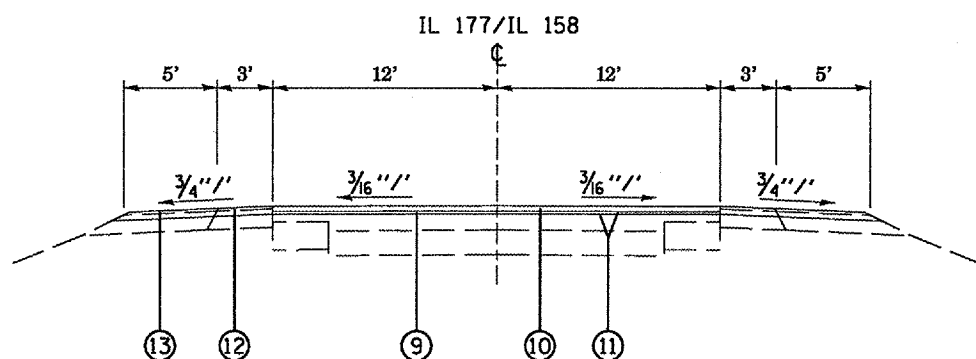

EXISTING TYPICAL SECTION

- STA. 125+80 TO STA. 130+79
- STA. 143+00 TO STA. 148+54
- STA. 148+95 TO STA. 157+80
- STA. 173+65 TO STA. 175+00
- STA. 185+00 TO STA. 213+35
- STA. 253+41 TO STA. 265+75
- STA. 277+82 TO STA. 355+83
- STA. 356+54 TO STA. 394+40

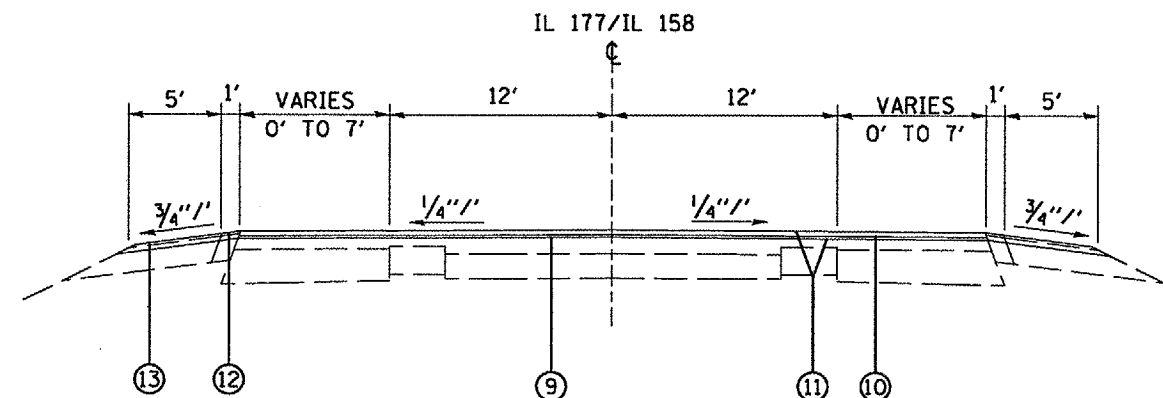

EXISTING TYPICAL SECTION
STA. 213+35 TO STA. 224+80
STA. 228+22 TO STA. 243+46

LEGEND

- ① EXISTING AGGREGATE SHOULDER
- ② EXISTING HMA SHOULDER
- ③ EXISTING TYPE "A" GUTTER
- ④ EXISTING CURB & GUTTER TYPE B-6.24
- ⑤ EXISTING BASE COURSE WIDENING, 9"
- ⑥ EXISTING PORTLAND CEMENT CONCRETE PAVEMENT 7" TO 9" THICK
- ⑦ EXISTING HMA RESURFACING
- ⑧ PROPOSED HMA SURFACE REMOVAL, 1"
- ⑨ PROPOSED HMA LEVEL BINDER, 3/4 "
- ⑩ PROPOSED HMA SURFACE COURSE, 1 1/2 "
- ⑪ PROPOSED AGGREGATE & BITUMINOUS MATERIALS (PRIME COAT)
- ⑫ PROPOSED HMA SHOULDERS 2 1/4"
- ⑬ PROPOSED AGGREGATE SHOULDER, TYPE B
- ⑭ PROPOSED STRIP REFLECTIVE CRACK CONTROL

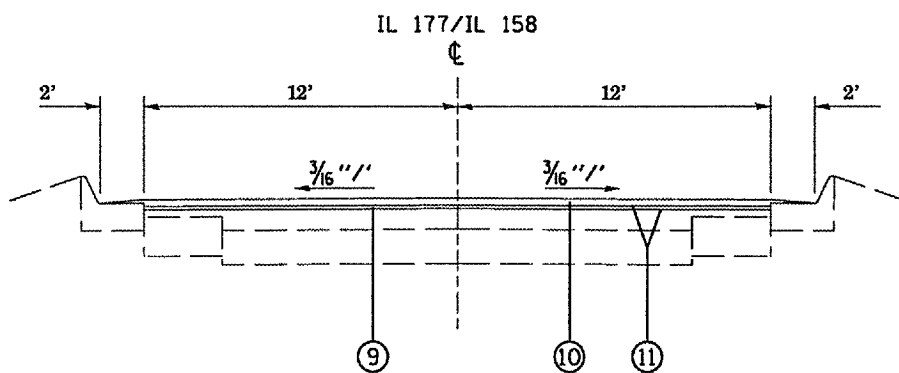

EXISTING TYPICAL SECTION
STA. 120+50 TO STA. 125+80
STA. 130+79 TO STA. 141+00LT
STA. 141+00 TO STA. 143+00

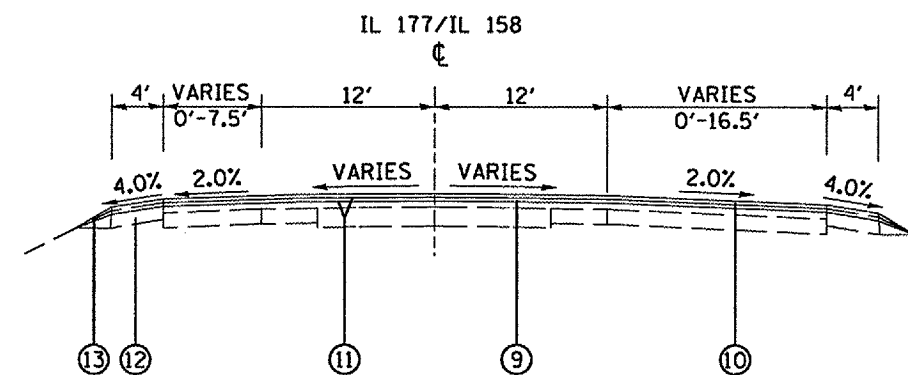

EXISTING TYPICAL SECTION
STA. 265+75 TO STA. 277+82

REVISIONS	
NAME	DATE

ILLINOIS DEPARTMENT OF TRANSPORTATION
PROPOSED TYPICAL SECTIONS

FAU 9251 / FAS 1848 / FAU 9288
SECTION 27RS-2, 28, 29RS-2
ST. CLAIR COUNTY
SCALE: VERT. _____
HORIZ. _____
DATE _____ DRAWN BY _____
CHECKED BY _____