

SECTION A-A

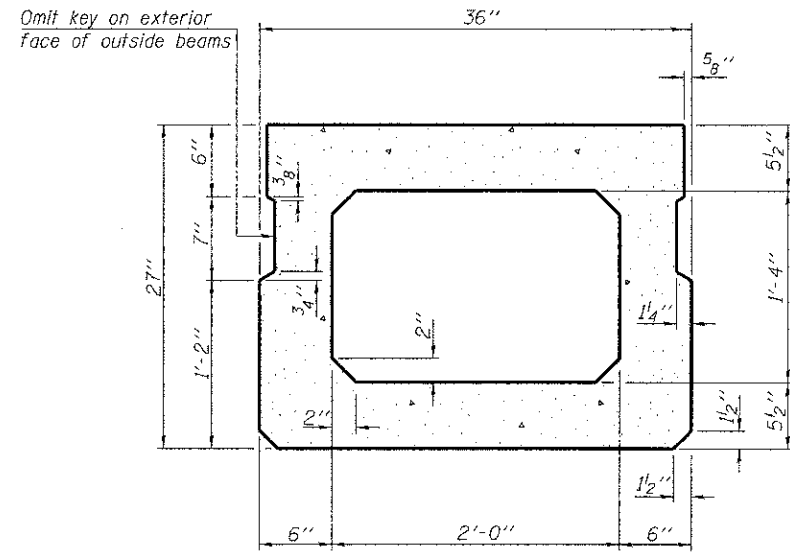

SECTION B-B
(Showing dimensions)

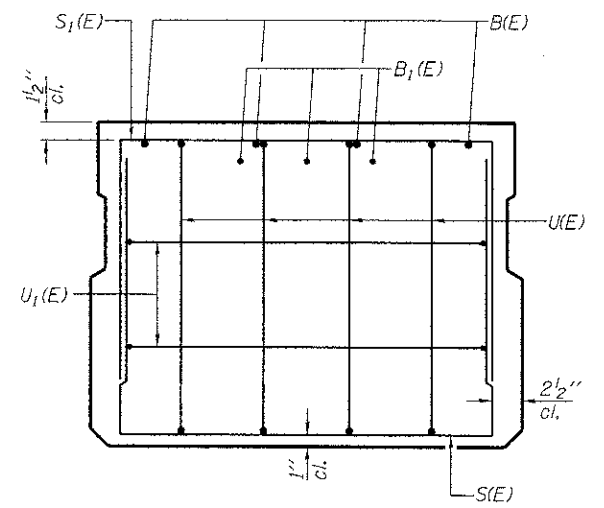

VIEW C-C

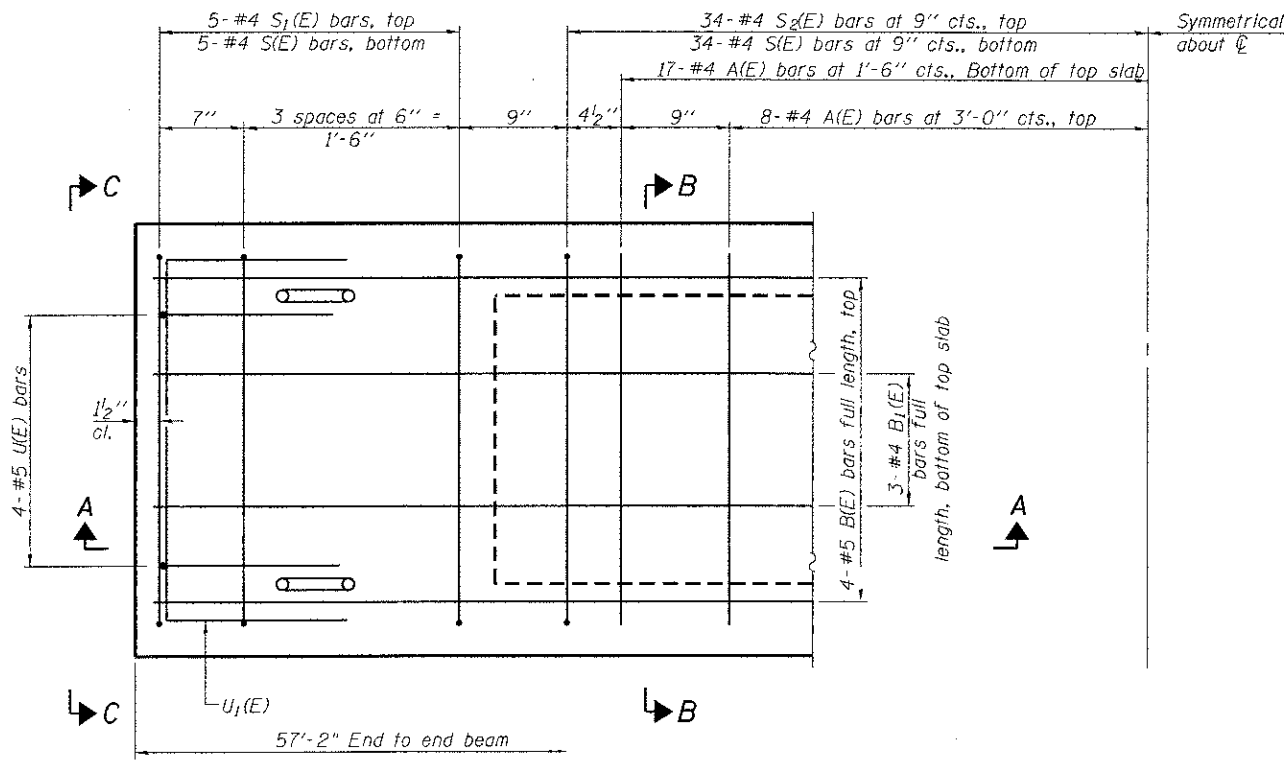

PLAN VIEW

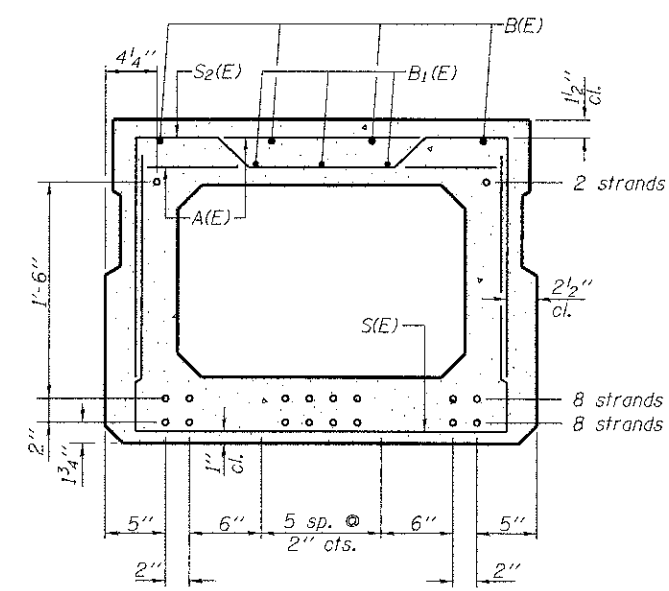

SECTION B-B
(Showing reinforcement and permissible strand locations)
Note: Place the number of strands specified in each row symmetrically about the centerline of beam in the permissible strand locations shown.

BAR LIST
ONE BEAM ONLY
(For information only)

Bar	No.	Size	Length	Shape
A(E)	50	#4	2'-7"	—
B(E)	4	#5	56'-10"	—
B1(E)	3	#4	56'-10"	—
S(E)	78	#4	6'-5"	┌
S1(E)	10	#4	5'-11"	┌
S2(E)	68	#4	6'-2"	┌
U(E)	8	#5	4'-6"	┌
U1(E)	4	#4	5'-0"	┌

Note: See sheet 7 of for additional details and Bill of Material.

MINIMUM BAR LAP

#4 bar = 2'-0"
#5 bar = 2'-6"

Note: Spacing of S(E) and S2(E) bars may be adjusted up to 4" in the immediate area of the transverse tie diaphragms to miss the block outs for the transverse ties.

PD-2736-0

7-1-10

FILE NAME = 0496751-006-Deck Beam36.dgn	USER NAME = jehrhart	DESIGNED - JCE	REVISED -
McDonough Associates Inc. Engineers / Architects 180 North Station Ave., Chicago, Illinois 60601	PLOT SCALE = 1:0.0033333	CHECKED - GEK	REVISED -
	PLOT DATE = 05/14/12	DRAWN - JCE	REVISED -
		CHECKED - GEK	REVISED -

STATE OF ILLINOIS
DEPARTMENT OF TRANSPORTATION

27" x 36" PPC DECK BEAM
STRUCTURE NO. 049-6751
SHEET NO. 6 OF 16 SHEETS

F.A. RTE.	SECTION	COUNTY	TOTAL SHEETS	SHEET NO.
	09-0010-00-BR	LAKE	41	19
CONTRACT NO. 63716			ILLINOIS FED. AID PROJECT	