

08-03-12 LETTING ITEM 058

DESIGNER: CLARK JONES
PHONE: (309)671-3452

PROJECT ENGINEER: MARK ECKHOFF
PHONE: (309)671-4463

STATE OF ILLINOIS
DEPARTMENT OF TRANSPORTATION
DIVISION OF HIGHWAYS
**PROPOSED
HIGHWAY PLANS**

F.A.I. RTE.	SECTION	COUNTY	TOTAL SHEETS	SHEET NO.
74	[90-14HB-1(BR)]I-1	TAZEWELL	17	1
FED. ROAD DIST. NO. 4	ILLINOIS	CONTRACT NO. 68B19		

D-94-065-12

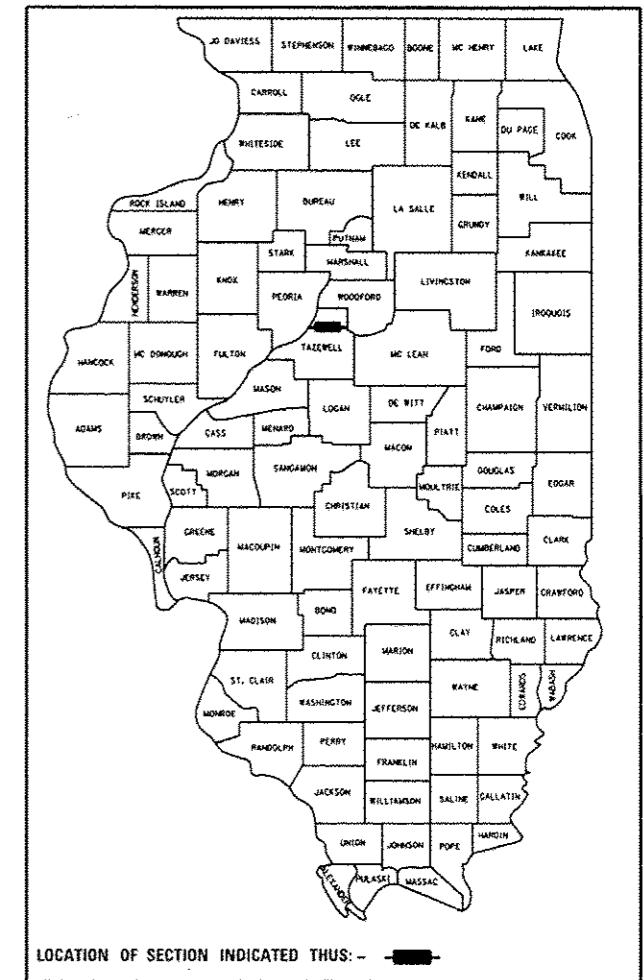

INDEX OF SHEETS:

- 1. COVER SHEET
- 2. COMMITMENTS & GENERAL NOTES
- 3. SUMMARY OF QUANTITIES
- 4. TYPICAL SECTIONS
- 5. SCHEDULE OF QUANTITIES
- 6. GENERAL LAYOUT
- 7-9. PROPOSED TRAFFIC CONTROL
- 10-17. REPAIR DETAILS

FAI 74 (I-74)
SECTION [90-14HB-1(BR)]I-1
(MCHD CLAIM 764511)
TAZEWELL COUNTY
C-94-109-12

R 2W

STANDARDS:

- 701101-02
- 701406-06
- 701601-07

D4 STANDARDS:

- 701901-02
- 780001-03
- 650001-D4

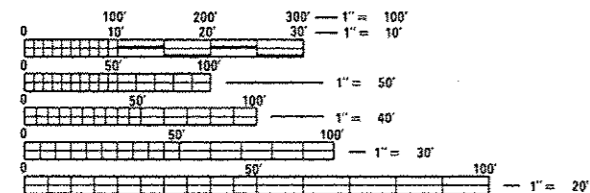

FULL SIZE PLANS HAVE BEEN PREPARED USING STANDARD ENGINEERING SCALES. REDUCED SIZED PLANS WILL NOT CONFORM TO STANDARD SCALES. IN MAKING MEASUREMENTS ON REDUCED PLANS, THE ABOVE SCALES MAY BE USED.

J.U.L.I.E.
JOINT UTILITY LOCATION INFORMATION FOR EXCAVATION
1-800-892-0123
OR 811

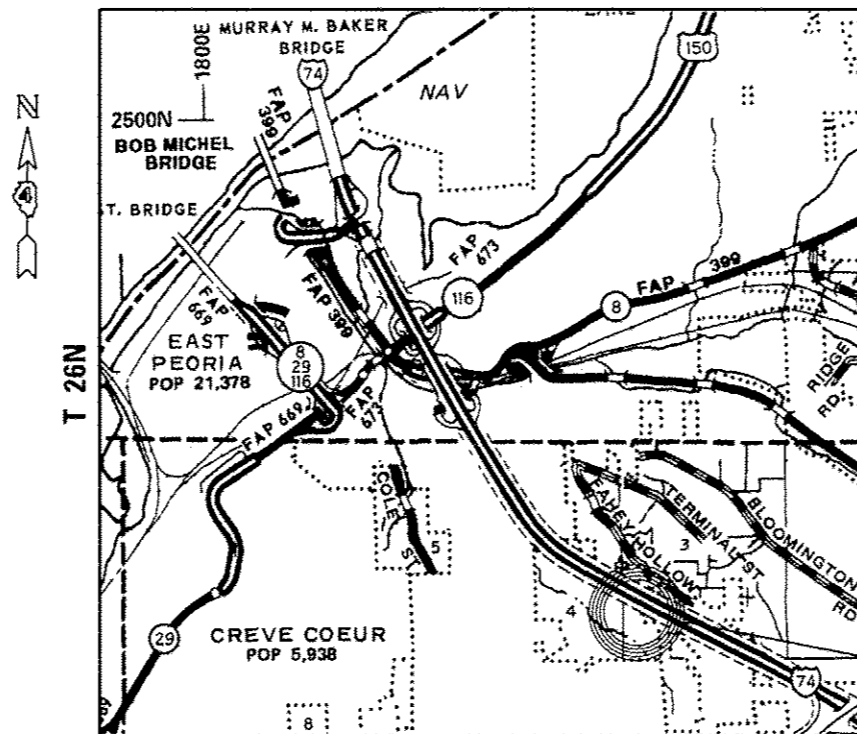

LOCATION MAP

STRUCTURAL STEEL REPLACEMENT, REPAIRS & STRENGTHENING OF BEAMS & PLATES ON SUPERSTRUCTURE OVER WB LANES OF I-74 ON SN.090-0091 PINECREST DR. OVERPASS

SN.090-0091

STATE OF ILLINOIS
DEPARTMENT OF TRANSPORTATION
DIVISION OF HIGHWAYS

SUBMITTED June 20 2012
Joseph E. Crowder
DEPUTY DIRECTOR OF HIGHWAYS, REGION ENGINEER

John D. Baranzelli PE, Ia
actg ENGINEER OF DESIGN AND ENVIRONMENT

June 29 2012
William R. Frey Ia
actg DIRECTOR OF HIGHWAYS, CHIEF ENGINEER

PRINTED BY THE AUTHORITY
OF THE STATE OF ILLINOIS

CONTRACT NO. 68B19 CAT. NO. 034836-00D

COMMITMENTS

Commitments are not to be altered without the written approval of all parties to which the commitment was made.

GENERAL NOTES

ENVIRONMENTAL REVIEWS

Prior to the use of any proposed borrow areas, use areas (temporary access roads, detours, run-arounds, etc.) and/or waste areas, the Contractor shall file the required environmental resource request surveys according to Section 107.22 of the Standard Specifications. These surveys are required in order for the Department to conduct cultural and biological resource surveys for the proposed site.

Prior to any waste materials being removed from the construction site the required environmental resource surveys will need to be obtained and filed by the Contractor. Excess waste products removed from the construction site shall be disposed of as required in Section 202.03 of the Standard Specifications.

Any protruding metal bars shall be removed prior to the disposal of broken concrete at approved disposal sites.

The required environmental resource documentation shall include the following:

- * BDE Form 2289 (Environmental Survey Request)
- * A location map showing the size limits and location of the use area
- * Signed property owner agreement form-D4 PI0100
- * Color photographs depicting the use area
- * Borrow Area Entry Agreement form-D4 PI0101

Please note that a minimum of two weeks shall be allowed for the District to obtain the required environmental clearances.

No field welding is permitted except as specified in the contract documents.

All structural steel shall be AASHTO M 270 Grade 36 (except expansion joints which shall be AASHTO M 270 Grade 50.)

Reinforcement bars shall conform to the requirements of ASTM A 706 Gr 60 (IL Modified). See Special Provisions

JOB SPECIFIC NOTES

Included in the scope of this project after steel work is complete, is the replacement of all Protective Shield components that have been damaged or removed from the superstructure during this or previous beam repairs above EB and WB lanes. Any protruding fastener items on existing shielding shall be removed and replaced to produce a smooth, safe working platform. Cost included with BEAM STRAIGHTENING. Work to be coordinated at least one week in advance with Bridge Maintenance Engineer Mark Eckhoff at I.D.O.T. Operations Dept. Ph. (309) 671-4463.

The Contractor shall be required to verify existing steel beam lengths prior to ordering new replacement steel for the project.

PERMANENT PROTECTIVE SHIELDING BILL OF MATERIALS

SN	Roadway	Feature Crossed	Roadway Description	County	Shield Coverage	Beam Spacing	Bridge Width	Skew Angle	Shield Size
090-0091	Pinecrest	I-74	(2' Shldr. + 24' lanes + 2' Shldr.) x2	Tazewell	56 bays	5.8'	291'	16.62°	195 Sq.Yd.

S:\GEN-DRAFT-ST&PLNS-SQUEBRIDGES-CONTRACTS-STEEL BEAM REP-68819 SN090-0091-SN090-0091 PinecrestDr.ovr1-74.dgn

FILE NAME =	USER NAME = jonasa	DESIGNED - CEJ	REVISED -	STATE OF ILLINOIS DEPARTMENT OF TRANSPORTATION	SUMMARY OF QUANTITIES PINECREST DRIVE OVER F.A.I. ROUTE 74 SN 090-0091			F.A.I. RTE.	SECTION	COUNTY	TOTAL SHEETS	SHEET NO.
S:\GEN-DRAFT-ST&PLNS-SQUEBRIDGES-CONTRACTS-STEEL BEAM REP-68819 SN090-0091-SN090-0091 PinecrestDr.ovr1-74.dgn		CHECKED -	REVISED -		74	[90-14HB-1(BR)]-1	TAZEWELL	2				
PLOT SCALE = 1/8" = 1' / in.		DATE - 06/15/2012	REVISED -		STEEL BEAMS REP./REPL.	CONTRACT NO. 68819						
PLOT DATE = 6/29/2012					FED. ROAD DIST. NO. 4 ILLINOIS FED. AID PROJECT							

URBAN
100% STATE

CONST. CODE

0014

TAZEWELL

COUNTY

MCHD 764511

CODE NO.	ITEM	UNIT	TOTAL QUANTITY	
50102400	CONCRETE REMOVAL	CUYD	1.3	1.3
50300255	CONCRETE SUPERSTRUCTURE	CUYD	1.3	1.3
50500405	FURNISHING AND ERECTING STRUCTURAL STEEL	POUND	11,890	11,890
67100100	MOBILIZATION	LSUM	1	1
70100700	TRAFFIC CONTROL AND PROTECTION, STANDARD 701406	LSUM	1	1
70102630	TRAFFIC CONTROL AND PROTECTION, STANDARD 701601	LSUM	1	1
70106800	CHANGEABLE MESSAGE SIGN	CALMO	1	1
X 70300520	PAVEMENT MARKING TAPE, TYPE III 4"	FOOT	1400	1400
70301000	WORKZONE PAVEMENT MARKING REMOVAL	SQFT	467	467
X 78005110	EPOXY PAVEMENT MARKING-LINE 4"	FOOT	2392	2392
78300100	PAVEMENT MARKING REMOVAL	SQFT	800	800
X0323583	SPEED INDICATOR SIGN	CALDA	70	70
Z0001903	STRUCTURAL STEEL REMOVAL	POUND	12,060	12,060
Z0001905	STRUCTURAL STEEL REPAIR	POUND	2080	2080
Z0003600	BEAM STRAIGHTENING	LSUM	1	1
Z0030240	IMPACT ATTENUATORS, TEMPORARY (NON-REDIRECTIVE), TEST LEVEL 2	EACH	1	1
Z0073300	TEMPORARY SHORING AND CRIBBING	LSUM	1	1
Z0073351	TEMPORARY SLAB SUPPORT SYSTEM	LSUM	1	1

X SPECIALTY
ITEM

S:\GEN-DRAFT-STD&PLNS-SCUDDBRIDGES-BRIDGE CONTRACTS-STEEL BEAM REP-68819 SN090-0091-SN090-0091-PinecrestDr-ovr1-74.dgn

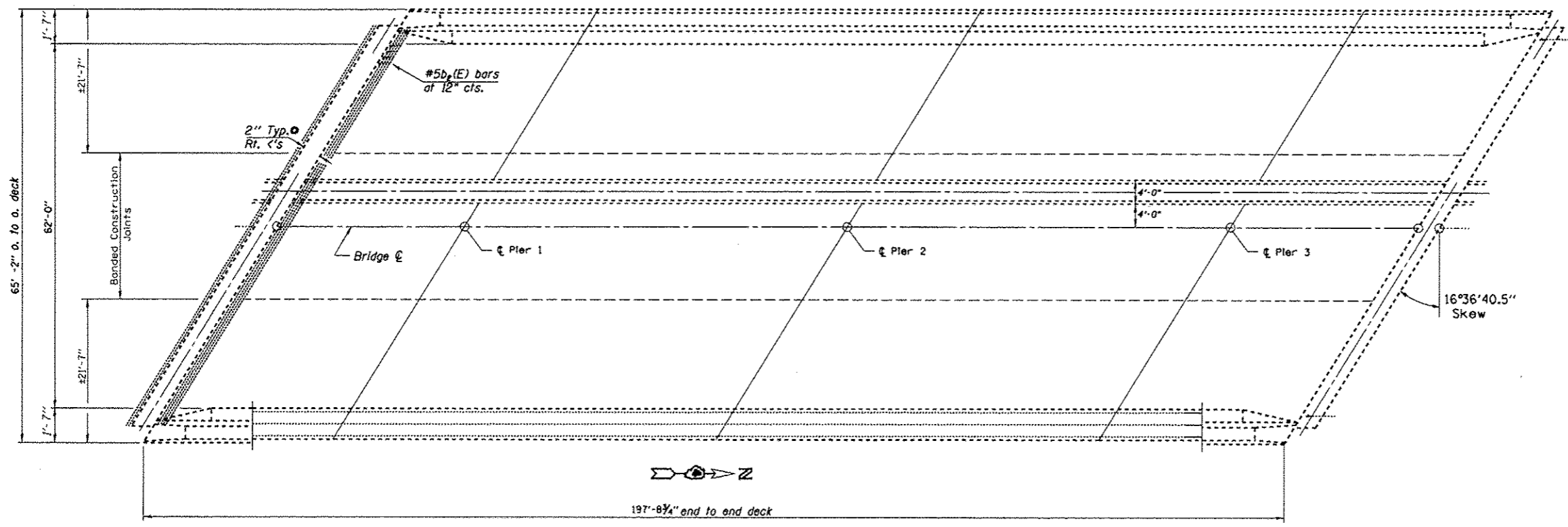

EXISTING DECK

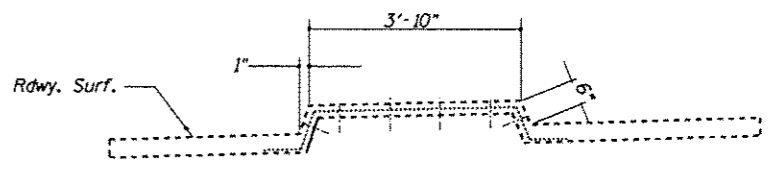

TYPE S.B. 6.12 MEDIAN

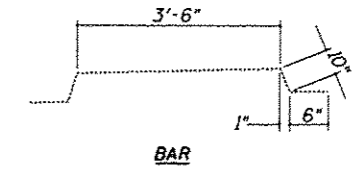

BAR

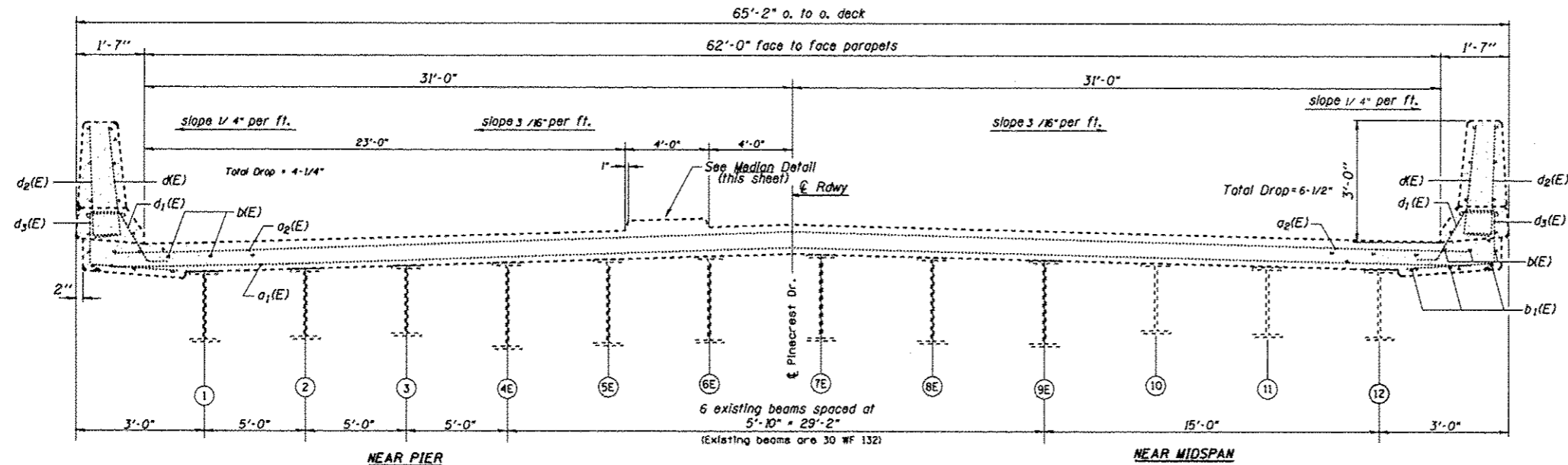

EXISTING CROSS SECTION
(Looking NORTH)

FILE NAME :	USER NAME : jonesce	DESIGNED - CEJ	REVISED -	STATE OF ILLINOIS DEPARTMENT OF TRANSPORTATION	DECK PLAN & CROSS SECTION PINECREST DRIVE OVER F.A.I. ROUTE 74 SN 090-0091		F.A.I. RTE. 74	SECTION [90-14HB-(BR)]-1	COUNTY TAZEWELL	TOTAL SHEETS 17	SHEET NO. 4
S:\GEN-DRAFT-STD&PLNS-SCUDDBRIDGES-BRIDGE CONTRACTS-STEEL BEAM REP-68819 SN090-0091-SN090-0091-PinecrestDr-ovr1-74.dgn	BRIDGE CONTRACTS-STEEL BEAM REP-68819 SN090-0091-SN090-0091-PinecrestDr-ovr1-74.dgn	DRAWN TO 08% Strength	REVISED -		SCALE: _____	SHEET NO. _____ OF _____ SHEETS	STA. _____ TO STA. _____	STEEL BEAMS REP./REPL.	CONTRACT NO. 68819	FED. ROAD DIST. NO. 4	ILLINOIS FED. AID PROJECT
PLOT SCALE : 1/8" = 1' / in.	CHECKED -	DATE - 06/15/2012	REVISED -								
PLOT DATE : 6/20/2012											

SCHEDULE OF QUANTITIES

CONCRETE REMOVAL

LOCATION	CUYD
AS SHOWN ON DETAIL SHEETS	1.3
TOTAL	1.3

PVMT. MRKG. TAPE, TYPE III 4"

LOCATION	FOOT
AS SHOWN ON TRAFFIC SHEETS	1400
TOTAL	1400

STRUCTURAL STEEL REMOVAL

LOCATION	POUND
EB. LANES AS SHOWN ON DETAIL SHEETS	12,060
TOTAL	12,060

TEMPORARY SLAB SUPPORT SYSTEM

LOCATION	LSUM
PROJECT DECK LOCATIONS	1
TOTAL	1

CONCRETE SUPERSTRUCTURE

LOCATION	CUYD
AS SHOWN ON DETAIL SHEETS	1.3
TOTAL	1.3

WORKZONE PAVEMENT MARKING REMOVAL

LOCATION	SQFT
AS SHOWN ON TRAFFIC SHEETS	467
TOTAL	467

STRUCTURAL STEEL REPAIR

LOCATION	POUND
WB. LANES AS SHOWN ON DETAIL SHEETS	2080
TOTAL	2080

FURNISHING & ERECTING STRUCTURAL STEEL

LOCATION	POUND
AS SHOWN ON DETAIL SHEETS	11,890
TOTAL	11,890

EPOXY PAVEMENT MARKING-LINE 4"

LOCATION	FOOT
AS REQUIRED BY T.C.& P	2392
TOTAL	2392

BEAM STRAIGHTENING

LOCATION	LSUM
PROJECT BEAM LOCATIONS	1
TOTAL	1

MOBILIZATION

LOCATION	LSUM
PROJECT LOCATION	1
TOTAL	1

PAVEMENT MARKING REMOVAL

LOCATION	SQFT
AS REQUIRED BY T.C.& P	800
TOTAL	800

IMPACT ATTENUATORS, NRD, TL2

LOCATION	EACH
SPAN 3 OF BRIDGE DECK	1
TOTAL	1

TRAFFIC CONTROL AND PROTECTION

LOCATION	T.C.&P. STANDARD 701406 (LSUM)	T.C.&P. STANDARD 701601 (LSUM)	SPEED INDICATOR SIGN (CAL DA)	CHANGEABLE MESSAGE SIGN (CAL MO)
PINECREST BRIDGE OVERPASS I-74 PROJECT LANES	1	1	70	1
TOTAL	1	1	70	1

TEMPORARY SHORING AND CRIBBING

LOCATION	LSUM
PROJECT BEAM LOCATIONS	1
TOTAL	1

S:\GEN-DRAFT-STD&PLNS-Squad\BRIDGES-BRIDGE CONTRACTS-STEEL BEAM REP-68B19 SN090-0091-SN.090-0091 PinecrestDr.ovr1-74.dgn

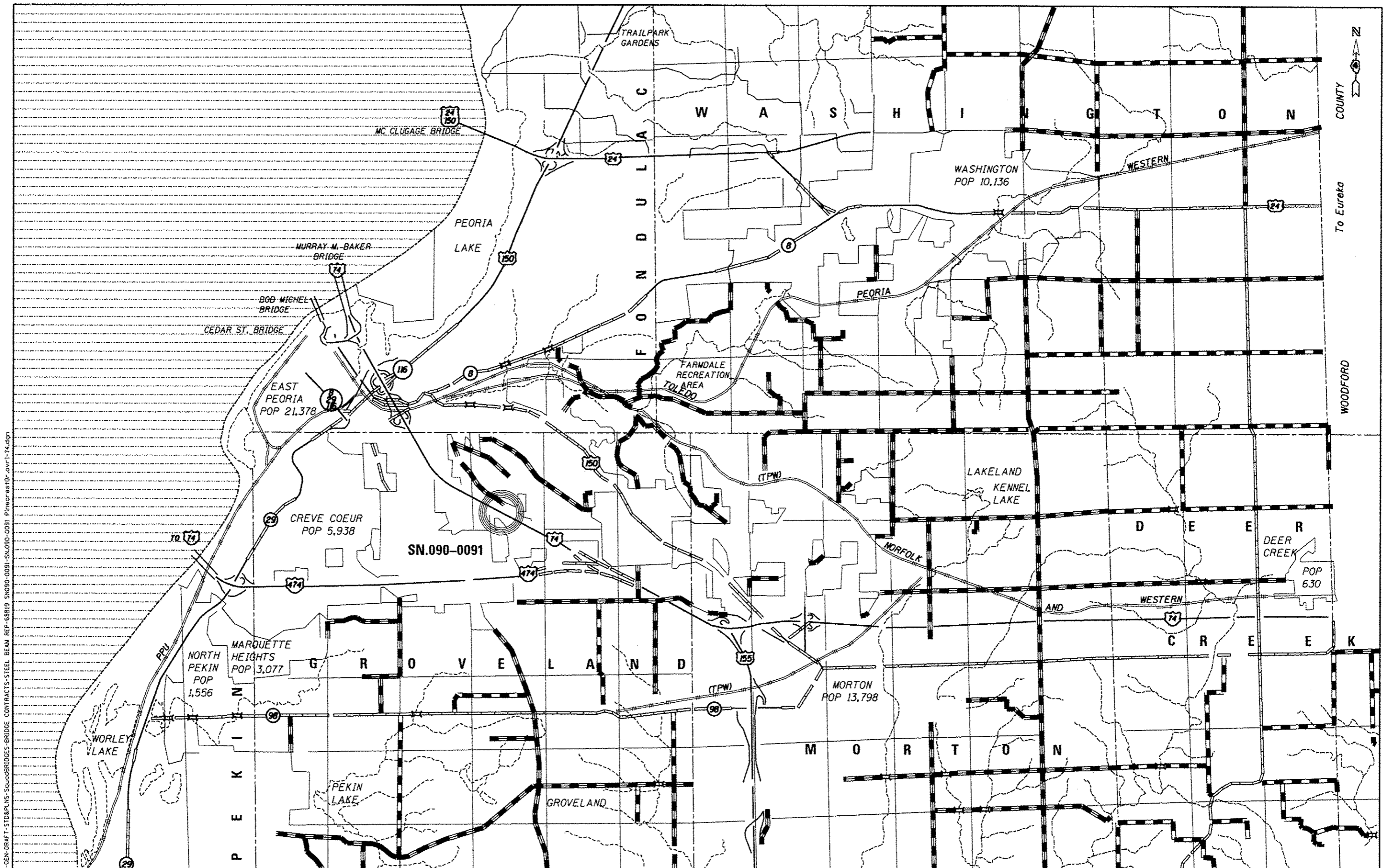

S:\GEN-DRAFT-STDA\PLNS-Squad\BRIDGES-BRIDGE CONTRACTS-STEEL BEAM REP-68819 SN090-0091-SN.090-0091-PinecrestDr.dwg 1-14.dgn

FILE NAME :	USER NAME : jonesca	DESIGNED - CEJ	REVISED -	STATE OF ILLINOIS DEPARTMENT OF TRANSPORTATION		GENERAL LAYOUT		F.A.I. RTE.	SECTION	COUNTY	TOTAL SHEETS	SHEET NO.
S:\GEN-DRAFT-STDA\PLNS-Squad\BRIDGES-BRIDGE CONTRACTS-STEEL BEAM REP-68819 SN090-0091-SN.090-0091-PinecrestDr.dwg	PLDT SCALE = 1/8" = 1' / in.	CHECKED -	REVISED -			PINECREST DRIVE OVER F.A.I. ROUTE 74		74	(90-14HB-1BR1)-1	TAZEWELL	17	6
PLDT DATE = 6/29/2012	DATE = 06/15/2012	REVISED -	REVISED -			SN 090-0091		STEEL BEAMS REP./REPL.		CONTRACT NO. 68819		
						SCALE: _____ SHEET NO. ____ OF ____ SHEETS STA. _____ TO STA. _____		FED. ROAD DIST. NO. 4 ILLINOIS FED. AID PROJECT				

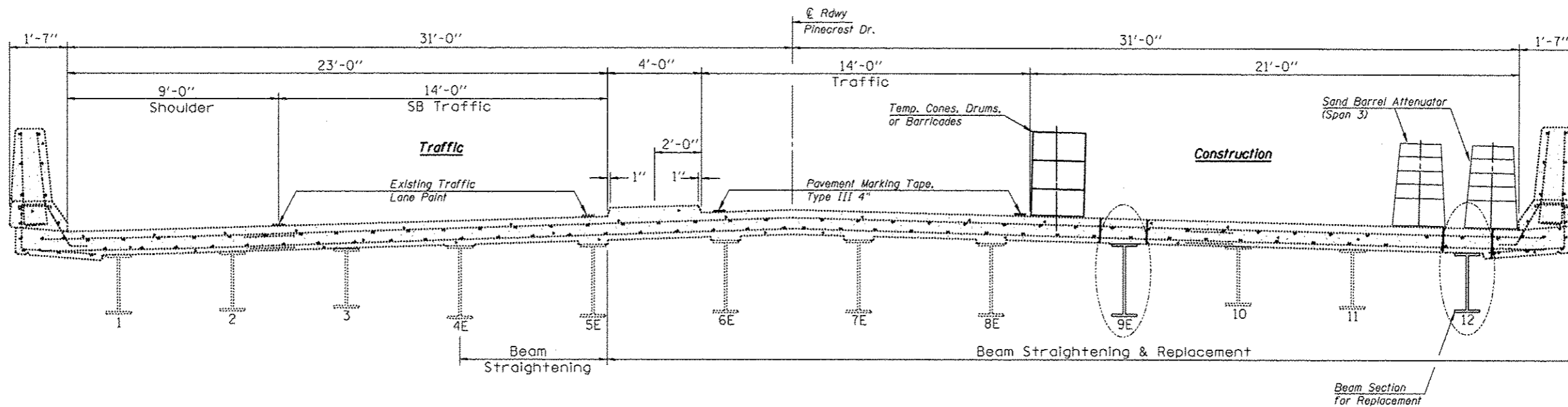

CROSS SECTION
(Stage I
Looking North)

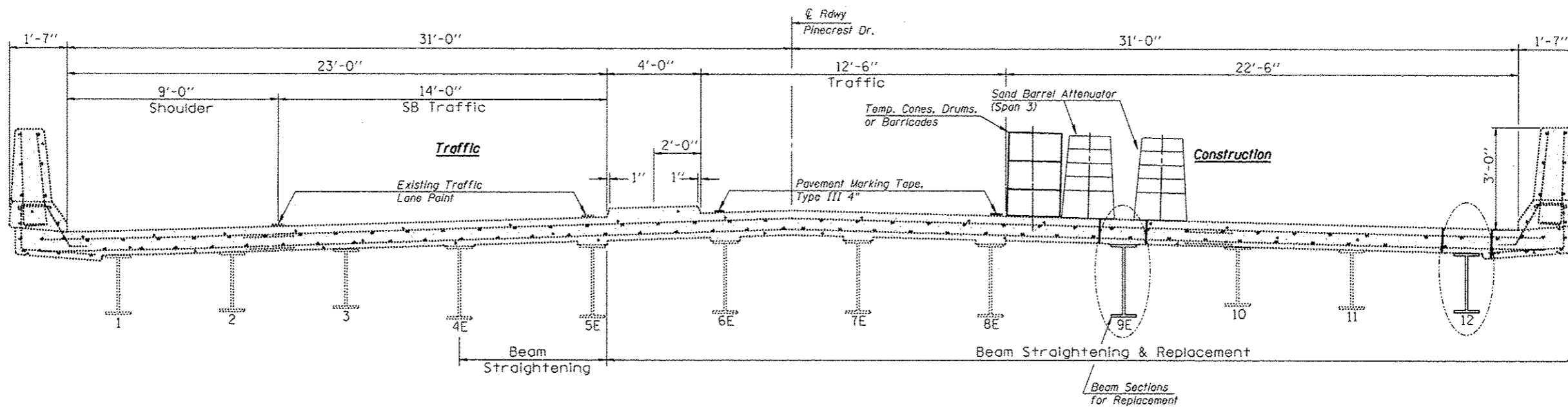

CROSS SECTION
(Stage II
Looking North)

SYMBOLS

- Cones, Drums, or Barricades
- Pavement Marking Tape Type III, 4"
- Sand Barrel Attenuator

NOTES

Refer to Highway Standards 701406 & 701601 in conjunction with this sheet for exact placement of traffic management devices and other clarifications as construction staging symbols and dimensioning were duplicated off of these standards.
Temporary Pavement Marking Tape, Type III 4" shall be placed throughout the taper and alongside the work area as shown in the plans.

S:\GEN-DRAFT-STD&PLNS-Squad\BRIDGES-CONTRACTS-STEEL BEAM REP-68819 SN090-0091 PinecrestDr.ovr1-74.dgn

FILE NAME :	USER NAME : jonesc	DESIGNED - CEJ	REVISED -	STATE OF ILLINOIS DEPARTMENT OF TRANSPORTATION	PROPOSED TRAFFIC CONTROL PINECREST DRIVE OVER F.A.I. ROUTE 74 SN 090-0091	F.A.I. RTE.	SECTION	COUNTY	TOTAL SHEETS	SHEET NO.
S:\GEN-DRAFT-STD&PLNS-Squad\BRIDGES-CONTRACTS-STEEL BEAM REP-68819 SN090-0091 PinecrestDr.ovr1-74.dgn	PLANNED - 06/15/2012	CHECKED -	REVISED -			74	[90-14HB-1(BR)]-1	TAZEWELL	7	7
PLOT SCALE = 1/8" = 1' - 0"	DATE - 06/15/2012	CHECKED -	REVISED -			STEEL BEAMS REP./REPL.		CONTRACT NO. 68819		
PLOT DATE = 6/20/2012						FED. ROAD DIST. NO. 4	ILLINOIS	FED. AID PROJECT		





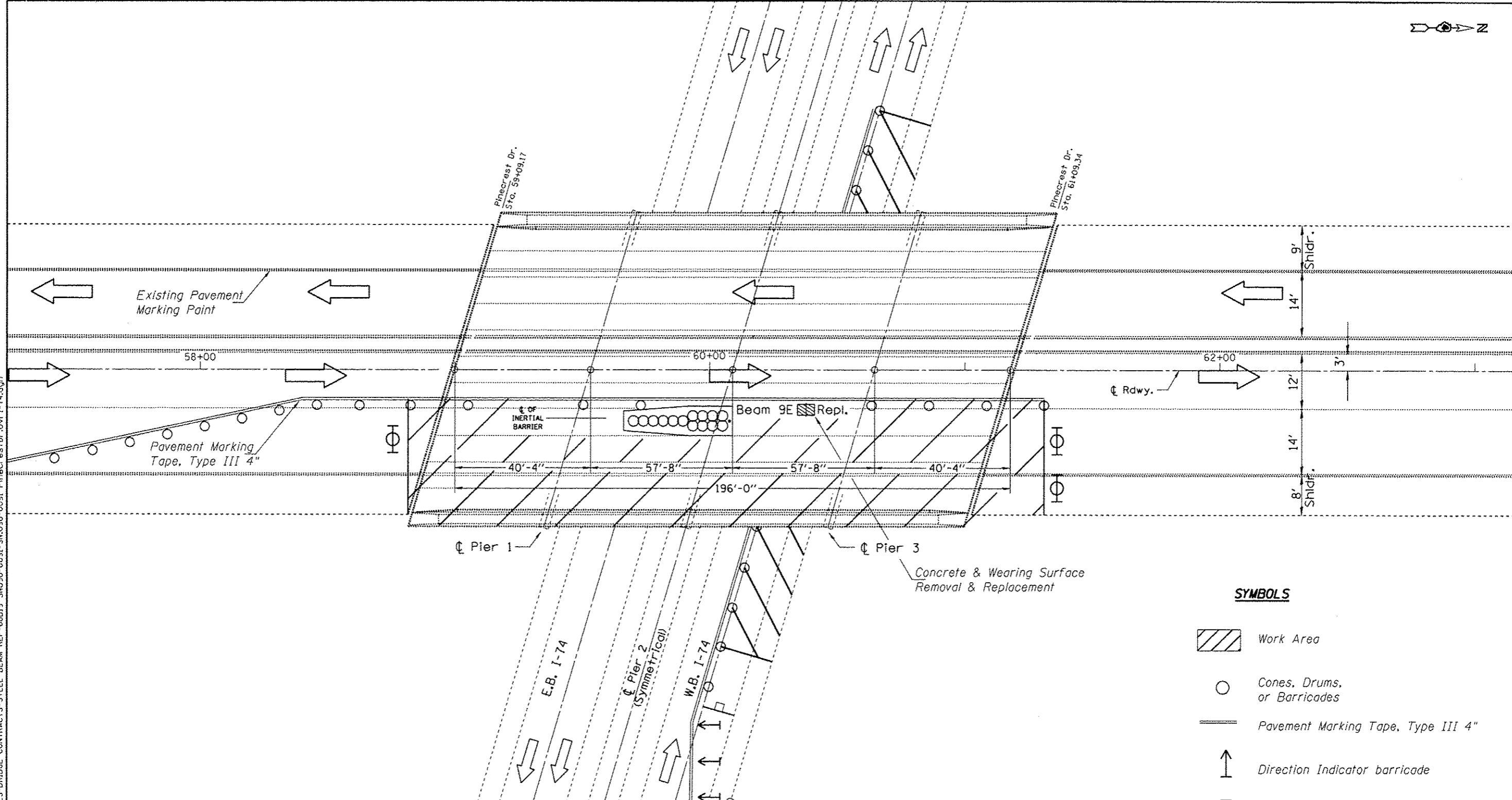



S:\GEN-DRAFT-STO&PLNS-Squad\BRIDGES-BRIDGE CONTRACTS-STEEL BEAM REP-68819 SN090-0091-PinecrestDr.ovr1-74.dgn



PLAN
(Stage II)

SYMBOLS

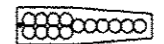
-  Work Area
-  Cones, Drums, or Barricades
-  Pavement Marking Tape, Type III 4"
-  Direction Indicator barricade
-  Barricade or drum w/flashing light
-  Sign (speed indicator)
-  Impact Atten. Temp. NRD, TL2

NOTES:
 Refer to Highway Standards 701406 & 701601 in conjunction with this sheet for exact placement of traffic management devices and other clarifications as construction staging symbols and dimensioning were duplicated off of these standards.
 A Changeable Message Sign shall be used for and located prior to the I-74 lane reduction at least 3 days in advance of work beginning for public notification.
 Speed Indicator Signs shall be required and activated for each closed lane on I-74.

FILE NAME =	USER NAME = jones	DESIGNED - CEJ	REVISED -	STATE OF ILLINOIS DEPARTMENT OF TRANSPORTATION	PROPOSED TRAFFIC CONTROL PINECREST DRIVE OVER F.A.I. ROUTE 74 SN 090-0091		F.A.I. RTE. 74	SECTION (90-14HB-1BR)II-1	COUNTY TAZEWELL	TOTAL SHEETS 17	SHEET NO. 9	
S:\GEN-DRAFT-STO&PLNS-Squad\BRIDGES-BRIDGE CONTRACTS-STEEL BEAM REP-68819 SN090-0091-PinecrestDr.ovr1-74.dgn	DESIGNED - CEJ	CHECKED -	REVISED -		SCALE: _____	SHEET NO. _____ OF _____ SHEETS	STA. _____ TO STA. _____	STEEL BEAMS REP./REPL.	CONTRACT NO. 68819	FED. ROAD DIST. NO. 4 ILLINOIS FED. AID PROJECT		
PLOT SCALE = 1/8" = 1' / in.	CHECKED -	DATE - 06/15/2012	REVISED -									
PLOT DATE = 6/20/2012	CHECKED -	DATE - 06/15/2012	REVISED -									

GENERAL NOTES

All structural steel shall conform to AASHTO Classification M-270 Gr. 36, unless otherwise noted.

Fasteners shall be high strength bolts. Flange splice holes shall be $1\frac{1}{16}$ " ϕ for $7\frac{1}{8}$ " ϕ bolts. Web splice holes shall be $1\frac{3}{16}$ " ϕ for $3\frac{1}{4}$ " ϕ bolts.

After the new beam is in its final position and/or beam straightening operations have been completed, the Engineer in the field shall check to see that the top flange is tight against the slab. If not, the Contractor shall inject epoxy between the existing concrete deck and the top flange of the beam. See Special Provision "Epoxy Injection".

Plan dimensions and details relative to existing plans are subject to nominal construction variations. The Contractor shall field verify existing dimensions and details affecting new construction and make necessary approved adjustments prior to construction or ordering of materials. Such variations shall not be cause for additional compensation for a change in scope of the work, however, the Contractor will be paid for the quantity actually furnished at the unit price bid for the work.

The existing structural steel coating contains lead. The Contractor shall take appropriate precautions to deal with the presence of lead on this project.

Existing structural steel that will be in contact with new structural steel shall be cleaned and painted prior to erection as required by the Special Provision "Cleaning and Painting Contact Surface Areas of Existing Steel Structures".

The Contractor shall provide support and/or shoring systems for the slab and beam in the area of existing beam removal. See Special Provisions "Temporary Shoring and Cribbing" and "Temporary Slab Support System."

Cost of removal and re-installation of all members necessary to complete the work as detailed on the plans and as specified in the Special Provisions shall be included with Furnishing and Erecting Structural Steel.

The Inorganic Zinc Rich Primer / Acrylic / Acrylic Paint System shall be used for shop and field painting of new structural steel except where otherwise noted. The color of the final finish coat for all interior steel surfaces shall be gray, Munsell No. 5B 7/1. The color of the final finish coat for the exterior and bottom flange of the fascia beams shall be Blue, Munsell No. 10B 3/6. See Article 506 of the Standard Specifications.

Load carrying components designated "NTR" shall conform to the Supplemental Requirements for Notch Toughness, Zone 2.

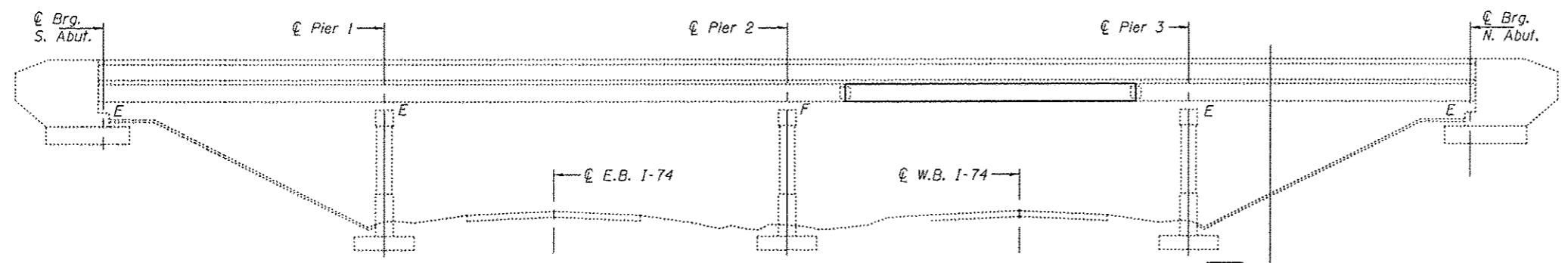

ELEVATION

Temporary shoring may be required to facilitate alignment of existing splice. Use 12" x 12" Timbers or HP's to be paid for as Temporary Shoring and Cribbing. Remove and replace slopewall, if required. Cost included with Temporary Shoring and Cribbing.

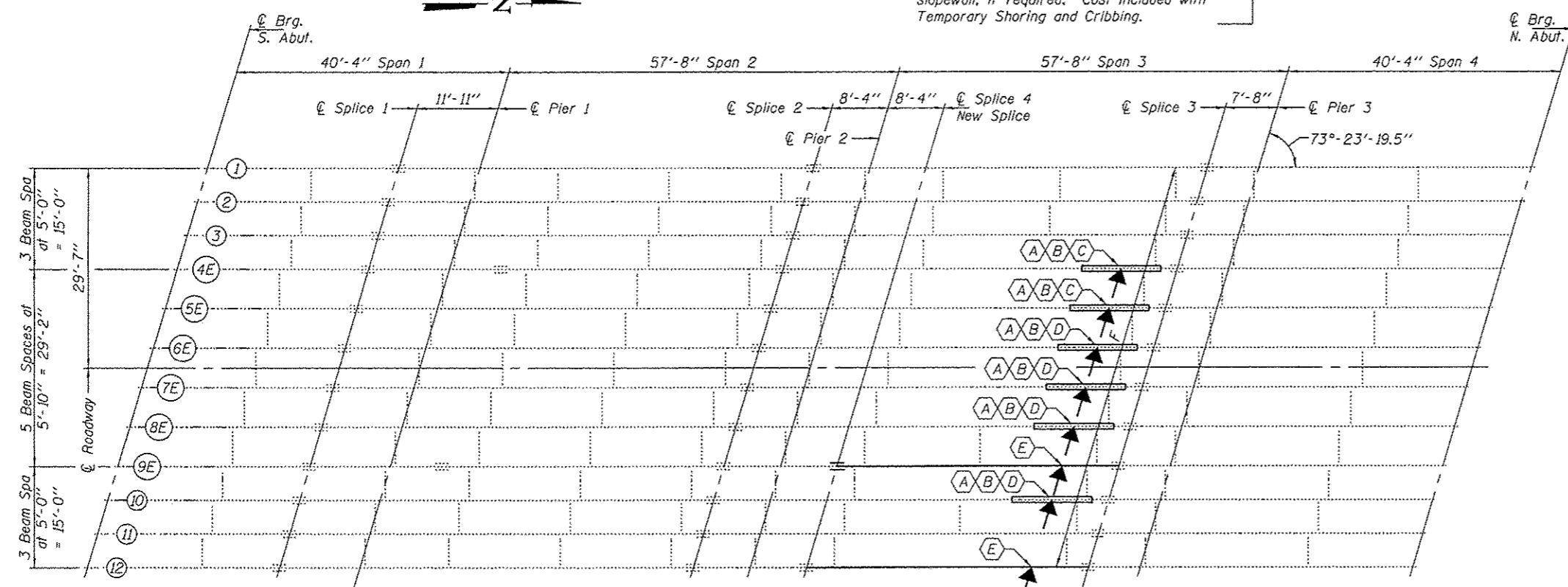

PLAN

- (A) - Existing beam to be straightened.
- (B) - Gouges & nicks to be ground.
- (C) - Existing strengthening plates to be removed & replaced.
- (D) - Existing beam to be strengthened.
- (E) - Existing beam to be removed & replaced.
- (F) - Existing permanent protection shield to be removed & reinstalled to facilitate work. Cost included with Structural Steel Repair or Beam Straightening.

TABLE OF IMPACT LOCATIONS

BEAM	DIM.
4E	6'-7 $\frac{1}{2}$ "
5E	7'-9"
6E	8'-3"
7E	8'-7"
8E	8'-10"
9E	8'-10"
10	9'-2"
12	9'-1 $\frac{1}{2}$ "

TOTAL BILL OF MATERIAL

ITEM	UNIT	QUANTITY
Concrete Removal	Cu. Yd.	1.3
Concrete Superstructure	Cu. Yd.	1.3
Structural Steel Removal	Pound	12,060
Structural Steel Repair	Pound	2080
Furnishing and Erecting Structural Steel	Pound	11,890
Beam Straightening	L.S.	1
Temporary Slab Support System	L.S.	1
Temporary Shoring and Cribbing	L.S.	1

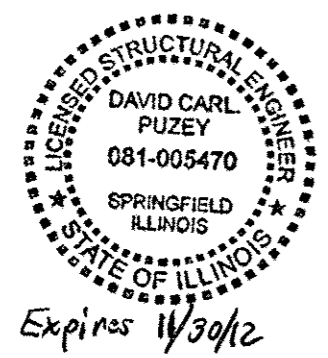

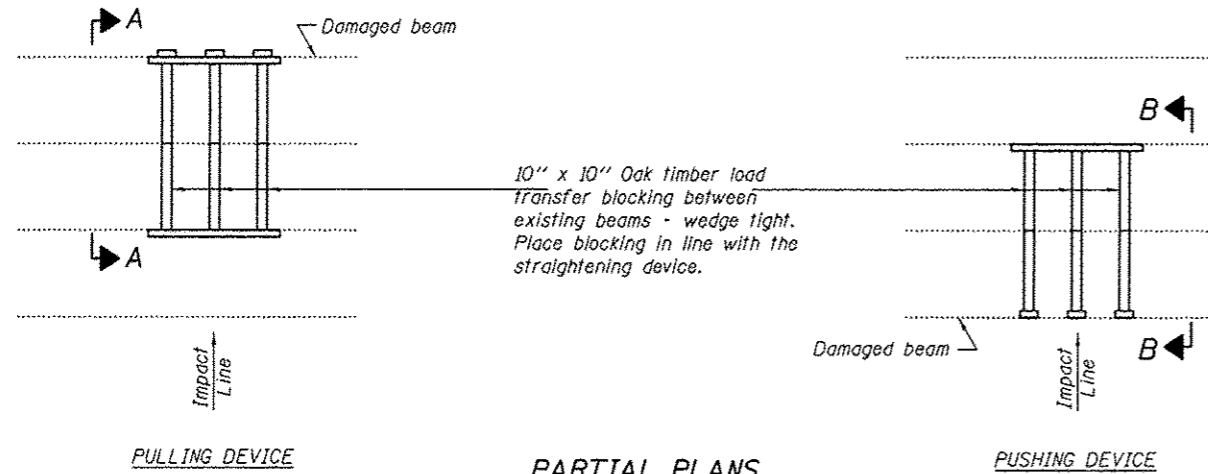

PARTIAL PLANS
SUGGESTED BEAM STRAIGHTENING METHODS
 Straightening force shall be maintained on all load transfer blocking during beam straightening.

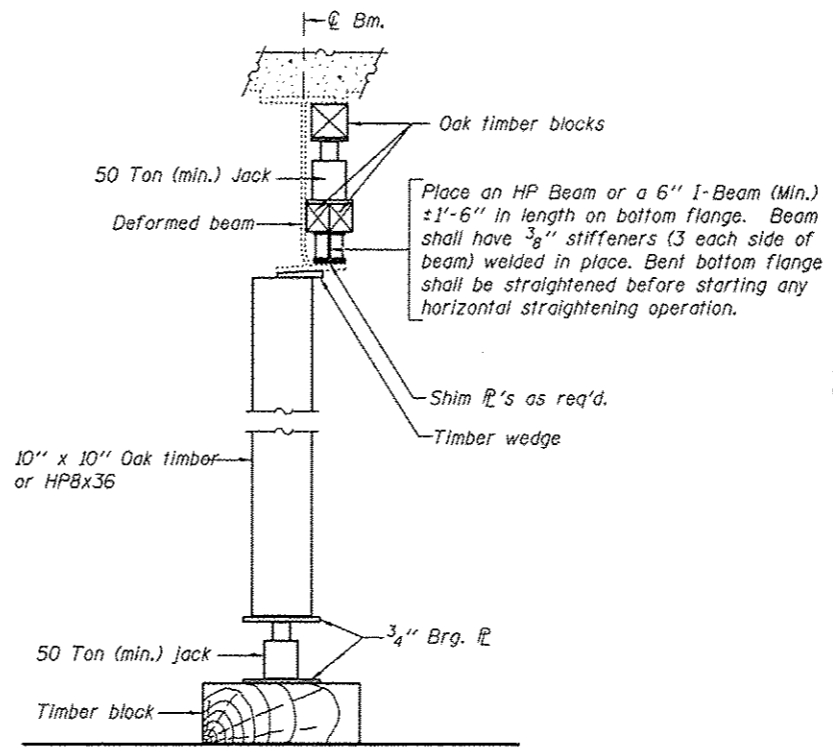

SUGGESTED VERTICAL STRAIGHTENING DETAIL
 (To correct flange rotation.)

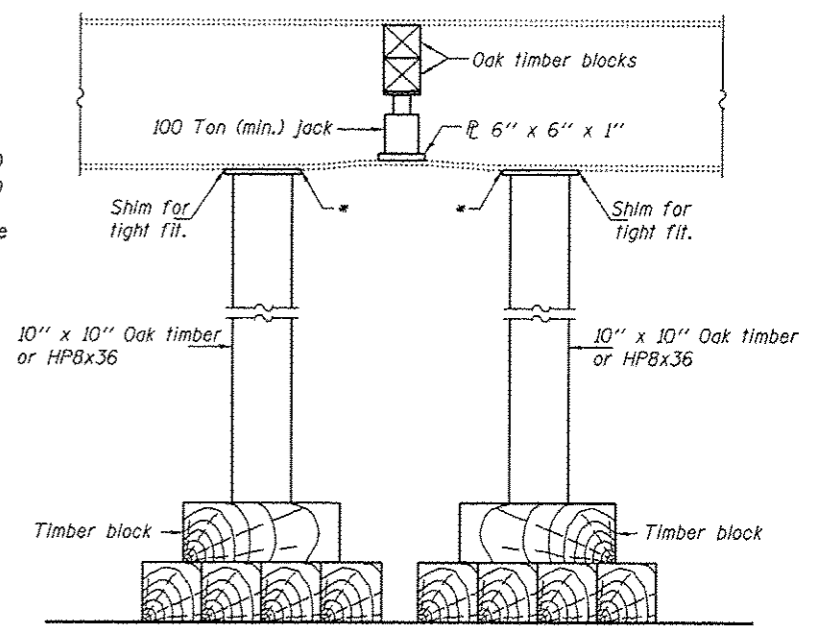

SUGGESTED VERTICAL STRAIGHTENING DETAIL
 (To correct localized vertical flange deformations.)

* Edge of plate shall line up with edge of deformation.
 Note:
 Braces and jack assembly shall be placed on same side of web.
 Bent bottom flange shall be straightened before starting any horizontal straightening operations.

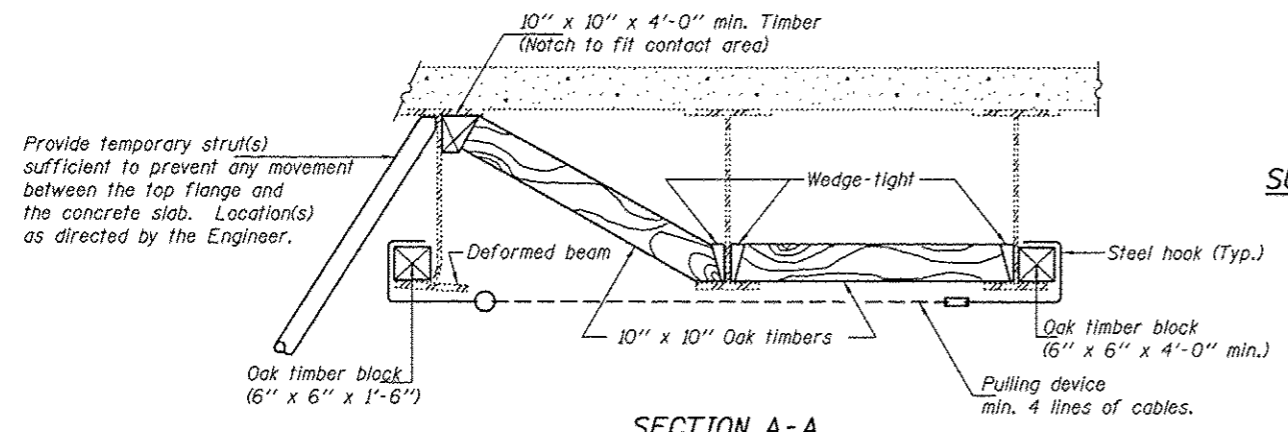

SECTION A-A

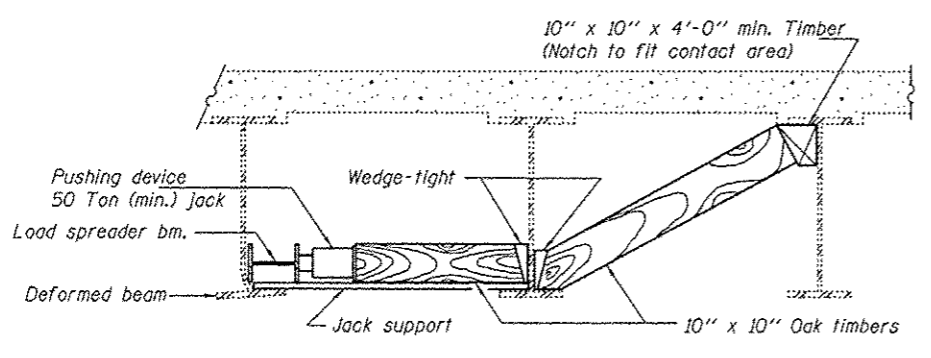

SECTION B-B

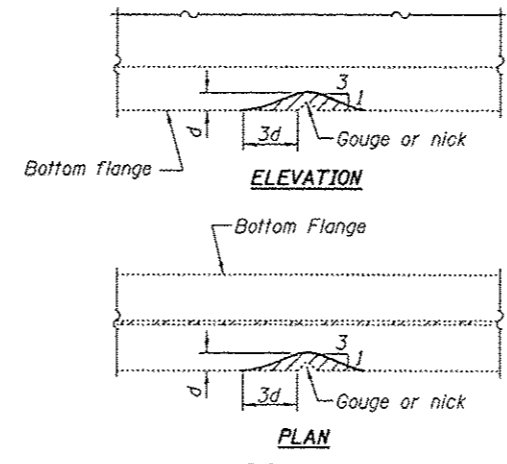

GRINDING DETAIL

Grind existing nicks, gouges and shallow cracks in the damaged beams as detailed. Ground surfaces shall be inspected for cracks using magnetic particle testing prior to initiating any beam straightening operations. Any cracks that cannot be removed by grinding approximately 1/4" deep shall be identified and reported to the Bureau of Bridges and Structures for further disposition. Ground surfaces shall be spot cleaned and painted with an aluminum epoxy mastic primer followed by a finish coat to match the color of the existing beam. Cost of grinding, testing and spot painting included with Beam Straightening.

TABLE OF DIMENSIONS

BEAM	Dim. X	Dim. Y	Dim. L
4E	1/4"	1/16"	6'-0"
5E	1/8"	1/4"	6'-6"
6E	7/8"	2 3/8"	6'-0"
7E	3/8"	1 13/16"	2'-0"
8E	1/2"	1/8"	7'-6"
10	1/16"	7/8"	3'-0"

EXISTING DEFORMATION TO BE STRAIGHTENED

(Looking South)
 (Approximate max. deflections)
 Deflected length of beam to be straightened is approximately "L".

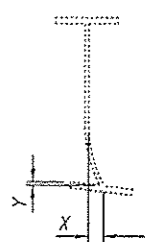

REP-1 J-14-2005

DESIGNED DAB	EXAMINED Timothy A. ...	DATE JUNE 26, 2012
CHECKED GGE	ACTING ENGINEER OF STRUCTURAL SERVICES	
DRAWN Kyle M. Steffen	PASSED Carl ...	REVISED
CHECKED DAB GGE	ACTING ENGINEER OF BRIDGES AND STRUCTURES	REVISED

STATE OF ILLINOIS
DEPARTMENT OF TRANSPORTATION

BEAM STRAIGHTENING DETAILS
SN 090-0091

SHEET NO. 2 OF 6 SHEETS

F.A.I. RTE.	SECTION	COUNTY	TOTAL SHEETS	SHEET NO.
74	(90-1448-18R)I-1	TAZEWELL	17	11
CONTRACT NO.				
ILLINOIS FED. AID PROJECT				

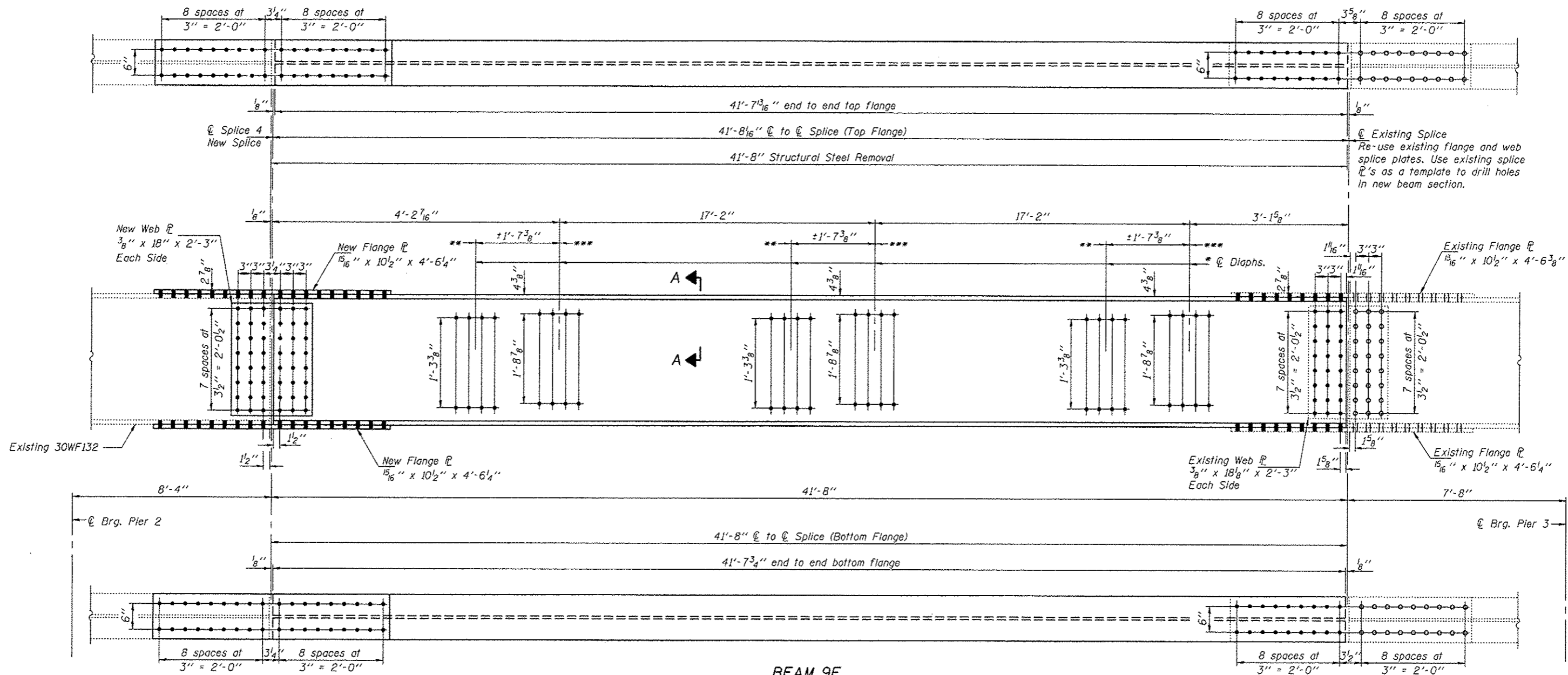

BEAM 9E

W30x132 x 41'-7 13/16" (1 Req'd) N.T.R.
 Web L 3/8" x 18" x 2'-3" (2 Req'd) N.T.R.
 Flange L 15/16" x 10 1/2" x 4'-6 1/4" (2 Req'd) N.T.R.

- * Holes for Diaphragms shall be field drilled.
- ** Diaphragm connecting to Beam 10.
- *** Diaphragm connecting to Beam 8E.

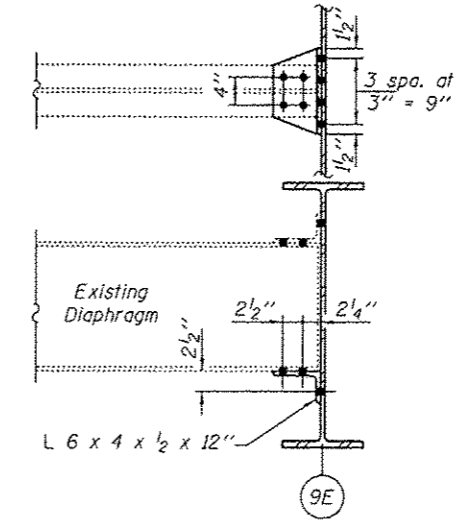
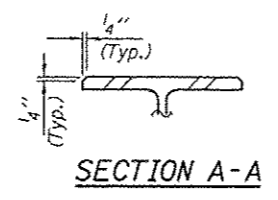

Notes:
 Removal of existing beam to be paid for as "Structural Steel Removal"
 New Beam, Splice L's, & Clip L's to be paid for as "Furnishing & Erecting Structural Steel."

DESIGNED DAB	EXAMINED <i>Timothy A. Dab</i>	DATE JUNE 26, 2012	STATE OF ILLINOIS DEPARTMENT OF TRANSPORTATION	BEAM 9E REPLACEMENT DETAILS		F.A.I. RTE. 74	SECTION 190-1410-110(9)1-1	COUNTY TAZEWELL	TOTAL SHEETS 17	SHEET NO. 12
CHECKED GGE	ACTING ENGINEER OF STRUCTURAL SERVICES			SN 090-0091				CONTRACT NO.		
DRAWN Kyle M. Steffen	ACTING ENGINEER OF BRIDGES AND STRUCTURES			SHEET NO. 3 OF 6 SHEETS				ILLINOIS FED. AID PROJECT		
CHECKED DAB GGE										

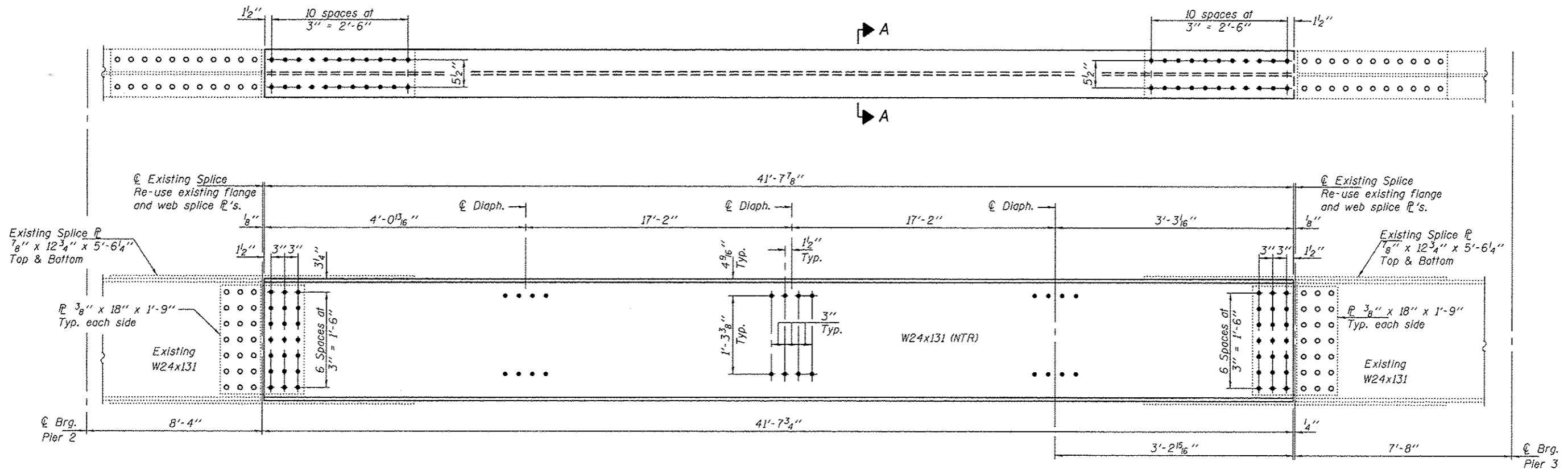

ELEVATION BEAM 12
(Looking West)

Notes:
 Field drill diaphragm holes in new beams using holes in existing clip L's as a template.
 Natural camber of new beam shall be placed upward for fabrication.
 Diaphragm connection holes shall be 1 5/16" for 3/4" bolts. Two hardened washers shall be required at diaphragm connections.
 Use existing splice L's as a template to field drill holes in new beam at existing splice locations.
 The cost of all field drilling required for installation of the steel members is included with Furnishing and Erecting Structural Steel.
 Removal of existing beam to be paid for as "Structural Steel Removal"
 New Beam, Splice L's, & Clip L's to be paid for as "Furnishing & Erecting Structural Steel."

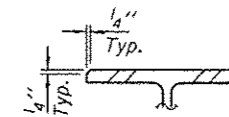

SECTION A-A

DESIGNED <i>DAB</i>	EXAMINED <i>Timothy A. Dab</i>	DATE <i>JUNE 26, 2012</i>	STATE OF ILLINOIS DEPARTMENT OF TRANSPORTATION		BEAM 12 REPLACEMENT DETAILS SN 090-0091		F.A.I. RTE.	SECTION	COUNTY	TOTAL SHEETS	SHEET NO.
CHECKED <i>GGE</i>	ACTING ENGINEER OF STRUCTURAL SERVICES	REVISOR					74	(90-14HB-1(BR))I-1	TAZENELL	17	13
DRAWN <i>Kyle M. Steffen</i>	ACTING ENGINEER OF BRIDGES AND STRUCTURES	REVISOR	SHEET NO. 4 OF 6 SHEETS		ILLINOIS FED. AID PROJECT		CONTRACT NO.				

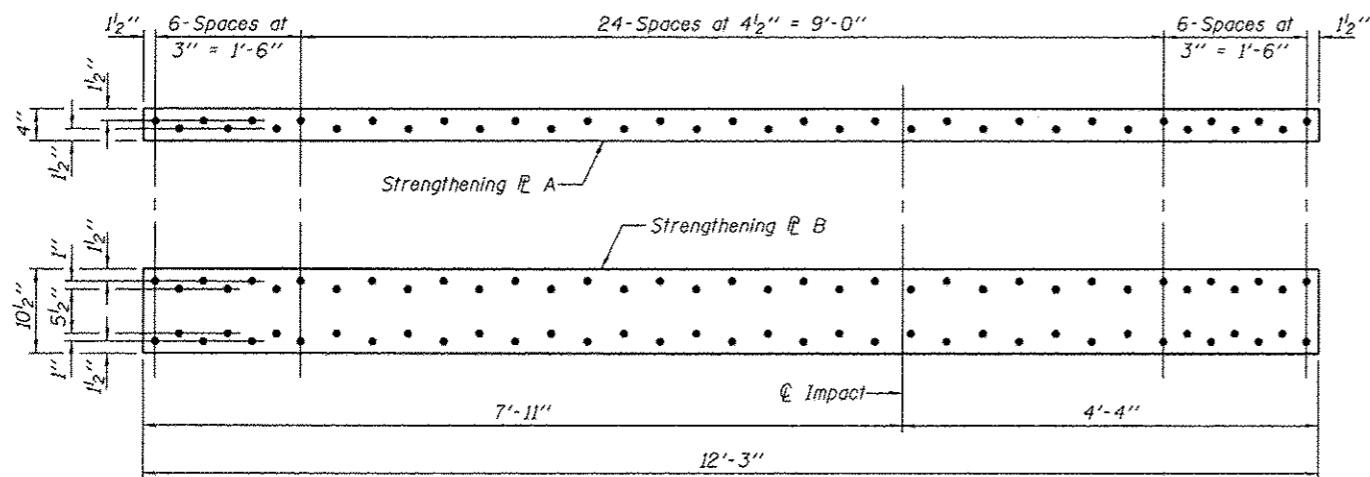

STRENGTHENING R'S A & B (BEAM 4E)
 (Holes to be field drilled using holes in beam flange as template.)
 R A $\frac{5}{8}$ " x 4" x 12'-3" (2 Required)
 R B $\frac{5}{8}$ " x 10 1/2" x 12'-3" (1 Required)

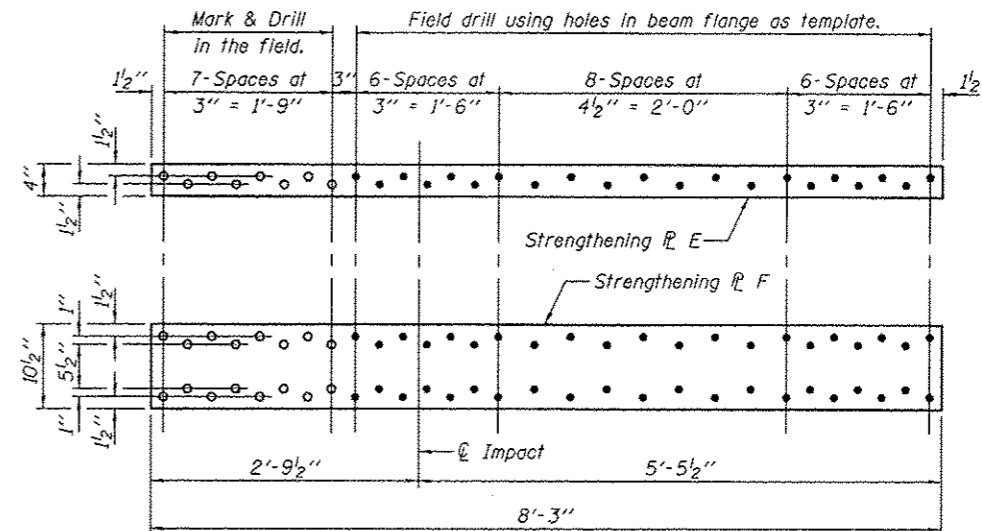

STRENGTHENING R'S E & F (BEAM 5E)
 R E $\frac{5}{8}$ " x 4" x 8'-3" (2 Required)
 R F $\frac{5}{8}$ " x 10 1/2" x 8'-3" (1 Required)

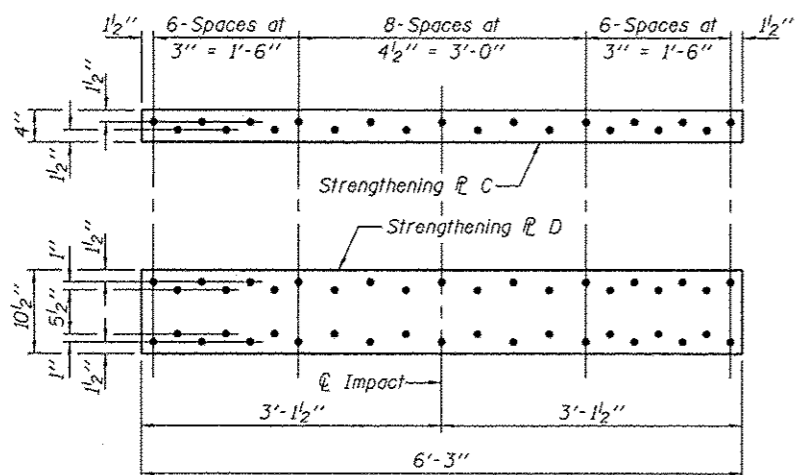

STRENGTHENING R'S C & D (BEAMS 6E, 7E & 8E)
 (Holes in beam flange to be field drilled using strengthening plates as template.)
 R C $\frac{5}{8}$ " x 4" x 6'-3" (6 Required)
 R D $\frac{5}{8}$ " x 10 1/2" x 6'-3" (3 Required)

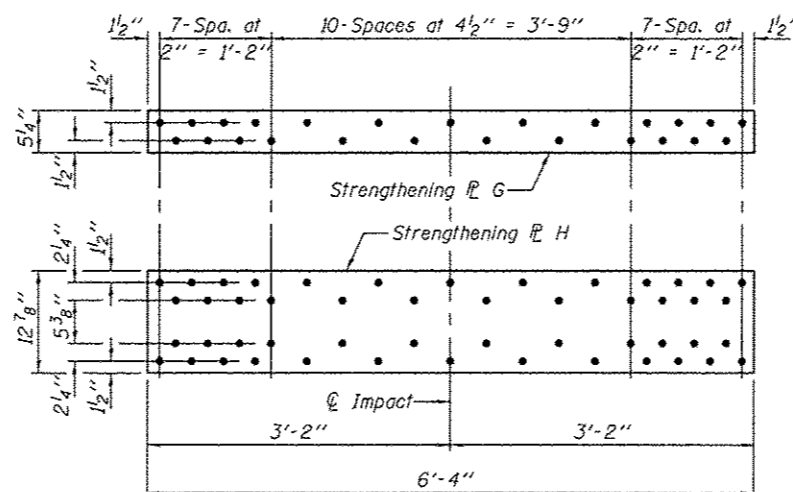

STRENGTHENING R'S G & H (BEAM 10)
 (Holes in beam flange to be field drilled using strengthening plates as template.)
 R G $\frac{9}{16}$ " x 5 1/4" x 6'-4" (2 Required)
 R H $\frac{9}{16}$ " x 12 7/8" x 6'-4" (1 Required)

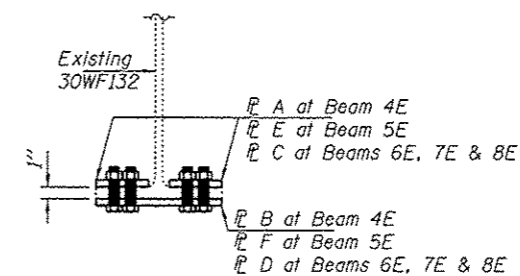

STRENGTHENING DETAIL FOR BEAMS 4E THRU 8E

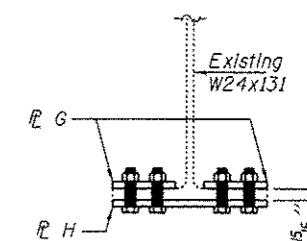

STRENGTHENING DETAIL FOR BEAM 10

Notes:
 Removal of existing Strengthening R's on Beams 4E & 5E to be paid for as "Structural Steel Removal".
 New Strengthening R's on Beams 4E thru 8E & 10 and field drilling of holes to be paid for as "Structural Steel Repair".

DESIGNED DAB	EXAMINED <i>Timothy A. D. [Signature]</i>	DATE JUNE 26, 2012	STATE OF ILLINOIS DEPARTMENT OF TRANSPORTATION		SLAB SUPPORT SYSTEM & STRENGTHENING PLATE DETAILS SN 090-0091	F.A.I. RTE. 74	SECTION 190-1408-10R03-1	COUNTY TAZEWELL	TOTAL SHEETS 17	SHEET NO. 14
CHECKED GGE	ACTING ENGINEER OF STRUCTURAL SERVICES		REVISOR			SHEET NO. 5 OF 6 SHEETS		CONTRACT NO. ILLINOIS FED. AID PROJECT		
DRAWN Kyle M. Steffen	ACTING ENGINEER OF BRIDGES AND STRUCTURES		REVISOR							
CHECKED DAB GGE										

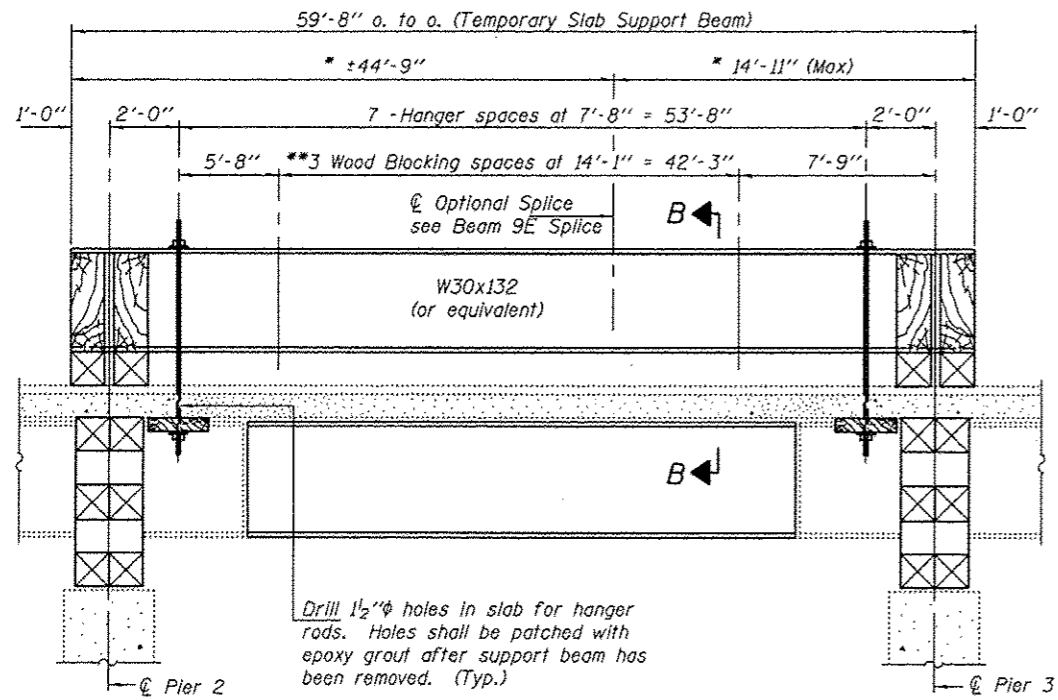

**LONGITUDINAL SECTION AT BEAM 9E
SUGGESTED TEMPORARY SLAB SUPPORT SYSTEM**

* These dimensions may vary for available beams in stock.

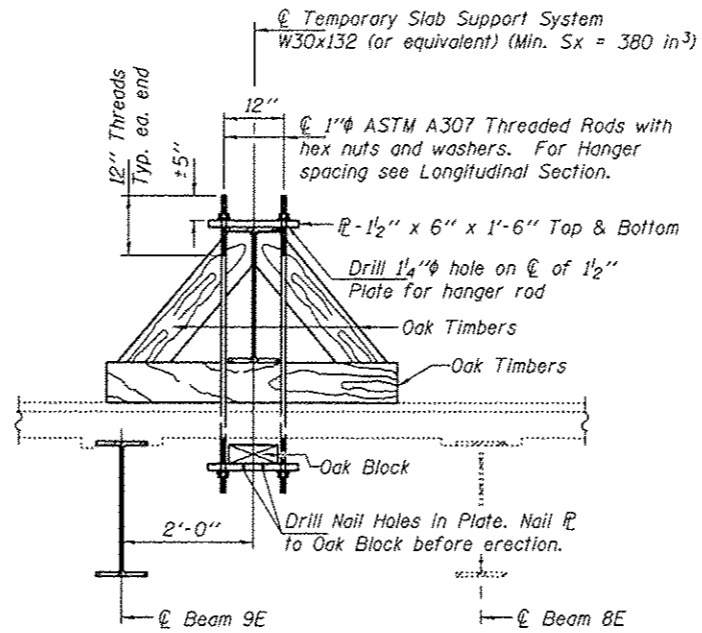

SECTION B-B

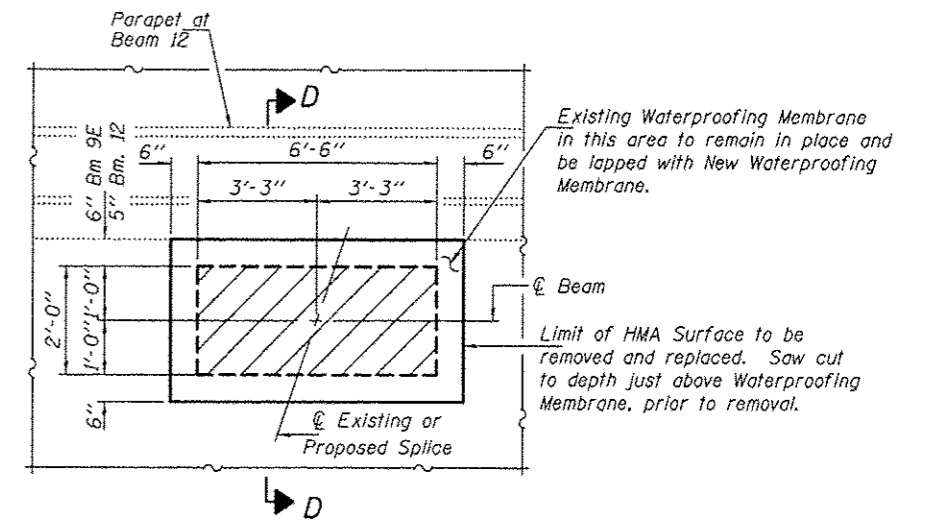

**TYPICAL CONCRETE & HMA
SURFACE REMOVAL AND REPLACEMENT**

Notes
 Hatched areas indicate concrete sections to be removed and replaced. Perimeters of concrete removal areas shall be saw cut 3/4" prior to the removal of concrete.
 Reinforcement shall be cut only if required for fitting bolts. Cut reinforcement shall be spliced as directed by the Engineer. Cost shall be included with Concrete Removal.
 The cost of removing and replacing the existing HMA wearing surface, waterproofing membrane, and saw cutting shall be included with Concrete Removal.

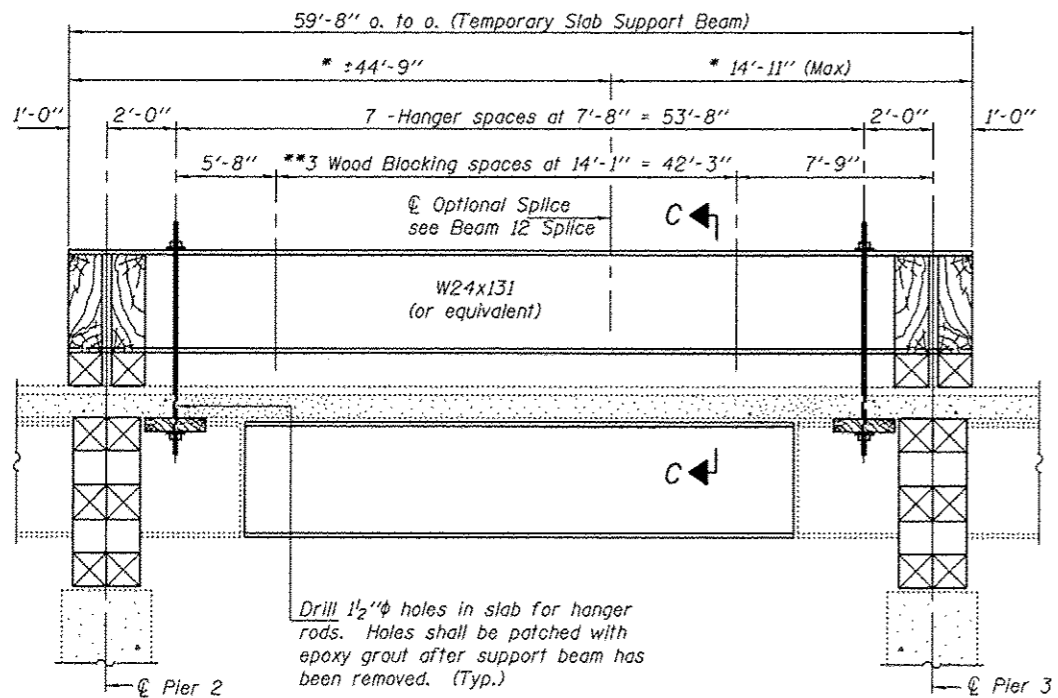

**LONGITUDINAL SECTION AT BEAM 12
SUGGESTED TEMPORARY SLAB SUPPORT SYSTEM**

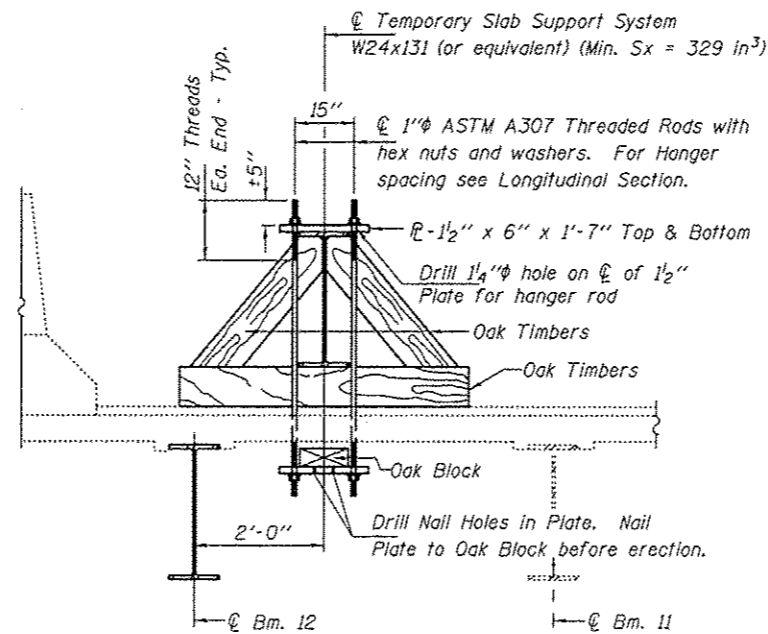

SECTION C-C

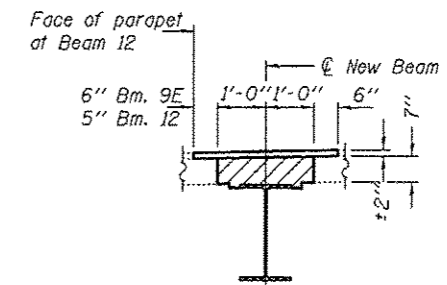

SECTION D-D

DESIGNED	DAB
CHECKED	GGE
DRAWN	Kyle M. Steffen
CHECKED	DAB GGE

EXAMINED	<i>Timothy A. ...</i>
PASSED	<i>...</i>

DATE	JUNE 26, 2012
REVISED	
REVISED	

**STATE OF ILLINOIS
DEPARTMENT OF TRANSPORTATION**

TEMPORARY SLAB SUPPORT SYSTEM DETAILS
 SN 090-0091
 SHEET NO. 6 OF 6 SHEETS

F.A.I. RTE.	SECTION	COUNTY	TOTAL SHEETS	SHEET NO.
74	(90-1440-118R)1-1	TAZEWELL	17	15
CONTRACT NO.				
ILLINOIS FED. AID PROJECT				

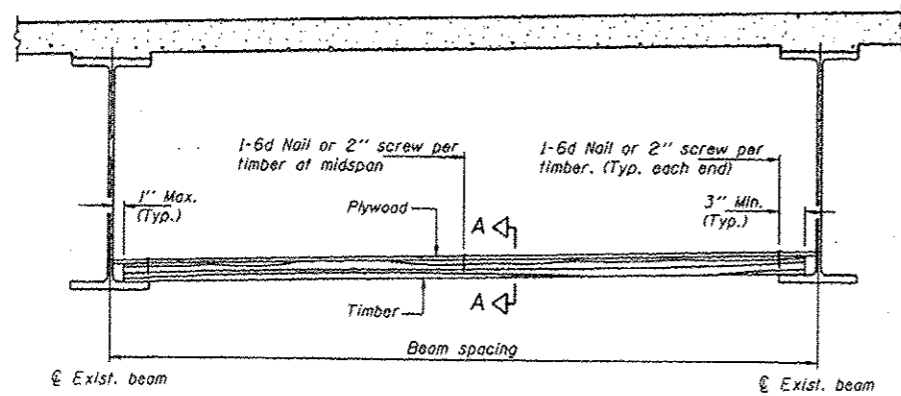

STEEL BEAMS

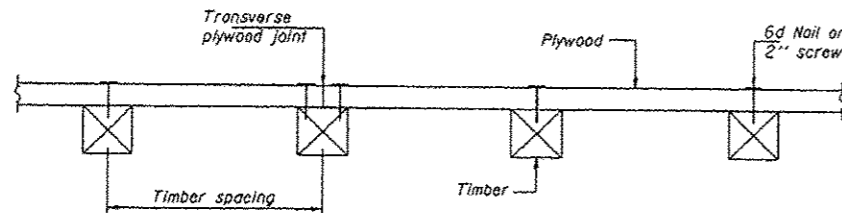

SECTION A-A

TIMBER SPACING

Beam Spacing (ft.)	Timber Sizes (in.)		
	4" x 4" with min. Fb=775 psi Fv=135 psi	4" x 6" with min. Fb=775 psi Fv=135 psi	6" x 6" with min. Fb=575 psi Fv=125 psi
	Maximum Timber Spacing (in.)		
4.5	16	16	16
4.75	16	16	16
5.0	16	16	16
5.25	16	16	16
5.5	16	16	16
5.75	16	16	16
6.0	16	16	16
6.25	12	16	16
6.5	12	16	16
6.75	12	16	16
7.0	8	16	16
7.25	8	16	16
7.5	8	16	16
7.75	8	16	16
8.0	8	12	16
8.25	8	12	16
8.5	6	12	12
8.75	6	12	12
9.0	6	8	12

Notes:
 Timber sizes shown are nominal sizes. Rough sown timber of the dimensions shown will also be considered acceptable.
 The minimum Fb and Fv values shown are the tabulated design values given in the National Design Specification for Wood Construction for No. 2 Spruce-Pine-Fir without adjustment factors applied. Better grades or other species with equal or higher allowable stresses will also be considered acceptable.
 The timber spacings shown have been determined using allowable stresses with all adjustment factors necessary for the anticipated service conditions.
 All timber shall be treated.
 Plywood shall be 5/8" Exterior type plywood.
 Plywood shall be placed such that the face grain is perpendicular to the timber supports. When less than a full sheet (4' width) of plywood is used, the width of the strip used shall not be less than 2'.
 Transverse plywood joints shall be supported by timbers.
 When 4" x 6" timbers are used, they shall be placed such that the wide face is horizontal and the narrow face is vertical.
 Design load = 200 psf.

BILL OF MATERIAL

Item	Unit	Total
Protective Shield (Permanent)	Sq. Yd.	195

(Quantity shown is original Protective Shielding Installation)

S:\GEN-DRAFT-ST04PLNS-SquadBRIDGES-BRIDGE CONTRACTS-STEEL BEAM REP-88819 SN090-0091-PinecrestDR-over-174.dgn

PPS-1	05-03-07	DESIGNED - CEJ	REVISED -	STATE OF ILLINOIS DEPARTMENT OF TRANSPORTATION	PERMANENT PROTECTIVE SHIELD PINECREST DRIVE OVER F.A.I. ROUTE 74 SN 090-0091	F.A.I. RTE.	SECTION	COUNTY	TOTAL SHEETS	SHEET NO.	
FILE NAME *	USER NAME * jonesco	DESIGNED - CEJ	REVISED -			74	(90-14NB-1(BR)II	TAZEWELL	7	16	
S:\GEN-DRAFT-ST04PLNS-SquadBRIDGES-BRIDGE CONTRACTS-STEEL BEAM REP-88819 SN090-0091-PinecrestDR-over-174.dgn	05-03-07	CHECKED - ---	REVISED -			STEEL BEAMS REP./REPL.	CONTRACT NO. 68819				
PLOT SCALE * 1/2" = 1'-0"	DATE - 06/15/2012	CHECKED - ---	REVISED -			FED. ROAD DIST. NO. 4 ILLINOIS FED. AID PROJECT					

DETAIL OF INERTIAL BARRIERS
(55 MPH (90 km/h) DESIGN - 40' (12.2m) MEDIAN)

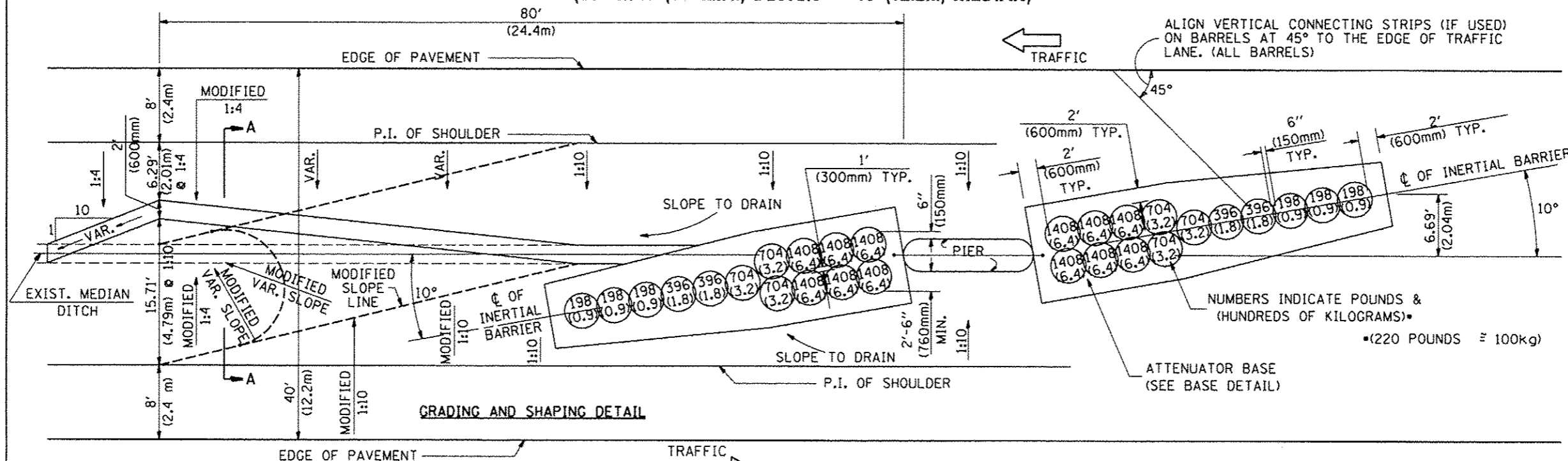

GENERAL NOTES

1. ALL 1:10 SLOPES SHOWN ON THIS DETAIL SHALL BE CONSTRUCTED 1:10 OR FLATTER.
2. ANY EXISTING DRAINAGE STRUCTURES LOCATED WITHIN THE 80' (24.4m) WORKING AREA SHALL BE MODIFIED OR LEFT IN PLACE AS SHOWN ON THE PLANS. WHERE THE EXISTING DRAINAGE STRUCTURES ARE TO REMAIN IN PLACE, THE SLOPES ARE TO BE CONSTRUCTED AS SHOWN AS MODIFIED SLOPES ON THIS DETAIL AND AS DIRECTED BY THE ENGINEER.
3. THE SLOPES AS SHOWN ON THIS DETAIL SHALL APPLY TO BOTH ENDS OF THE BRIDGE PIERS.
4. THE LENGTH X WIDTH OF MODULE LAYOUT IS 34.5' x 6.5' (10.52m x 1.98m)
14 MODULES - MASS 11,900 LBS. (5430kg)
5. IN AREAS OF 1:10 SLOPES PRECEDING THE ATTENUATOR IN THE MEDIAN INSTALLATION, FOUR WOOD POSTS SHALL BE PLACED AT 5' (1.5m) INTERVALS IN THE MEDIAN C, SEE SPECIAL PROVISIONS.

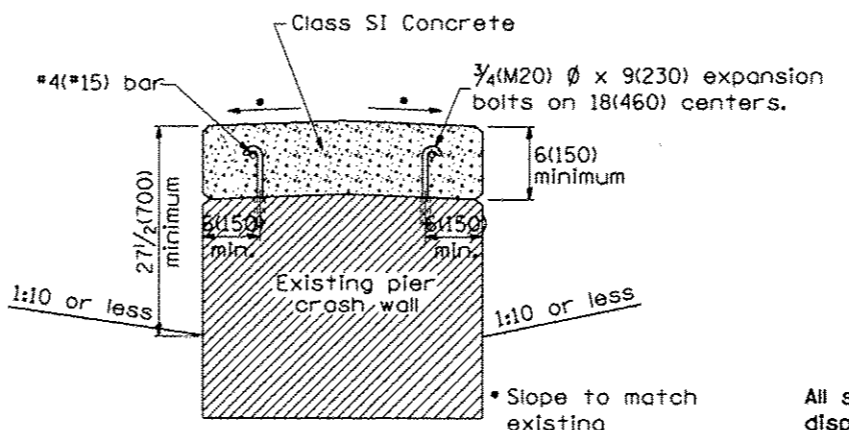
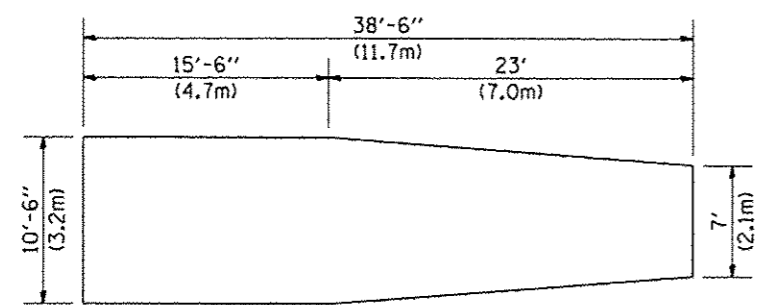
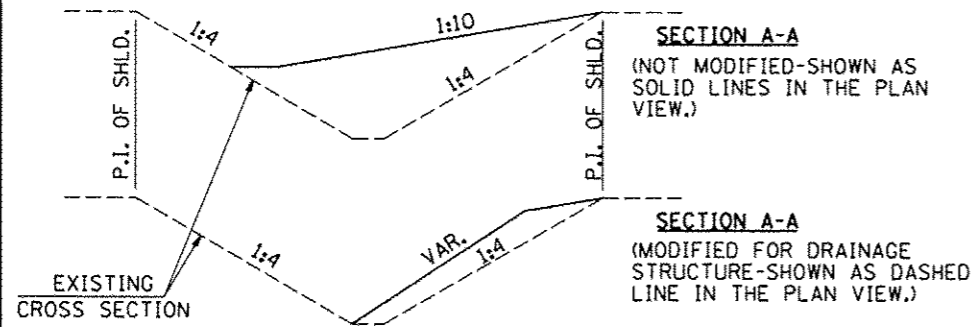

TYPICAL PIER CRASH WALL RECONSTRUCTION
(Optional: Reconstruction required in order to meet 27 1/2 (700) minimum height.)

All slope ratios are expressed as units of vertical displacement to units of horizontal displacement (V:H)

All dimensions are in inches (millimeters) unless otherwise noted.