

STATE OF ILLINOIS
DEPARTMENT OF TRANSPORTATION

F.A.D. DIST.	SECTION	COUNTY	TOWN	SHEET
1487 18-00113-00-RS		DUPAGE		19
FED. ROAD DIST NO 1		ILLINOIS	FED. AID PROJECT	
CONTRACT NO. 61E92				

PLANS FOR PROPOSED
FEDERAL AID HIGHWAY
FAU ROUTE 1487 (MAPLE AVENUE)
FAU 2615 (MAIN STREET) TO FAU 2637 (FAIRVIEW AVENUE)
RESURFACING
SECTION: 18-00113-00-RS
PROJECT: AA7X(839)
VILLAGE OF DOWNERS GROVE
DUPAGE COUNTY
C-91-148-18

FOR INDEX OF SHEETS, SEE SHEET NO. 2

FOR LIST OF HIGHWAY STANDARDS, SEE SHEET NO. 2

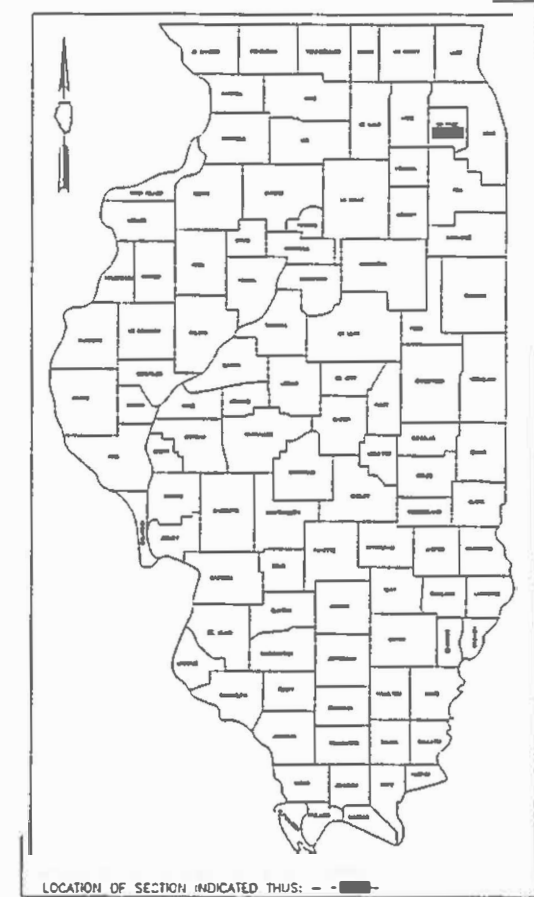

MAPLE AVENUE DESIGN DESIGNATION
MAJOR COLLECTOR
SPEED LIMIT: 30 MPH
2016 ADT 6,350

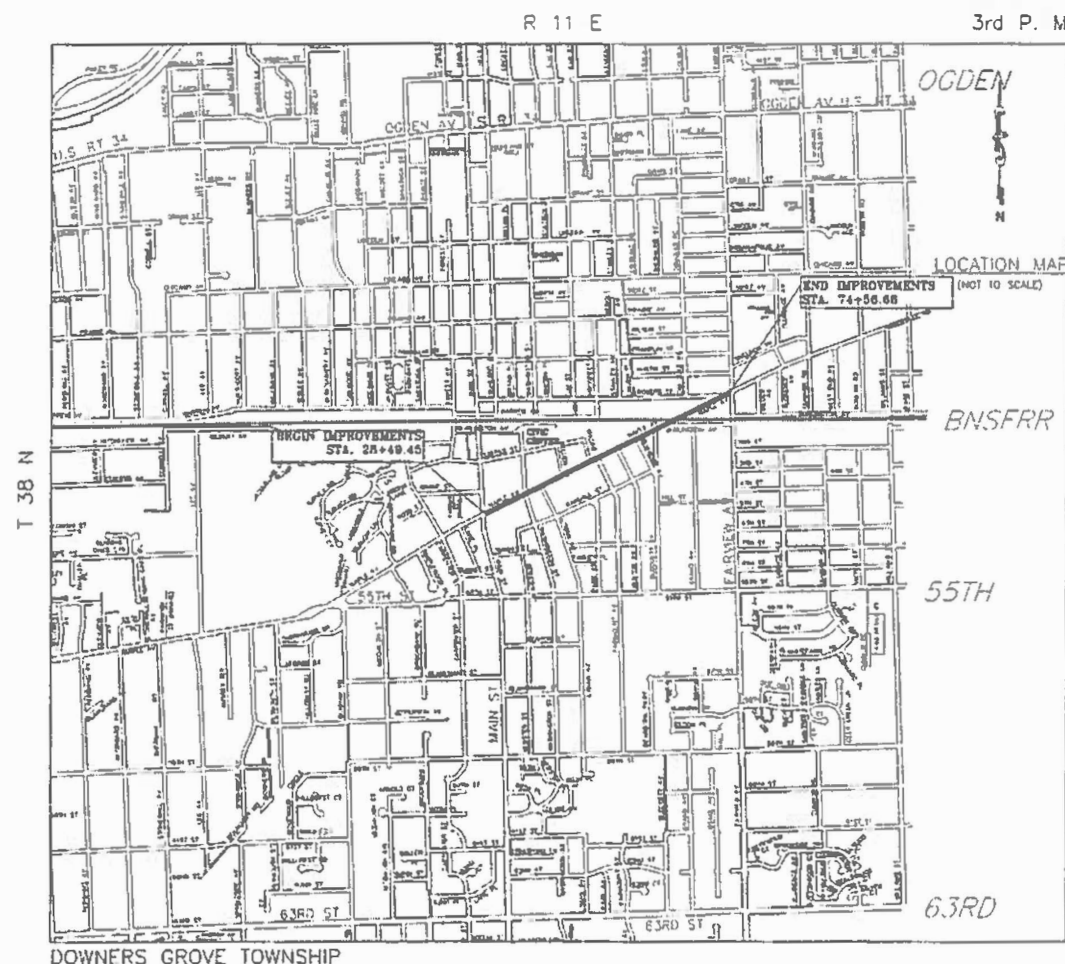

OMISSION FROM
STA 61+75 TO
STA 65+87 (BNSFRR)

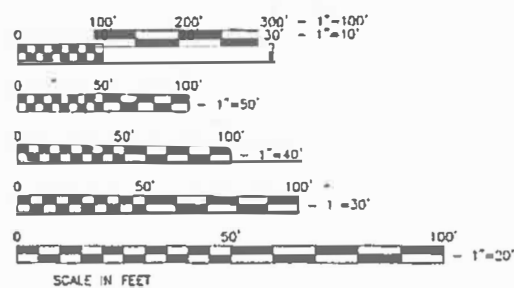

GROSS LENGTH: 4,599.85 FT = 0.87 MILE
NET LENGTH: 4,187.85 FT = 0.79 MILE

STATE OF ILLINOIS
DEPARTMENT OF TRANSPORTATION

APPROVED April 23 2018
Nareil Newlon
DIRECTOR OF PUBLIC WORKS, VILLAGE OF DOWNERS GROVE

PASSED MAY 22 2018
Chris Holt CHRISTOPHER HOLT
DIVISION ENGINEER OF LOCAL ROADS AND STREETS

RELEASING FOR BID
BASED ON LIMITED
REVIEW may 22 2018
Anthony J. Rayley
REGIONAL ENGINEER



James P. Tuck, P.E.
#062 002783
My License Expires 11/30/19

PRINTED BY THE AUTHORITY
OF THE STATE OF ILLINOIS

CHARLES F. RIDDLER, P. E. SCHAUMBURG, IL

PROGRAM AND OFFICE ENGINEER:

FULL SIZE PLANS HAVE BEEN PREPARED USING STANDARD ENGINEERING
SCALES. REDUCED SIZE PLANS WILL NOT CONFORM TO STANDARD SCALES.
IN MAKING MEASUREMENTS ON REDUCED PLANS, THE ABOVE SCALES CAN BE USED

INDEX OF SHEETS

<u>SHEET NO.</u>	<u>DESCRIPTION</u>
1	COVER SHEET & LOCATION MAP
2	GENERAL NOTES & INDEX OF STANDARDS
3	SUMMARY OF QUANTITIES
4	EXISTING TYPICAL SECTIONS
5	PROPOSED TYPICAL SECTIONS
6	PLAN SHEET (STA 28+00 TO STA 40+00)
7	PLAN SHEET (STA 40+00 TO STA 52+00)
8	PLAN SHEET (STA 52+00 TO STA 64+00)
9	PLAN SHEET (STA 64+00 TO STA 74+78)
10	SIDEWALK DETAILS
11	SIDEWALK DETAILS
12	VILLAGE DETAILS
13	BD-08 DETAILS FOR FRAMES AND LIDS ADJUSTMENT WITH MILLING
14	BD-22 PAVEMENT PATCHING FOR HMA SURFACED PAVEMENT
15	BD-32 BUTT JOINT AND HMA TAPER DETAILS
16	TC-10 TRAFFIC CONTROL AND PROTECTION FOR SIDE ROADS, INTERSECTIONS AND DRIVEWAYS
17	TC-13 DISTRICT ONE TYPICAL PAVEMENT MARKINGS DETAIL
18	TC-16 PAVEMENT MARKING LETTERS & SYMBOLS FOR TRAFFIC STAGING
19	TC-22 ARTERIAL ROAD INFORMATION SIGN

GENERAL NOTES

- ALL REFERENCES TO THE 'VILLAGE' IN THESE GENERAL NOTES SHALL BE INTERPRETED TO MEAN THE VILLAGE OF DOWNERS GROVE.
- ALL REFERENCES TO THE 'STANDARD SPECIFICATIONS' IN THESE GENERAL NOTES SHALL BE INTERPRETED TO MEAN THE 'STANDARD SPECIFICATIONS FOR ROAD AND BRIDGE CONSTRUCTION' ADOPTED BY THE ILLINOIS DEPARTMENT OF TRANSPORTATION (IDOT) ON APRIL 1, 2016, ALONG WITH SUPPLEMENTAL SPECIFICATIONS AND RECURRING SPECIAL PROVISIONS AS ADOPTED JANUARY 1, 2018.
- THE LOCATIONS OF PUBLIC OR PRIVATE UTILITIES SHOWN ON THE PLANS ARE APPROXIMATE AND THE VILLAGE, DEPARTMENT, AND THE ENGINEERS DO NOT GUARANTEE THEIR ACCURACY. THE CONTRACTOR WILL BE REQUIRED TO ASCERTAIN THE EXACT LOCATION OF SUCH UTILITIES AND EXERCISE CARE DURING THE CONSTRUCTION OPERATION SO AS NOT TO DAMAGE THEM. IN ACCORDANCE WITH THE SPECIAL PROVISIONS AND ARTICLE 107.20 OF THE 'STANDARD SPECIFICATIONS' THE CONTRACTOR SHALL BE RESPONSIBLE FOR CONTACTING THE OWNERS OF ALL EXISTING UTILITIES SO THAT THEIR FACILITIES MAY BE LOCATED AND ADJUSTED OR MOVED, IF NECESSARY, PRIOR TO THE START OF CONSTRUCTION OPERATIONS.
- THOSE EXISTING TRAFFIC SIGNS WHICH ARE SO DESIGNATED BY THE ENGINEER SHALL BE REMOVED, STORED AND SUBSEQUENTLY RELOCATED BY THE CONTRACTOR IN ACCORDANCE WITH ARTICLE 107.25. ANY SIGNS WHICH ARE DAMAGED BY THE CONTRACTOR AS DETERMINED BY THE ENGINEER SHALL BE REPLACED IN KIND BY THE CONTRACTOR AND TO THE SATISFACTION OF THE ENGINEER.
- ALL TRAFFIC CONTROL AND OTHER ADVISORY SIGNS NEEDED FOR CONSTRUCTION ARE TO BE FURNISHED BY THE CONTRACTOR IN ACCORDANCE WITH THE PLANS AND IDOT STANDARDS FOR TRAFFIC CONTROL AND PROTECTION.
- SAW CUTTING OF PAVEMENTS, SIDEWALK, ETC. SHALL BE FULL DEPTH AND SHALL RESULT IN A CLEAN STRAIGHT EDGE ON THE PORTION REMAINING.
- SPECIAL ATTENTION IS CALLED TO ARTICLE 107.15 OF THE STANDARD SPECIFICATIONS. WHERE THE CONTRACTOR'S EQUIPMENT IS OPERATED ON ANY PORTION OF THE PAVEMENT OR STRUCTURES USED BY TRAFFIC ON OR ADJACENT TO THE SECTION UNDER CONSTRUCTION, THE CONTRACTOR SHALL CLEAN THE PAVEMENT OF ALL DIRT AND DEBRIS AT THE END OF EACH DAY'S OPERATIONS, AND AT OTHER TIMES AS DIRECTED BY THE ENGINEER.
- THE CONTRACTOR SHALL BE RESPONSIBLE FOR THE PROTECTION OF ALL UNDERGROUND OR SURFACE UTILITIES EVEN THOUGH THEY MAY NOT BE SHOWN ON THE PLANS. ANY UTILITY THAT IS DAMAGED DURING CONSTRUCTION SHALL BE REPAIRED OR REPLACED TO THE SATISFACTION OF THE ENGINEER.
- WHENEVER, DURING CONSTRUCTION OPERATIONS, ANY LOOSE MATERIAL IS DEPOSITED IN THE FLOW LINE OF DRAINAGE STRUCTURES SUCH THAT THE NATURAL FLOW OF WATER IS OBSTRUCTED, IT SHALL BE REMOVED AT THE CLOSE OF EACH WORKING DAY. AT THE CONCLUSION OF CONSTRUCTION OPERATIONS, ALL DRAINAGE STRUCTURES SHALL BE FREE OF DIRT AND DEBRIS.
- THE CONTRACTOR SHALL NOT OPEN OR SHUT ANY WATER VALVES OR FIRE HYDRANTS WITHOUT PRIOR AUTHORIZATION FROM THE VILLAGE WATER DEPARTMENT.
- QUANTITIES FOR PATCHING SHALL NOT EXCEED THOSE PROVIDED IN THE SUMMARY OF QUANTITIES UNLESS APPROVED BY THE ENGINEER. THE ENGINEER WILL VERIFY FINAL PATCH LOCATIONS IN THE FIELD PRIOR TO REMOVAL.
- HOT-MIX ASPHALT SURFACE REMOVAL BUTT JOINTS WILL BE INSTALLED AT THE ENDS OF ALL RESURFACING (WHERE RESURFACING MEETS EXISTING PAVEMENT), IN ACCORDANCE WITH THE BUTT JOINT AND HOT-MIX ASPHALT TAPER DETAILS SHEET INCLUDED IN THE PLANS, UNLESS OTHERWISE SPECIFIED.
- THE THICKNESS OF THE HOT-MIX ASPHALT MIXTURES SHOWN IN THE PLANS ARE NORMAL. DEVIATIONS MAY OCCUR DUE TO IRREGULARITIES IN THE SURFACES OR BASE ON WHICH THEY ARE PLACED. PLAN THICKNESS SHOULD BE CONSIDERED THE MINIMUM THICKNESS PERMITTED.

14. MAILBOXES WHICH ARE IN CONFLICT WITH PROPOSED IMPROVEMENTS SHALL BE REMOVED, TEMPORARILY RELOCATED, AND REPLACED UPON COMPLETION OF THE PROPOSED IMPROVEMENTS IN ACCORDANCE WITH ARTICLE 107.20 AND AS DIRECTED BY THE ENGINEER.

15. THE CONTRACTOR SHALL NOT PLACE SOD UNTIL THE TEMPERATURE IS 80 DEGREES OR LESS AND THE FORECAST FOR THE NEXT 7 DAYS SHOWS TEMPERATURES OF 80 DEGREES OR LESS. IF ALL OTHER PAY ITEMS ARE COMPLETED THE CONTRACTOR WILL NOT BE CHARGED WORKING DAYS FOR DELAYS IN PARKWAY RESTORATION DUE TO TEMPERATURE.

16. SPECIAL ATTENTION IS CALLED TO ARTICLE 107.30 OF THE STANDARD SPECIFICATIONS. THE CONTRACTOR SHALL BE RESPONSIBLE TO THWART DEFACEMENT OF ANY CONCRETE POURS BEFORE THEY HAVE SET UP. CONCRETE SIDEWALK, DRIVEWAY, CURB, AND CURB AND GUTTER THAT HAVE BEEN DEFACTED, IN THE OPINION OF THE ENGINEER, SHALL BE REMOVED AND REPLACED BY THE CONTRACTOR.

17. FOR WORK OUTSIDE LIMITS OF BRIDGE APPROACH PAVEMENT, ALL REFERENCES IN THE HIGHWAY STANDARDS AND STANDARD SPECIFICATIONS FOR REINFORCEMENT, DOWEL BARS AND TIE BARS IN PAVEMENT, SHOULDERS, CURB, GUTTER, COMBINATION CURB AND GUTTER AND MEDIAN, AND CHAIR SUPPORTS FOR CRC PAVEMENT, SHALL BE EPOXY COATED, UNLESS NOTED ON THE PLAN.

18. RESTORATION WORK WILL BE PAID FOR UP TO 2 FEET ADJACENT TO RECONSTRUCTED CURB AND GUTTER OR SIDEWALK. AREAS OUTSIDE THE 2 FEET ZONE THAT ARE DAMAGED OR DISTURBED BY THE CONTRACTOR SHALL BE RESTORED BY THE CONTRACTOR AT HIS OWN EXPENSE.

19. CONTRACTOR SHALL BE CAUTIOUS NOT TO DISTURB ANY PARKWAY TREES DURING CONSTRUCTION. ANY TREES THAT ARE DAMAGED OR DISTURBED DURING CONSTRUCTION SHALL BE REPLACED IN KIND BY THE CONTRACTOR AT HIS OWN EXPENSE. NO ADDITIONAL COMPENSATION WILL BE ALLOWED.

IDOT STANDARDS

000001-06	STANDARD SYMBOLS, ABBREVIATIONS, AND PATTERNS
280001-07	TEMPORARY EROSION CONTROL SYSTEMS
424001-10	PERPENDICULAR CURB RAMPS FOR SIDEWALKS
424011-03	CORNER PARALLEL CURB RAMPS FOR SIDEWALKS
424016-04	MID-BLOCK CURB RAMPS FOR SIDEWALKS
442201-03	CLASS C & D PATCHES
606001-07	CONCRETE CURB TYPE B & COMBINATION CONCRETE CURB AND GUTTER
701006-05	OFF-RD OPERATIONS, 2L, 2W, 15' TO 24" FROM PAVEMENT EDGE
701301-04	LANE CLOSURE, 2L, 2W SHORT TIME OPERATIONS
701311-03	LANE CLOSURE, 2L, 2W MOVING OPERATIONS - DAY ONLY
701501-06	URBAN LANE CLOSURE, 2L, 2W, UNDIVIDED
701502-08	URBAN LANE CLOSURE, 2L, 2W WITH BIDIRECTIONAL LEFT TURN LANE
701701-10	URBAN LANE CLOSURE, MULTILANE INTERSECTION
701801-06	SIDEWALK, CORNER OR CROSSWALK CLOSURE
701901-07	TRAFFIC CONTROL DEVICES
780001-05	TYPICAL PAVEMENT MARKINGS

FILE NAME =	USER NAME -- USER	DESIGNED -- NRH	REVISED
FILE NAME =		DRAWN -- NRH	REVISED
	PLOT SCALE --	CHECKED -- JPT	REVISED
	PLOT DATE -- 04/19/18	DATE -- 04/19/18	REVISED

STATE OF ILLINOIS
DEPARTMENT OF TRANSPORTATION

MAPLE AVENUE IMPROVEMENTS
GENERAL NOTES AND INDEX OF STANDARDS

NOT TO SCALE SHEET NO. 1 OF 1 SHEETS STA. TO STA.

F.A.U. RTE.	SECTION	COUNTY	TOTAL SHEETS	SHEET NO.
1487	18-00113-00-RS	DUPAGE	19	2
			CONTRACT NO. 61E92	
FED. ROAD DIST. NO. 1		ILLINOIS	FED. AID PROJECT	

SUMMARY OF QUANTITIES

MAPLE AVENUE				
CODE NO.	ITEM	UNIT	TOTAL QUANTITY	CONSTRUCTION TYPE CODE 0005
20200100	EARTH EXCAVATION	CY YD	20	20
21101615	TOPSOIL FURNISH AND PLACE, 4"	SQ YD	300	300
25200110	SODDING, SALT TOLERANT	SQ YD	300	300
25200200	SUPPLEMENTAL WATERING	UNIT	5	5
28000510	INLET FILTERS	EACH	33	33
35101600	AGGREGATE BASE COURSE, TYPE B 4"	SQ YD	170	170
40600290	BITUMINOUS MATERIALS (TACK COAT)	POUND	9,850	9,850
40600400	MIXTURE FOR CRACKS, JOINTS, AND FLANGEWAYS	TON	10	10
40600827	POLYMERIZED LEVELING BINDER (MACHINE METHOD), IL-4.75, N50	TON	645	645
40600982	HOT-MIX ASPHALT SURFACE REMOVAL - BUTT JOINT	SQ YD	275	275
40603335	HOT-MIX ASPHALT SURFACE COURSE, MIX "D", N50	TON	1,285	1,285
42300200	PORTLAND CEMENT CONCRETE DRIVEWAY PAVEMENT 6 INCH	SQ YD	100	100
42400200	PORTLAND CEMENT CONCRETE SIDEWALK 5 INCH	SQ FT	3,000	3,000
42400800	DETECTABLE WARNINGS	SQ FT	310	310
44000157	HOT-MIX ASPHALT SURFACE REMOVAL, 2"	SQ YD	14,560	14,560
44000200	DRIVEWAY PAVEMENT REMOVAL	SQ YD	200	200
44000500	COMBINATION CURB AND GUTTER REMOVAL	FOOT	500	500
44000600	SIDEWALK REMOVAL	SQ FT	3,000	3,000
44201690	CLASS D PATCHES, TYPE I, 4 INCH	SQ YD	45	45
44201692	CLASS D PATCHES, TYPE II, 4 INCH	SQ YD	55	55
44201694	CLASS D PATCHES, TYPE III, 4 INCH	SQ YD	160	160
44201696	CLASS D PATCHES, TYPE IV, 4 INCH	SQ YD	105	105
44201713	CLASS D PATCHES, TYPE I, 6 INCH	SQ YD	30	30
44201717	CLASS D PATCHES, TYPE II, 6 INCH	SQ YD	50	50
44201721	CLASS D PATCHES, TYPE III, 6 INCH	SQ YD	160	160
44201723	CLASS D PATCHES, TYPE IV, 6 INCH	SQ YD	105	105

MAPLE AVENUE				
CODE NO.	ITEM	UNIT	TOTAL QUANTITY	CONSTRUCTION TYPE CODE 0005
60266600	VALVE BOXES TO BE ADJUSTED	EACH	8	8
60300305	FRAMES AND LIDS TO BE ADJUSTED	EACH	12	12
60406000	FRAMES AND LIDS, TYPE 1, OPEN LID	EACH	1	1
60406100	FRAMES AND LIDS, TYPE 1, CLOSED LID	EACH	1	1
60603800	COMBINATION CONCRETE CURB AND GUTTER, TYPE B-6.12	FOOT	500	500
67100100	MOBILIZATION	L SUM	1	1
70102620	TRAFFIC CONTROL AND PROTECTION, STANDARD 701501	L SUM	1	1
70102622	TRAFFIC CONTROL AND PROTECTION, STANDARD 701502	L SUM	1	1
70102635	TRAFFIC CONTROL AND PROTECTION, STANDARD 701701	L SUM	1	1
70102640	TRAFFIC CONTROL AND PROTECTION, STANDARD 701801	L SUM	1	1
70300100	SHORT TERM PAVEMENT MARKING	FOOT	11,600	11,600
70300150	SHORT TERM PAVEMENT MARKING REMOVAL	SQ FT	3,900	3,900
* 78000100	THERMOPLASTIC PAVEMENT MARKING - LETTERS AND SYMBOLS	SQ FT	255	255
* 78000200	THERMOPLASTIC PAVEMENT MARKING - LINE 4"	FOOT	7,900	7,900
* 78000400	THERMOPLASTIC PAVEMENT MARKING - LINE 6"	FOOT	1,700	1,700
* 78000600	THERMOPLASTIC PAVEMENT MARKING - LINE 12"	FOOT	260	260
* 78000650	THERMOPLASTIC PAVEMENT MARKING - LINE 24"	FOOT	300	300
X0320050	CONSTRUCTION LAYOUT (SPECIAL)	L SUM	1	1
X6030310	FRAMES AND LIDS TO BE ADJUSTED (SPECIAL)	EACH	19	19
X6061005	CONCRETE CURB TYPE B (SPECIAL)	FOOT	95	95
Z0004510	HMA DRIVEWAY PAVEMENT, 3"	SQ YD	100	100
Z0030850	TEMPORARY INFORMATION SIGNING	SQ FT	52	52

* DENOTES SPECIALTY ITEM

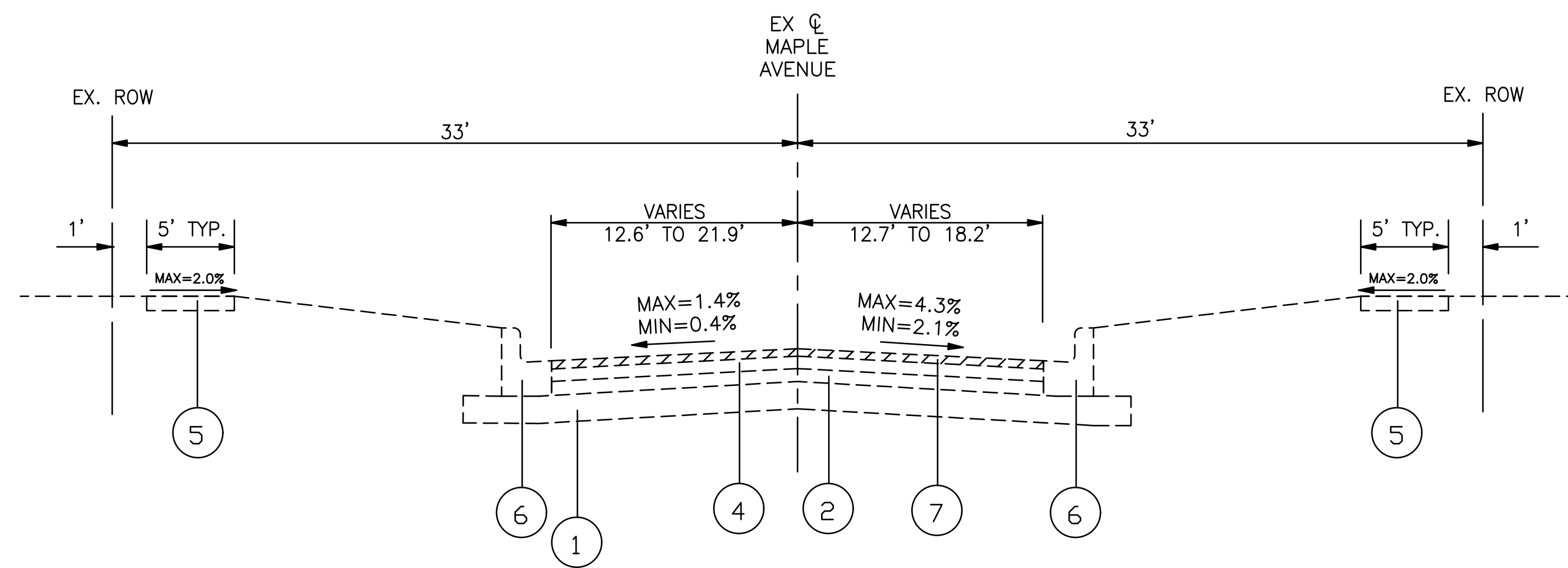

EXISTING TYPICAL SECTION

STA. 28+49 TO STA. 34+99, MAPLE AVENUE
 STA. 34+99 TO STA. 36+35, MAPLE AVENUE TAPER SECTION

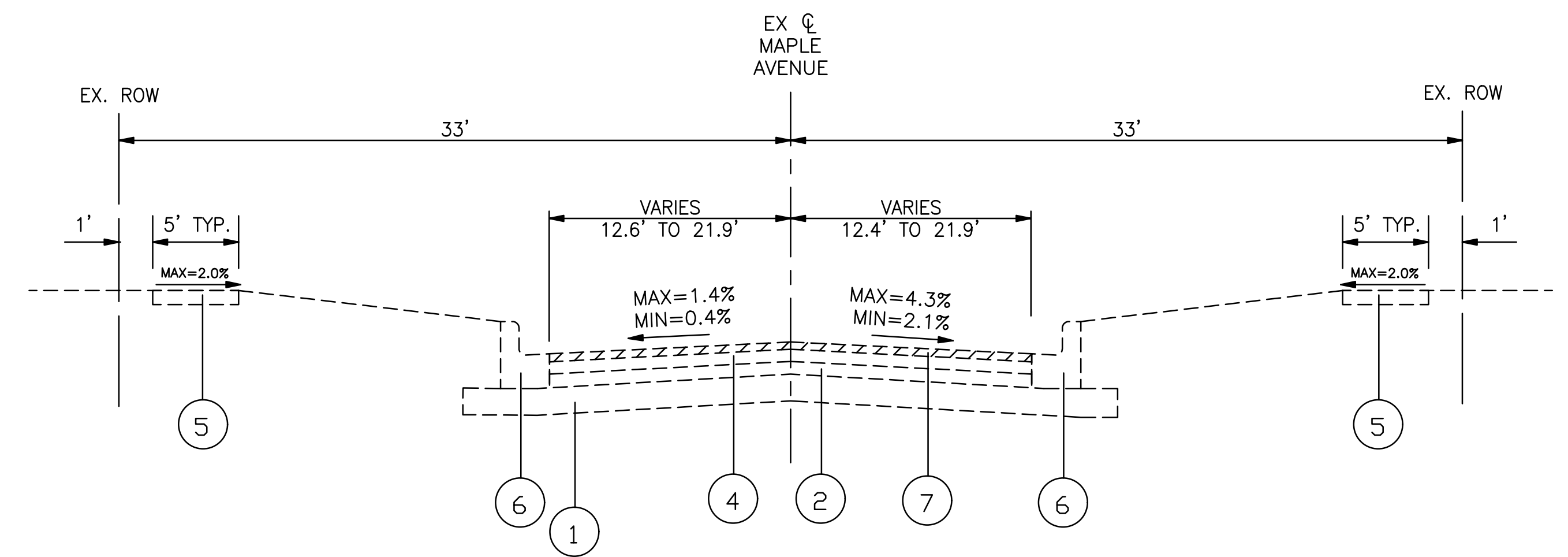

EXISTING TYPICAL SECTION

STA. 36+35 TO STA. 39+00, MAPLE AVENUE TAPER SECTION
 STA. 39+00 TO STA. 61+75, MAPLE AVENUE

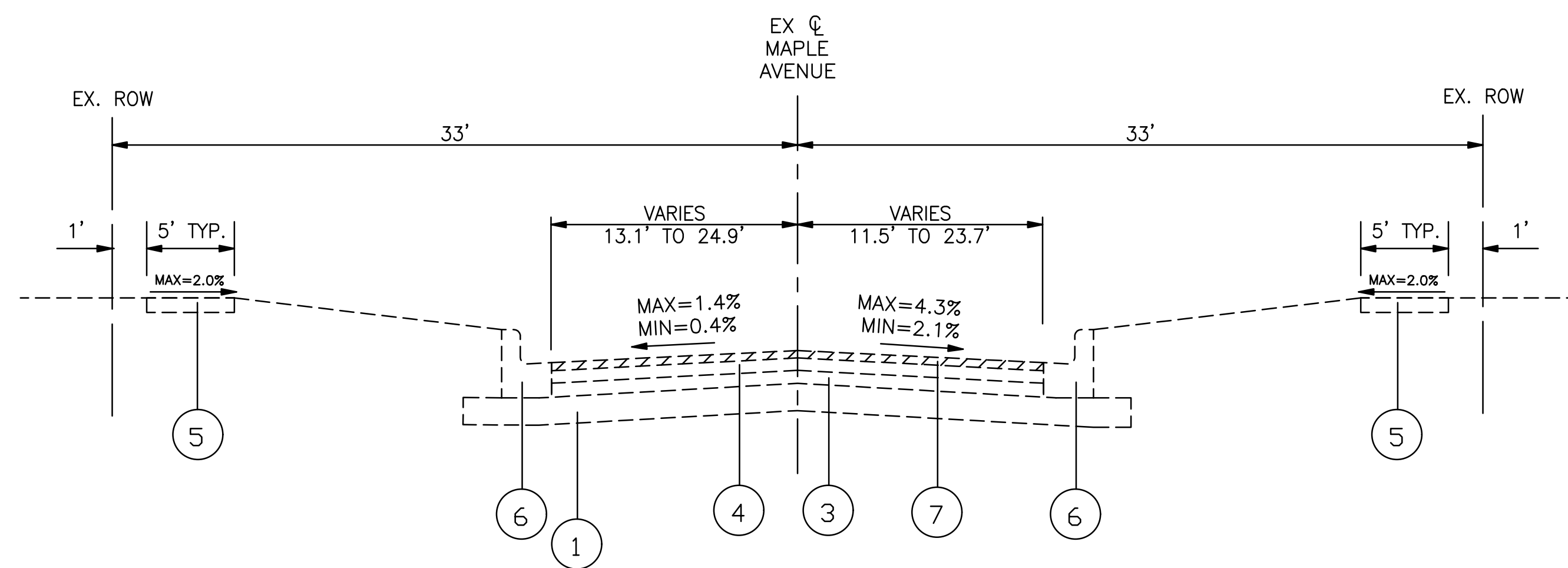

EXISTING TYPICAL SECTION

STA. 65+87 TO STA. 71+20, MAPLE AVENUE
 STA. 71+20 TO STA. 71+69, MAPLE AVENUE TAPER SECTION
 STA. 71+69 TO STA. 74+57, MAPLE AVENUE

HATCH LEGEND

REMOVAL ITEMS
 (WHERE SHOWN ON PLANS)

NOTE OF NO IMPROVEMENTS INCLUDED IN THIS CONTRACT:
 OMISSION STA. 61+75 TO STA. 65+87, MAPLE AVENUE

LEGEND

- ① EXISTING SUBGRADE
- ② EXISTING BRICK BASE COURSE, 4"
- ③ EXISTING PORTLAND CEMENT BASE COURSE, 3-1/2" - 5-1/2", VARIES
- ④ EXISTING BITUMINOUS PAVEMENT, 2" - 8", VARIES
- ⑤ EXISTING PORTLAND CEMENT CONCRETE SIDEWALK, REMOVAL WHERE SHOWN ON PLANS AND AS DETERMINED IN THE FIELD BY ENGINEER
- ⑥ EXISTING COMBINATION CONCRETE CURB & GUTTER, TYPE B6.12, REMOVAL WHERE SHOWN ON PLANS AND AS DETERMINED IN THE FIELD BY ENGINEER
- ⑦ PROPOSED HMA SURFACE REMOVAL, 2"

FILE NAME =	USER NAME -- USER	DESIGNED -- NRH	REVISED
FILE NAME =		DRAWN -- NRH	REVISED
	PLOT SCALE --	CHECKED -- JPT	REVISED
	PLOT DATE -- 04/19/18	DATE -- 04/19/18	REVISED

STATE OF ILLINOIS
 DEPARTMENT OF TRANSPORTATION

MAPLE AVENUE IMPROVEMENTS
 EXISTING TYPICAL SECTIONS

NOT TO SCALE SHEET NO. 1 OF 1 SHEETS STA. TO STA.

F.A.U. RTE.	SECTION	COUNTY	TOTAL SHEETS	SHEET NO.
1487	18-00113-00-RS	DUPAGE	19	4
CONTRACT NO. 61E92				
FED. ROAD DIST. NO. 1	ILLINOIS	FED. AID PROJECT		

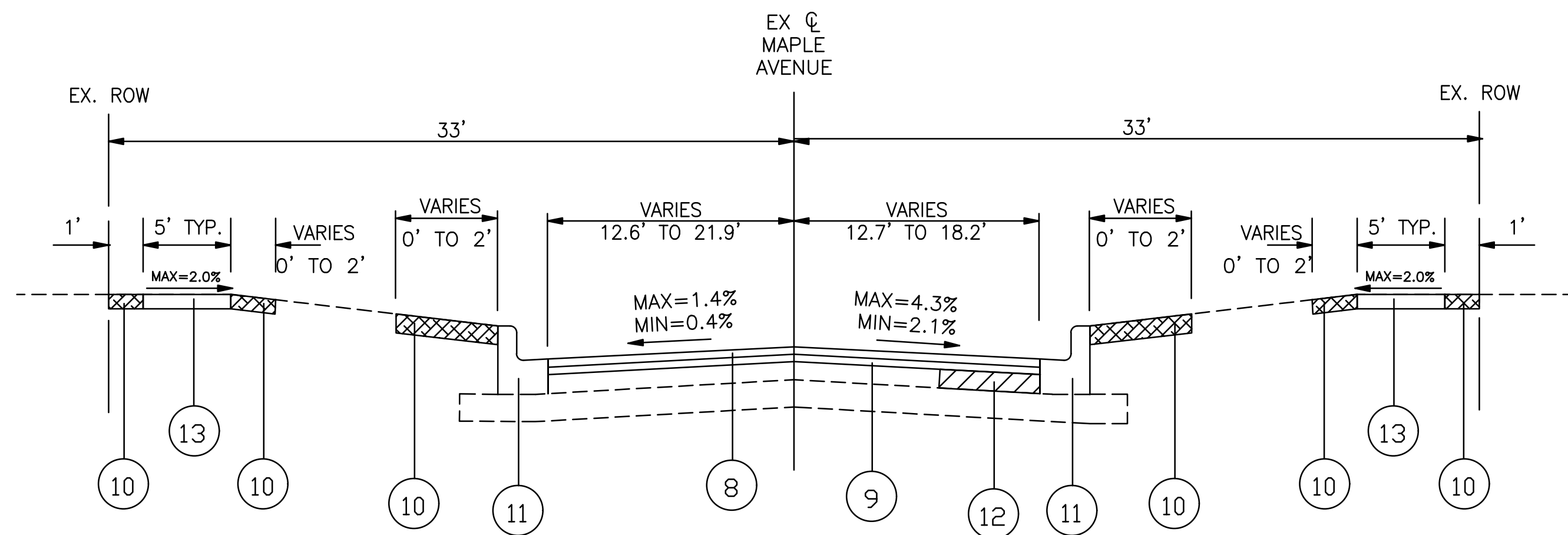

NOTE: ALL WORK IS WITHIN EXISTING ROW

PROPOSED TYPICAL SECTION

STA. 28+49 TO STA. 34+99, MAPLE AVENUE

STA. 34+99 TO STA. 36+35, MAPLE AVENUE TAPER SECTION

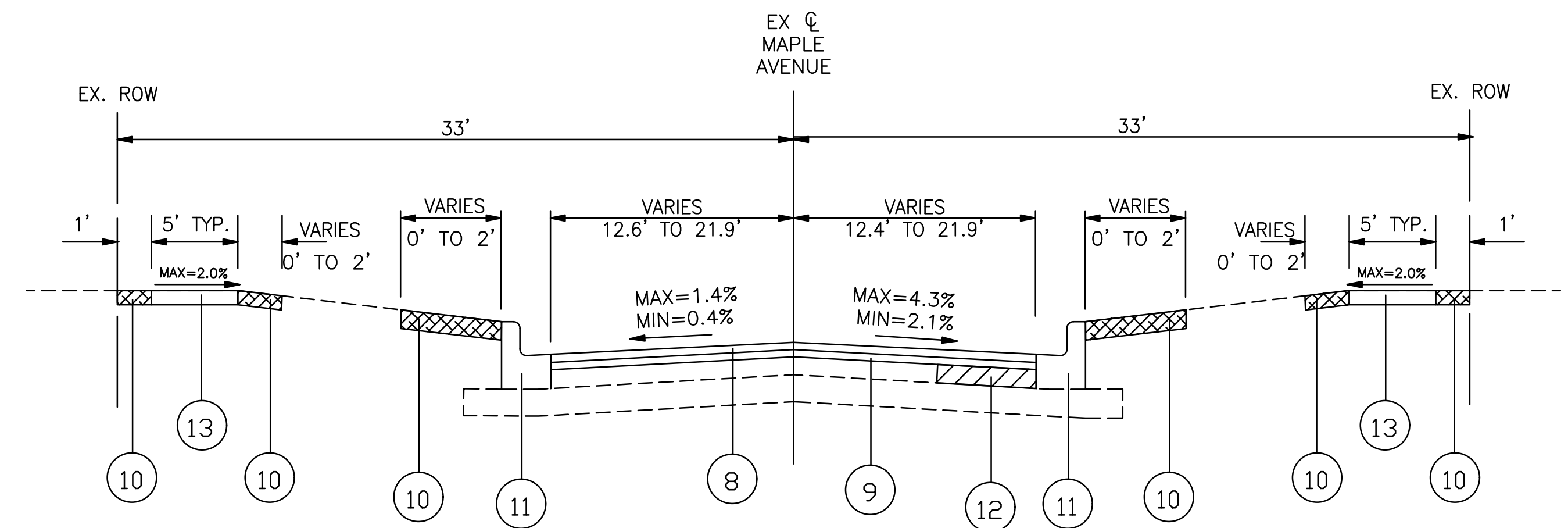

NOTE: ALL WORK IS WITHIN EXISTING ROW

PROPOSED TYPICAL SECTION

STA. 36+35 TO STA. 39+00, MAPLE AVENUE TAPER SECTION

STA. 39+00 TO STA. 61+75, MAPLE AVENUE

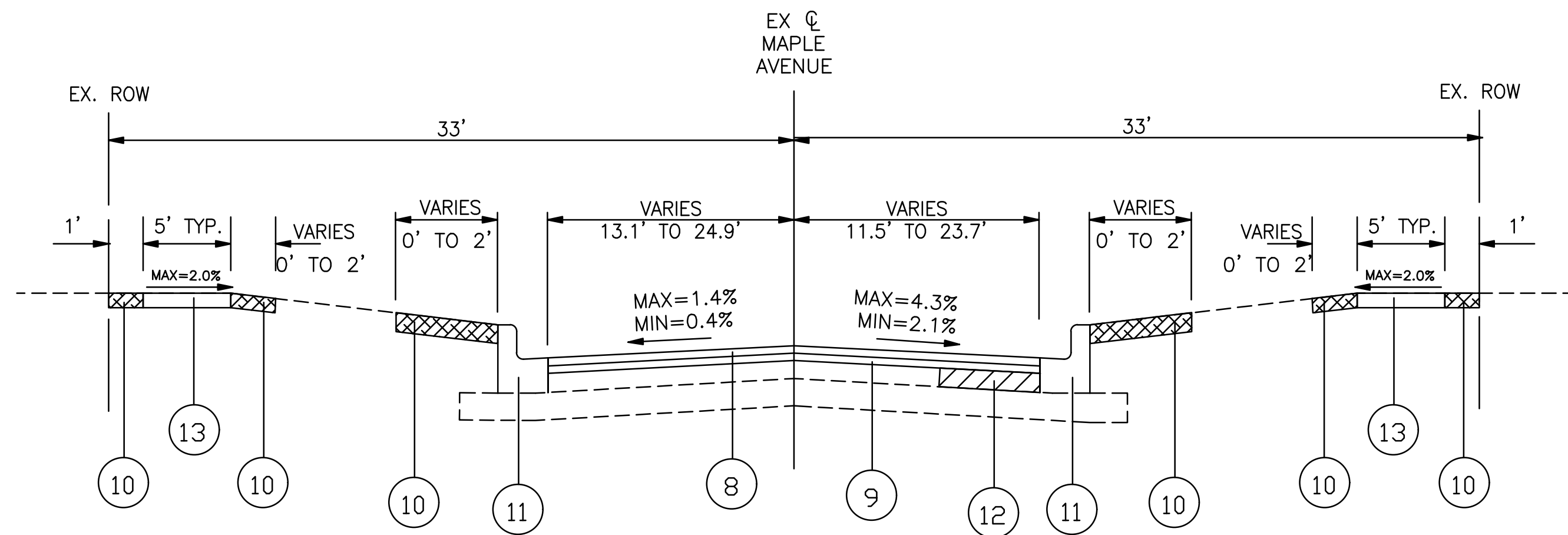

NOTE: ALL WORK IS WITHIN EXISTING ROW

PROPOSED TYPICAL SECTION

STA. 65+87 TO STA. 71+20, MAPLE AVENUE

STA. 71+20 TO STA. 71+69, MAPLE AVENUE TAPER SECTION

STA. 71+69 TO STA. 74+57, MAPLE AVENUE

NOTE OF NO IMPROVEMENTS INCLUDED IN THIS CONTRACT:
OMISSION STA. 61+75 TO STA. 65+87, MAPLE AVENUE

CONTRACTOR SHALL MILL FIRST BEFORE PATCHING

HOT-MIX ASPHALT MIXTURE REQUIREMENTS	
MIXTURE TYPE	AIR VOIDS @ Ndes
ROADWAYS:	
HOT-MIX ASPHALT SURFACE COURSE, MIX "D", N50 (IL 9.5 mm), 1 1/2"	4% @ 50 GYR
POLYMERIZED LEVELING BINDER (MACHINE METHOD), IL-4.75, N50, 3/4"	3.5% @ 50 GYR
DRIVEWAYS:	
HOT-MIX ASPHALT SURFACE COURSE, MIX "D" N50 - 3"	4% @ 50 GYR
PATCHING:	
CLASS D PATCHES, (HMA BINDER) IL-19mm, N70, 4" (IN 2 LIFTS)	4% @ 70 GYR
CLASS D PATCHES, (HMA BINDER) IL-19mm, N70, 6" (IN 2 LIFTS)	4% @ 70 GYR

-THE LONGITUDINAL JOINT SEALANT SHALL BE PLACED UNDER THE SURFACE LIFT.

-THE UNIT WEIGHT USED TO CALCULATE ALL HMA SURFACE MIXTURE QUANTITIES IS 112 LBS/SQYD/IN.

-THE "AC TYPE" FOR POLYMERIZED HMA MIXES SHALL BE "SBS/SBR PG 76 - 22" AND FOR NON-POLYMERIZED HMA THE "AC TYPE" SHALL BE "PG 64 - 22" UNLESS MODIFIED BY DISTRICT ONE SPECIAL PROVISIONS. FOR USE OF "RECYCLED MATERIAL" SEE DISTRICT ONE SPECIAL PROVISIONS.

LEGEND

- ⑧ PROPOSED HMA SURFACE COURSE, MIX "D", N50, 1 1/2"
- ⑨ PROPOSED POLYMERIZED LEVELING BINDER (MACHINE METHOD), IL-4.75, N50, 3/4"
- ⑩ PROPOSED SODDING, SALT TOLERANT & TOP SOIL FURNISH AND PLACE, 4" (LOCATIONS DETERMINED BY ENGINEER)
- ⑪ PROPOSED COMBINATION CONCRETE CURB & GUTTER, TYPE B6.12 REPLACEMENT, WHERE SHOWN ON PLANS AND AS DETERMINED IN THE FIELD BY ENGINEER
- ⑫ CLASS D PATCH (LOCATION AND DIMENSIONS DETERMINED BY ENGINEER), 4" OR 6"
- ⑬ PROPOSED PORTLAND CEMENT CONCRETE SIDEWALK, WHERE SHOWN ON PLAN AND AS DETERMINED IN THE FIELD BY ENGINEER

HATCH LEGEND

REMOVAL ITEMS

FILE NAME =	USER NAME -- USER	DESIGNED -- NRH	REVISED
FILE NAME =		DRAWN -- NRH	REVISED
	PLOT SCALE --	CHECKED -- JPT	REVISED
	PLOT DATE -- 04/19/18	DATE -- 04/19/18	REVISED

STATE OF ILLINOIS
DEPARTMENT OF TRANSPORTATION

MAPLE AVENUE IMPROVEMENTS
PROPOSED TYPICAL SECTIONS

NOT TO SCALE	SHEET NO. 1 OF 1 SHEETS	STA. TO STA.	F.A.U. SECTION COUNTY TOTAL SHEETS SHEET NO. 1487 18-00113-00-RS DUPAGE 19 5
			CONTRACT NO. 61E92
			FED. ROAD DIST. NO. 1 ILLINOIS FED. AID PROJECT

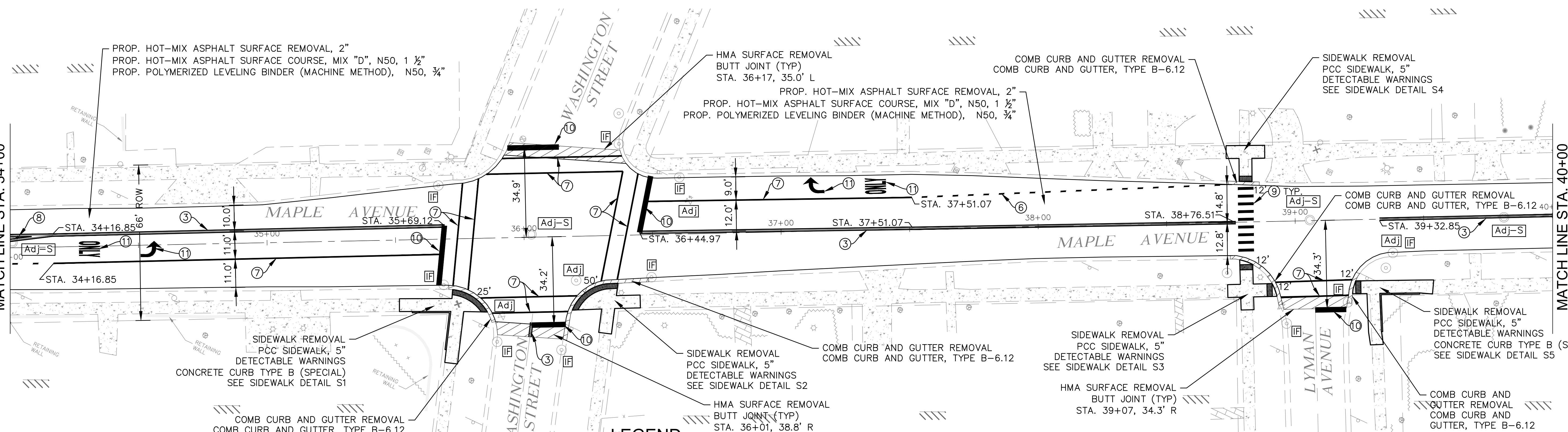
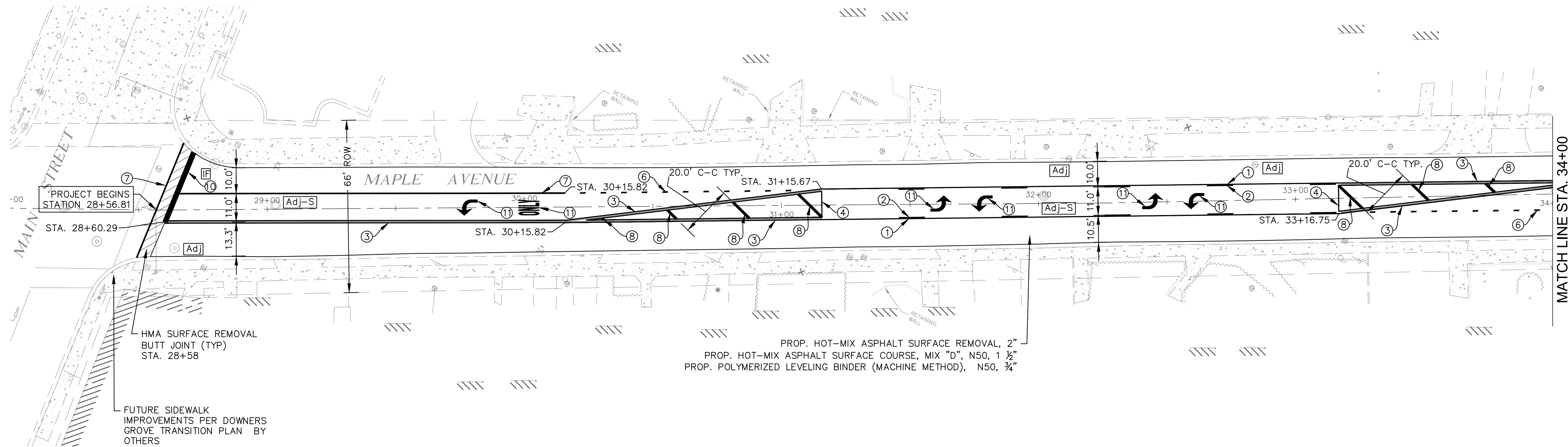
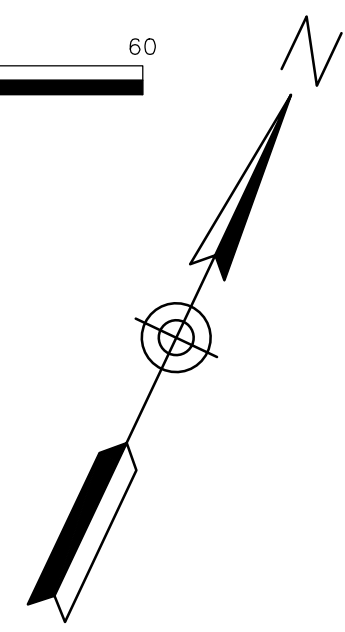
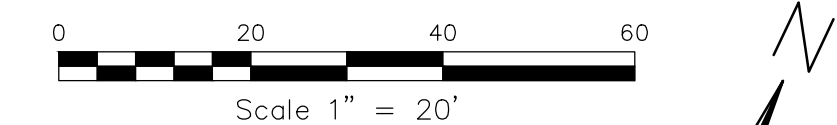

- NOTES**
1. CLASS D PATCHES, 4" OR 6" AS DIRECTED BY THE ENGINEER.
 2. ALL EXISTING DRAINAGE STRUCTURES WHICH ARE TO BE ADJUSTED SHALL BE CLEANED IN ACCORDANCE WITH ARTICLE 602.15 OF THE STANDARD SPECIFICATIONS. THE COST OF THIS WORK SHALL BE INCLUDED IN THE COST OF THE ADJUSTMENT ITEM.
 3. TOPSOIL, SODDING LOCATION/PLACEMENT AS DIRECTED BY THE ENGINEER.
 4. ALL CURB AND GUTTER TO MATCH EXISTING EDGE OF PAVEMENT UNLESS OTHERWISE NOTED.
 5. SIDEWALK REPLACEMENT NOT SHOWN ON PLANS TO BE COMPLETED BY OTHERS.

- LEGEND**
- [Adj] DRAINAGE & UTILITY STRUCTURES TO BE ADJUSTED
 - [Adj-S] SANITARY STRUCTURE TO BE ADJUSTED SEE DETAIL ON SHEET 12
 - [IF] INLET FILTERS
 - [Hatched] REMOVE AND REPLACE EXISTING CURB AND GUTTER
 - [Cross-hatched] REMOVE EXISTING SIDEWALK

- PAVEMENT MARKING LEGEND** | NOTE: REPLACEMENT IN KIND (TYP.)
- ① 4" YELLOW THERMOPLASTIC LINE @ 5 1/2" C-C - SOLID
 - ② 4" YELLOW THERMOPLASTIC LINE @ 5 1/2" C-C - SKIP DASH
 - ③ 4" DOUBLE YELLOW THERMOPLASTIC LINE @ 11" C-C - SOLID
 - ④ 4" YELLOW THERMOPLASTIC LINE - SOLID
 - ⑤ 4" WHITE THERMOPLASTIC LINE - SOLID
 - ⑥ 6" WHITE THERMOPLASTIC LINE - 2' DASH 6' SKIP
 - ⑦ 6" WHITE THERMOPLASTIC LINE - SOLID
 - ⑧ 12" YELLOW THERMOPLASTIC LINE - SOLID
 - ⑨ 12" WHITE THERMOPLASTIC LINE - SOLID
 - ⑩ 24" WHITE THERMOPLASTIC LINE - SOLID
 - ⑪ LETTERS AND SYMBOLS - FULL SIZE

FILE NAME =	USER NAME - USER	DESIGNED - NRH	REVISED
FILE NAME =		DRAWN - NRH	REVISED
	PLOT SCALE -	CHECKED - JPT	REVISED
	PLOT DATE - 04/19/18	DATE - 04/19/18	REVISED

STATE OF ILLINOIS
DEPARTMENT OF TRANSPORTATION

MAPLE AVENUE IMPROVEMENTS
IMPROVEMENT PLAN

SCALE: 1"=20' | SHEET NO. 1 OF 4 SHEETS | STA. 28+00 TO STA. 40+00

F.A.U. RTE.	SECTION	COUNTY	TOTAL SHEETS	SHEET NO.
1487	18-00113-00-RS	DUPAGE	19	6
CONTRACT NO. 61E92				
FED. ROAD DIST. NO. 1		ILLINOIS	FED. AID PROJECT	

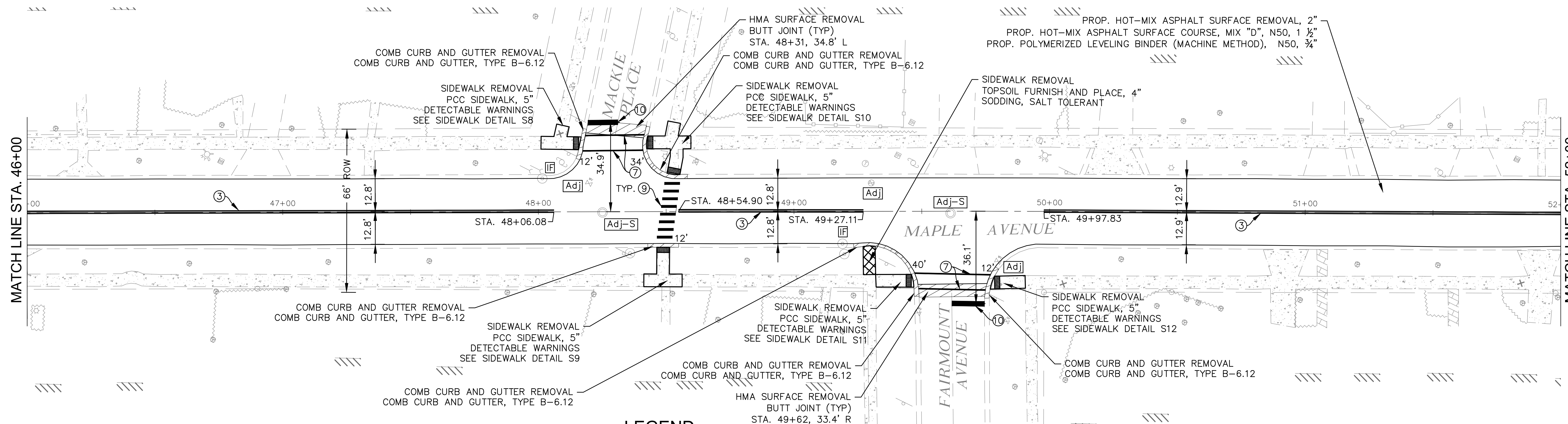
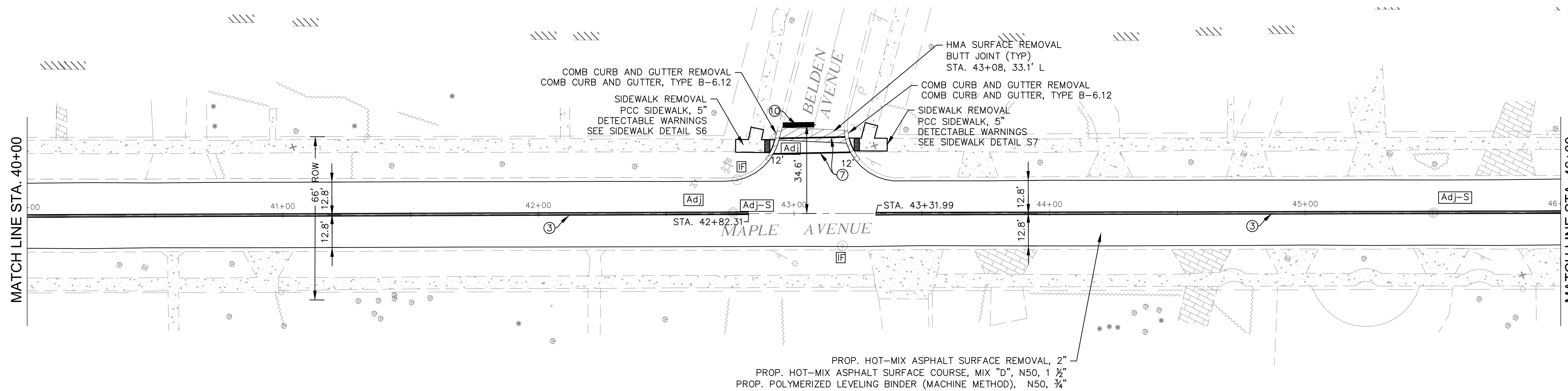
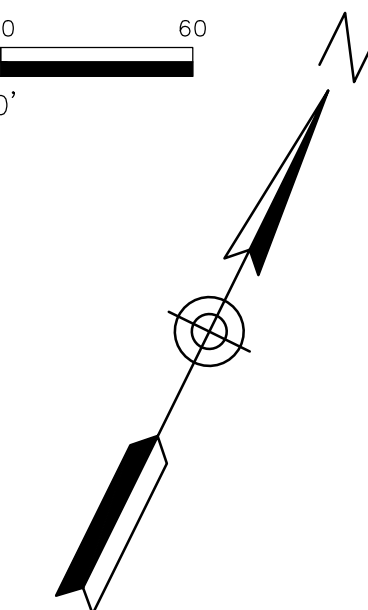

NOTES

1. CLASS D PATCHES, 4" OR 6" AS DIRECTED BY THE ENGINEER.
2. ALL EXISTING DRAINAGE STRUCTURES WHICH ARE TO BE ADJUSTED SHALL BE CLEANED IN ACCORDANCE WITH ARTICLE 602.15 OF THE STANDARD SPECIFICATIONS. THE COST OF THIS WORK SHALL BE INCLUDED IN THE COST OF THE ADJUSTMENT ITEM.
3. TOPSOIL, SODDING LOCATION/PLACEMENT AS DIRECTED BY THE ENGINEER.
4. ALL CURB AND GUTTER TO MATCH EXISTING EDGE OF PAVEMENT UNLESS OTHERWISE NOTED.
5. SIDEWALK REPLACEMENT NOT SHOWN ON PLANS TO BE COMPLETED BY OTHERS.

LEGEND

- Adj DRAINAGE & UTILITY STRUCTURES TO BE ADJUSTED
- Adj-S SANITARY STRUCTURE TO BE ADJUSTED SEE DETAIL ON SHEET 12
- IF INLET FILTERS
- REMOVE AND REPLACE EXISTING CURB AND GUTTER
- REMOVE EXISTING SIDEWALK

PAVEMENT MARKING LEGEND

NOTE: REPLACEMENT IN KIND (TYP.)

- ① 4" YELLOW THERMOPLASTIC LINE @ 5 3/4" C-C - SOLID
- ② 4" YELLOW THERMOPLASTIC LINE @ 5 1/2" C-C - SKIP DASH
- ③ 4" DOUBLE YELLOW THERMOPLASTIC LINE @ 11" C-C - SOLID
- ④ 4" YELLOW THERMOPLASTIC LINE - SOLID
- ⑤ 4" WHITE THERMOPLASTIC LINE - SOLID
- ⑥ 6" WHITE THERMOPLASTIC LINE - 2' DASH 6' SKIP
- ⑦ 6" WHITE THERMOPLASTIC LINE - SOLID
- ⑧ 12" YELLOW THERMOPLASTIC LINE - SOLID
- ⑨ 12" WHITE THERMOPLASTIC LINE - SOLID
- ⑩ 24" WHITE THERMOPLASTIC LINE - SOLID
- ⑪ LETTERS AND SYMBOLS - FULL SIZE

FILE NAME =	USER NAME - USER	DESIGNED - NRH	REVISED
FILE NAME =		DRAWN - NRH	REVISED
	PLOT SCALE -	CHECKED - JPT	REVISED
	PLOT DATE - 04/19/18	DATE - 04/19/18	REVISED

STATE OF ILLINOIS
DEPARTMENT OF TRANSPORTATION

MAPLE AVENUE IMPROVEMENTS
IMPROVEMENT PLAN

SCALE: 1"=20' SHEET NO. 2 OF 4 SHEETS STA. 40+00 TO STA. 52+00

F.A.U. RTE.	SECTION	COUNTY	TOTAL SHEETS	SHEET NO.
1487	18-00113-00-RS	DUPAGE	19	7
CONTRACT NO. 61E92				
FED. ROAD DIST. NO. 1 ILLINOIS FED. AID PROJECT				

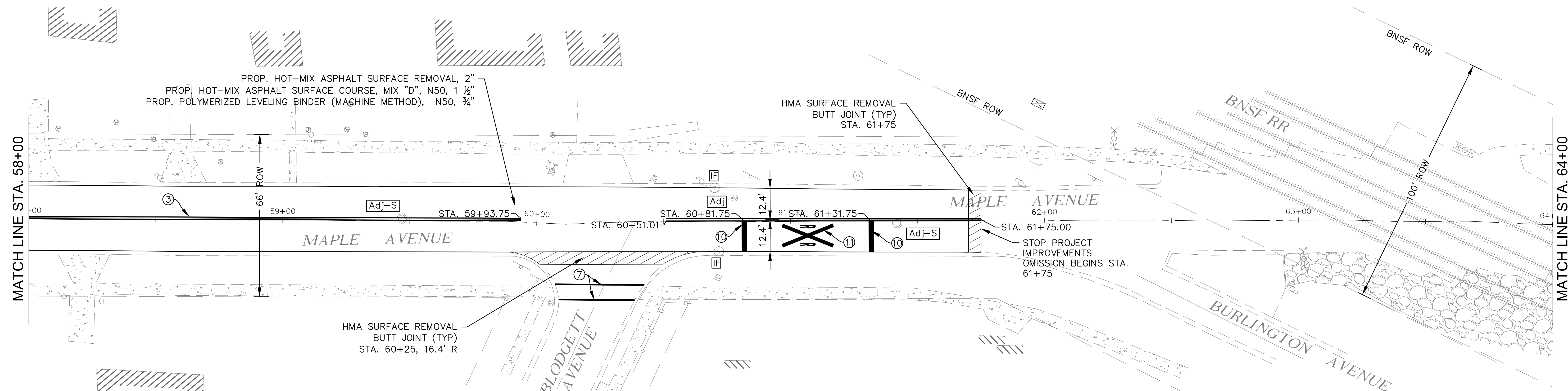
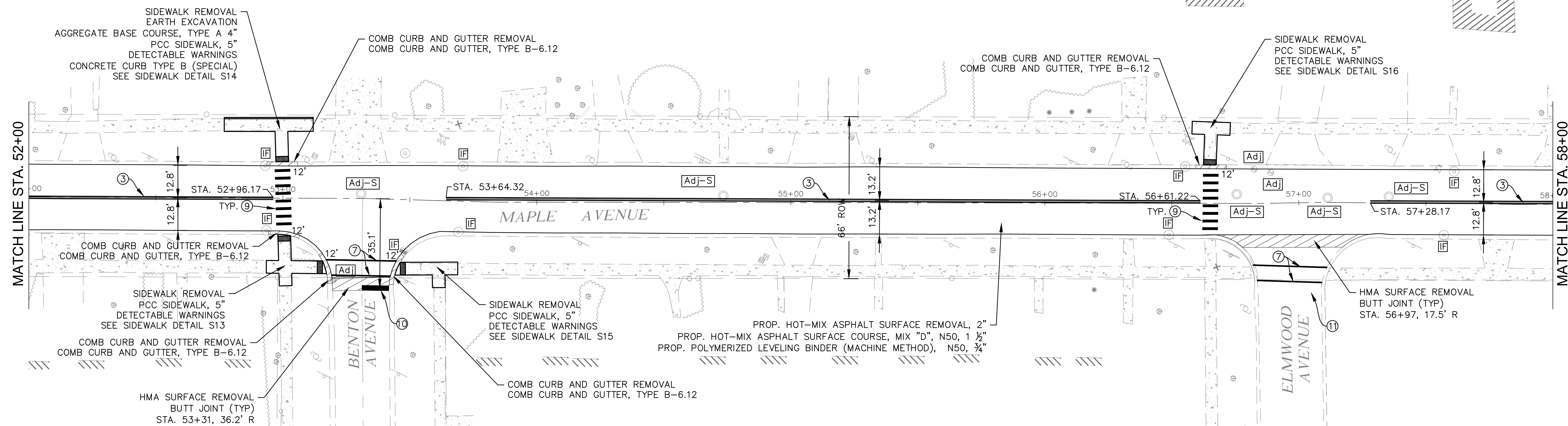
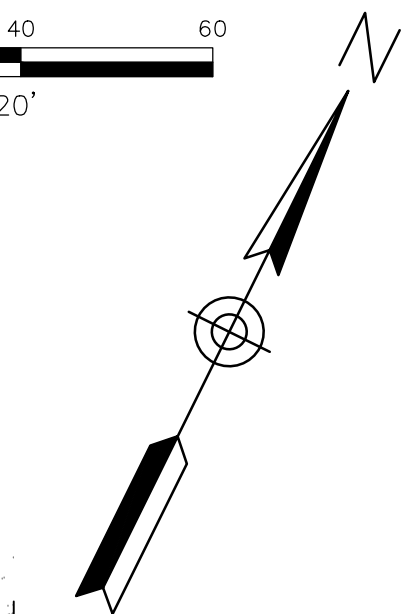

NOTES

1. CLASS D PATCHES, 4" OR 6" AS DIRECTED BY THE ENGINEER.
2. ALL EXISTING DRAINAGE STRUCTURES WHICH ARE TO BE ADJUSTED SHALL BE CLEANED IN ACCORDANCE WITH ARTICLE 602.15 OF THE STANDARD SPECIFICATIONS. THE COST OF THIS WORK SHALL BE INCLUDED IN THE COST OF THE ADJUSTMENT ITEM.
3. TOPSOIL, SODDING LOCATION/PLACEMENT AS DIRECTED BY THE ENGINEER.
4. ALL CURB AND GUTTER TO MATCH EXISTING EDGE OF PAVEMENT UNLESS OTHERWISE NOTED.
5. SIDEWALK REPLACEMENT NOT SHOWN ON PLANS TO BE COMPLETED BY OTHERS.

LEGEND

- [Adj] DRAINAGE & UTILITY STRUCTURES TO BE ADJUSTED
- [Adj-S] SANITARY STRUCTURE TO BE ADJUSTED SEE DETAIL ON SHEET 12
- [IF] INLET FILTERS
- [Hatched] REMOVE AND REPLACE EXISTING CURB AND GUTTER
- [X] REMOVE EXISTING SIDEWALK

PAVEMENT MARKING LEGEND

NOTE: REPLACEMENT IN KIND (TYP.)

- ① 4" YELLOW THERMOPLASTIC LINE @ 5 1/2" C-C - SOLID
- ② 4" YELLOW THERMOPLASTIC LINE @ 5 1/2" C-C - SKIP DASH
- ③ 4" DOUBLE YELLOW THERMOPLASTIC LINE @ 11" C-C - SOLID
- ④ 4" YELLOW THERMOPLASTIC LINE - SOLID
- ⑤ 4" WHITE THERMOPLASTIC LINE - SOLID
- ⑥ 6" WHITE THERMOPLASTIC LINE - 2' DASH 6' SKIP
- ⑦ 6" WHITE THERMOPLASTIC LINE - SOLID
- ⑧ 12" YELLOW THERMOPLASTIC LINE - SOLID
- ⑨ 12" WHITE THERMOPLASTIC LINE - SOLID
- ⑩ 24" WHITE THERMOPLASTIC LINE - SOLID
- ⑪ LETTERS AND SYMBOLS - FULL SIZE

FILE NAME =	USER NAME - USER	DESIGNED - NRH	REVISED
FILE NAME =		DRAWN - NRH	REVISED
	PLOT SCALE -	CHECKED - JPT	REVISED
	PLOT DATE - 06/07/18	DATE - 06/07/18	REVISED

STATE OF ILLINOIS
DEPARTMENT OF TRANSPORTATION

MAPLE AVENUE IMPROVEMENTS
IMPROVEMENT PLAN

SCALE: 1"=20' SHEET NO. 3 OF 4 SHEETS STA. 52+00 TO STA. 64+00

F.A.U. RTE.	SECTION	COUNTY	TOTAL SHEETS	SHEET NO.
1487	18-00113-00-RS	DUPAGE	19	8
CONTRACT NO. 61E92				
FED. ROAD DIST. NO. 1		ILLINOIS	FED. AID PROJECT	

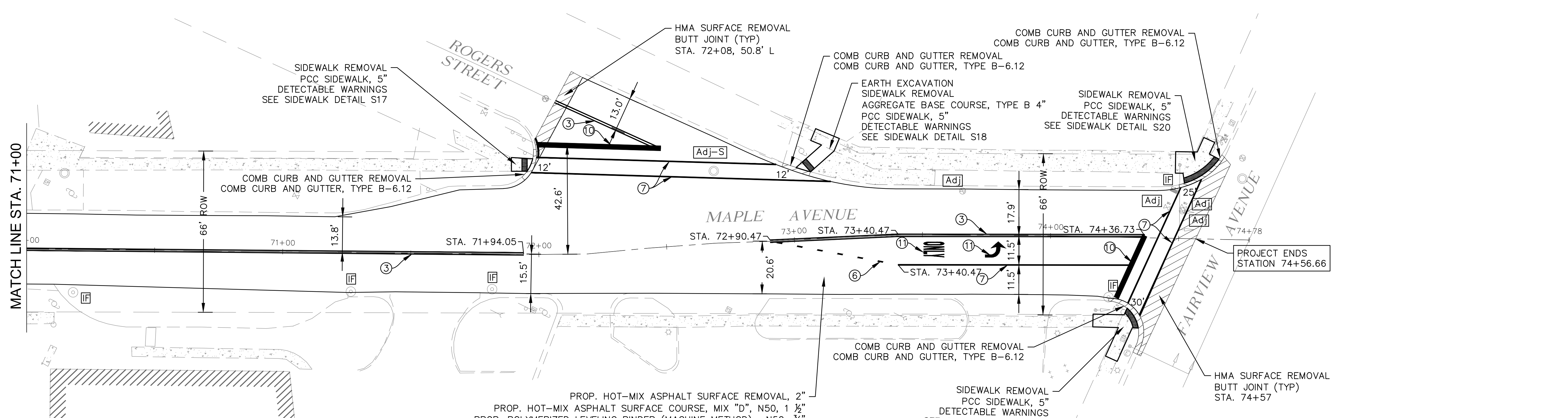
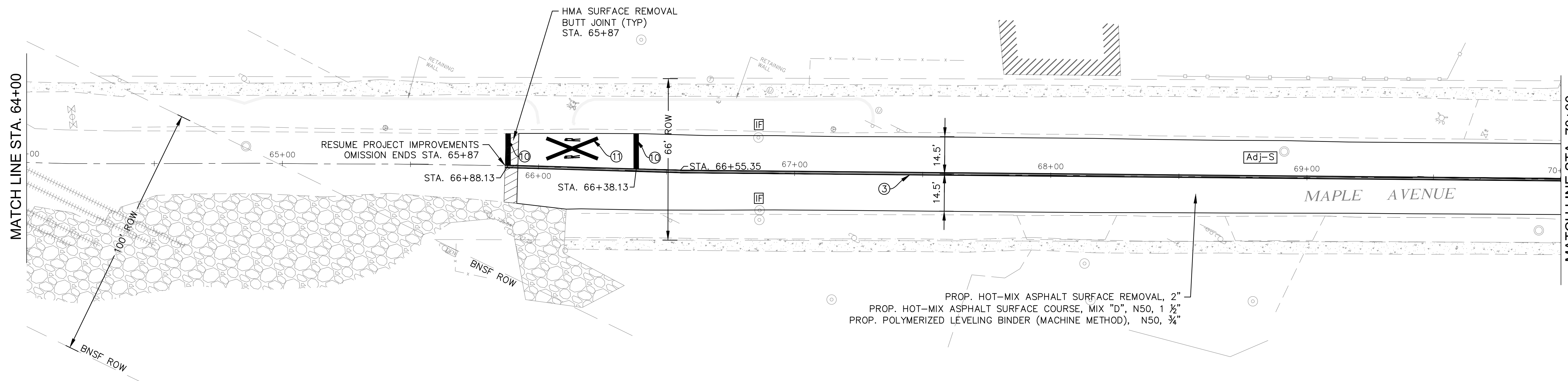
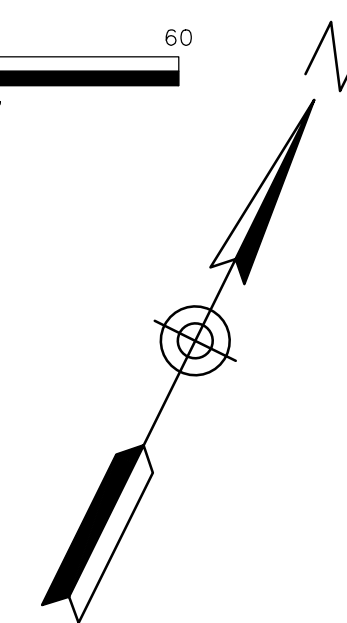

NOTES

1. CLASS D PATCHES, 4" OR 6" AS DIRECTED BY THE ENGINEER.
2. ALL EXISTING DRAINAGE STRUCTURES WHICH ARE TO BE ADJUSTED SHALL BE CLEANED IN ACCORDANCE WITH ARTICLE 602.15 OF THE STANDARD SPECIFICATIONS. THE COST OF THIS WORK SHALL BE INCLUDED IN THE COST OF THE ADJUSTMENT ITEM.
3. TOPSOIL, SODDING LOCATION/PLACEMENT AS DIRECTED BY THE ENGINEER.
4. ALL CURB AND GUTTER TO MATCH EXISTING EDGE OF PAVEMENT UNLESS OTHERWISE NOTED.
5. SIDEWALK REPLACEMENT NOT SHOWN ON PLANS TO BE COMPLETED BY OTHERS.

LEGEND

- Adj DRAINAGE & UTILITY STRUCTURES TO BE ADJUSTED
- Adj-S SANITARY STRUCTURE TO BE ADJUSTED SEE DETAIL ON SHEET 12
- IF INLET FILTERS
- / REMOVE AND REPLACE EXISTING CURB AND GUTTER
- X REMOVE EXISTING SIDEWALK

PAVEMENT MARKING LEGEND

NOTE: REPLACEMENT IN KIND (TYP.)

- ① 4" YELLOW THERMOPLASTIC LINE @ 5 1/2" C-C - SOLID
- ② 4" YELLOW THERMOPLASTIC LINE @ 5 1/2" C-C - SKIP DASH
- ③ 4" DOUBLE YELLOW THERMOPLASTIC LINE @ 11" C-C - SOLID
- ④ 4" YELLOW THERMOPLASTIC LINE - SOLID
- ⑤ 4" WHITE THERMOPLASTIC LINE - SOLID
- ⑥ 6" WHITE THERMOPLASTIC LINE - 2' DASH 6' SKIP
- ⑦ 6" WHITE THERMOPLASTIC LINE - SOLID
- ⑧ 12" YELLOW THERMOPLASTIC LINE - SOLID
- ⑨ 12" WHITE THERMOPLASTIC LINE - SOLID
- ⑩ 24" WHITE THERMOPLASTIC LINE - SOLID
- ⑪ LETTERS AND SYMBOLS - FULL SIZE

FILE NAME =	USER NAME - USER	DESIGNED - NRH	REVISED
FILE NAME =		DRAWN - NRH	REVISED
	PLOT SCALE -	CHECKED - JPT	REVISED
	PLOT DATE - 04/19/18	DATE - 04/19/18	REVISED

STATE OF ILLINOIS
DEPARTMENT OF TRANSPORTATION

MAPLE AVENUE IMPROVEMENTS
IMPROVEMENT PLAN

SCALE: 1"=20' SHEET NO. 4 OF 4 SHEETS STA. 64+00 TO STA. 74+78

F.A.U. RTE.	SECTION	COUNTY	TOTAL SHEETS	SHEET NO.
1487	18-00113-00-RS	DUPAGE	19	9
CONTRACT NO. 61E92				
FED. ROAD DIST. NO. 1	ILLINOIS	FED. AID PROJECT		

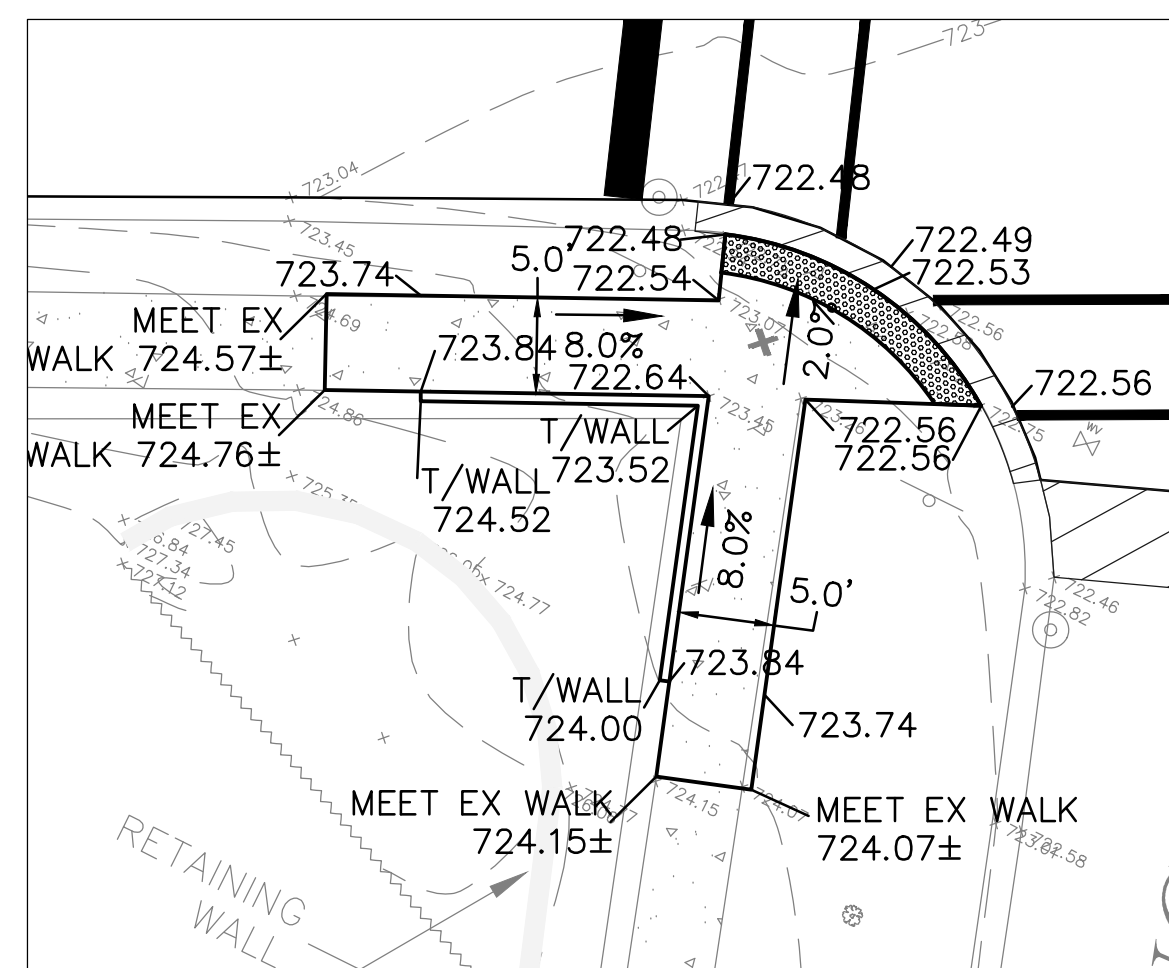

**SIDEWALK DETAIL S1
STA 35+78 - RIGHT SIDE**

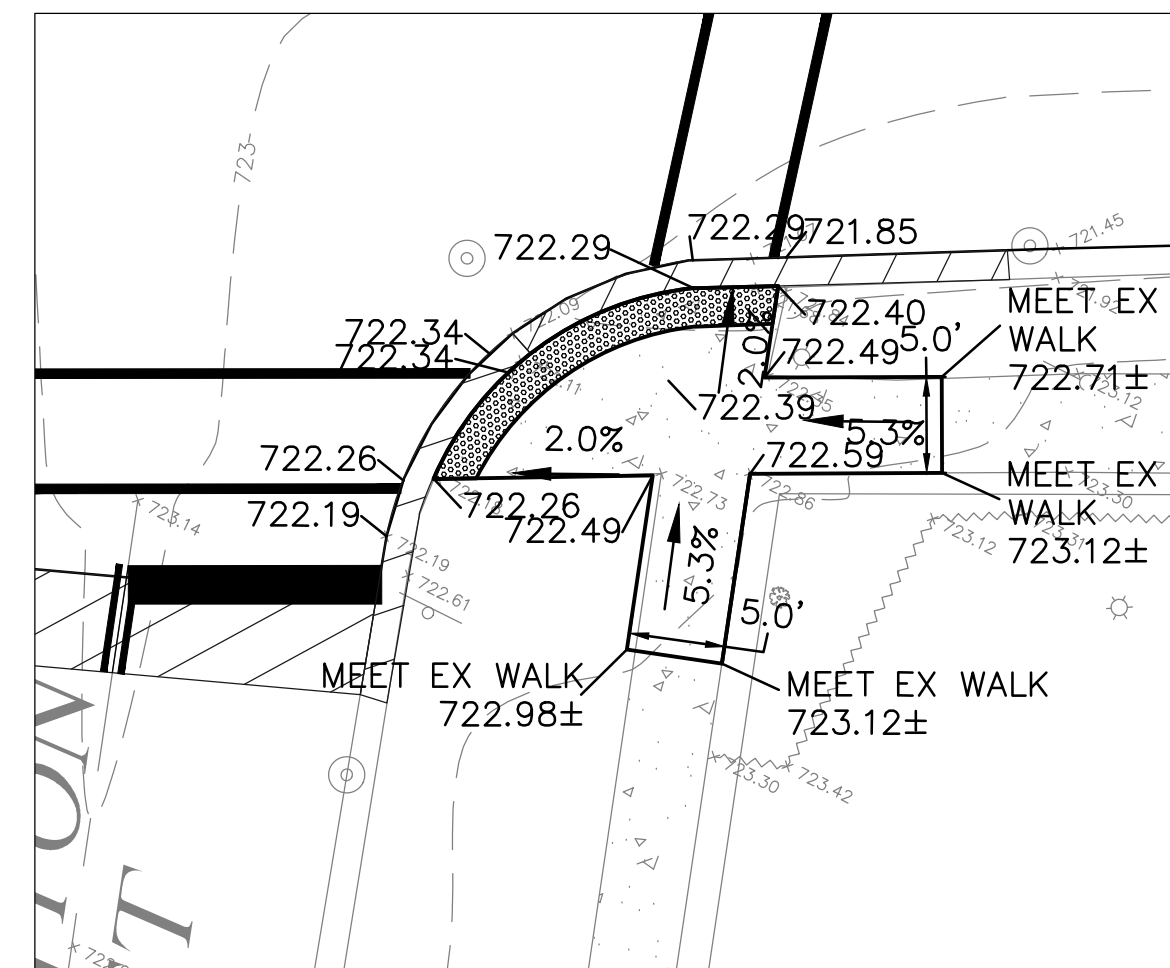

**SIDEWALK DETAIL S2
STA 36+25 - RIGHT SIDE**

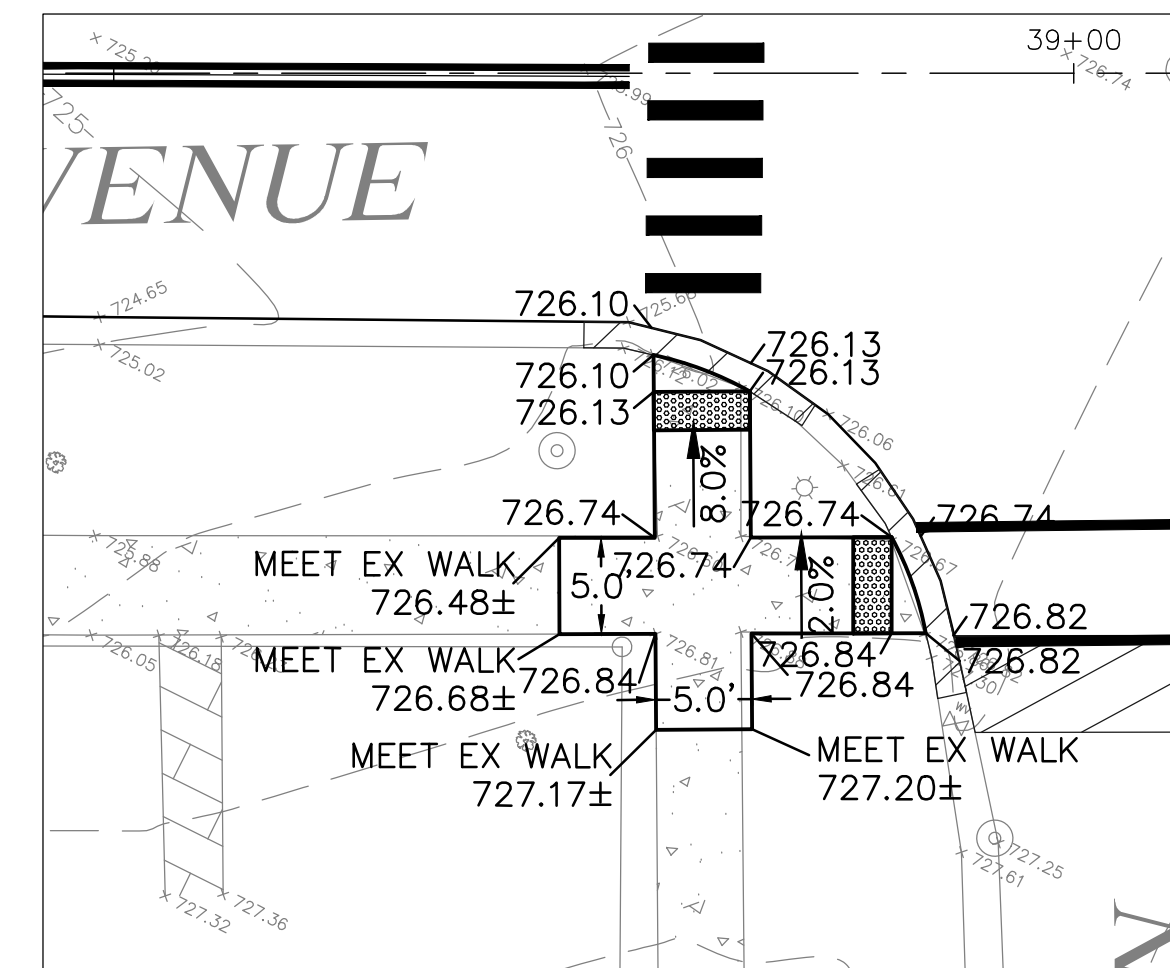

**SIDEWALK DETAIL S3
STA 38+81 - RIGHT SIDE**

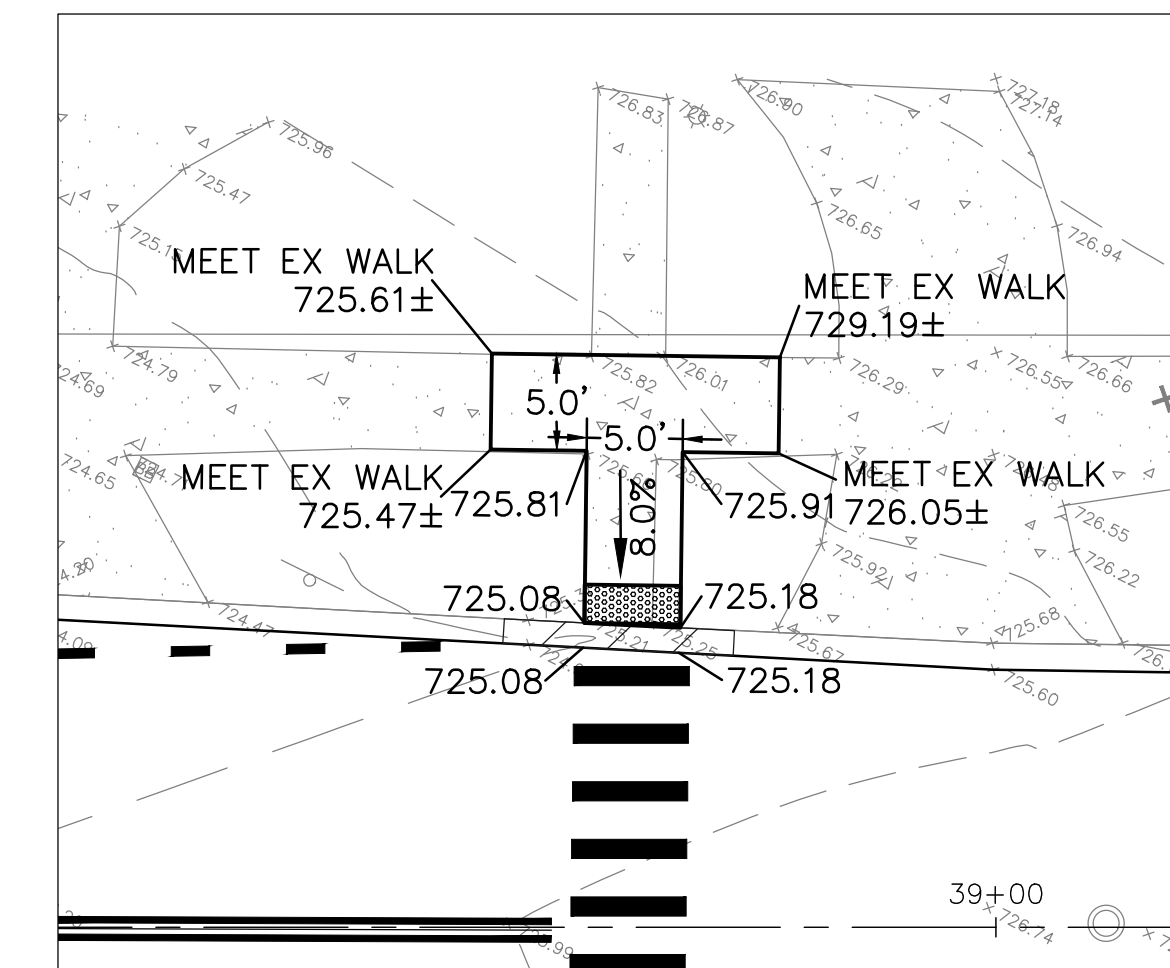

**SIDEWALK DETAIL S4
STA 38+81 - LEFT SIDE**

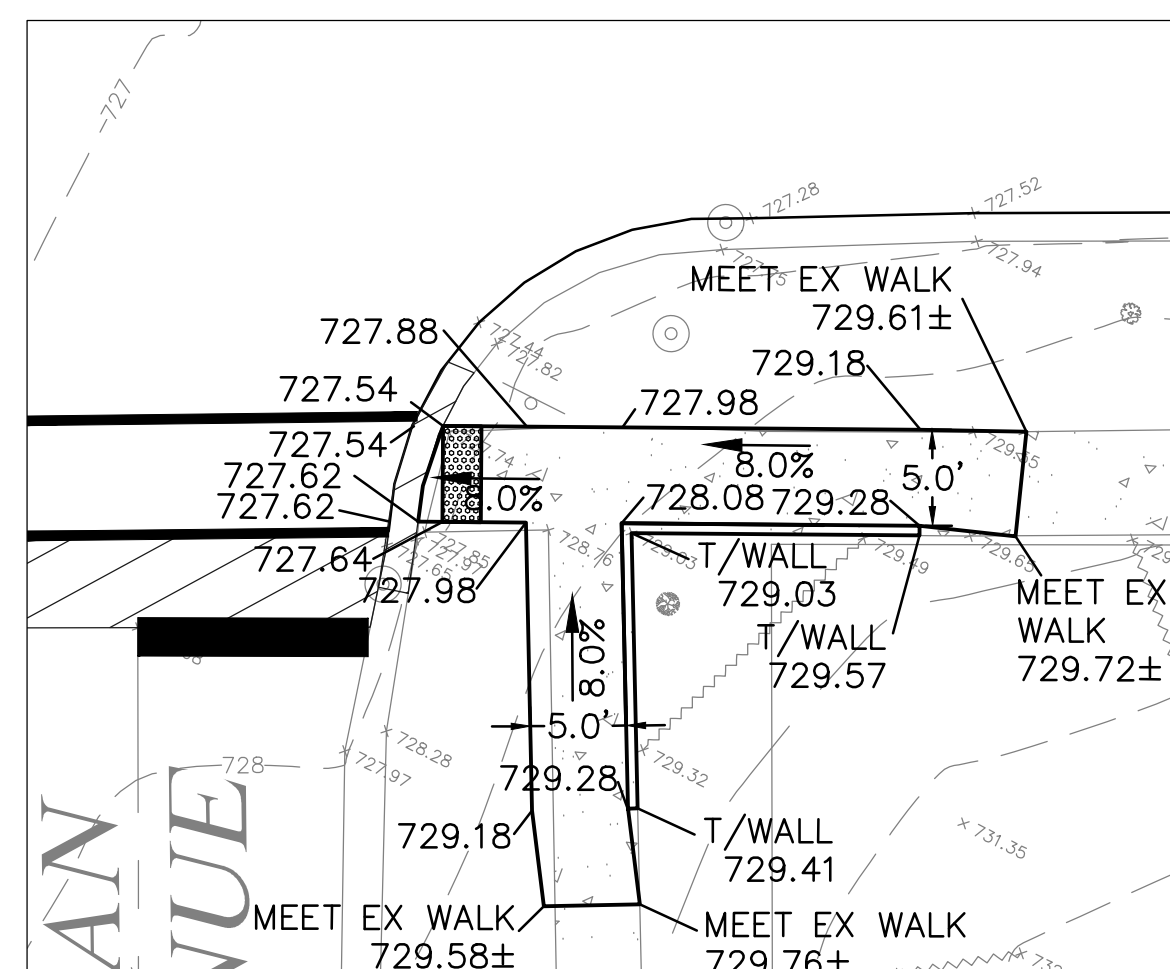

**SIDEWALK DETAIL S5
STA 39+30 - RIGHT SIDE**

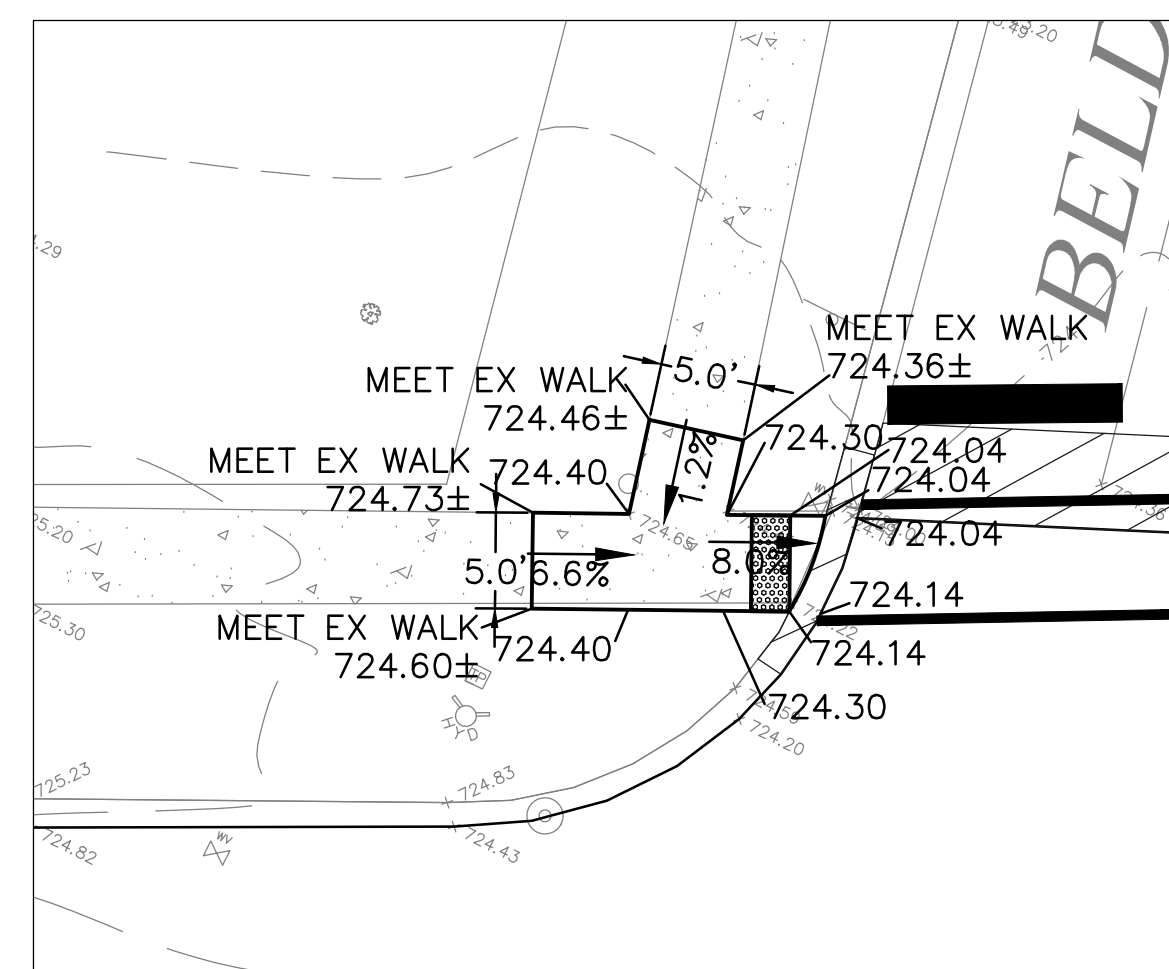

**SIDEWALK DETAIL S6
STA 42+85 - LEFT SIDE**

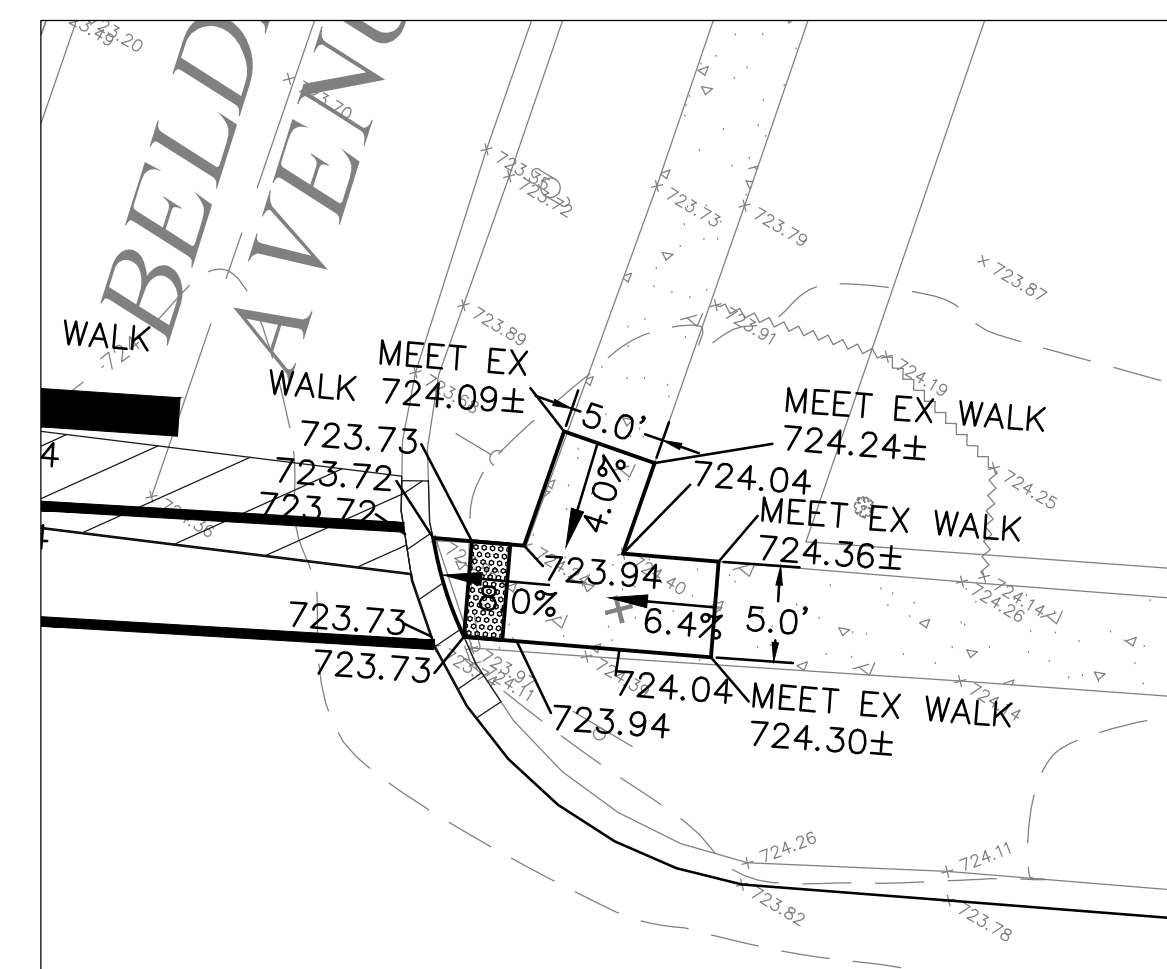

**SIDEWALK DETAIL S7
STA 43+29 - LEFT SIDE**

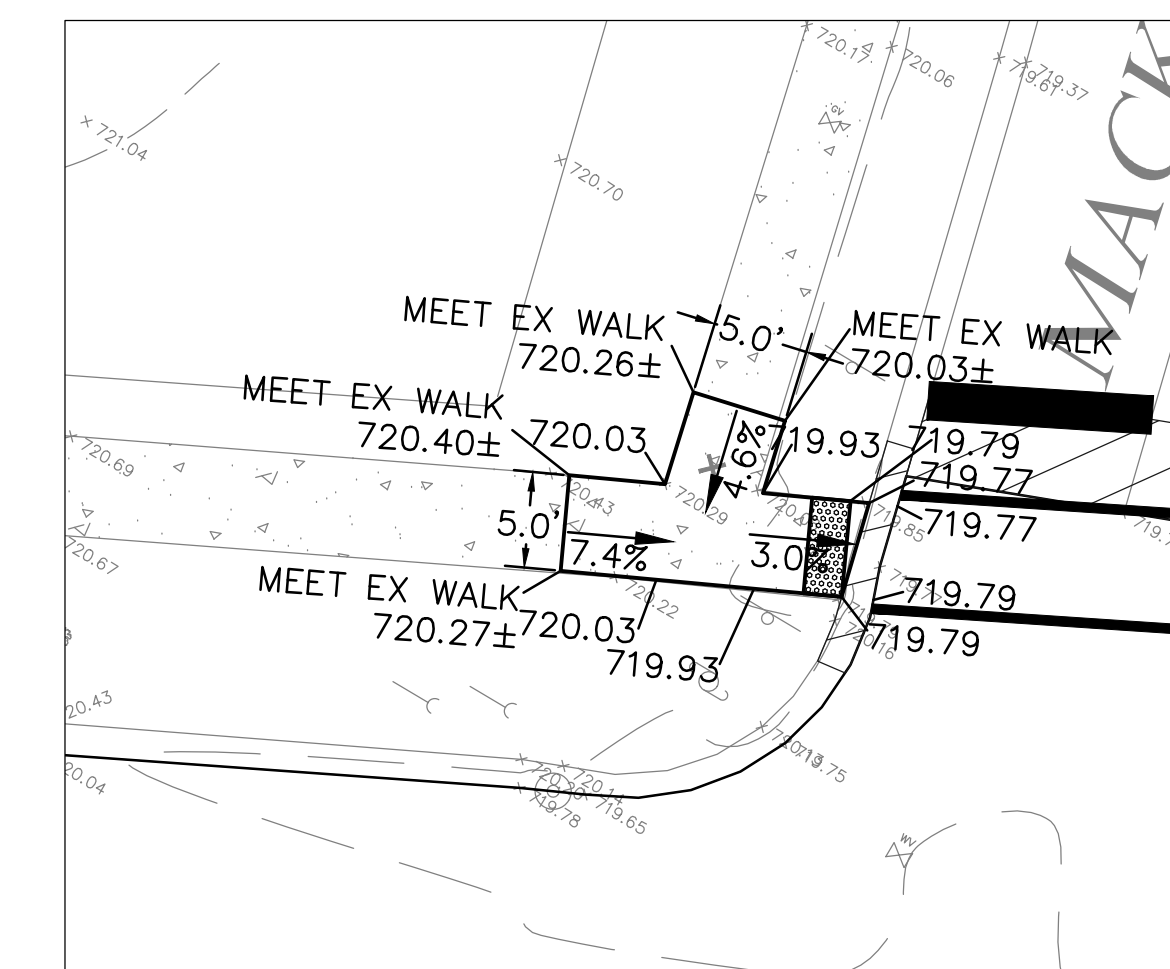

**SIDEWALK DETAIL S8
STA 48+08 - LEFT SIDE**

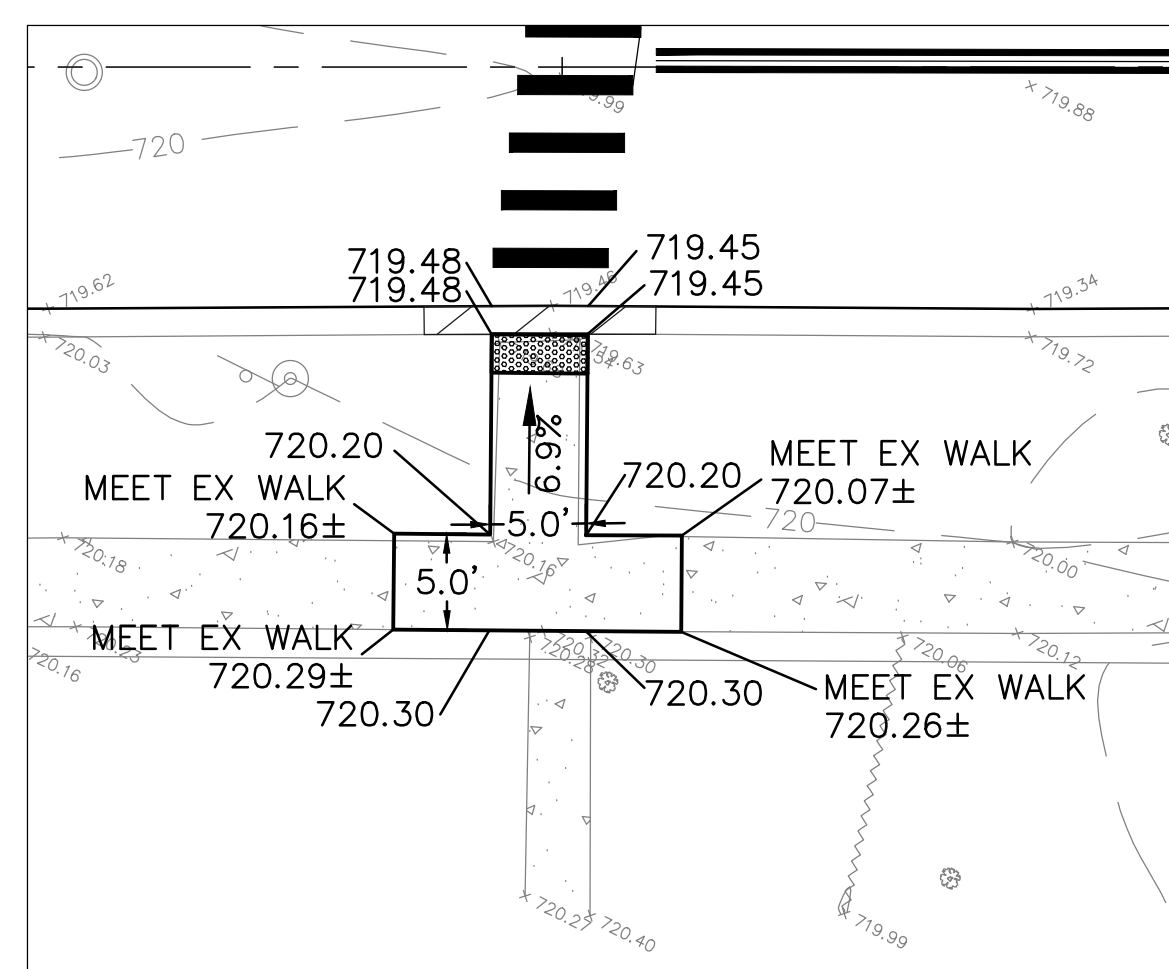

**SIDEWALK DETAIL S9
STA 48+49 - RIGHT SIDE**

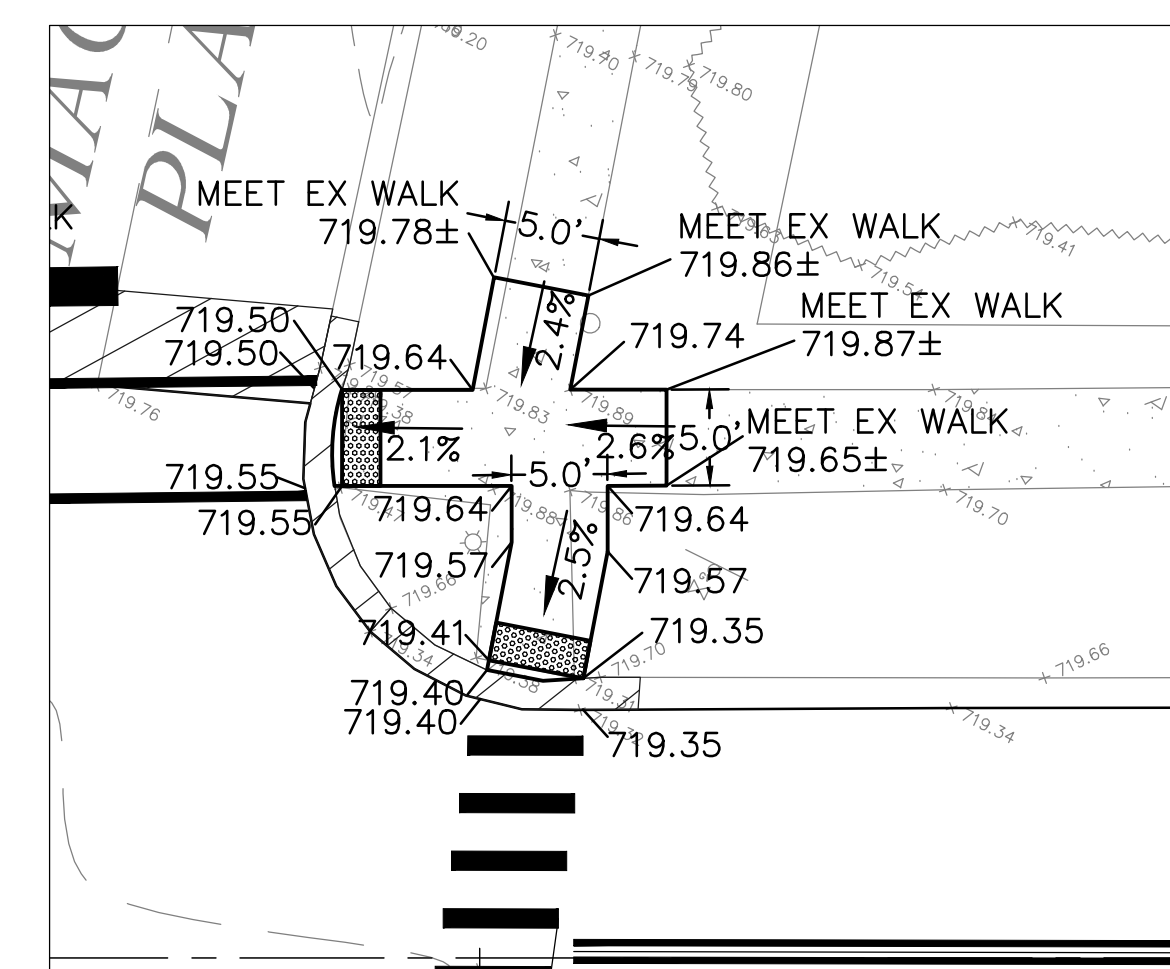

**SIDEWALK DETAIL S10
STA 48+53 - RIGHT SIDE**

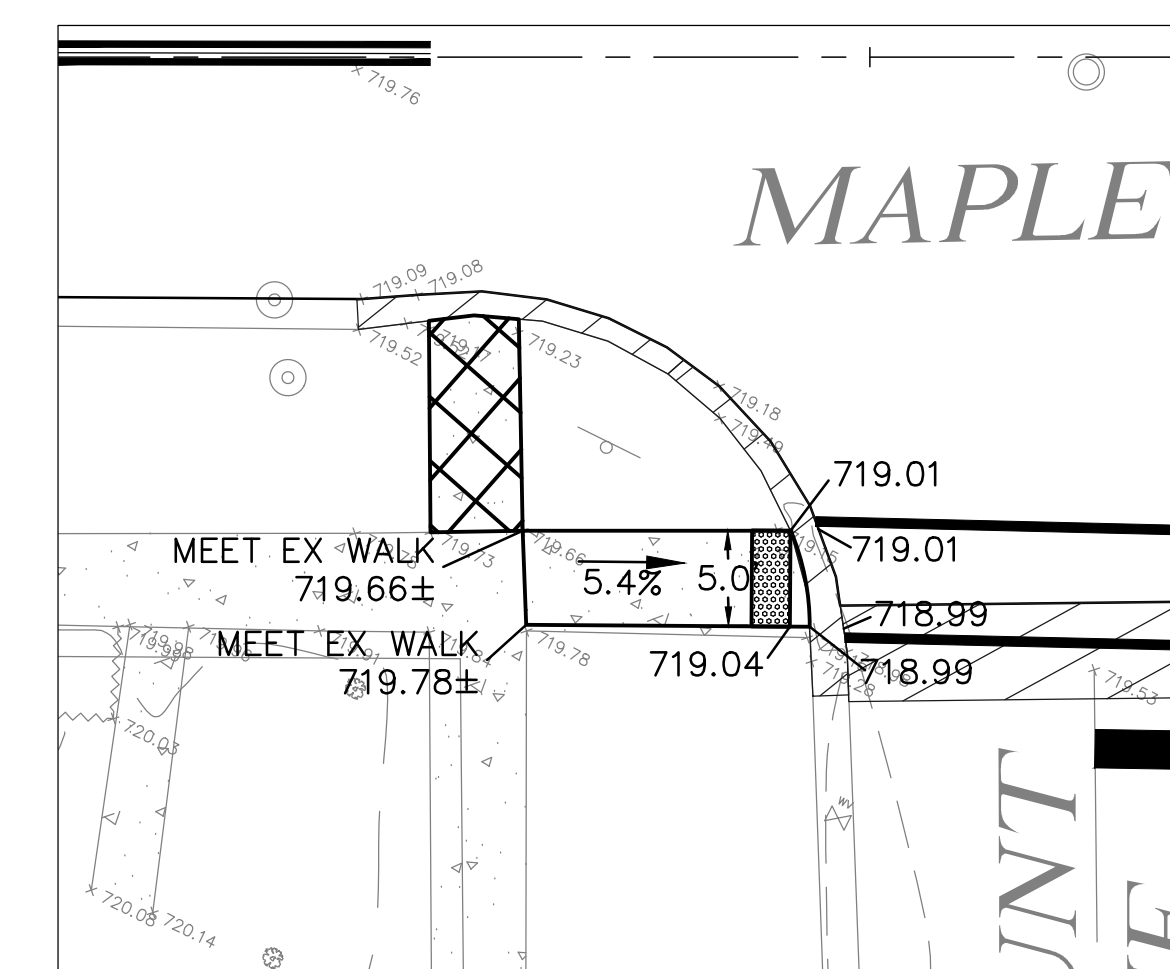

**SIDEWALK DETAIL S12
STA 49+40 - RIGHT SIDE**

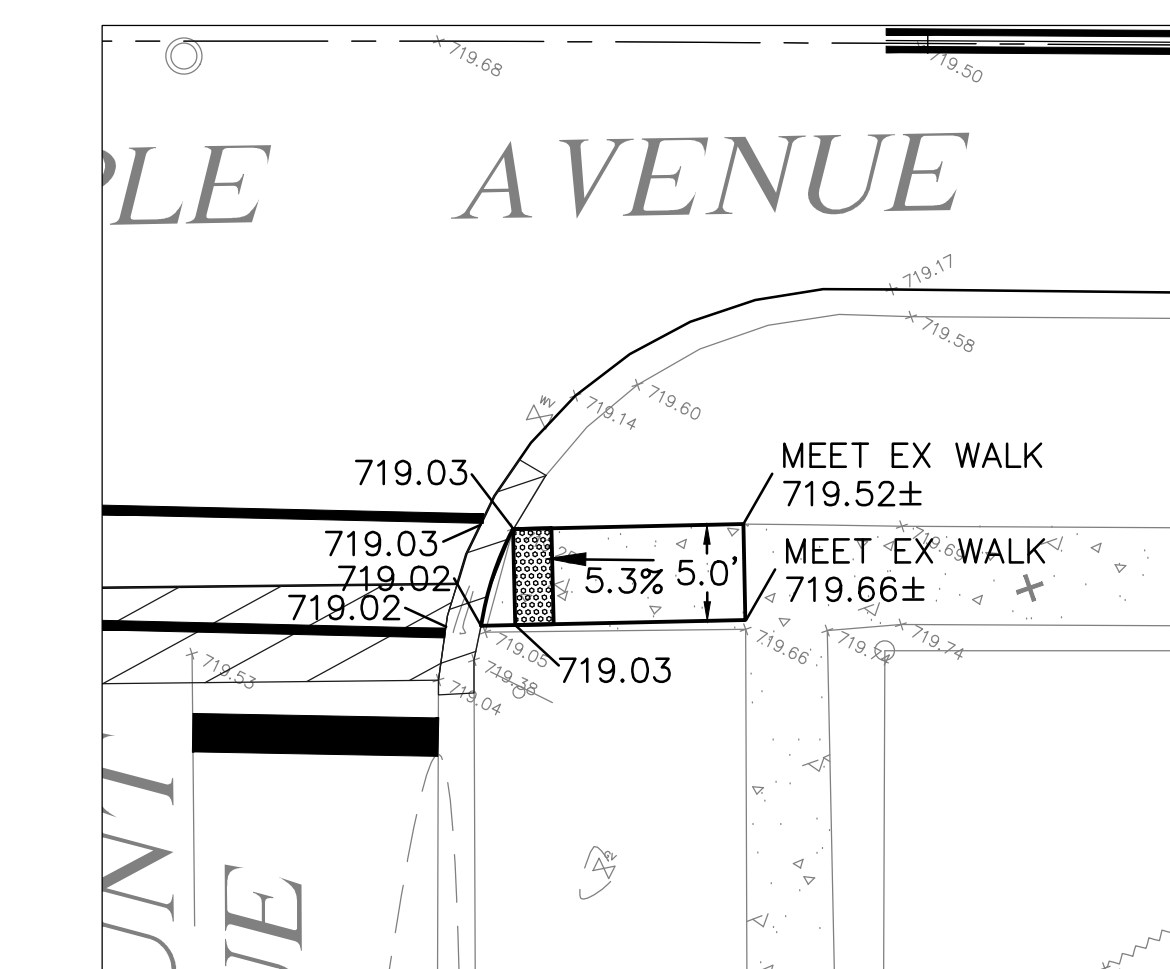

**SIDEWALK DETAIL S13
STA 49+84 - RIGHT SIDE**

FILE NAME =	USER NAME -- USER	DESIGNED -- NRH	REVISED
FILE NAME =		DRAWN -- NRH	REVISED
	PLOT SCALE --	CHECKED -- JPT	REVISED
	PLOT DATE -- 03/30/18	DATE -- 03/30/18	REVISED

STATE OF ILLINOIS
DEPARTMENT OF TRANSPORTATION

MAPLE AVENUE IMPROVEMENTS
SIDEWALK DETAILS

SCALE: 1"=10' SHEET NO. 1 OF 2 SHEETS STA. TO STA.

F.A.U. RTE.	SECTION	COUNTY	TOTAL SHEETS	SHEET NO.
1487	18-00113-00-RS	DUPAGE	19	10
CONTRACT NO. 61E92				
FED. ROAD DIST. NO. 1	ILLINOIS	FED. AID PROJECT		

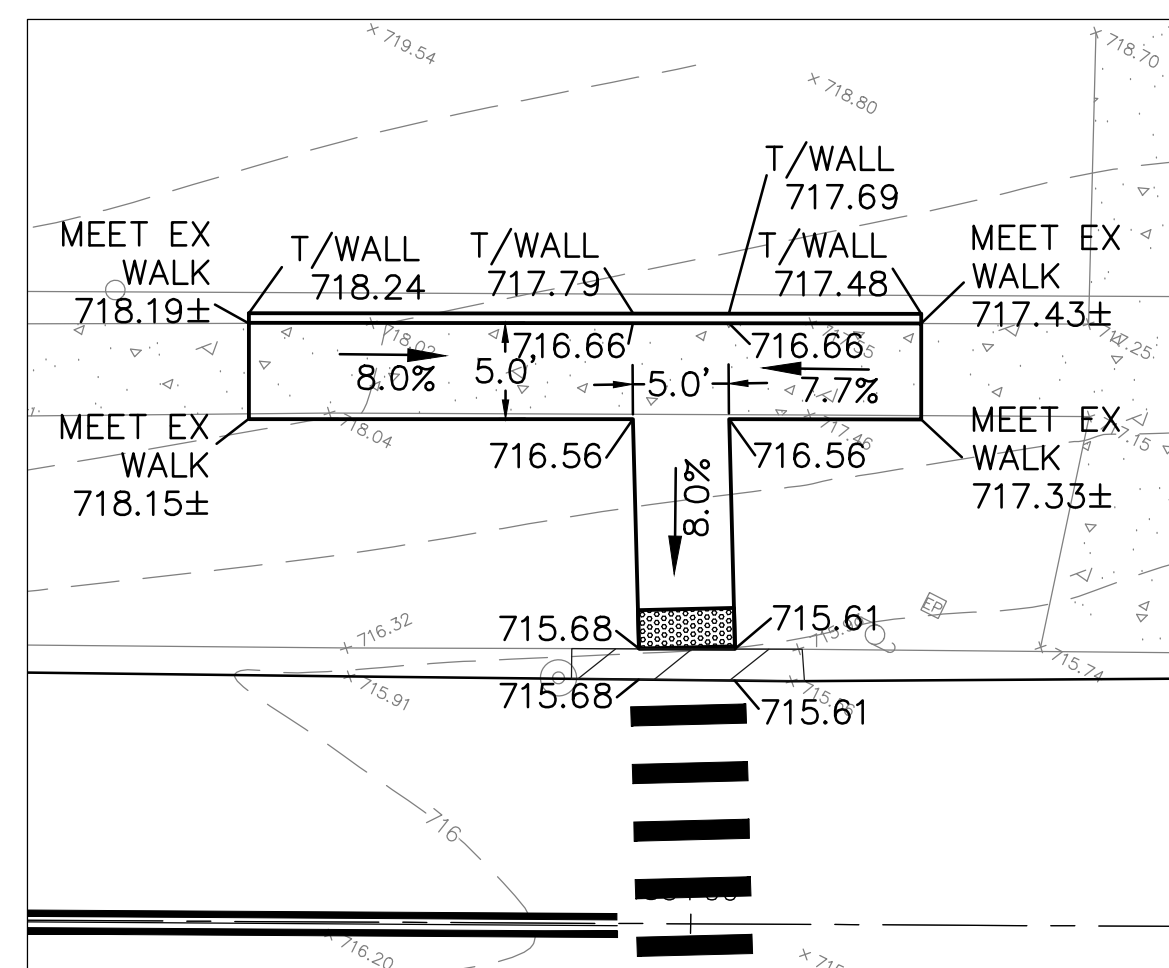
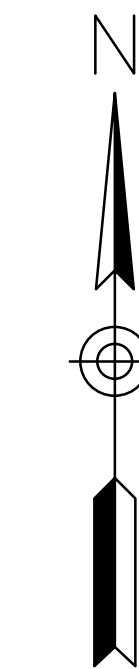

**SIDEWALK DETAIL S13
STA 53+00 - LEFT SIDE**

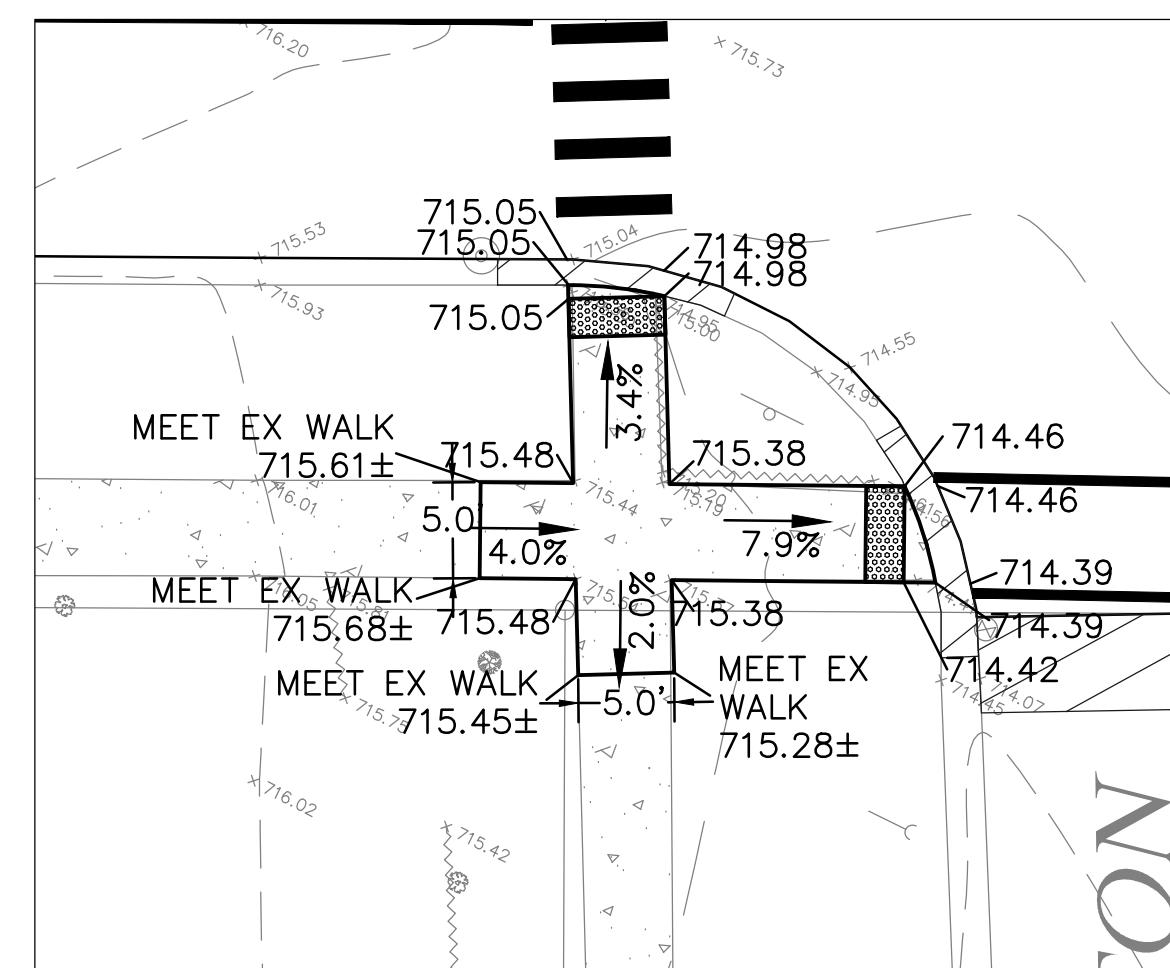

**SIDEWALK DETAIL S14
STA 53+00 - RIGHT SIDE**

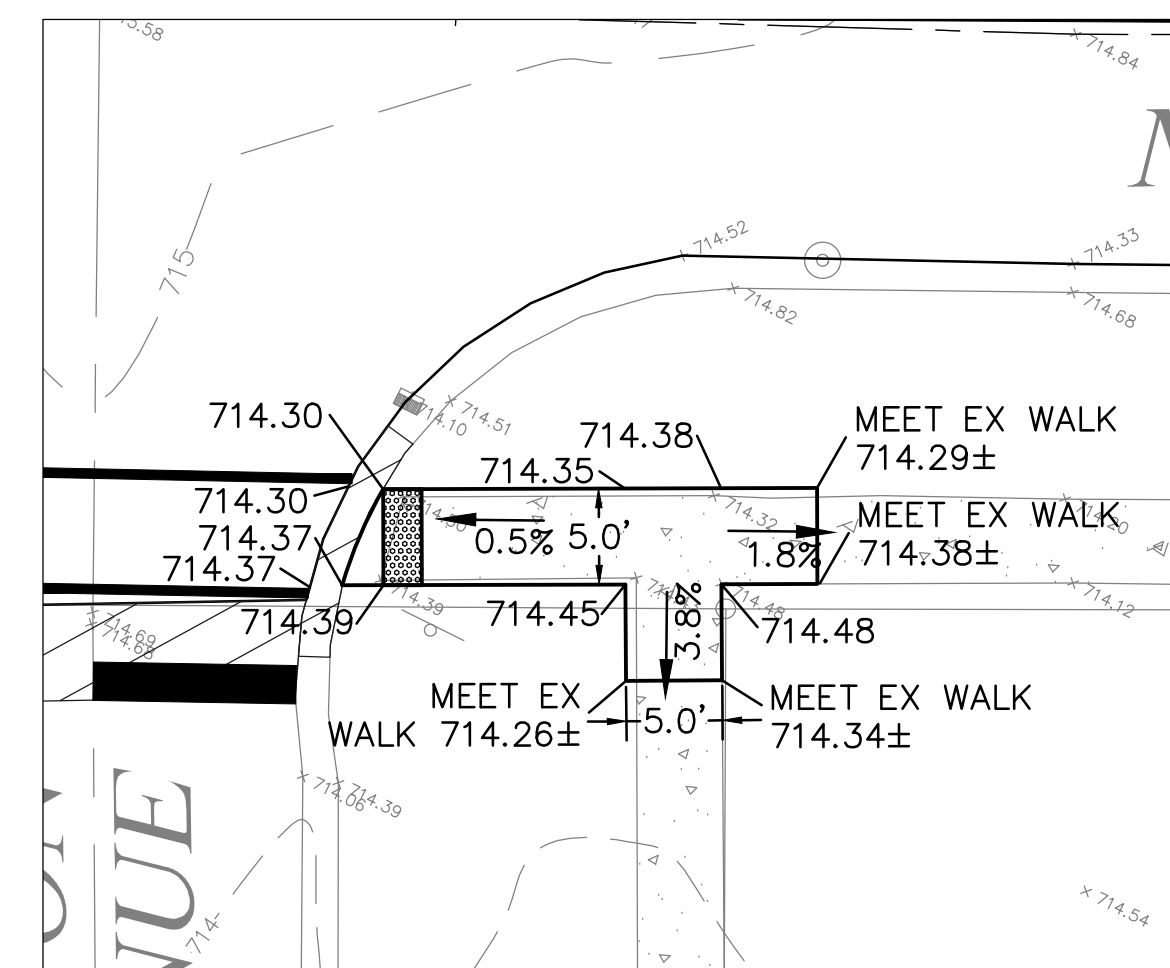

**SIDEWALK DETAIL S15
STA 53+63 - RIGHT SIDE**

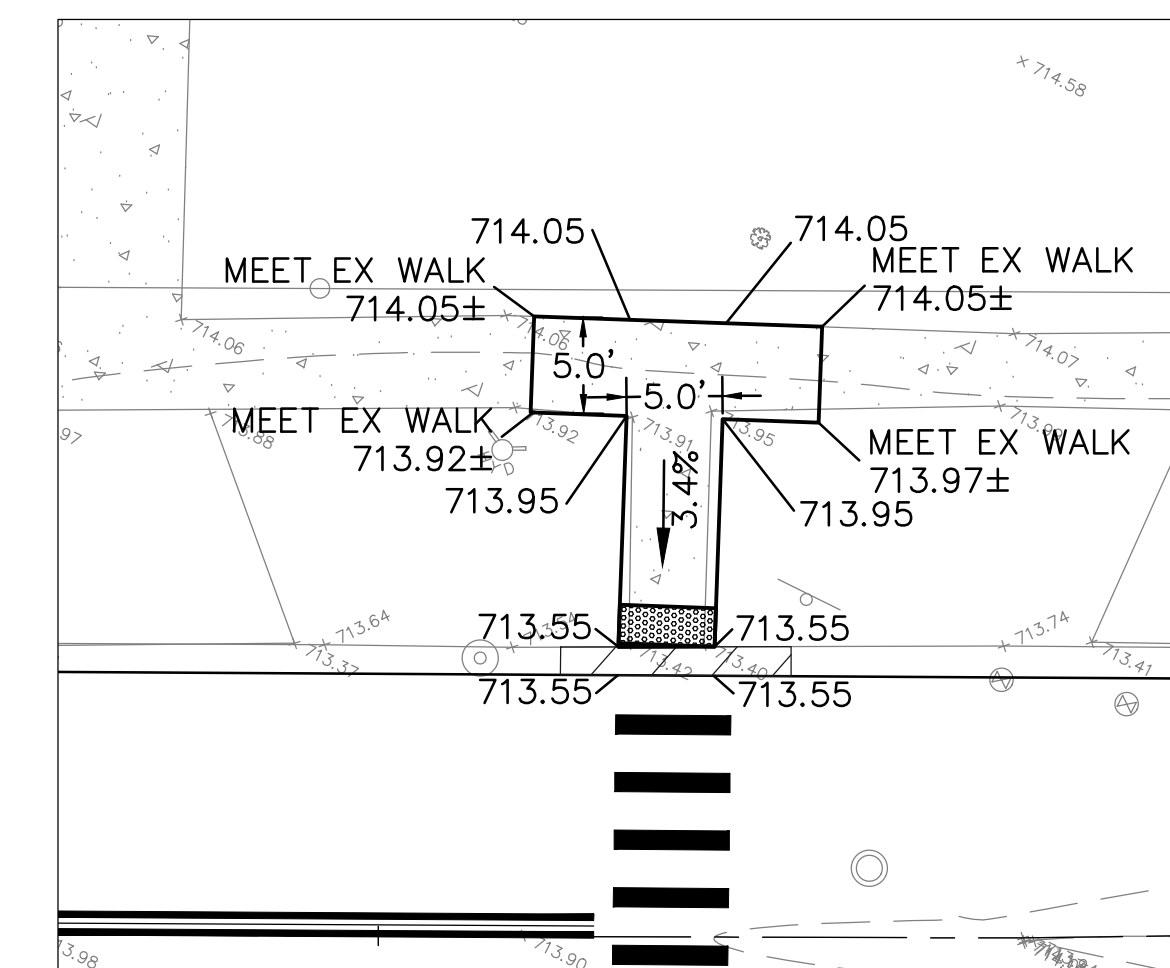

**SIDEWALK DETAIL S16
STA 56+65 - LEFT SIDE**

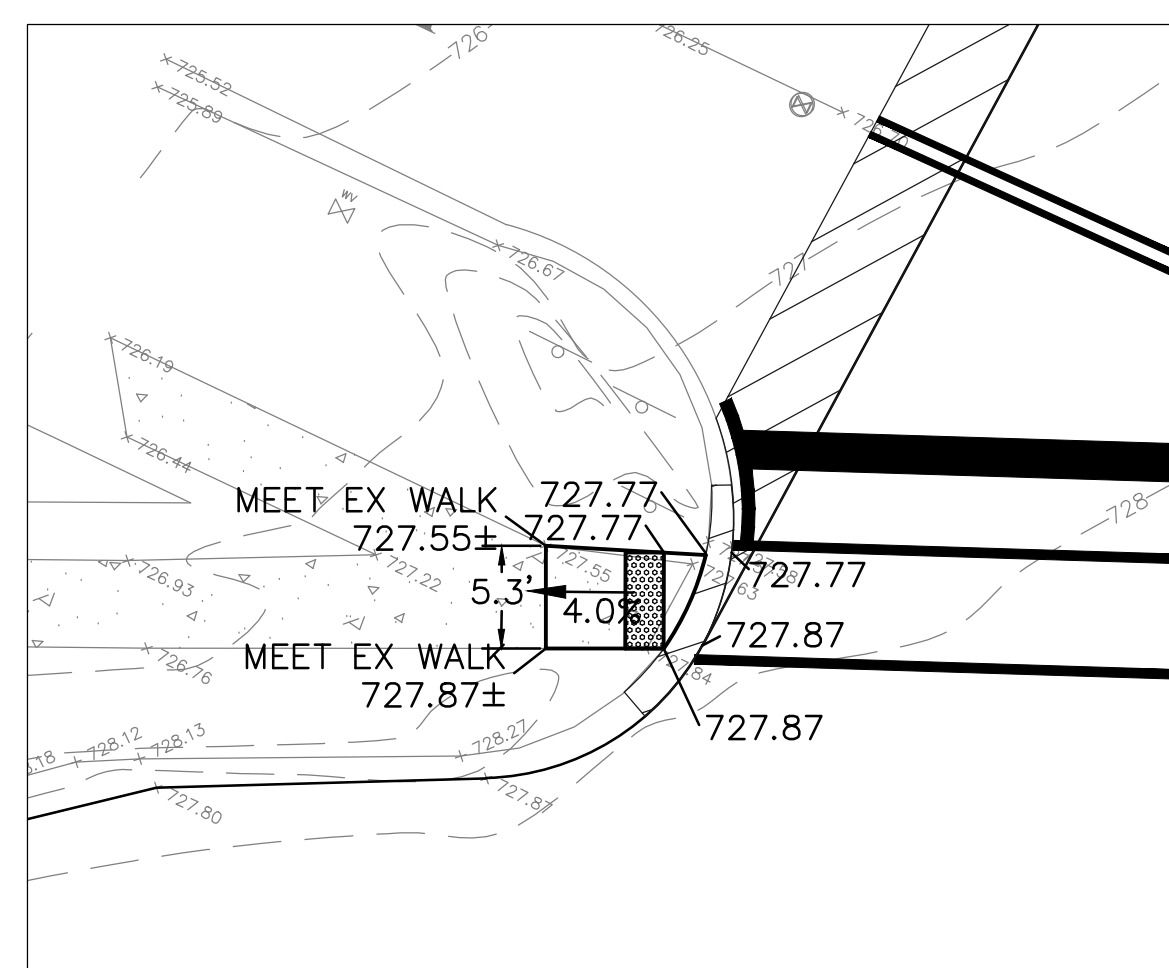

**SIDEWALK DETAIL S17
STA 71+92 - LEFT SIDE**

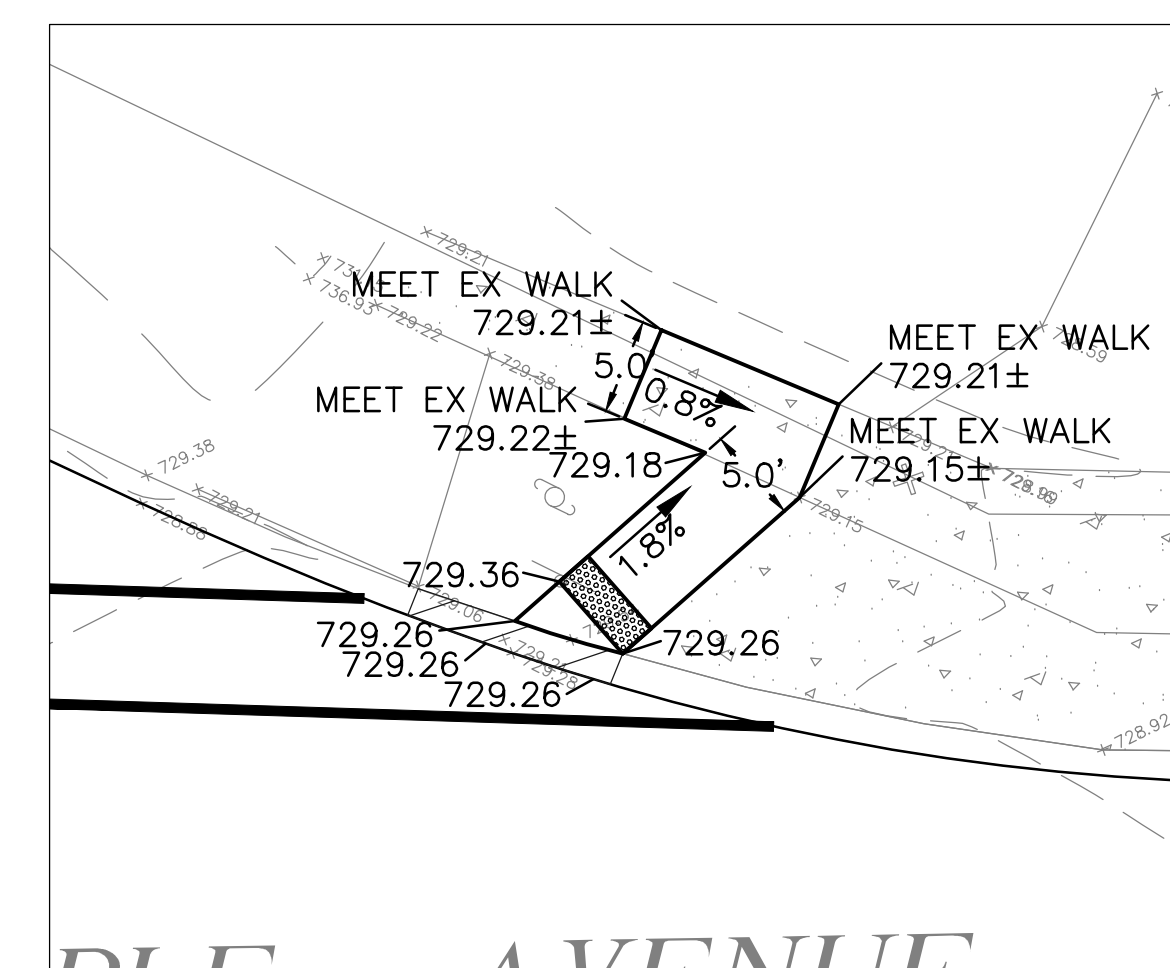

**SIDEWALK DETAIL S18
STA 73+11 - LEFT SIDE**

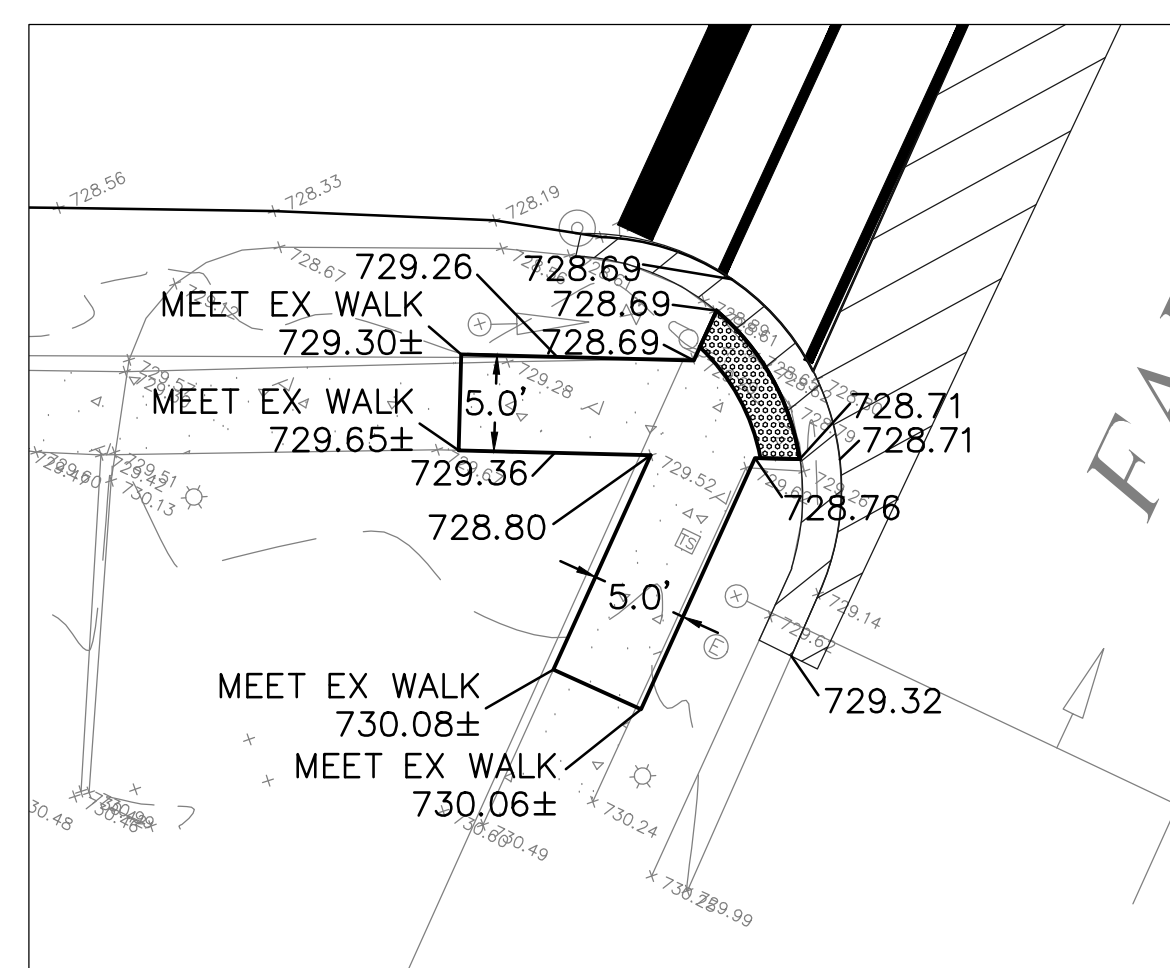

**SIDEWALK DETAIL S19
STA 74+33 - RIGHT SIDE**

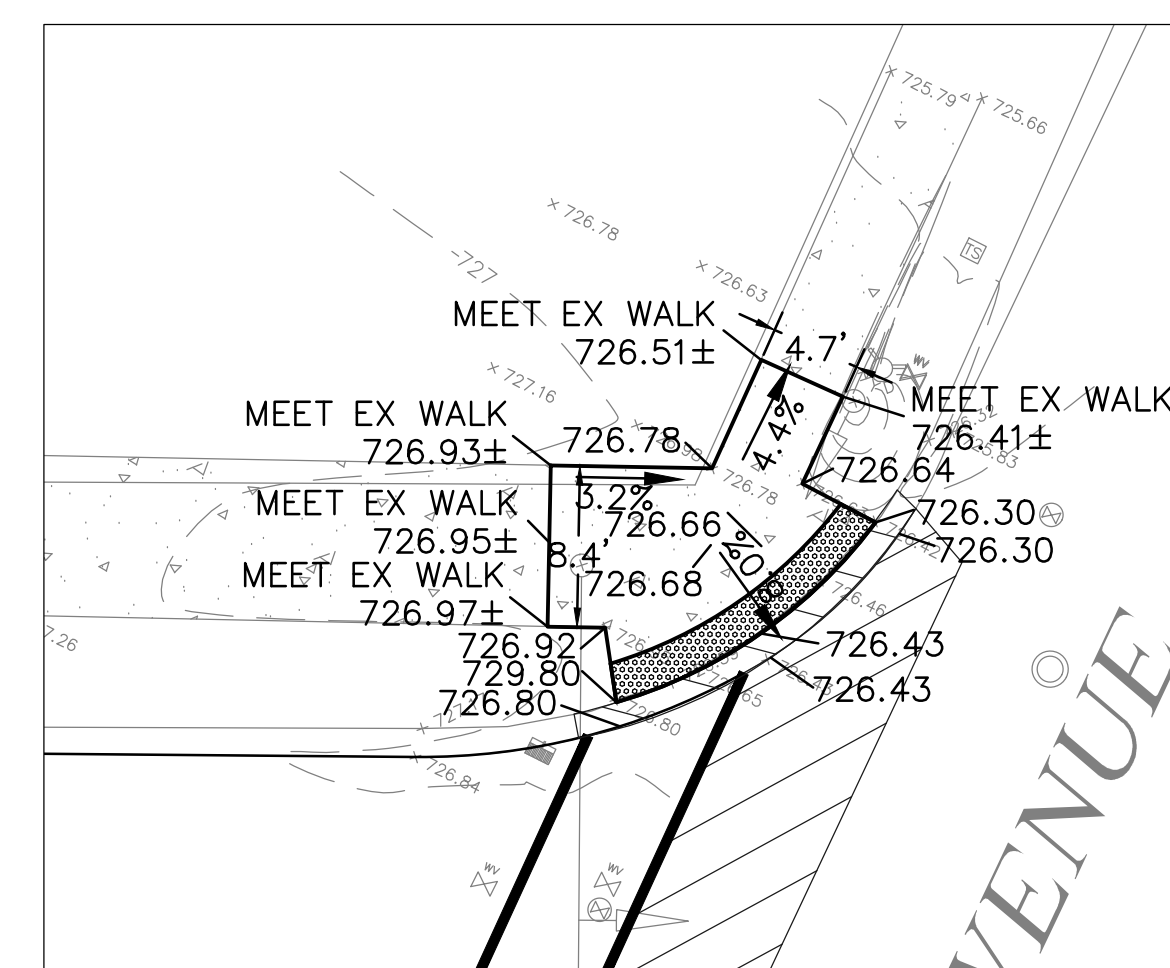

**SIDEWALK DETAIL S20
STA 74+60 - LEFT SIDE**

FILE NAME =	USER NAME -- USER	DESIGNED -- NRH	REVISED
FILE NAME =		DRAWN -- NRH	REVISED
	PLOT SCALE --	CHECKED -- JPT	REVISED
	PLOT DATE -- 03/30/18	DATE -- 03/30/18	REVISED

STATE OF ILLINOIS
DEPARTMENT OF TRANSPORTATION

MAPLE AVENUE IMPROVEMENTS
SIDEWALK DETAILS

SCALE: 1"=10' SHEET NO. 2 OF 2 SHEETS STA. TO STA.

F.A.U. RTE.	SECTION	COUNTY	TOTAL SHEETS	SHEET NO.
1487	18-00113-00-RS	DUPAGE	19	11
CONTRACT NO. 61E92				
FED. ROAD DIST. NO. 1	ILLINOIS	FED. AID PROJECT		

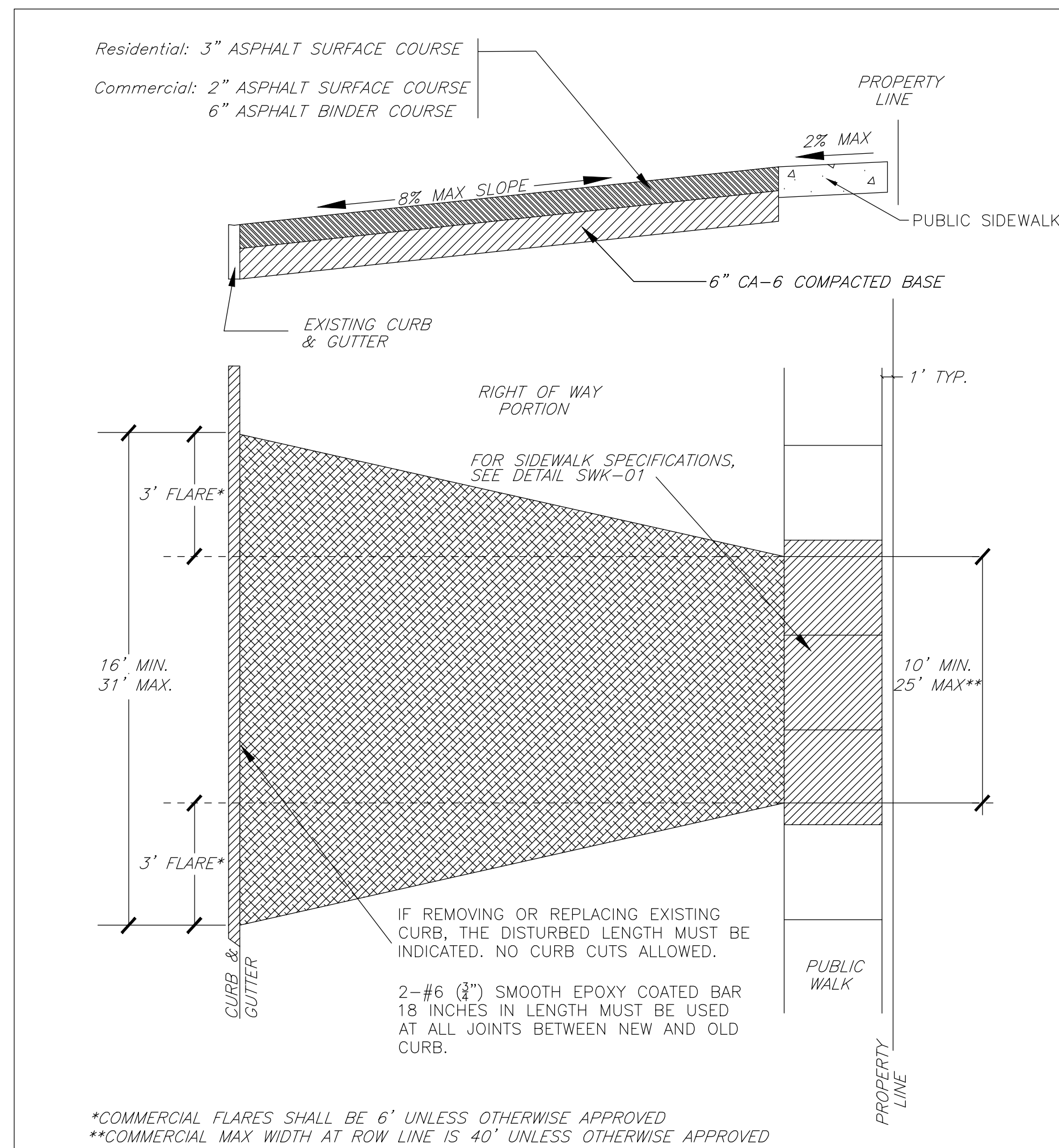

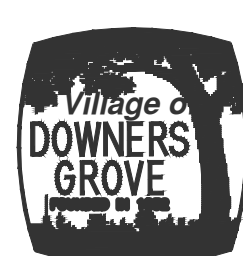
N.T.S.	DATE	REVISIONS	DRAWN BY	APPVD BY	STANDARD DETAIL
	03/25/11		S.A.V.	A.J.S.	 ASPHALT APPROACH WITH CURB
	05/21/14		S.A.V.	A.J.S.	
	03/01/15		A.J.S.	A.J.S.	
	01/01/17		N.R.H.	J.M.W.	
	01/01/18		N.R.H.	J.M.W.	
DRAWING NO. PVT-03					
I:\LIBRARY\DETAILS\PAVEMENT\PVT-03					

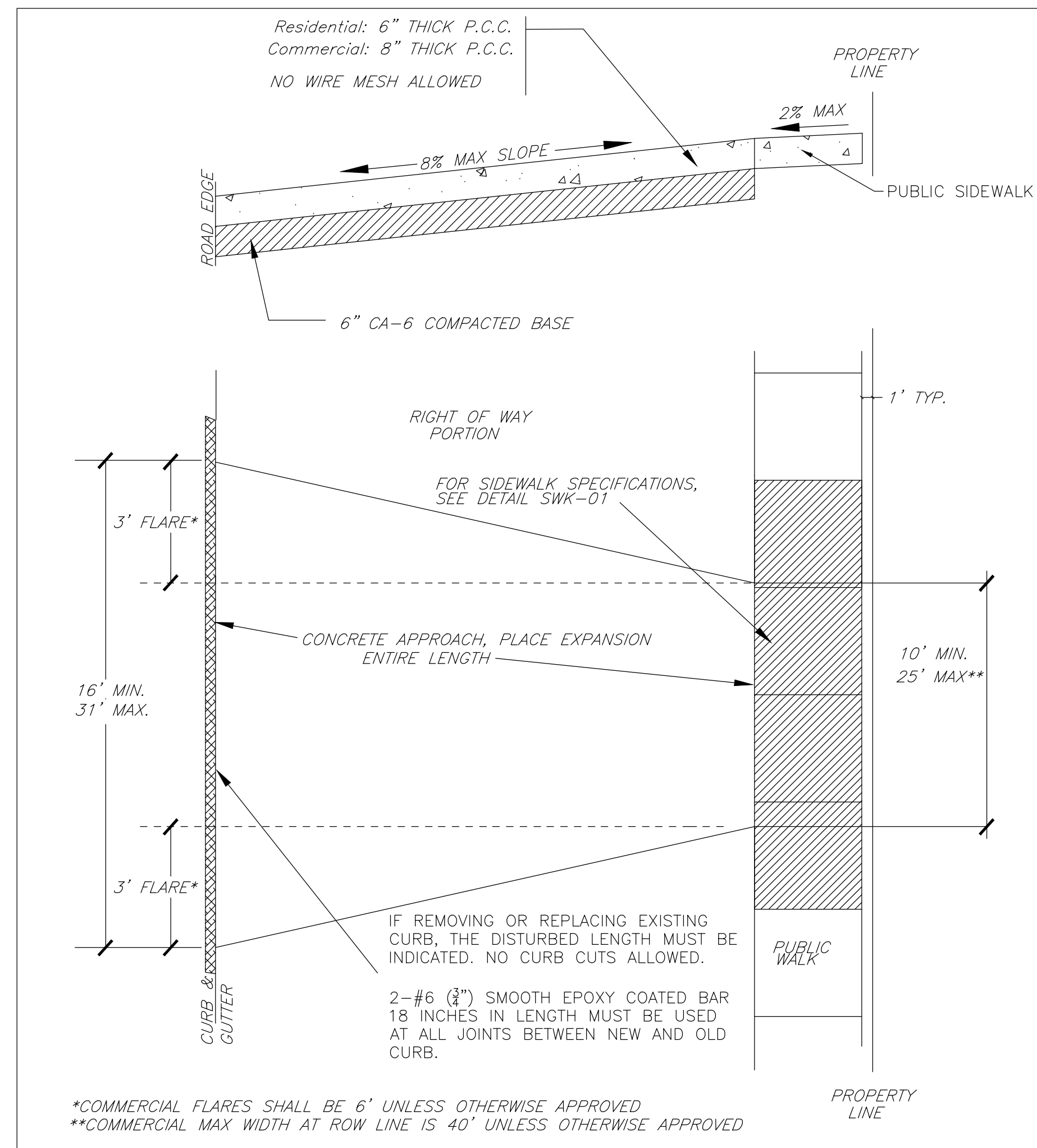

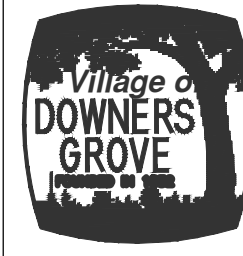
N.T.S.	DATE	REVISIONS	DRAWN BY	APPVD BY	STANDARD DETAIL
	02/20/07		J.M.L.	M.D.M.	 CONCRETE APPROACH WITH CURB
	03/25/11		S.A.V.	A.J.S.	
	03/01/15		A.J.S.	A.J.S.	
	01/01/17		N.R.H.	J.M.W.	
	01/01/18		N.R.H.	J.M.W.	
DRAWING NO. PVT-09					
I:\LIBRARY\DETAILS\PAVEMENT\PVT-09					

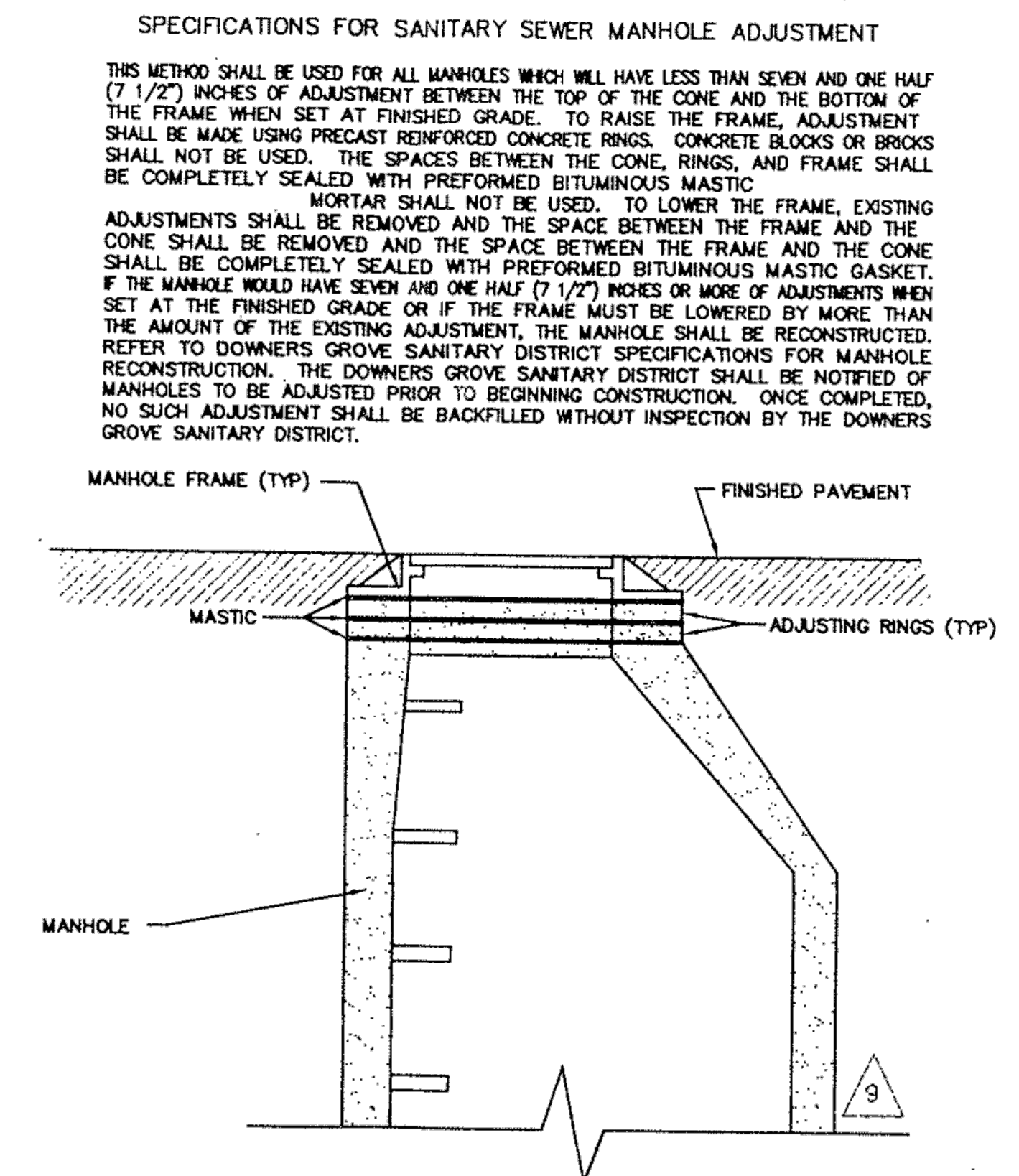

**DOWNERS GROVE SANITARY DISTRICT
DETAIL FOR SANITARY MANHOLE ADJUSTMENT**

FRAMES & LIDS TO
BE ADJUSTED
(SPECIAL)

FILE NAME =	USER NAME - USER	DESIGNED - NRH	REVISED
FILE NAME =		DRAWN - NRH	REVISED
	PLOT SCALE -	CHECKED - JPT	REVISED
	PLOT DATE - 03/30/18	DATE - 03/30/18	REVISED

STATE OF ILLINOIS
DEPARTMENT OF TRANSPORTATION

MAPLE AVENUE IMPROVEMENTS
VILLAGE DETAILS

F.A.U. RTE.	SECTION	COUNTY	TOTAL SHEETS	SHEET NO.
1487	18-00113-00-RS	DUPAGE	19	12
FED. ROAD DIST. NO. 1			ILLINOIS	FED. AID PROJECT

NOT TO SCALE SHEET NO. 1 OF 1 SHEETS STA. TO STA.

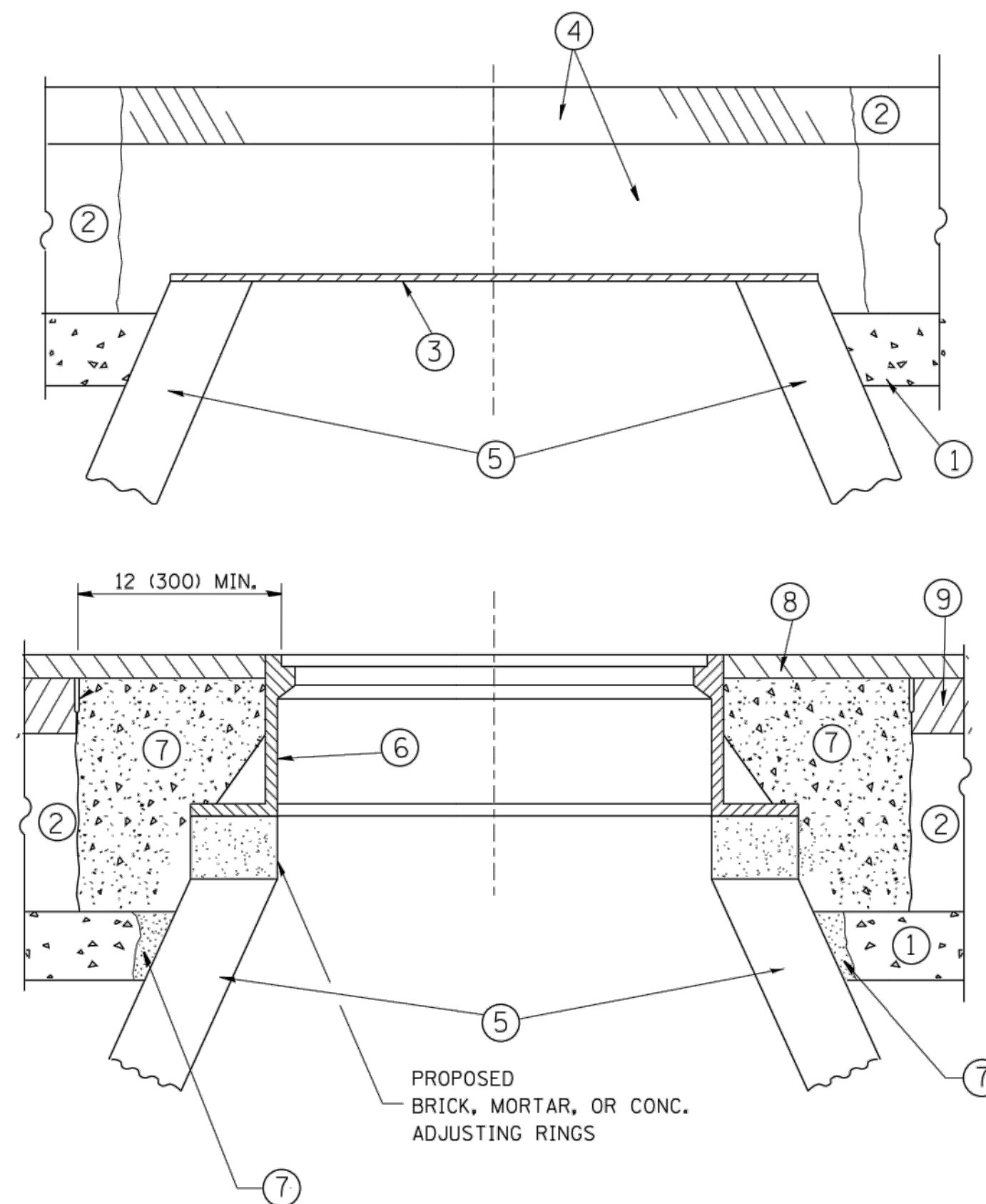

CONSTRUCTION PROCEDURES

STAGE 1 (BEFORE PAVEMENT MILLING)

- A) REMOVE A MINIMUM OF 12 (300) OF THE PAVEMENT FROM AROUND THE STRUCTURE.
- B) REMOVE THE EXISTING FRAME AND LID FROM THE STRUCTURE.
- C) COVER THE STRUCTURE OPENING WITH A 36 (900) DIAMETER METAL PLATE.
- D) BACKFILL WITH CRUSHED STONE AND A MINIMUM 1 1/2 (40) THICK HMA SURFACE MIX APPROVED BY THE ENGINEER.

STAGE 2 (AFTER PAVEMENT MILLING)

- A) REMOVE THE HMA SURFACE MIX AND CRUSHED STONE.
- B) INSTALL THE FRAME AND LID; ADJUST THE FRAME TO ITS FINAL SURFACE ELEVATION.
- C) THE SURROUNDING SPACE SHALL BE FILLED WITH CLASS PP-1* CONCRETE TO THE ELEVATION OF THE SURFACE OF THE EXISTING BASE COURSE OR THE BINDER COURSE.

* UNLESS OTHERWISE SPECIFIED IN THE PLANS.

THE PROCEDURE EXPLAINED ABOVE SHALL CONFORM TO THE APPLICABLE PORTIONS OF SECTIONS 353, 406, 602, AND 603 OF THE STANDARD SPECIFICATIONS EXCEPT THAT "THE CONTRACTOR SHALL ADJUST THE STRUCTURES TO THE FINISHED PAVEMENT ELEVATION NO MORE THAN 5 CALENDAR DAYS PRIOR TO PLACEMENT OF THE FINAL LIFT OF SURFACE UNLESS APPROVED BY THE ENGINEER."

LEGEND

- ① SUB-BASE GRANULAR MATERIAL
- ② EXISTING PAVEMENT
- ③ 36 (900) DIAMETER METAL PLATE
- ④ PROPOSED CRUSHED STONE AND HMA SURFACE MIX
- ⑤ EXISTING STRUCTURE
- ⑥ FRAME AND LID (SEE NOTES)
- ⑦ CLASS PP-1* CONCRETE
- ⑧ PROPOSED HMA SURFACE COURSE
- ⑨ PROPOSED HMA BINDER COURSE

LOCATION OF STRUCTURES:

THE CONTRACTOR WILL BE REQUIRED TO KEEP A RECORD OF THE LOCATIONS OF THE BURIED STRUCTURES ACCORDING TO THE STATION AND DISTANCE LEFT OR RIGHT OF THE CENTERLINE OF PAVEMENT. UPON COMPLETION OF THE WORK, THE CONTRACTOR WILL DELIVER THE RECORD TO THE ENGINEER.

BASIS OF PAYMENT:

REMOVING FRAMES AND LIDS ON DRAINAGE AND UTILITY STRUCTURES IN THE PAVEMENT PRIOR TO MILLING, AND ADJUSTING TO FINAL GRADE PRIOR TO PLACING THE SURFACE COURSE, WILL BE PAID FOR AT THE CONTRACT UNIT PRICE EACH FOR "FRAMES AND LIDS TO BE ADJUSTED (SPECIAL)."

THIS WORK WILL NOT BE PAID FOR WHEN DRAINAGE AND UTILITY STRUCTURES ARE SPECIFIED FOR PAYMENT AS STRUCTURE RECONSTRUCTION.

NEW FRAMES AND LIDS, WHEN SPECIFIED, WILL BE PAID FOR SEPARATELY.

NOTES:

EXISTING BROKEN FRAMES AND LIDS SHALL BE REMOVED AND DISPOSED OF BY THE CONTRACTOR AND SHALL BE REPLACED AS DIRECTED BY THE ENGINEER. REPLACEMENT FRAMES AND LIDS WILL BE PAID FOR IN ACCORDANCE WITH ARTICLE 109.04 OF THE STANDARD SPECIFICATIONS UNLESS A SEPARATE PAY ITEM HAS BEEN PROVIDED.

IF THE EXISTING LIDS ARE OPEN, THE FRAME WILL BE ADJUSTED TO THE ELEVATION OF THE MILLED PAVEMENT SURFACE PRIOR TO THE MILLING OPERATION. THE FRAME WILL NOT BE REMOVED AND COVERED BY THE METAL PLATE.

CITY OF CHICAGO CASTINGS ARE THE PROPERTY OF THE CITY AND THE CONTRACTOR SHALL NOTIFY THE CITY FOR REMOVAL AND DISPOSITION OF THE CASTINGS.

THE METAL PLATE USED TO COVER THE STRUCTURE SHALL REMAIN THE PROPERTY OF THE CONTRACTOR.

WHEN STRUCTURES ARE TO BE ADJUSTED OR RECONSTRUCTED, THE LOWERING AND RAISING OF THE FRAMES AND LIDS WILL NOT BE PAID FOR SEPARATELY BUT WILL BE INCLUDED IN THE COST OF THE CORRESPONDING PAY ITEM.

DETAILS FOR FRAMES AND LIDS ADJUSTMENT WITH MILLING

ALL DIMENSIONS ARE IN INCHES (MILLIMETERS) UNLESS OTHERWISE SHOWN

FILE NAME =	USER NAME = bauerdl	DESIGNED - R. SHAH	REVISED - R. WIEDEMAN 05-14-04
c:\pw\work\p\idot\bauerdl\0108315\bd08.dgn		DRAWN -	REVISED - R. BORO 01-01-07
	PLOT SCALE = 1/648.5000' / m	CHECKED -	REVISED - R. BORO 03-09-11
	PLOT DATE = 12/6/2011	DATE - 10-25-94	REVISED - R. BORO 12-06-11

**STATE OF ILLINOIS
DEPARTMENT OF TRANSPORTATION**

**DETAILS FOR
FRAMES AND LIDS ADJUSTMENT WITH MILLING**

SCALE: NONE SHEET NO. 1 OF 1 SHEETS STA. TO STA.

F.A.U. RTE.	SECTION	COUNTY	TOTAL SHEETS	SHEET NO.
1487	18-00113-00-RS	DUPAGE	19	13
BD600-03 (BD-8)		CONTRACT NO. 61E92		
FED. ROAD DIST. NO. 1 ILLINOIS FED. AID PROJECT				

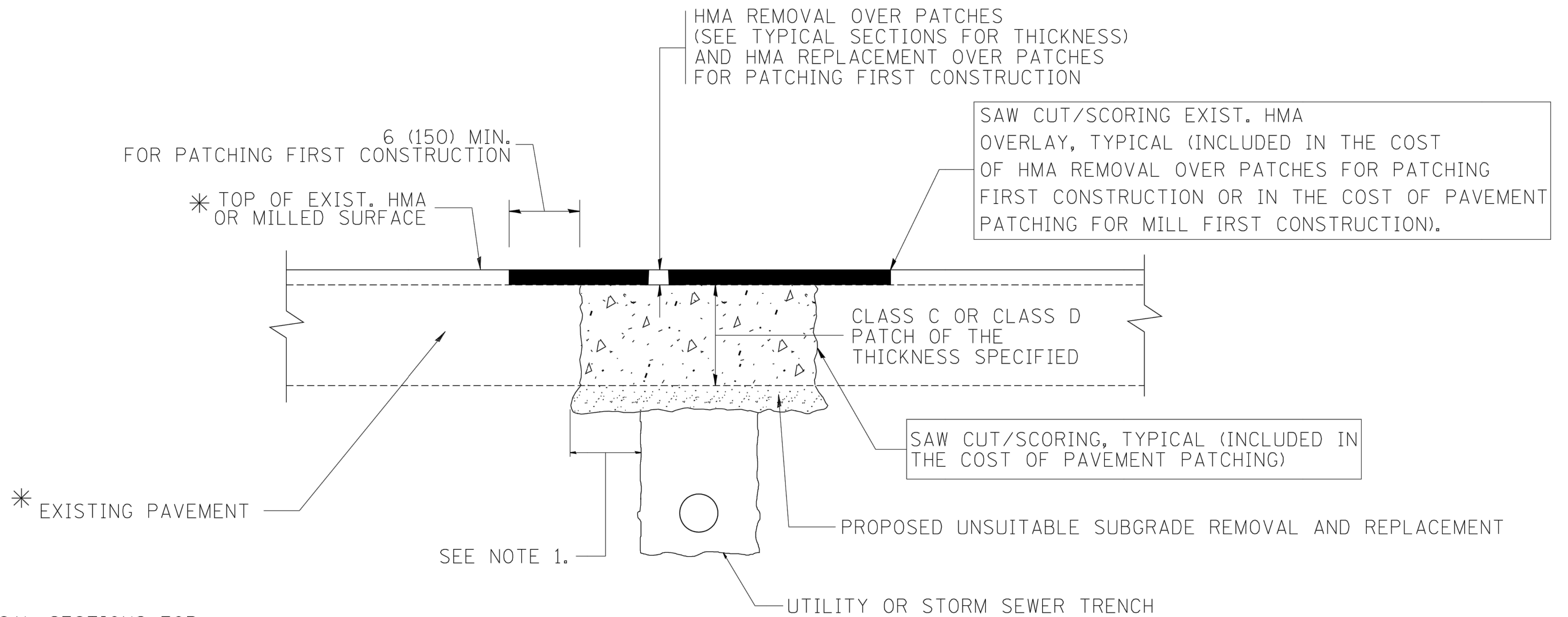

* SEE TYPICAL SECTIONS FOR
THICKNESS AND MATERIALS

NOTES:

1. THE WIDTH OF THE FULL DEPTH PATCH OVER A TRENCH SHALL BE 12 (300) WIDER ON EACH SIDE OF THE TRENCH.
2. FOR METHOD OF MEASUREMENT AND BASIS OF PAYMENT, SEE RECURRING SPECIAL PROVISION "PATCHING WITH HOT-MIX ASPHALT OVERLAY REMOVAL".

SEQUENCE OF CONSTRUCTION (PATCHING FIRST)

1. REMOVE THE EXISTING HMA MATERIAL OVER THE AREA TO BE PATCHED.
2. REMOVE AND REPLACE WITH CLASS C OR D PATCH.
3. REPLACE HMA MATERIAL OVER THE AREA TO BE PATCHED.

SEQUENCE OF CONSTRUCTION (MILLING FIRST)

1. MILL HMA FIRST IF THERE IS AT LEAST 4 1/2 INCHES OR MORE OF HMA MATERIAL ON TOP OF THE EXISTING PAVEMENT OR IF THE PAVEMENT IS FULL DEPTH HMA. A MINIMUM OF 2 INCHES OF HMA MATERIAL SHALL BE IN PLACE AFTER MILLING.
2. REMOVE AND REPLACE WITH FULL DEPTH CLASS D PATCHES TO TOP OF MILLED SURFACE.

ALL DIMENSIONS ARE IN INCHES (MILLIMETERS) UNLESS OTHERWISE SHOWN.

FILE NAME = c:\projects\diststd22x34\bd22.dgn	USER NAME = bouerd1	DESIGNED - R. SHAH	REVISED - A. ABBAS 04-27-98	STATE OF ILLINOIS DEPARTMENT OF TRANSPORTATION	PAVEMENT PATCHING FOR HMA SURFACED PAVEMENT			F.A.U. RTE.	SECTION	COUNTY	TOTAL SHEETS	SHEET NO.	
		DRAWN -	REVISED - R. BORO 01-01-07		SCALE: NONE	SHEET NO. 1 OF 1 SHEETS	STA.	TO STA.	1487	18-00113-00-RS	DUPAGE	19	14
		PLOT SCALE = 50.000' / IN.	CHECKED -		REVISED - R. BORO 09-04-07				BD400-04 (BD-22)		CONTRACT NO. 61E92		
		PLOT DATE = 10/27/2008	DATE - 10-25-94		REVISED - K. ENG 10-27-08				FED. ROAD DIST. NO. 1 ILLINOIS FED. AID PROJECT				

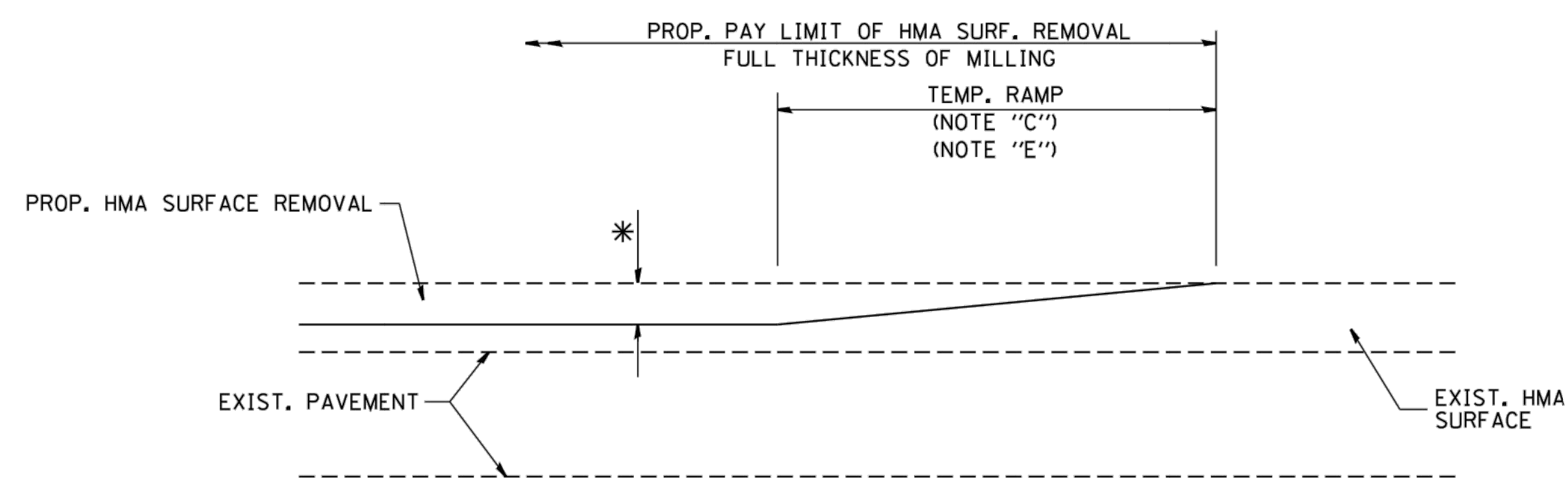

MILLED TEMPORARY RAMP
(FOR BUTT JOINT AND HMA TAPER SEE DETAIL BELOW)

OPTION 1

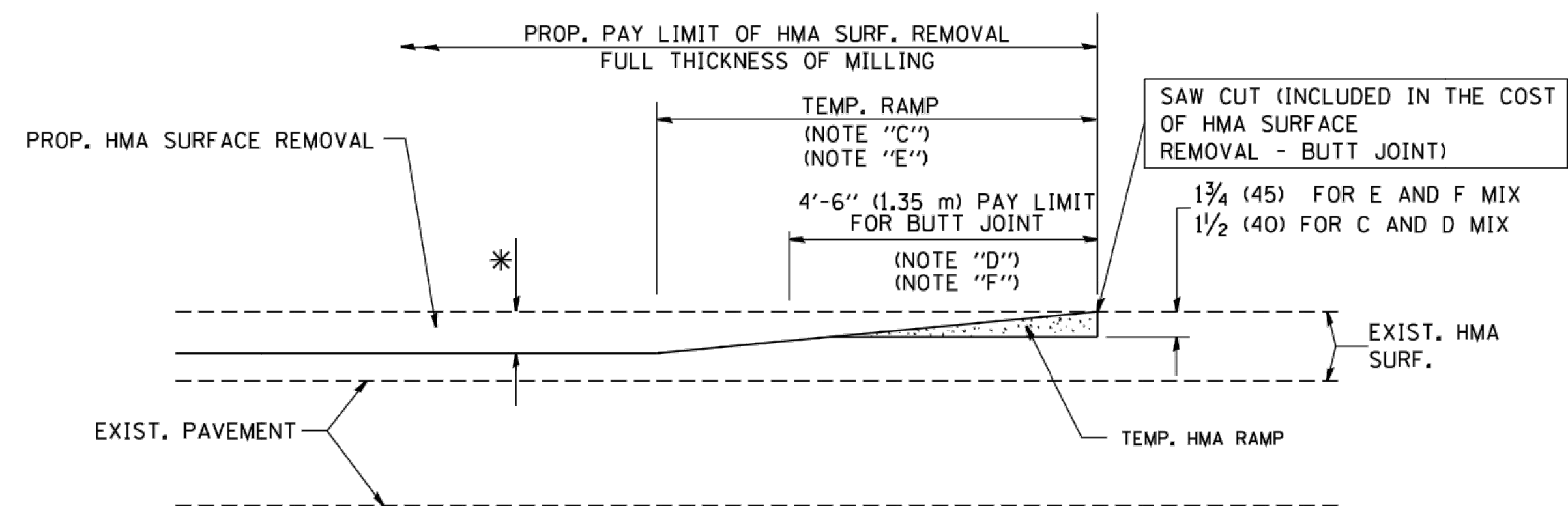

HMA CONSTRUCTED TEMPORARY RAMP
(FOR BUTT JOINT AND HMA TAPER SEE DETAIL BELOW)

OPTION 2

TYPICAL TEMPORARY RAMP

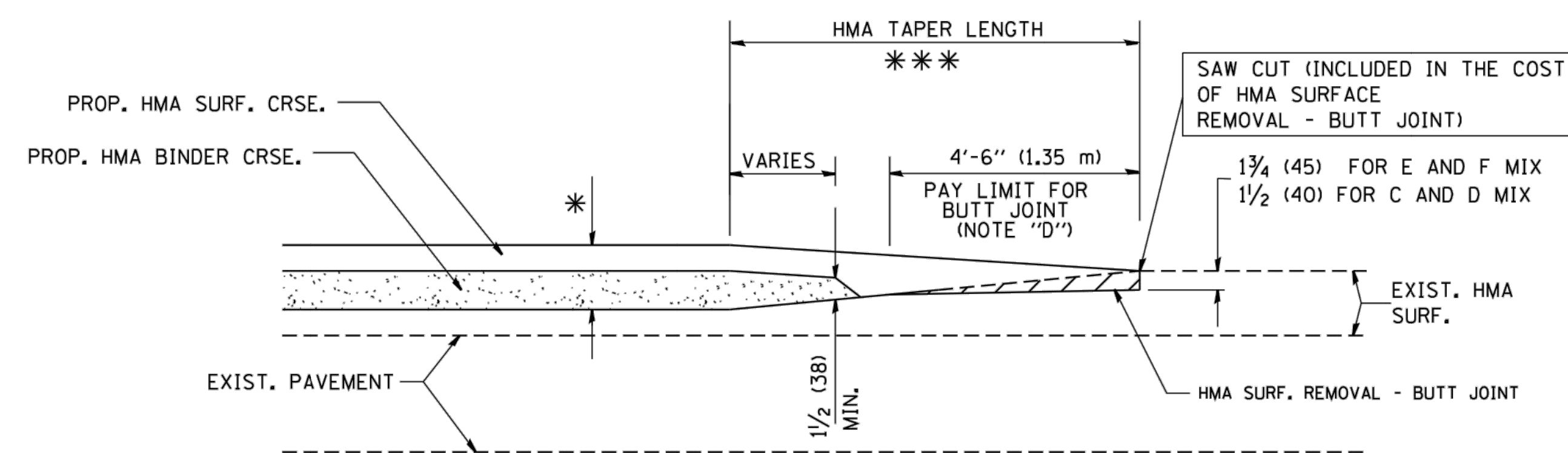

BUTT JOINT AND HMA TAPER

TYPICAL BUTT JOINT AND HMA TAPER
FOR MILLING AND RESURFACING

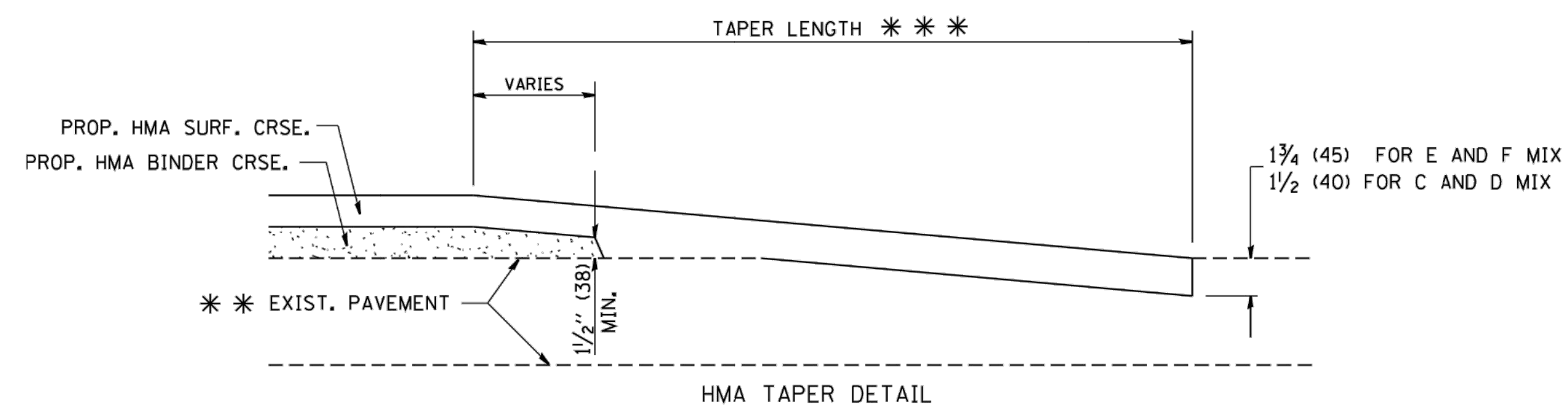
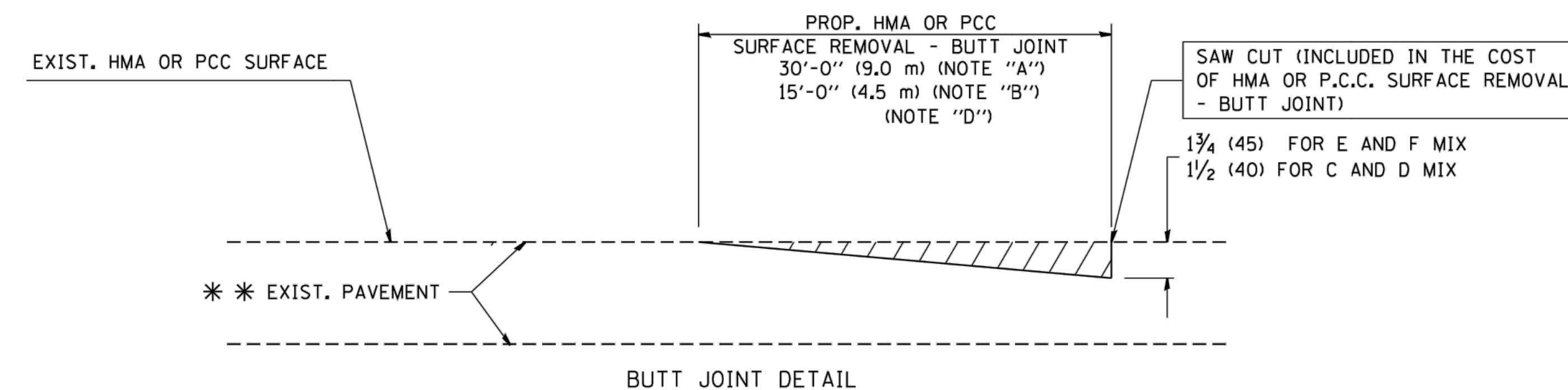

TYPICAL BUTT JOINT AND HMA TAPER
FOR RESURFACING ONLY

*** PC CONCRETE, HMA OR HMA RESURFACED PAVEMENT.

NOTES

- A: MAINLINE ROADWAYS AND MAJOR SIDE ROADS.
 - B: MINOR SIDE ROADS.
 - C: THE TEMP. RAMP SHALL BE CONSTRUCTED IMMEDIATELY UPON REMOVAL OF THE EXISTING HMA SURFACE.
 - D: THE BUTT JOINT SHALL BE CONSTRUCTED IMMEDIATELY PRIOR TO PLACING THE PROPOSED HMA COURSES.
 - E: TAPER THE TEMP. RAMP AT A RATE OF 3'-0" (900 mm) PER 1 INCH (25 mm) OF MILLING THICKNESS.
 - F: INSTALLATION AND REMOVAL OF THE 4'-6" (1.35 m) TEMP. RAMP IS INCLUDED IN COST OF HMA SURFACE REMOVAL - BUTT JOINT
 - G: SEE ARTICLE 406.08 AND 406.14 OF THE STANDARD SPECIFICATIONS FOR "HMA AND/OR PCC SURFACE REMOVAL, BUTT JOINT".
- * SEE TYPICAL SECTIONS FOR MILLING THICKNESS.
- *** 20'-0" (6.1 m) PER 1 (25) RESURFACING (NOTE "A")
10'-0" (3.0 m) PER 1 (25) RESURFACING (NOTE "B")

BASIS OF PAYMENT:

THE BUTT JOINT WILL BE PAID FOR AT THE CONTRACT UNIT PRICE PER SQUARE YARD (SQUARE METER) FOR "HOT-MIX ASPHALT SURFACE REMOVAL - BUTT JOINT" OR FOR "PORTLAND CEMENT CONCRETE SURFACE REMOVAL - BUTT JOINT".

ALL DIMENSIONS ARE IN INCHES (MILLIMETERS) UNLESS OTHERWISE SHOWN.

FILE NAME = W:\diststd\22x34\bd32.dgn	USER NAME = goglianobt	DESIGNED - M. DE YONG	REVISED - R. SHAH 10-25-94
		DRAWN -	REVISED - A. ABBAS 03-21-97
	PLOT SCALE = 58.0000' / IN.	CHECKED -	REVISED - M. GOMEZ 04-06-01
	PLOT DATE = 1/4/2008	DATE - 06-13-90	REVISED - R. BORO 01-01-07

STATE OF ILLINOIS
DEPARTMENT OF TRANSPORTATION

SCALE: NONE		SHEET NO. 1 OF 1 SHEETS		STA. TO STA.	
F.A.U. RTE.	SECTION	COUNTY	TOTAL SHEETS	SHEET NO.	
1487	18-00113-00-RS	DUPAGE	19	15	
BD400-05 BD32			CONTRACT NO. 61E92		
FED. ROAD DIST. NO. 1 ILLINOIS FED. AID PROJECT					

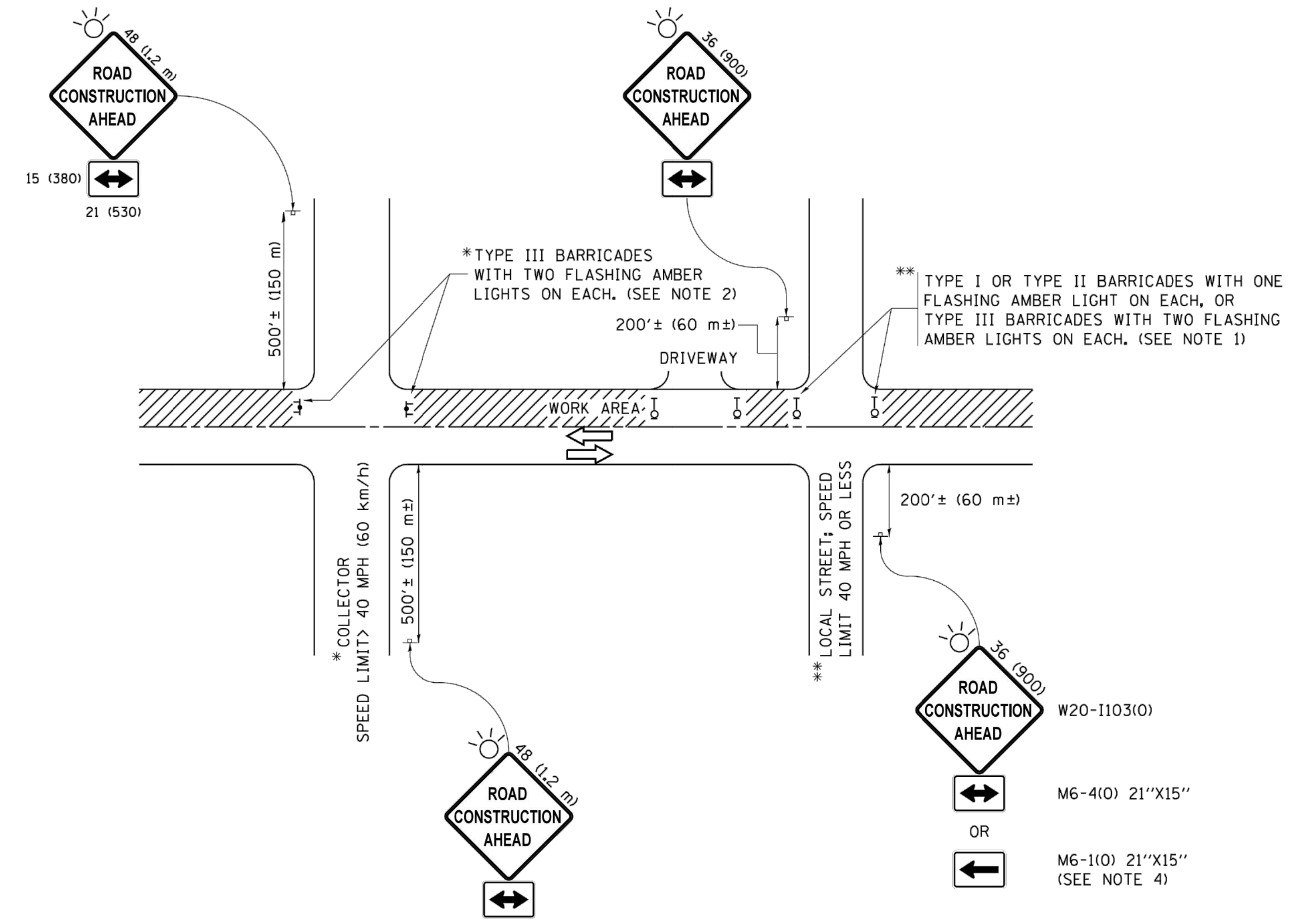

NOTES:

1. SIDE ROAD WITH A SPEED LIMIT OF 40 MPH (60 km/h) OR LESS AS SHOWN ON THE DRAWING AND AS DIRECTED BY THE ENGINEER:
 - a) ONE "ROAD CONSTRUCTION AHEAD" SIGN 36 x 36 (900x900) WITH A FLASHER MOUNTED ON IT APPROXIMATELY 200' (60 m) IN ADVANCE OF THE MAIN ROUTE.
 - b) THE CLOSED PORTION OF THE MAIN ROUTE SHALL BE PROTECTED BY BLOCKING WITH TYPE I, TYPE II OR TYPE III BARRICADES, 1/3 OF THE CROSS SECTION OF THE CLOSED PORTION.
2. SIDE ROAD WITH A SPEED LIMIT GREATER THAN 40 MPH (60 km/h) AS SHOWN ON THE DRAWING AND AS DIRECTED BY THE ENGINEER:
 - a) ONE "ROAD CONSTRUCTION AHEAD" SIGN 48 x 48 (1.2 m x 1.2 m) WITH A FLASHER MOUNTED ON IT APPROXIMATELY 500' (150 m) IN ADVANCE OF THE MAIN ROUTE.
 - b) THE CLOSED PORTION OF THE MAIN ROUTE SHALL BE PROTECTED BY BLOCKING WITH TYPE III BARRICADES, 1/2 OF THE CROSS SECTION OF THE CLOSED PORTION.
3. CONES MAY BE SUBSTITUTED FOR BARRICADES OR DRUMS AT HALF THE SPACING DURING DAY OPERATIONS. CONES SHALL BE A MINIMUM OF 28 (710) IN HEIGHT.
4. WHEN THE SIDE ROAD LIES BETWEEN THE BEGINNING OF THE MAINLINE SIGNING AND THE WORK ZONE, A SINGLE HEADED ARROW (M6-1) SHALL BE USED IN LIEU OF THE DOUBLE HEADED ARROW (M6-4).
5. WHEN WORK IS BEING PERFORMED ON A SIDE ROAD OR DRIVEWAY, FOLLOW THE APPLICABLE STANDARD(S). THE DIRECTIONAL ARROW (M6-1 OR M6-4) SHALL BE COVERED OR REMOVED WHEN NO LONGER CONSISTENT WITH THE TRAFFIC CONTROL SET-UP.
6. ADVANCE WARNING SIGNS ARE TO BE OMITTED ON DRIVEWAYS UNLESS OTHERWISE SPECIFIED IN THE PLANS OR BY THE ENGINEER.
7. THE TRAFFIC CONTROL AND PROTECTION FOR SIDE ROADS, INTERSECTIONS, AND DRIVEWAYS SHALL BE INCLUDED IN THE COST OF SPECIFIED TRAFFIC CONTROL STANDARDS OR ITEMS.

All dimensions are in inches (millimeters) unless otherwise shown.

FILE NAME =	USER NAME = footemj	DESIGNED - L.H.A.	REVISED - A. HOUSEH 10-15-96
p:\1\084EBIDINTEG\Illinois.gov\PWIDOT\Documents\IDOT Offices\District 1\Projects\Dist		DRAWN - CADDeta\CADsheets\tc1.dgn	REVISED - T. RAMMACHER 01-06-00
Default	PLOT SCALE = 50.000 ' / in.	CHECKED -	REVISED - A. SCHUETZE 07-01-13
	PLOT DATE = 9/15/2016	DATE - 06-89	REVISED - A. SCHUETZE 09-15-16

**STATE OF ILLINOIS
DEPARTMENT OF TRANSPORTATION**

**TRAFFIC CONTROL AND PROTECTION FOR
SIDE ROADS, INTERSECTIONS, AND DRIVEWAYS**

SCALE: NONE SHEET 1 OF 1 SHEETS STA. TO STA.

F.A.J. RTE.	SECTION	COUNTY	TOTAL SHEETS	SHEET NO.
1487	18-00113-00-RS	DUPAGE	19	16
TC-10			CONTRACT NO. 61E92	
ILLINOIS FED. AID PROJECT				

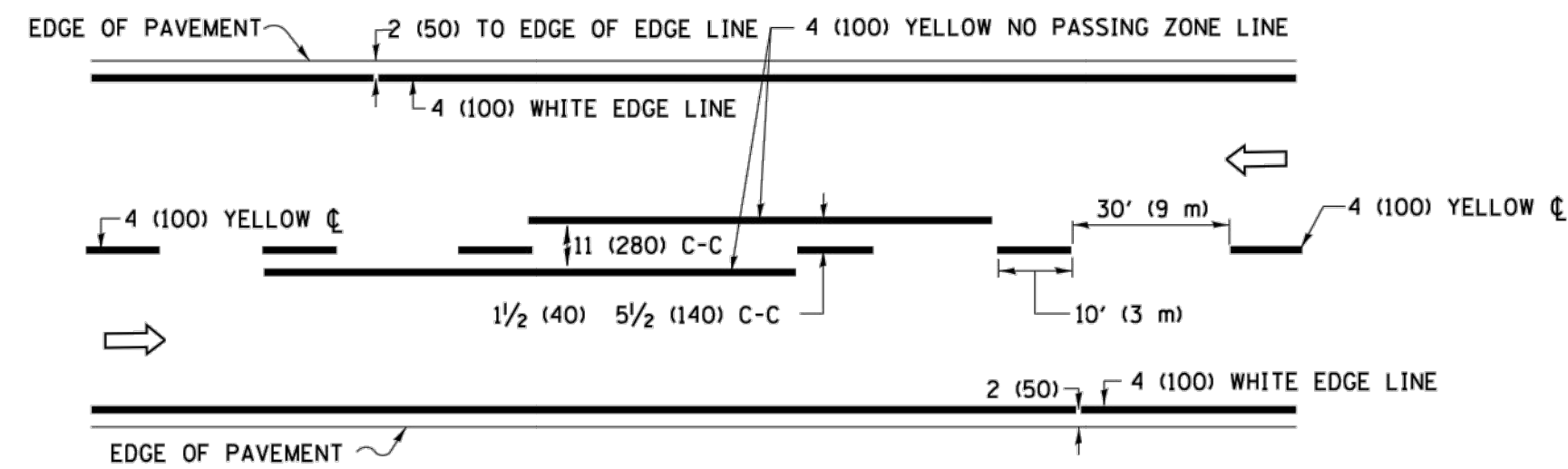

2-LANE ROADWAY

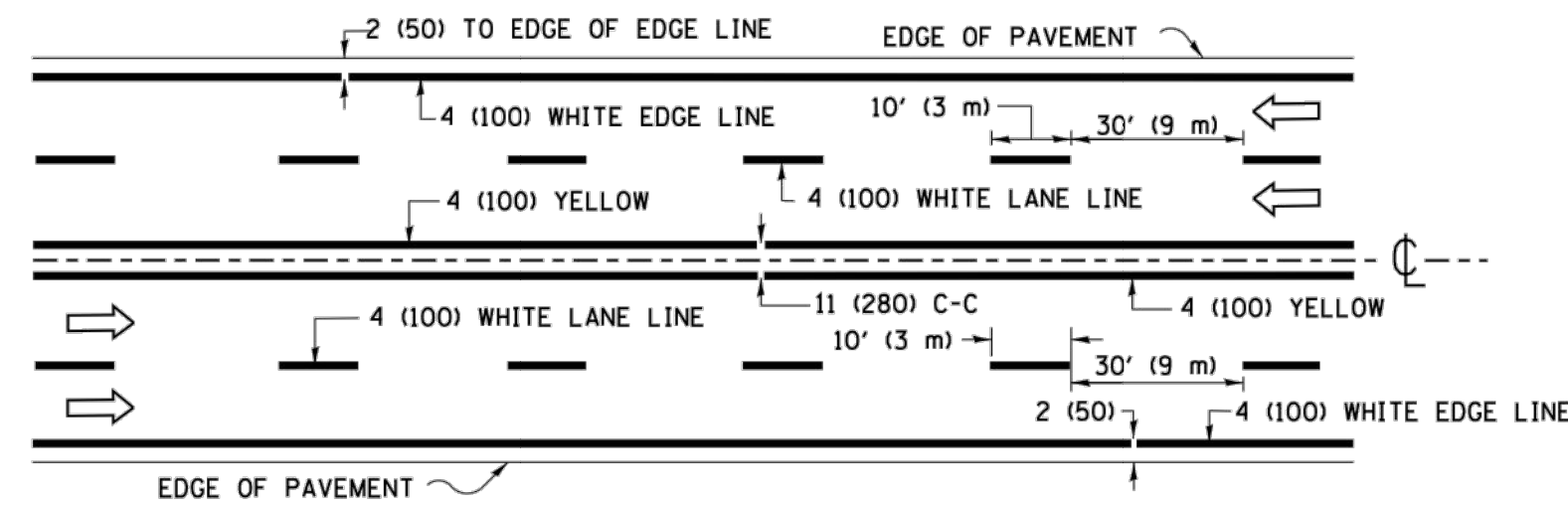

MULTI-LANE UNDIVIDED

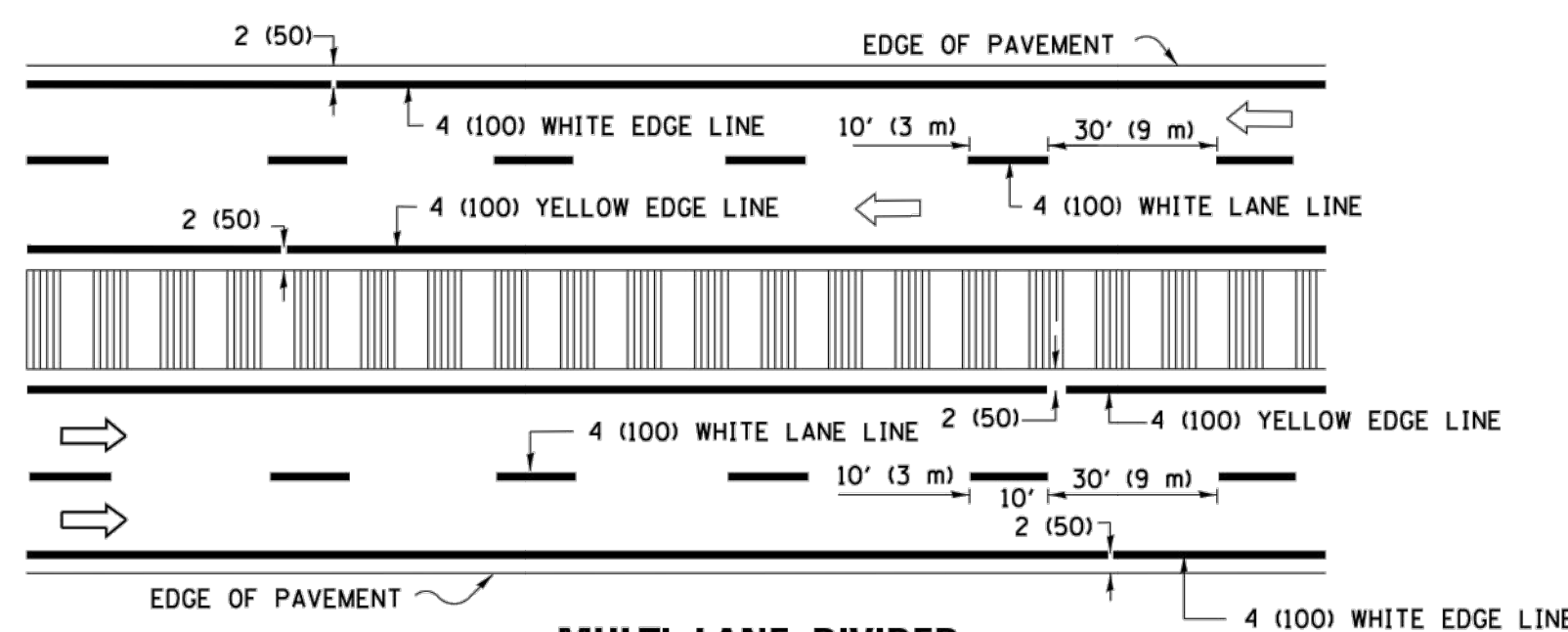

MULTI-LANE DIVIDED WITH MEDIAN

TYPICAL LANE AND EDGE LINE MARKING

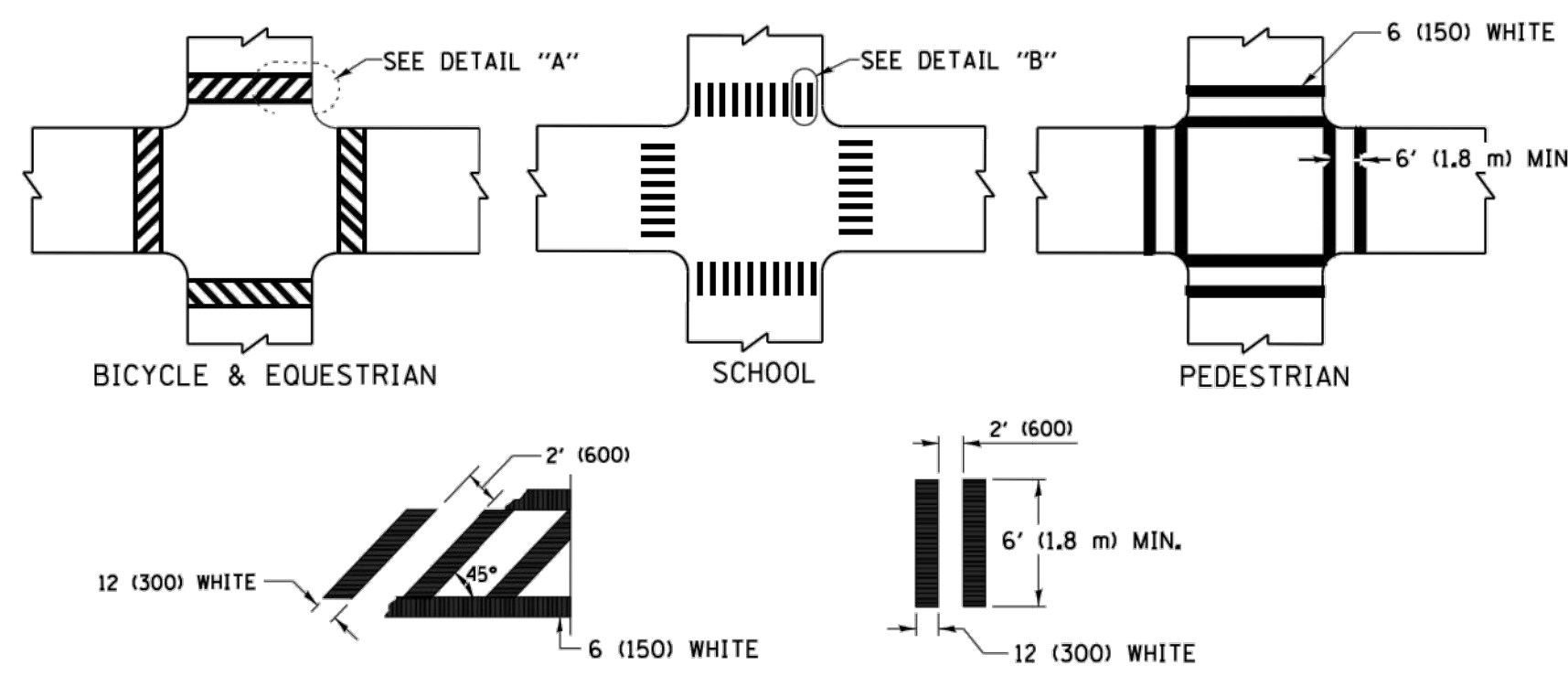

DETAIL "A"

DETAIL "B"

TYPICAL CROSSWALK MARKING

* MARKINGS SHALL BE INSTALLED PARALLEL TO THE CENTERLINE OF THE ROAD WHICH IT CROSSES

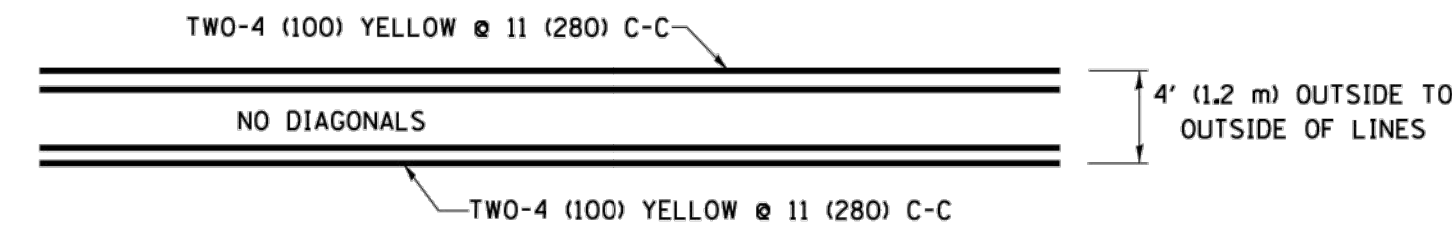

4' (1.2 m) WIDE MEDIANS ONLY

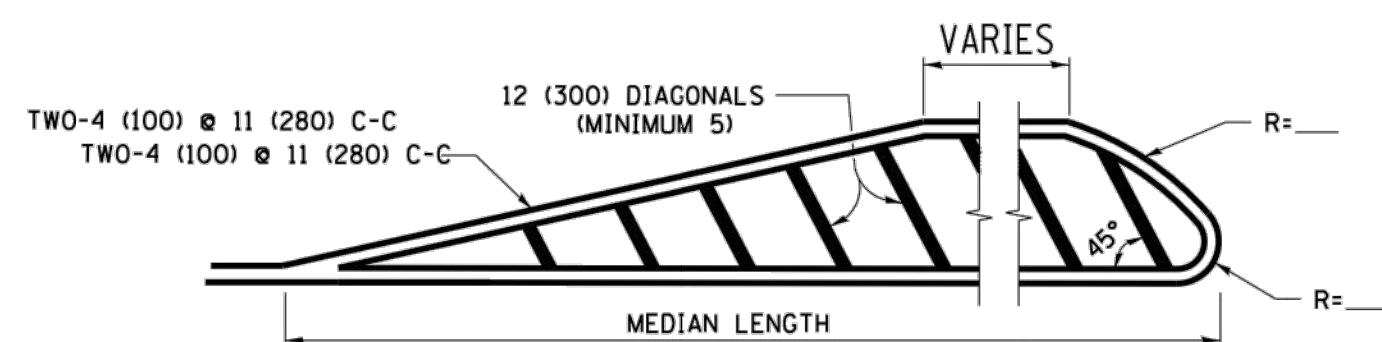

FOR MEDIAN LENGTHS WHERE DIAGONAL SPACING CANNOT BE ATTAINED, USE 5 (FIVE) EQUALLY SPACED DIAGONAL LINES.

DIAGONAL LINE SPACING: 50' (15 m) C-C (LESS THAN 30MPH (50 km/h))
75' (22.5 m) C-C 30MPH (50 km/h) TO 45MPH (70 km/h)
150' (45 m) C-C (MORE THAN 45MPH (70 km/h))

MEDIANS OVER 4' (1.2 m) WIDE

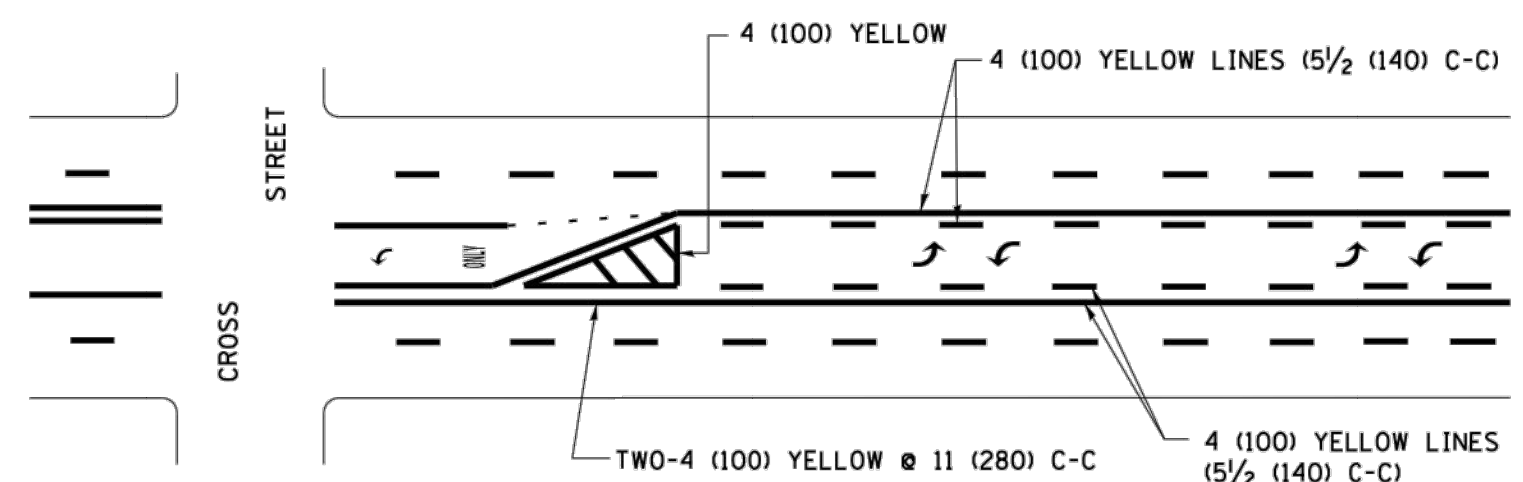

MEDIAN WITH TWO-WAY LEFT TURN LANE

TYPICAL PAINTED MEDIAN MARKING

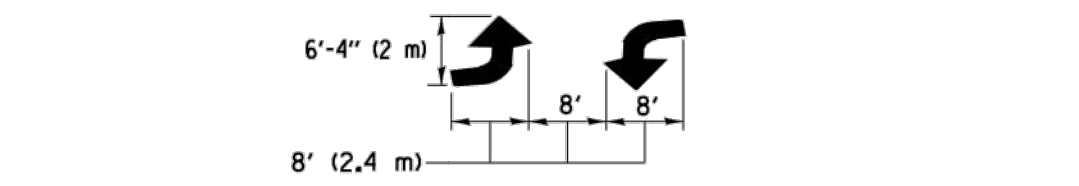

TYPICAL LEFT (OR RIGHT) TURN LANE

TYPICAL TURN LANE MARKING

FULL SIZE LETTERS 8' (2.4 m) AND ARROWS SHALL BE USED.
AREA = 15.6 SQ. FT. (1.5 m²) ONLY AREA = 20.8 SQ. FT. (1.9 m²)
* TURN LANES IN EXCESS OF 400' (120 m) IN LENGTH MAY HAVE AN ADDITIONAL SET OF ARROW - "ONLY" INSTALLED MIDWAY BETWEEN THE OTHER TWO SETS OF ARROW - "ONLY".

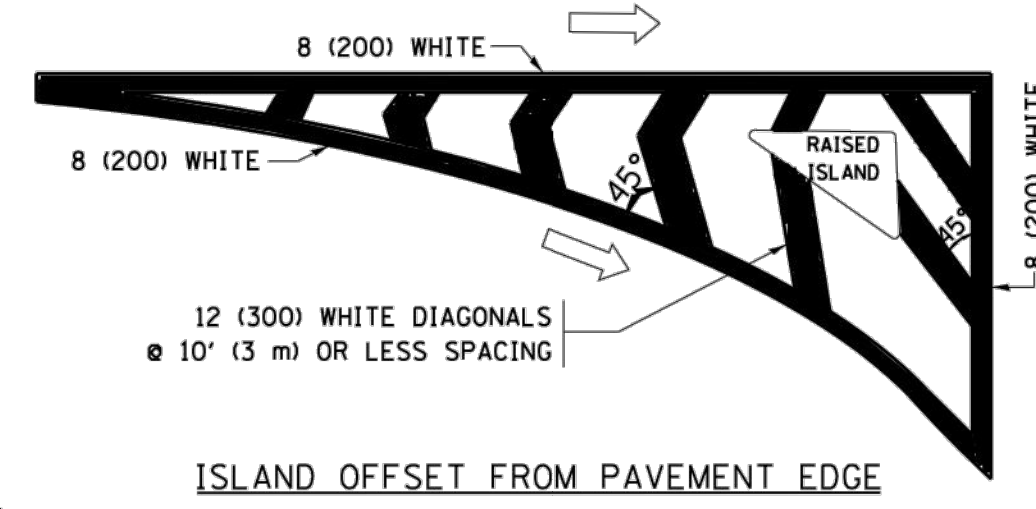

ISLAND OFFSET FROM PAVEMENT EDGE

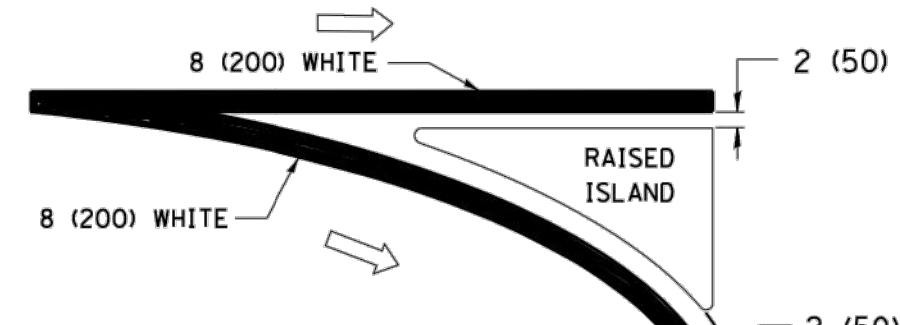

ISLAND AT PAVEMENT EDGE

TYPICAL ISLAND MARKING

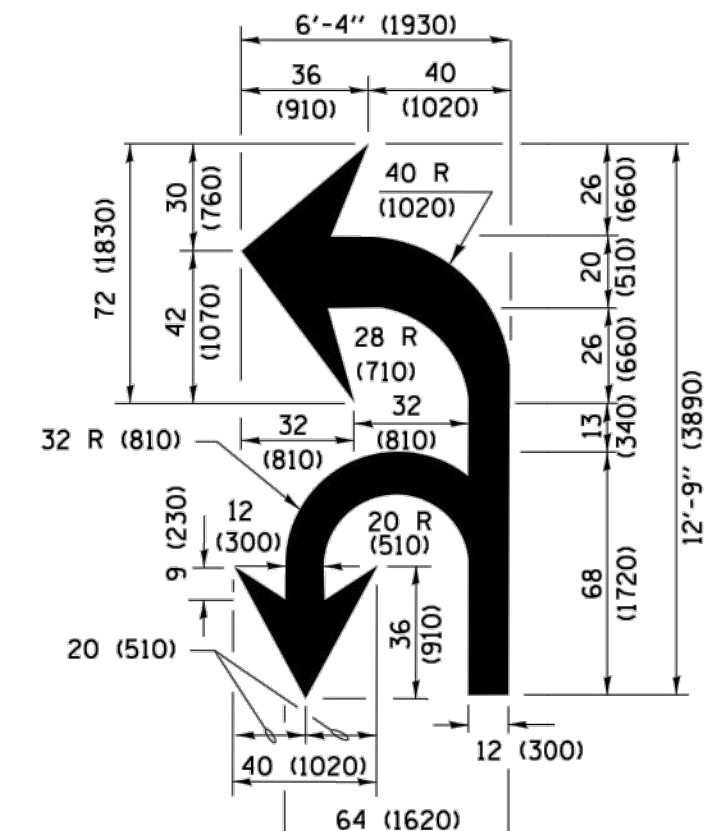

COMBINATION LEFT AND U-TURN

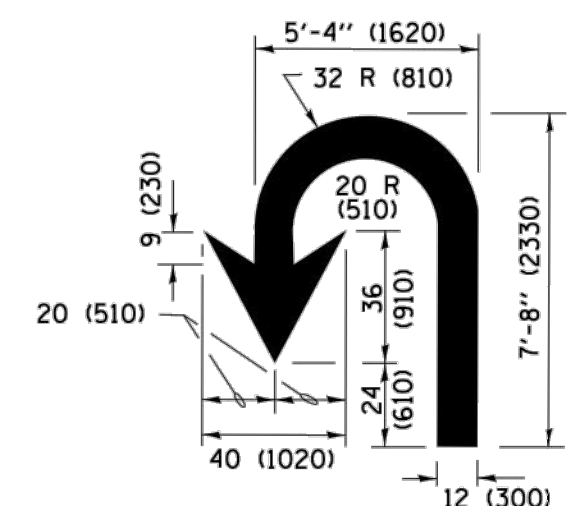

U-TURN

D(FT)	SPEED LIMIT
345	30
425	35
500	40
580	45
665	50
750	55

LANE REDUCTION TRANSITION

* LANE REDUCTION ARROWS REQUIRED AT SPEEDS OF 45 MPH OR GREATER OR WHEN SPECIFIED IN PLANS.

TYPE OF MARKING	WIDTH OF LINE	PATTERN	COLOR	SPACING /REMARKS
CENTERLINE ON 2 LANE PAVEMENT	4 (100)	SKIP-DASH	YELLOW	10' (3 m) LINE WITH 30' (9 m) SPACE
CENTERLINE ON MULTI-LANE UNDIVIDED PAVEMENT	2 @ 4 (100)	SOLID	YELLOW	11 (280) C-C
NO PASSING ZONE LINES: FOR ONE DIRECTION FOR BOTH DIRECTIONS	4 (100) 2 @ 4 (100)	SOLID SOLID	YELLOW YELLOW	5 1/2 (140) C-C FROM SKIP-DASH CENTERLINE 11 (280) C-C OMIT SKIP-DASH CENTERLINE BETWEEN
LANE LINES	4 (100) 5 (125) ON FREEWAYS	SKIP-DASH SKIP-DASH	WHITE WHITE	10' (3 m) LINE WITH 30' (9 m) SPACE
DOTTED LINES (EXTENSIONS OF CENTER, LANE OR TURN LANE MARKINGS)	SAME AS LINE BEING EXTENDED	SKIP-DASH	SAME AS LINE BEING EXTENDED	2' (600) LINE WITH 6' (1.8 m) SPACE
EDGE LINES	4 (100)	SOLID	YELLOW-LEFT WHITE-RIGHT	OUTLINE MEDIANS IN YELLOW
TURN LANE MARKINGS	6 (150) LINE; FULL SIZE LETTERS & SYMBOLS (8' (2.4m))	SOLID	WHITE	SEE TYPICAL TURN LANE MARKING DETAIL
TWO WAY LEFT TURN MARKING	2 @ 4 (100) EACH DIRECTION 8' (2.4m) LEFT ARROW	SKIP-DASH AND SOLID IN PAIRS	YELLOW WHITE	10' (3 m) LINE WITH 30' (9 m) SPACE FOR SKIP-DASH; 5 1/2 (140) C-C BETWEEN SOLID LINE AND SKIP-DASH LINE SEE TYPICAL TWO-WAY LEFT TURN MARKING DETAIL
CROSSWALK LINES (PEDESTRIAN) A. DIAGONALS (BIKE & EQUESTRIAN) B. LONGITUDINAL BARS (SCHOOL)	2 @ 6 (150) 12 (300) @ 45° 12 (300) @ 90°	SOLID SOLID SOLID	WHITE WHITE WHITE	NOT LESS THAN 6' (1.8 m) APART 2' (600) APART 2' (600) APART SEE TYPICAL CROSSWALK MARKING DETAILS.
STOP LINES	24 (600)	SOLID	WHITE	PLACE 4' (1.2 m) IN ADVANCE OF AND PARALLEL TO CROSSWALK, IF PRESENT. OTHERWISE, PLACE AT DESIRED STOPPING POINT, PARALLEL TO CROSSROAD CENTERLINE, WHERE POSSIBLE
PAINTED MEDIANS	2 @ 4 (100) WITH 12 (300) DIAGONALS @ 45° NO DIAGONALS USED FOR 4' (1.2 m) WIDE MEDIANS	SOLID	YELLOW; TWO WAY TRAFFIC WHITE; ONE WAY TRAFFIC	11 (280) C-C FOR THE DOUBLE LINE. SEE TYPICAL PAINTED MEDIAN MARKING.
GORE MARKING AND CHANNELIZING LINES	8 (200) WITH 12 (300) DIAGONALS @ 45°	SOLID	WHITE	DIAGONALS: 15' (4.5 m) C-C (LESS THAN 30MPH (50 km/h)) 20' (6 m) C-C 30MPH (50 km/h) TO 45MPH (70 km/h) 30' (9 m) C-C (OVER 45MPH (70 km/h))
RAILROAD CROSSING	24 (600) TRANSVERSE LINES; "RR" IS 6' (1.8 m) LETTERS; 16 (400) LINE FOR "X"	SOLID	WHITE	SEE STATE STANDARD 780001 AREA OF: "R"=3.6 SQ. FT. (0.33 m ²) EACH "X"=54.0 SQ. FT. (5.0 m ²)
SHOULDER DIAGONALS (REQUIRED FOR SHOULDERS ≥ 8')	12 (300) @ 45°	SOLID	WHITE - RIGHT YELLOW - LEFT	50' (15 m) C-C (LESS THAN 30MPH (50 km/h)) 75' (22.5 m) C-C (30 MPH (50 km/h) TO 45MPH (70 km/h)) 150' (45 m) C-C (OVER 45MPH (70 km/h))
U TURN ARROW	SEE DETAIL	SOLID	WHITE	16.3 SF
2 ARROW COMBINATION LEFT AND U TURN	SEE DETAIL	SOLID	WHITE	30.4 SF

FOR FURTHER DETAILS ON PAVEMENT MARKING REFER TO STANDARD SPECIFICATIONS FOR ROAD AND BRIDGE CONSTRUCTION AND STATE STANDARD 780001.

All dimensions are in inches (millimeters) unless otherwise shown.

FILE NAME = W:\distad\22x34\to13.dgn	USER NAME = jeyso	DESIGNED - EVERS	REVISED - C. JUCIUS 09-09-09
		DRAWN -	REVISED - C. JUCIUS 07-01-13
	PLOT SCALE = 50.000' / 1" =	CHECKED -	REVISED - C. JUCIUS 12-21-15
Default	PLOT DATE = 6/23/2017	DATE - 03-19-90	REVISED - C. JUCIUS 04-12-16

STATE OF ILLINOIS DEPARTMENT OF TRANSPORTATION

DISTRICT ONE TYPICAL PAVEMENT MARKINGS

F.A.U. RTE.	SECTION	COUNTY	TOTAL SHEETS	SHEET NO.
1487	18-00113-00-RS	DUPAGE	19	17
TC-13		CONTRACT NO.	61E92	
ILLINOIS FED. AID PROJECT				

SCALE: NONE SHEET 1 OF 1 SHEETS STA. TO STA.

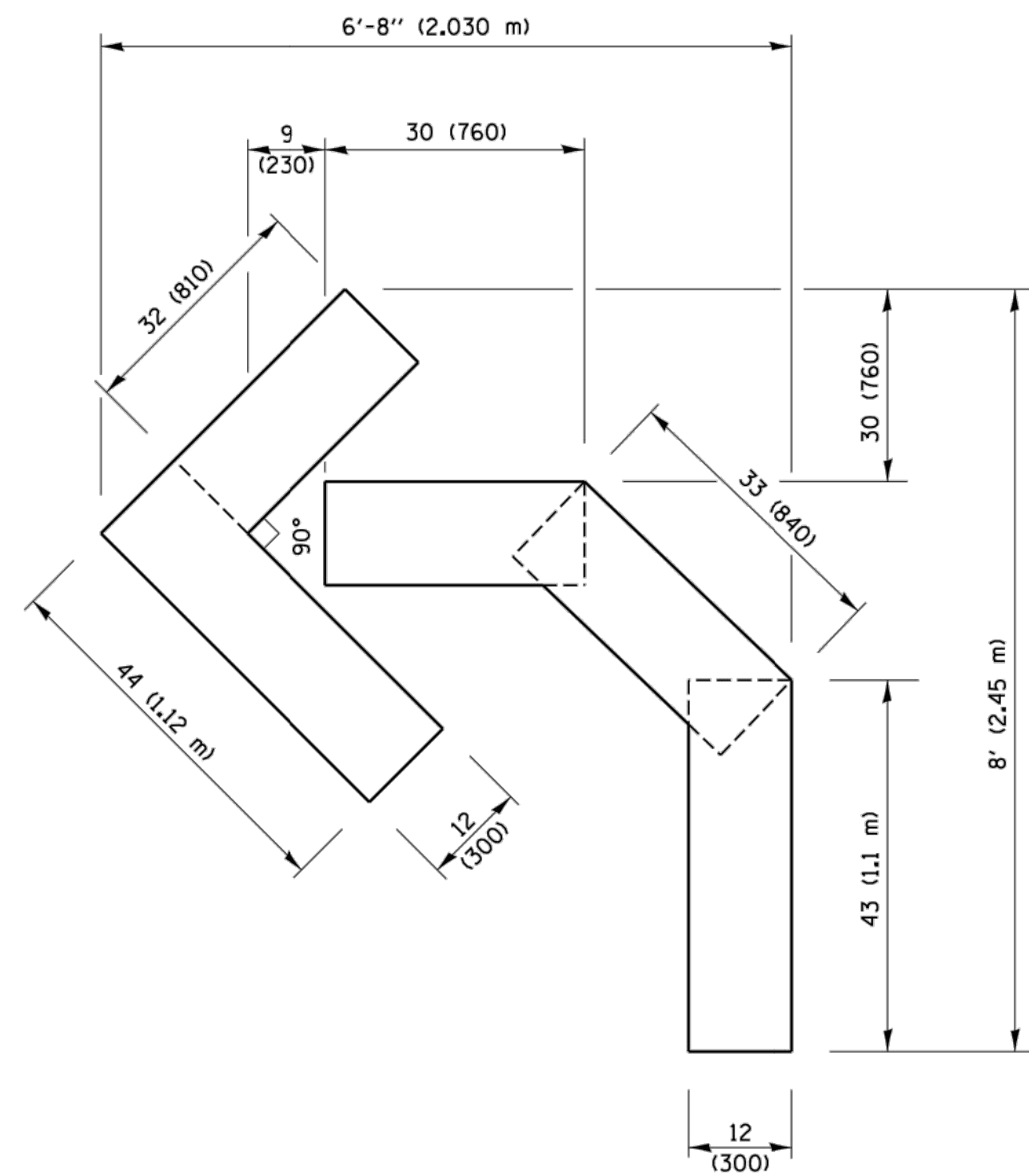

QUANTITY
 4 (100) LINE = 45.5 ft. (13.9 m)
 15.2 sq. ft. (1.41 sq. m)

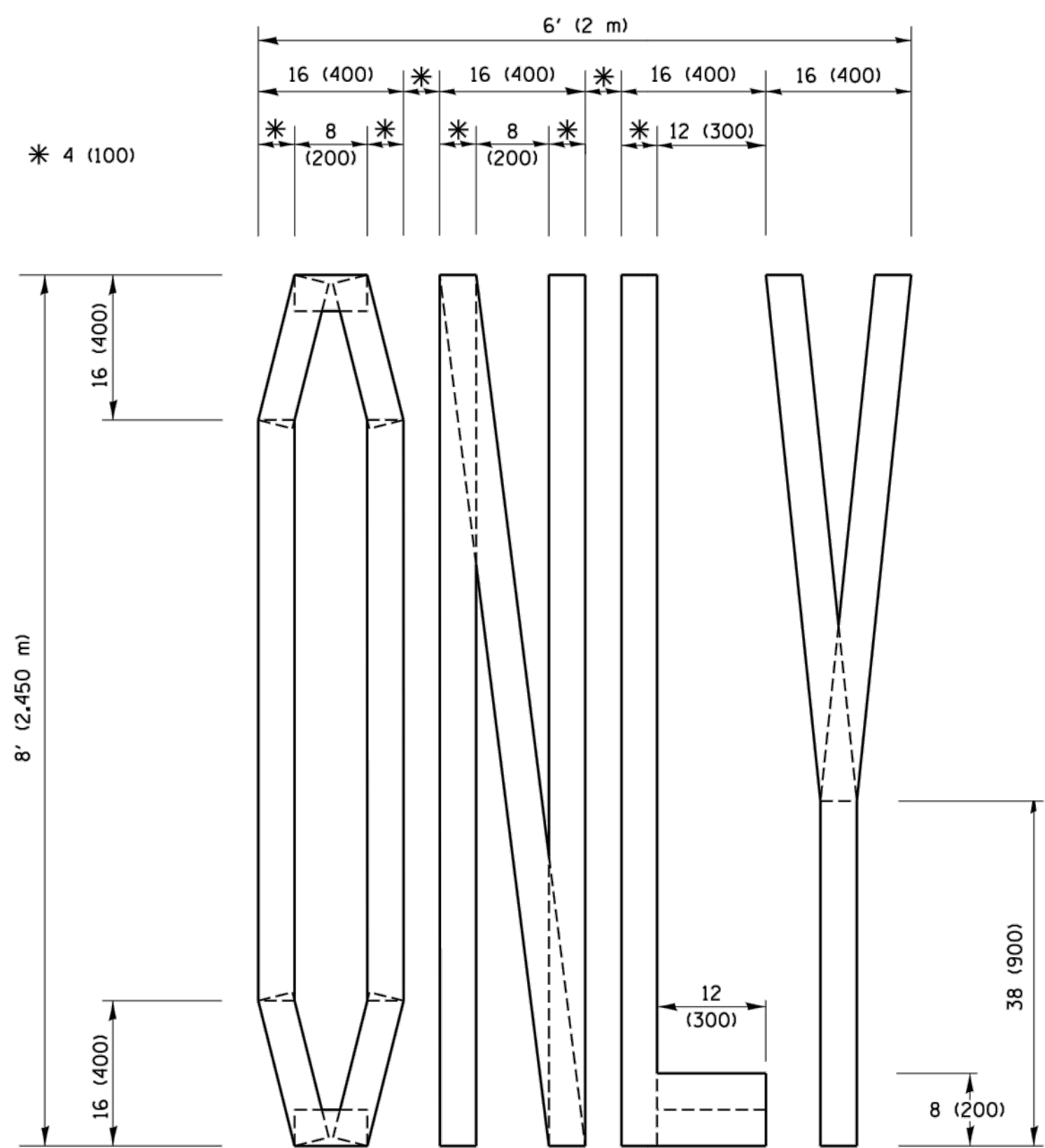

QUANTITY
 4 (100) LINE = 64.1 ft. (19.5 m)
 21.4 sq. ft. (1.99 sq. m)

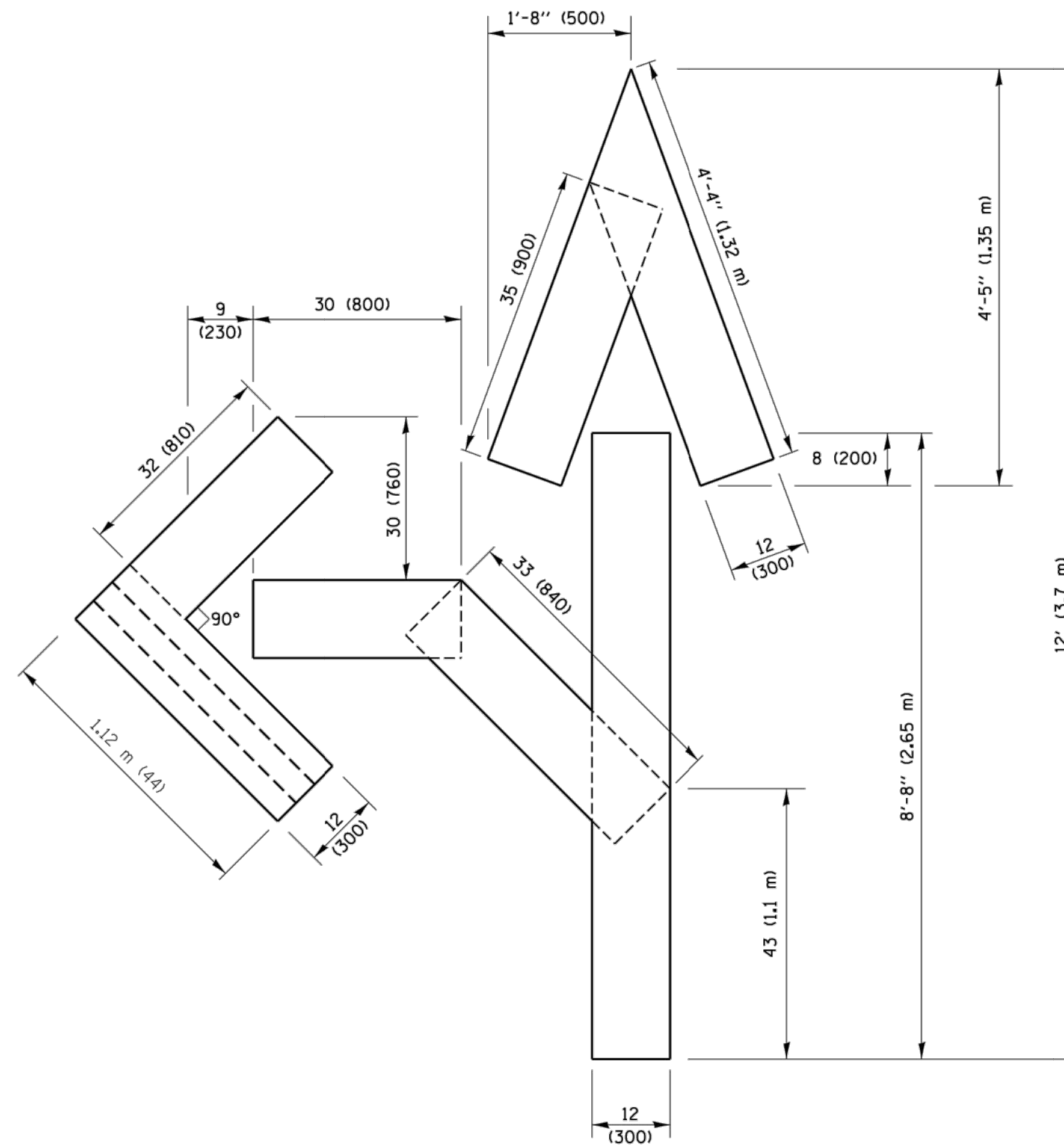

QUANTITY
 4 (100) LINE = 82.5 ft. (25.1 m)
 27.5 sq. ft. (2.53 sq. m)

NOTE:

ALL QUANTITIES OF PLACEMENT ARE REPRESENTED IN LINEAR FEET OF 4" LINES TO MATCH THE 4" TEMPORARY TAPE PAY ITEM AND REPRESENTS THE TOTAL QUANTITY OF 4" TAPE REQUIRED.

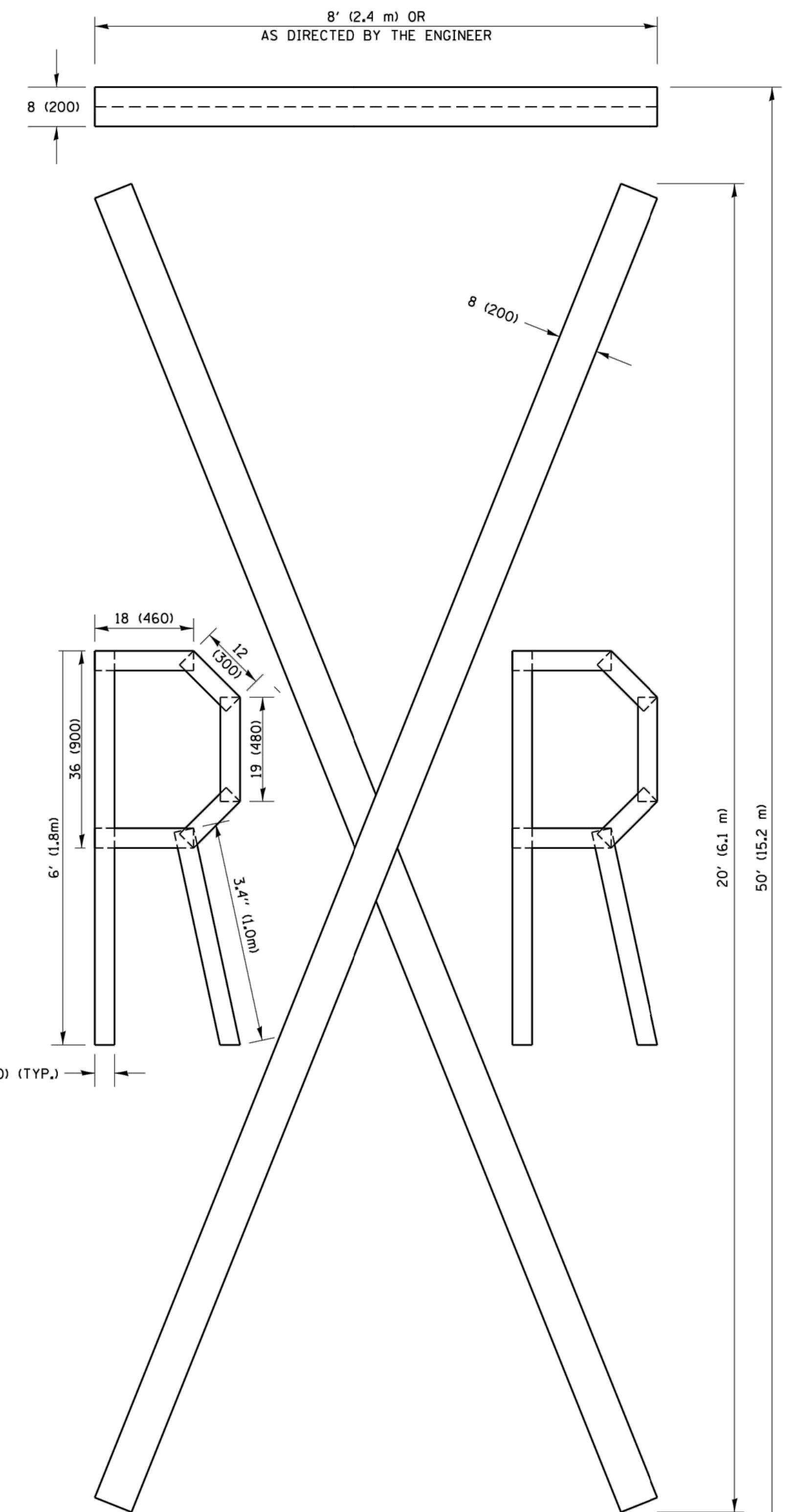

QUANTITY
 4 (100) LINE = 225.9 ft. (68.9 m)
 75.3 sq. ft. (6.99 sq. m)

All dimensions are in inches (millimeters) unless otherwise shown.

FILE NAME =	USER NAME = footemj	DESIGNED -	REVISED - T. RAMMACHER 03-02-98	STATE OF ILLINOIS DEPARTMENT OF TRANSPORTATION	SHORT TERM PAVEMENT MARKING LETTERS AND SYMBOLS		F.A.U. RTE.	SECTION	COUNTY	TOTAL SHEETS	SHEET NO.	
pwt\l\084EBIDINTEG\Illinois.gov\PWIDOT\Documents\DOT Offices\District 1\Projects\Dist 1\CADData\CADsheets\tc16.dgn		DRAWN -	REVISED - E. GOMEZ 08-28-00		SCALE: NONE	SHEET NO. 1 OF 1 SHEETS	STA.	1487	18-00113-00-RS	DUPAGE	19	18
		CHECKED -	REVISED - E. GOMEZ 08-28-00					TC-16		CONTRACT NO.	61E92	
		DATE - 09-18-94	REVISED - A. SCHUETZE 09-15-16					FED. ROAD DIST. NO. 1 ILLINOIS FED. AID PROJECT				

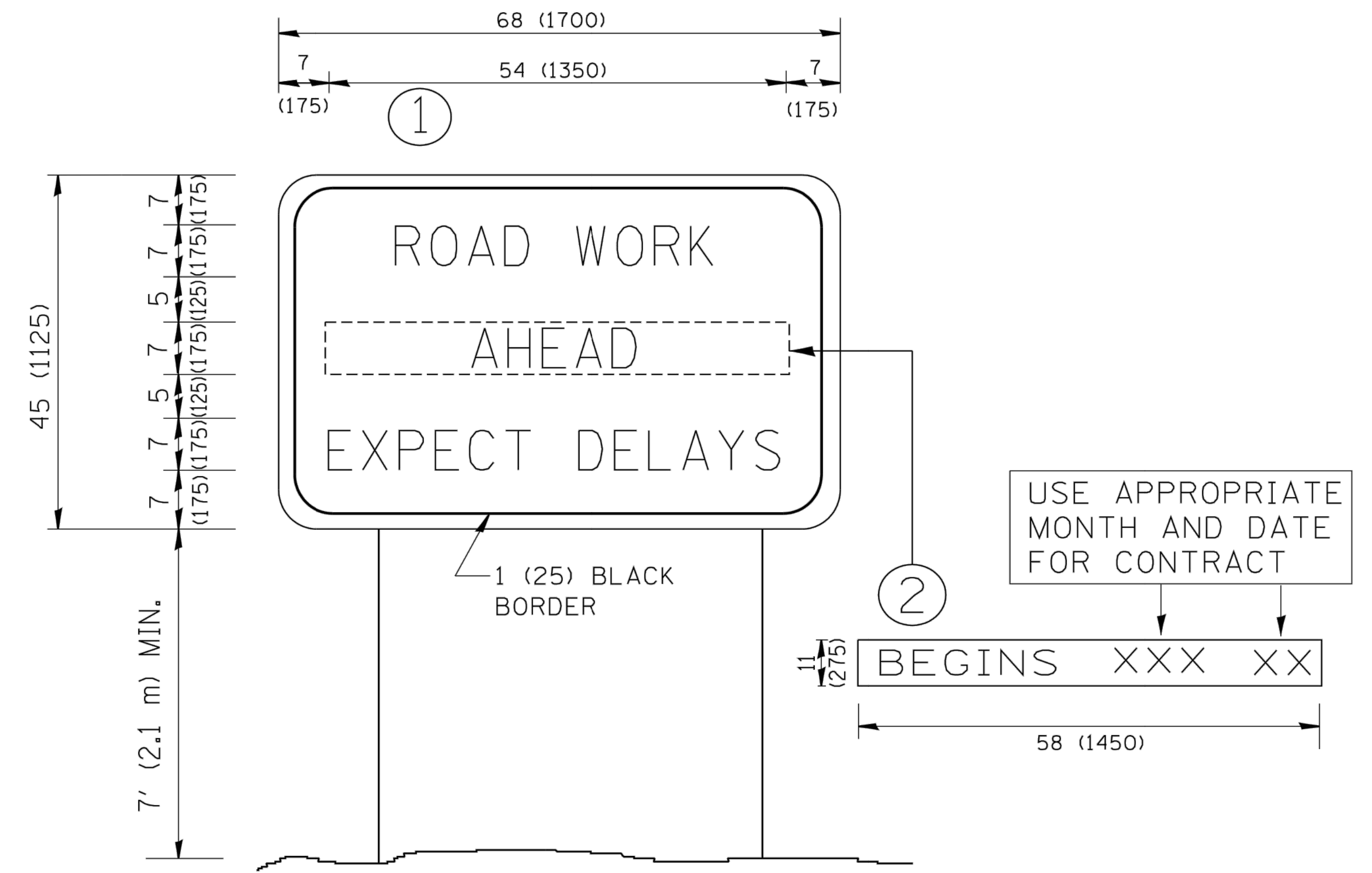

NOTES:

1. USE BLACK LETTERING ON ORANGE BACKGROUND.
2. ERECT SIGNS IN ADVANCE OF THE LOCATION FOR THE "ROAD CONSTRUCTION AHEAD" SIGN AT LOCATIONS AS DIRECTED BY THE ENGINEER.
3. ERECT SIGN ① WITH INSTALLED PANEL ② ONE WEEK PRIOR TO THE START OF CONSTRUCTION.
4. REMOVE PANEL ② SOON AFTER THE START OF CONSTRUCTION.
5. SEE SPECIAL PROVISION FOR "TEMPORARY INFORMATION SIGNING" FOR ADDITIONAL INFORMATION.
6. ONE SIGN ASSEMBLY EQUALS 25.70 SQ. FT. (2.3 SQ. M.)
7. SHALL BE PAID FOR AS TEMPORARY INFORMATION SIGNING.

ALL DIMENSIONS ARE IN INCHES (MILLIMETERS) UNLESS OTHERWISE SHOWN.

FILE NAME = W:\diststd\22x34\tc22.dgn	USER NAME = geglianobt	DESIGNED -	REVISED - R. MIRS 09-15-97	STATE OF ILLINOIS DEPARTMENT OF TRANSPORTATION	ARTERIAL ROAD INFORMATION SIGN			F.A.U. RTE. 1487	SECTION 18-00113-00-RS	COUNTY	TOTAL SHEETS 19	SHEET NO. 19
	PLOT SCALE = 50.000' / IN.	DRAWN -	REVISED - R. MIRS 12-11-97		SCALE: NONE	SHEET NO. 1 OF 1 SHEETS	STA.	TO STA.	TC-22	CONTRACT NO.	61E92	
	PLOT DATE = 1/4/2008	CHECKED -	REVISED - T. RAMMACHER 02-02-99		FED. ROAD DIST. NO. 1 ILLINOIS FED. AID PROJECT							
		DATE -	REVISED - C. JUCIUS 01-31-07									