

Bench Marks: #1 Chiseled "X" in west face of concrete walk, 11.04' southwest of northwest corner of concrete foundation for tavern. Sta. 108+50, 85' RT. EL. 959.70

#2 Chiseled "X" at southeast corner of transformer pad. Sta. 114+35, 75' LT. EL. 957.37

Existing Structure: 24-inch diameter reinforced concrete pipe at downstream end that increases to 42-inch diameter pipe at upstream end. The total length is approximately 38'-6".

The existing structure shall be removed and replaced with a precast concrete box culvert utilizing staged construction.

No salvage.

STATE OF ILLINOIS
DEPARTMENT OF TRANSPORTATION

ROUTE NO.	SECTION	COUNTY	TOTAL SHEETS	SHEET NO.	SHEET NO. 1
F.A.P. 066	2(B&G)R	McHENRY	66	41	6 SHEETS
FED. ROAD DIST. NO. 7	ILLINOIS	FED. AID PROJECT-			

#62391

STATION 107+00
BUILT BY
STATE OF ILLINOIS
FAP RT 066 SEC 2(B&G)R
FA PROJ.
LOADING HS20
STR. NO. 056-0075
NAME PLATE
See Std. 515001

LOADING HS20-44
Allow 50#/sq. ft. for future wearing surface.
DESIGN SPECIFICATIONS
1996 AASHTO with 1997 thru 2002 Interims

DESIGN STRESSES

FIELD UNITS
f_c = 3,500 psi
f_y = 60,000 psi (reinforcement)

PRECAST UNITS
f_c = 5,000 psi
f_y = 65,000 psi (Welded Wire Fabric)

GENERAL NOTES

1. Reinforcement bars shall conform to the requirements of AASHTO M-31, M-42, or M-53 Grade 60.
2. The Contractor shall divert the water flow from the construction area using a suitable method as approved by the resident engineer prior to implementation. Cost incidental to "Precast Concrete Box Culverts."
3. Temporary concrete barriers shall be provided for Stage Construction. See Standard 704001. Pay item for Temporary Concrete Barriers is included in the Roadway Plans.
4. This box culvert has a fill height of less than 2.0 feet. The precast concrete box culvert shall conform to the requirements of AASHTO M-273.
5. Pay item for Steel Plate Beam Guardrail is included in the Roadway Plans. See Standard 630001.
6. Pay item for Sub Base Granular Material, Topsoil, and Seeding are included in the Roadway Plans.

INDEX OF SHEETS

- 1 General Plan
- 2 Construction Details and Bill of Materials
- 3 Box Culvert End Section Details
- 4 Temporary Concrete Barrier for Stage Construction
- 5 Boring Log 3
- 6 Boring Log 4

GENERAL PLAN
U.S. ROUTE 14
(NORTHWEST HIGHWAY)
OVER LAWRENCE CREEK
BYPASS TO LAWRENCE CREEK
FAP 066 SECTION 2(B&G)R
McHENRY COUNTY
STATION 107+00.00
STRUCTURE NO. 056-0075

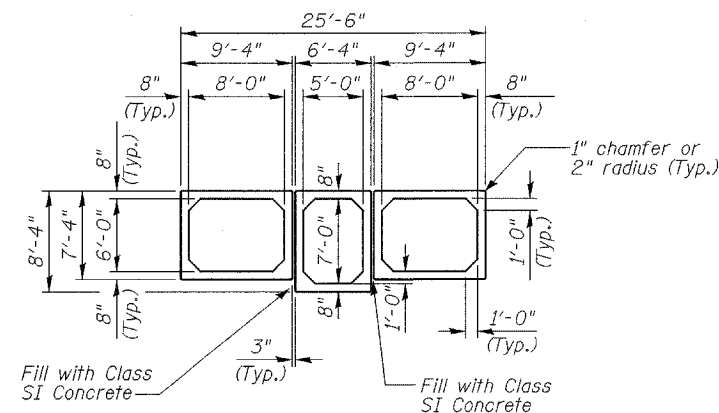
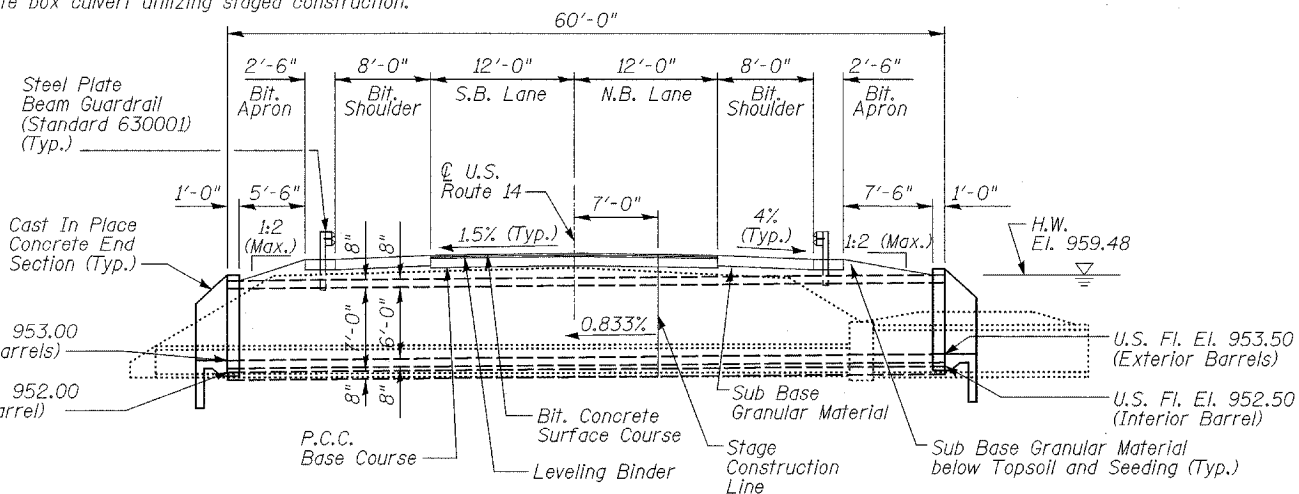

WATERWAY INFORMATION

Drainage Area = 0.26 mi² Low Grade El. 961.92 @ Sta. 106+50

Flood	Freq. Yr.	C.F.S.	Opening Sq. Ft.		Nat. H.W.E.	Head - Ft.			Headwater El.
			Exist.	Prop.		Exist.	Prop.	Exist.	
Design	10	126	4 ft ²	60.89	956.59	3.27	0.00	959.86	956.40
Base	50	169	4 ft ²	90.47	957.57	3.55	0.10	961.12	957.67
Overtopping	100	224	4 ft ²	96.77	957.87	3.39	0.58	961.26	958.45
Max. Calc.	500	295	4 ft ²	117.98	958.88	2.53	1.23	961.41	960.11

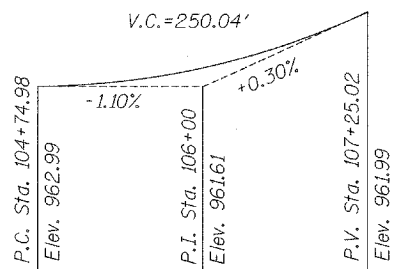
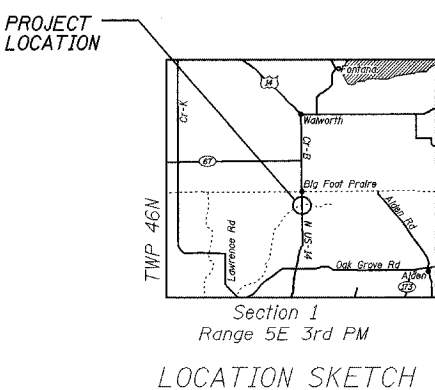
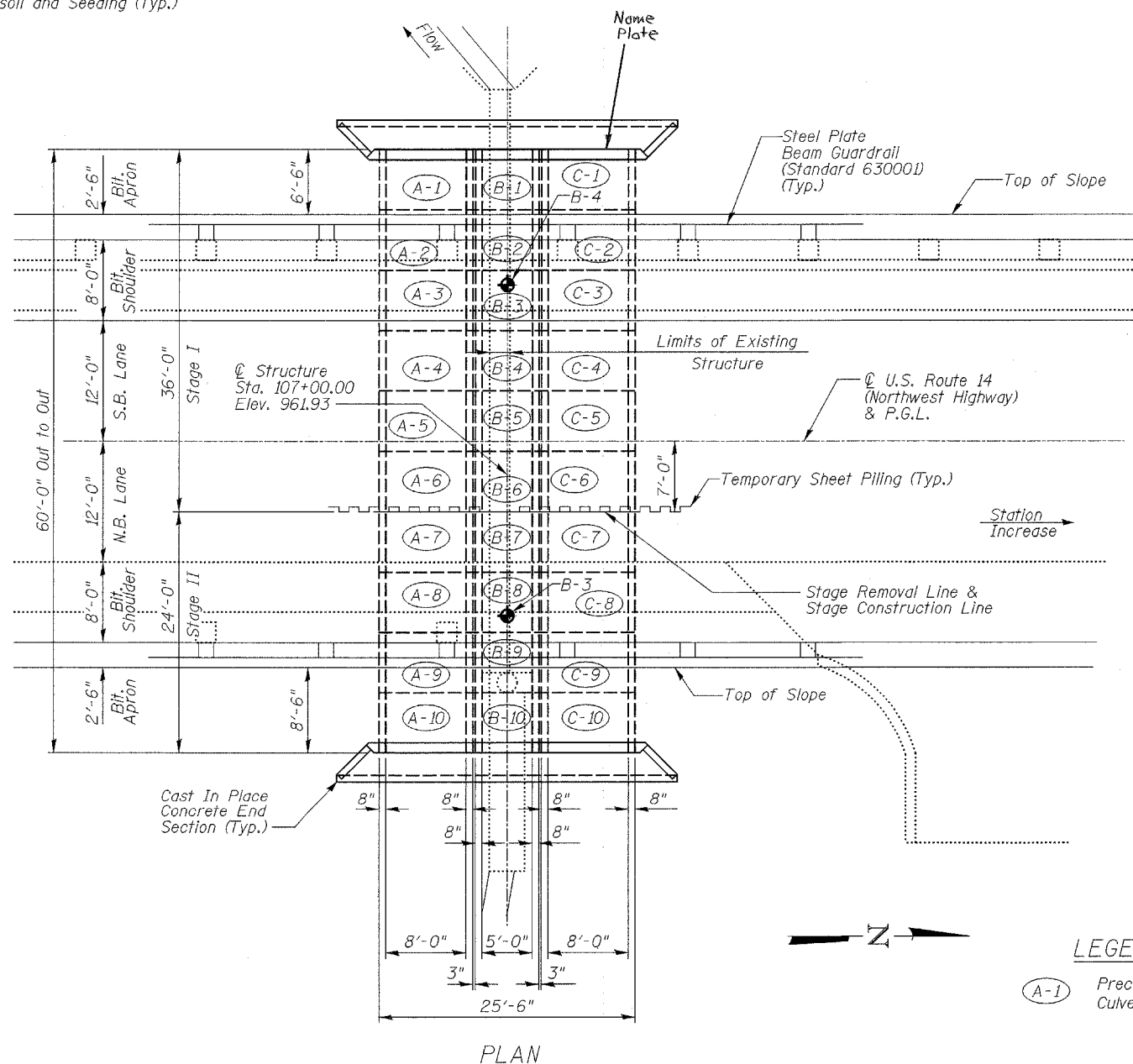

DESIGNED	RFS	20
CHECKED	LLP	ENGINEER OF BRIDGE DESIGN
DRAWN	JPG	PASSED
CHECKED	RFS	ENGINEER OF BRIDGES AND STRUCTURES

LEGEND
A-1 Precast Concrete Box Culvert Cell Number